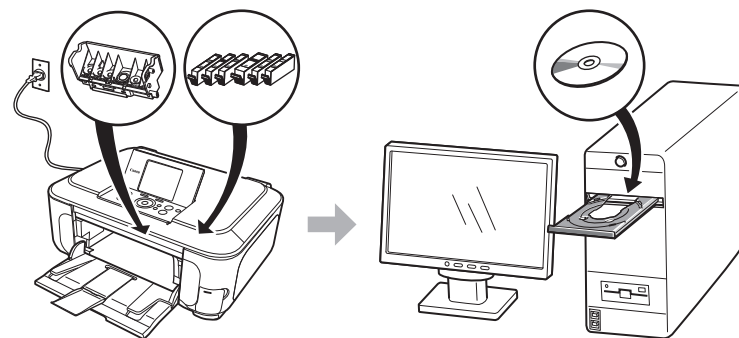

Photo All-In-One

PIXMA MP980 series

Getting Started

=Read Me First=



Make sure to read this manual before using the machine. Please keep it in hand for future reference.



■ Symbols

The following symbols are used to mark important instructions. Observe these instructions.



Instructions that, if ignored, could result in personal injury or material damage.



Instructions that must be observed for safe operation.



Additional explanations.



Descriptions for operations that take some time to complete.

- Microsoft is a registered trademark of Microsoft Corporation.
- Windows is a trademark or registered trademark of Microsoft Corporation in the U.S. and/or other countries.
- Windows Vista is a trademark or registered trademark of Microsoft Corporation in the U.S. and/or other countries.
- Macintosh, Mac, and AirPort are trademarks of Apple Inc., registered in the U.S. and other countries.
- Wi-Fi is a registered trademark of the Wi-Fi Alliance.
The Wi-Fi CERTIFIED logo is a certification mark of the Wi-Fi Alliance.

Model Number: K10327(MP980)

Contents

Unlock the Scanning Unit (Cover)

↳ Turn the Power On



↳ Install the Print Head

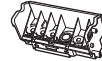

↳ Install the Ink Tanks



↳ Align the Print Head

↳ Confirming the Setup Flow

↳ Setup the Machine and the Computer



↳ Loading Paper

↳ After Installing the Machine

Unlock the Scanning Unit (Cover)

First, check the included items

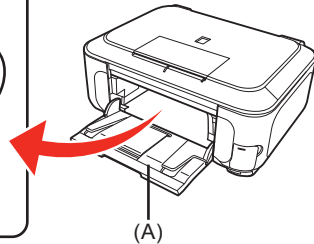
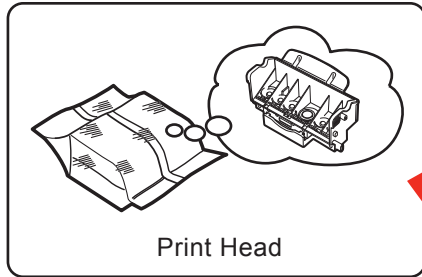

The Print Head is placed inside of the Paper Output Tray (A).

Open the Paper Output Tray with your hands, and take out the Print Head.

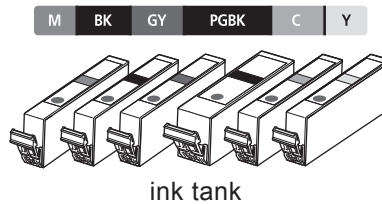
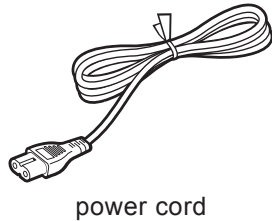

- Manuals
- Setup CD-ROM (containing the drivers, applications and on-screen manuals)
- Warranty
- MP-101 paper (for Automatic Print Head Alignment)



- A USB cable is necessary to connect the machine with your computer.

1

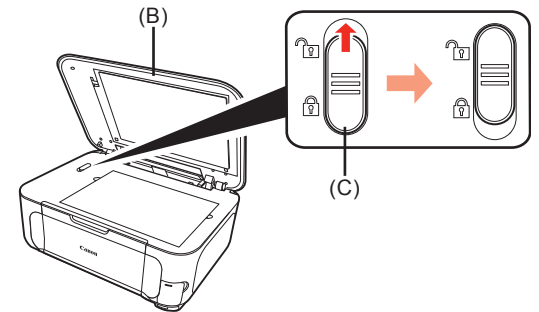

- 1 Open the Document Cover (B).
- 2 Move the Scanner Lock Switch (C) towards the release mark to unlock the Scanning Unit (Cover).
- 3 Close the Document Cover (B).



- Before turning on the machine, remove all the orange tapes and the protective sheets.

2

Turn the Power On

1

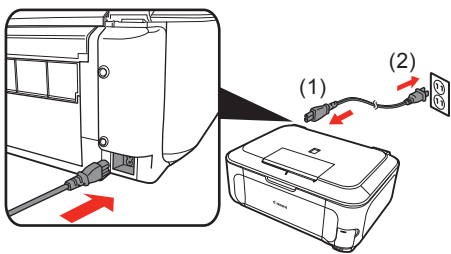

Plug in the power cord on the left side at the back of the machine and connect the other end to the wall outlet.

2

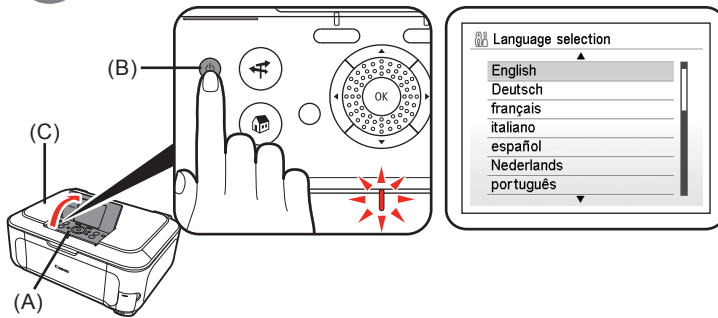

Open the Operation Panel (A), then press the **ON** button (B) to turn on the machine.

3

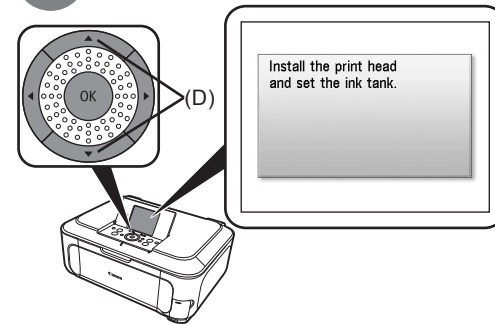

Use the ▲ or ▼ button (D) on the Operation Panel to select the language for the LCD, then press the **OK** button. The standby screen is displayed.



- Make sure that the Document Cover (C) is closed.
- If an unintended language is displayed on the LCD, press the **Back** button on the Operation Panel to return to the **Language selection** screen.



- The machine may make some operating noises. This is normal operation.



- Do NOT connect the USB cable at this stage.

3

Install the Print Head

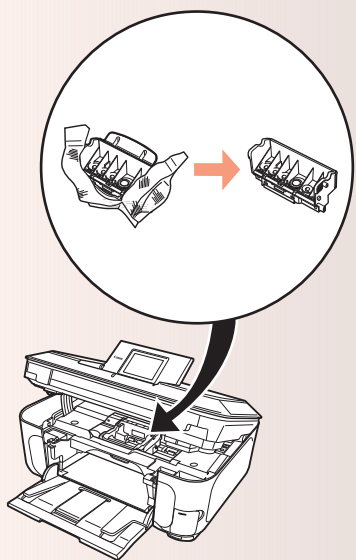

- Do not handle the Print Head roughly such as applying them excessive pressure or dropping them.

1

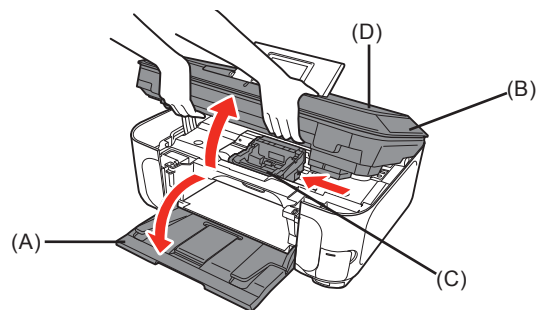

Open the Paper Output Tray (A), then lift the Scanning Unit (Cover) (B) until it locks into place.

The Scanning Unit (Cover) (B) is fixed automatically. The Print Head Holder (C) comes out. (This is where you install the Print Head.)



- For your safety, always grip as illustrated.
- Close the Document Cover (D) and lift it with the Scanning Unit (Cover).



- The Print Head Holder makes a noise as it moves. This is normal operation.

2

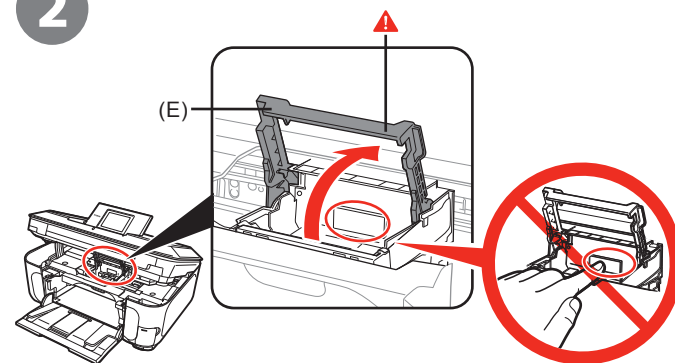

Raise the Print Head Lock Lever (E).



- Firmly raise the Print Head Lock Lever until it stops. (The Print Head Lock Lever may feel heavy.)



- If the Print Head Holder does not move, make sure that the machine is turned on.

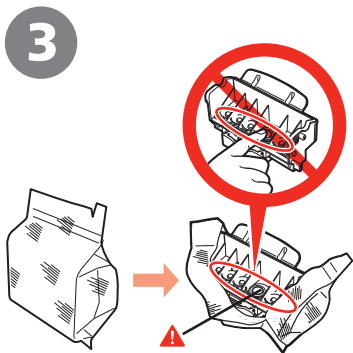

Remove the Print Head from the silver package.

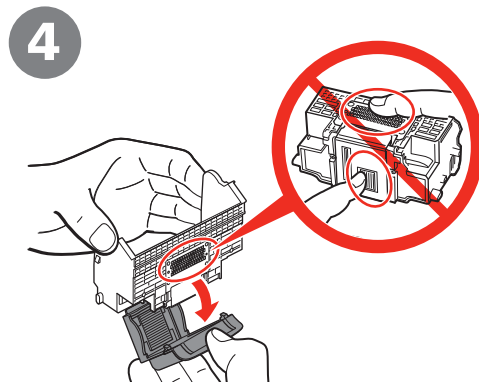

Remove and discard the orange protective cap.



- There may be some transparent or light blue ink on the inside of the bag the Print Head comes in, or the inside of the protective cap - this has no effect on print quality. Be careful not to get ink on yourself when handling these items. Be careful not to stain your hands.

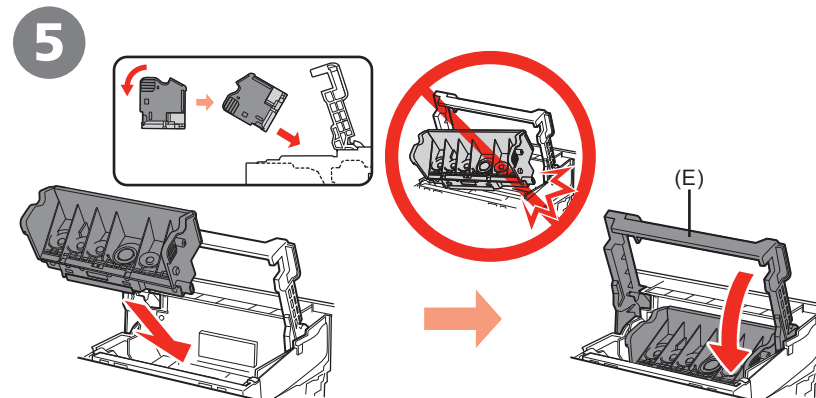

Tilt the Print Head and set it in place. Lower the Print Head Lock Lever (E) completely.



- Do not knock the Print Head against the sides of the Holder.
- Be sure to install it in a well-lit environment.
- Pinch the Print Head Lock Lever firmly and lower it gently.
- Once you have installed the Print Head, do not remove it unnecessarily.

4

Install the Ink Tanks

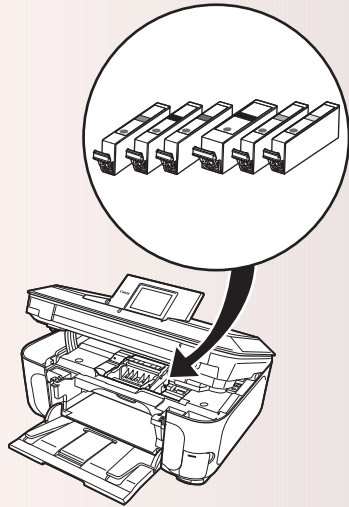

- Do not handle the ink tanks roughly such as applying them excessive pressure or dropping them.



- If the Print Head Holder moves to the right, close and reopen the Scanning Unit (Cover).
- Be sure to use the supplied ink tanks.

1

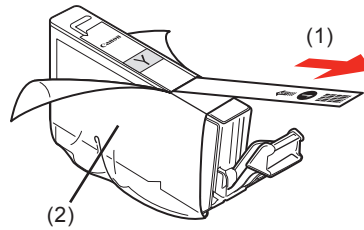

Pull the orange tape (1) in the direction of the arrow to peel off the protective film and remove the film (2) completely.

2

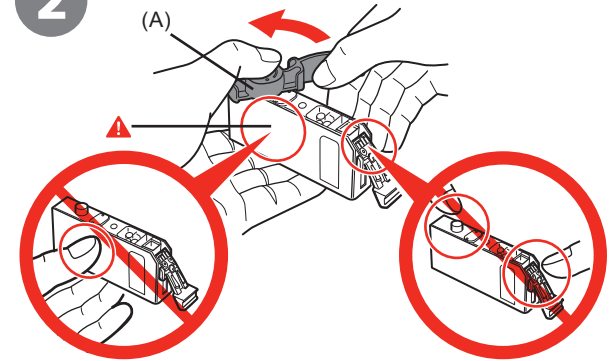

While pressing down with your left thumb, twist off the orange protective cap (A) located on the bottom of the ink tank.



- Do not hold the sides of the ink tank; ink may splash.

3 Install the Ink Tank

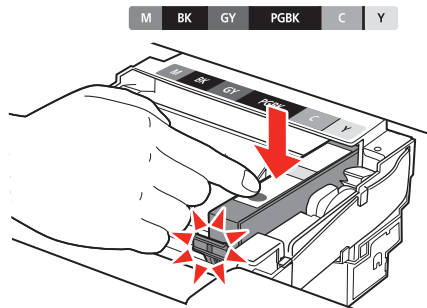

Press the **PUSH** mark on the ink tank until it clicks into place.

Make sure the **Ink** lamp lights red.



- Be sure to install it in a well-lit environment.



- Match the labels when installing.

4

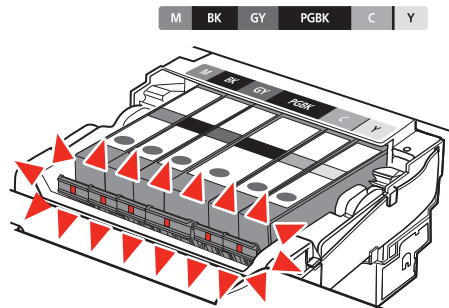

Install all the other ink tanks in the same way.

Install all the ink tanks.



- Once you have installed the ink tanks, do not remove them unnecessarily.



- Make sure all the **Ink** lamp lights red.

5

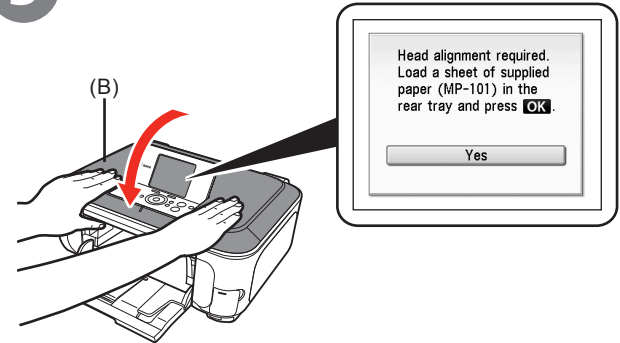

Close the Scanning Unit (Cover) (B).



- Wait until the screen above appears (about 6 minutes) and go to the next step.
- The machine may make some operating noises when preparing to print. This is normal operation.



- For your safety, always grip as illustrated.



- If an error message is displayed on the LCD, make sure that the Print Head and the ink tanks are correctly installed.

5 Align the Print Head

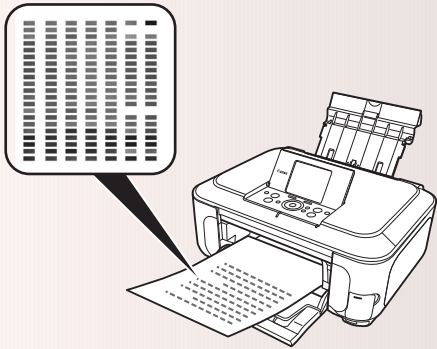

Align the Print Head for better print results.
This takes about 7 minutes.

Use a sheet of supplied speciality paper
(MP-101) for alignment.

1



Open the Paper Support (A) and pull it out.

2

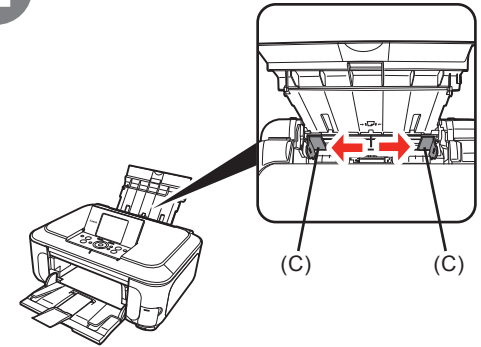

Move the Paper Guides (C) to both edges.



- Make sure that the Output Tray Extension (B) is extended.

3

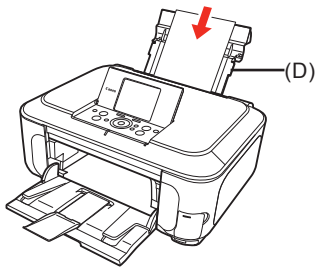

Load a sheet of supplied speciality paper (MP-101) in the Rear Tray (D).



- Be sure to use the supplied speciality paper (MP-101) for Automatic Print Head Alignment.
- MP-101 cannot be fed from the Cassette. Load it in the Rear Tray.
- MP-101 has the front and back sides. Load it with the whiter side facing up.



- For details, refer to "22 Loading Paper" on page 58.

4

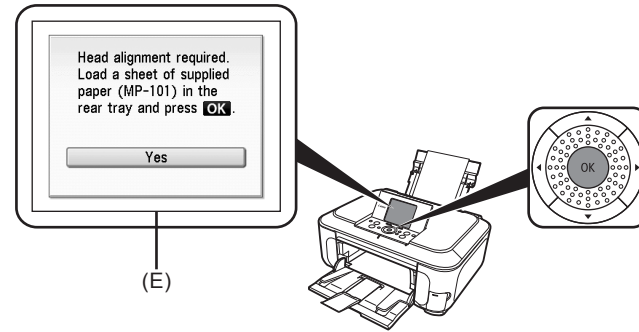

Confirm the message on the LCD (E) and press the **OK** button.



- Print Head Alignment takes about 7 minutes to complete. Wait until the pattern is printed, then go to the next step.



- For details on media sizes and types you can use, refer to "Loading Paper" in the on-screen manual: *Basic Guide*.



5

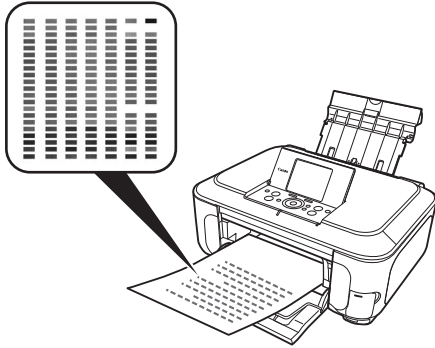

Make sure that a pattern similar to the one shown in the illustration is printed.



- When an error message is displayed on the LCD, refer to "An Error Message Is Displayed on the LCD" in "Troubleshooting" in the on-screen manual: *Advanced Guide*.
- The pattern is printed in black and blue.

6

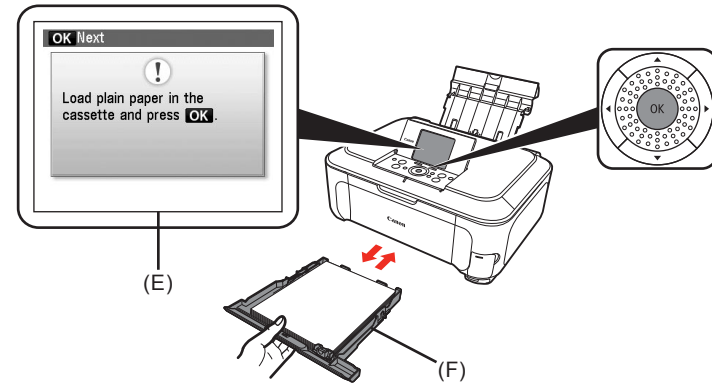

Confirm the message on the LCD (E), then load plain paper into the Cassette (F) and press the **OK** button.

The standby screen is displayed on the LCD.



- For details, refer to "22 Loading Paper" on page 58.
- Close the Paper Output Tray to make it easier to pull out the Cassette.

6

Confirming the Setup Flow

■ Confirming Your Connection Type

Before starting setup, decide on the most suitable connection method for the machine.
This machine can be used over a wireless or wired LAN, as well as via USB connection.

USB

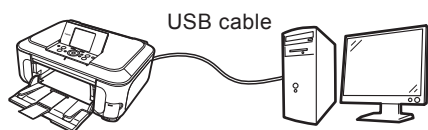

Wired LAN

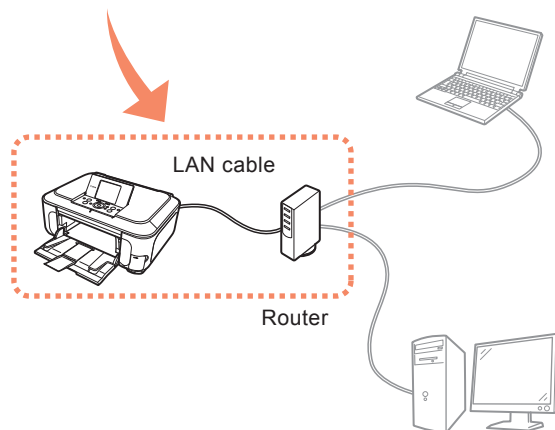

Wireless LAN

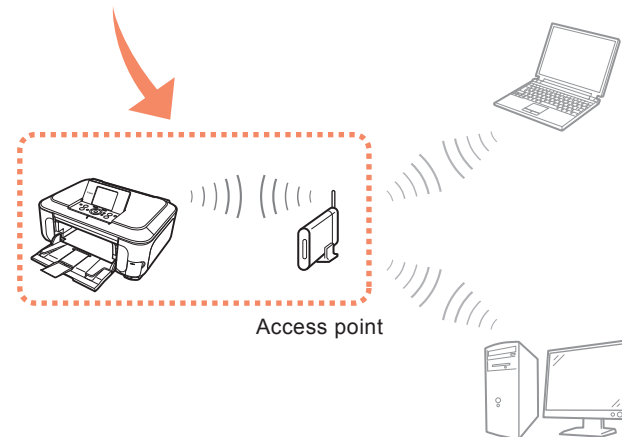

- Before connecting the machine to the network, confirm that configuration of the computer and network devices (router, access point, etc.) is complete, and that the computer can connect to the network. For the procedures to connect a network device to the computer and set them up, refer to the manual of your network device or contact its manufacturer.
- The machine cannot be used over a wired and wireless LAN at the same time.

6

■ Preparation for Setup

To use the machine by connecting it to a computer, software including the drivers needs to be copied (installed) to the computer's hard disk, and setting configured according to the connection method. In addition, configure the machine's LAN settings to connect to the network. Read the following carefully before starting setup.

The screens below are based on Windows Vista operating system Ultimate Edition (hereafter referred to as "Windows Vista") and Mac OS X v.10.5.x.

□ Notes on Setup

- Quit all running applications before installation.
- Log into a user account with the administrator privilege.
- Do not switch user accounts during installation.
- It may be necessary to restart your computer during the installation process. Follow the on-screen instructions and click **OK**, and do not remove the *Setup CD-ROM* during restarting. The installation resumes from where it left off when your computer has been restarted.
- Since Mac OS 9, Mac OS X Classic environments, Mac OS X v.10.3.8 or earlier are not supported.

□ Notes on Network Connection

- Before connecting the machine to the network, confirm that configuration of the computer and network devices (router, access point, etc.) complete, and that the computer can connect to the network.
- For information on how to confirm the settings of the access point, refer to your access point's instruction manual or contact its manufacturer. For example,
 - Disable Stealth (closed network) function
 - Confirm MAC address
 - Disable the access point's IP address

- The configuration, router functions, setup procedures and security functions of the network device vary depending on your environment. For details, refer to your device's instruction manual or contact its manufacturer.
- If the firewall function of your security software is turned on the warning message may appear that Canon software is attempting to access the network. If the warning message appears, set the security software to always allow access.
- In an office setup, consult your network administrator.
- If a screen not specified in the procedure or an error message appears during setup, refer to "5 The following screen is displayed during setup" in the printed manual: *Network Setup Troubleshooting*.

□ Note on Wired LAN Connection

- A router and LAN cable are required to connect the machine to a wired LAN. These must be purchased separately.

□ Notes on Wireless LAN Connection

- Ad-hoc mode is not supported.
- If you connect to a network that is not protected with security measures, there is a risk of disclosing data such as your personal information to a third party.
- The machine may communicate with other access points used in the vicinity.
- The machine supports WPS (Wi-Fi Protected Setup) and WCN (Windows Connect Now) in addition to the conventional wireless LAN settings. As for WCN, "WCN-UFD" that requires a USB flash drive is supported.

■ Setup Flow

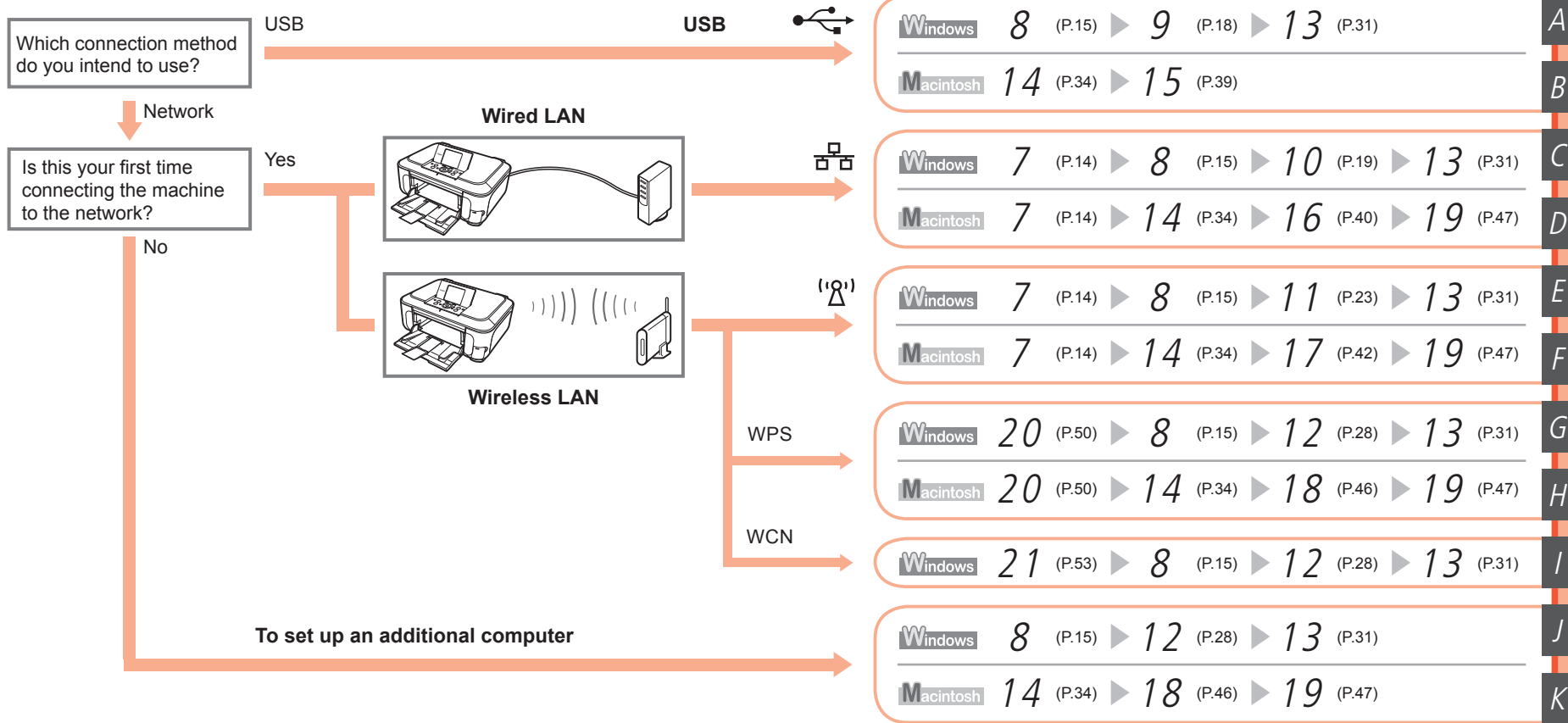

A
B
C
D
E
F
G
H
I
J
K

7

Setup the Machine and the Computer

Machine's LAN Setting

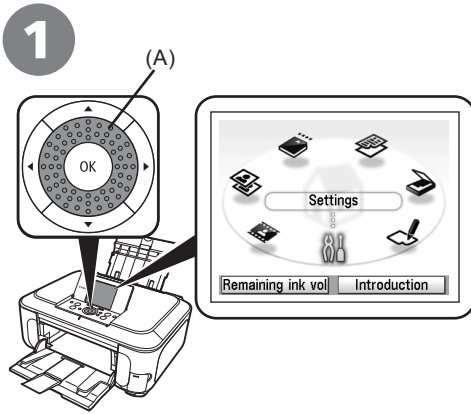

Use the Easy-Scroll Wheel (A) or the ◀ or ▶ button to select **Settings**, then press the **OK** button.

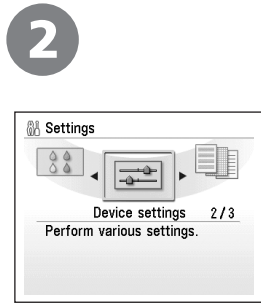

Select **Device settings**, then press the **OK** button.

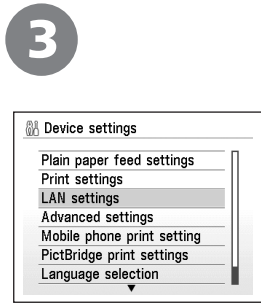

Select **LAN settings**, then press the **OK** button.

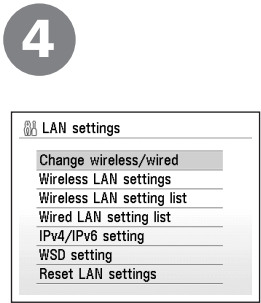

Select **Change wireless/wired**, then press the **OK** button.

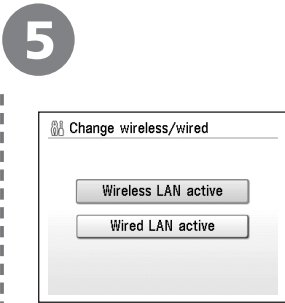

Select either to the connection method, then press the **OK** button.

Next, read "Install the Software" !

- Windows → 8 (P.15)
- Macintosh → 14 (P.34)

C
D
E
F

8

Setup the Machine and the Computer

Install the Software

Windows



If the **Found New Hardware** or **Found New Hardware Wizard** screen appears:

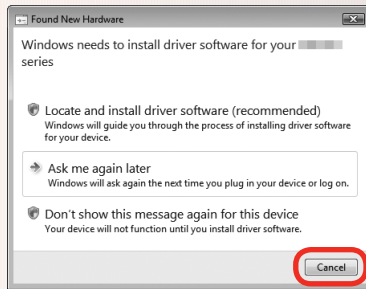

- 1 Remove the USB cable connected to your computer.
The screen may close. In this case, proceed from **1**.
- 2 Click **Cancel** to quit the screen.
- 3 Proceed from **1**.

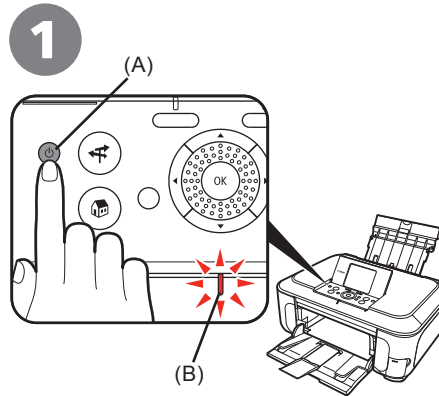

Press the **ON** button (A) to **TURN OFF THE MACHINE**.



- Operating noise continues for about 30 seconds until the machine turns off. Make sure that the **POWER** lamp (B) stops flashing.

2

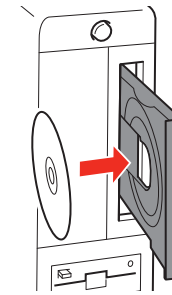

Turn on the computer, then insert the *Setup CD-ROM* into the CD-ROM drive.

The setup program should run automatically.

- Windows Vista → Go to Step **3**.
- Windows XP/2000 → Go to Step **5**.



- If the program does not start automatically, double-click the CD-ROM icon on the computer. When the CD-ROM contents appear, double-click **MSETUP4.EXE**.

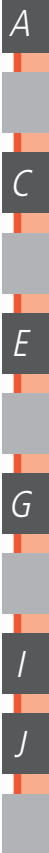

3 Windows Vista

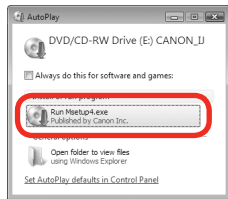

AutoPlay screen appears, click **Run Msetup4.exe**.

4 Windows Vista

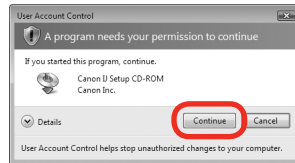

User Account Control screen appears, click **Continue**.

If the same screen reappears in subsequent steps, click **Continue**.

5



Click **Easy Install**.

The drivers, application software, and on-screen manuals are installed automatically.



- If you want to select particular items to install, click **Custom Install** and follow the on-screen instructions to proceed with the installation.



6

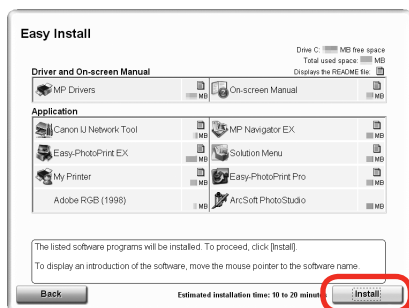

Click **Install**.

Move the cursor over items to display explanations.

7

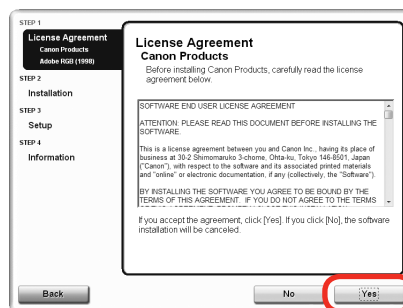

Read the **License Agreement** screen carefully and click **Yes**.

Installation starts.



- Follow any on-screen instructions to install the software.

Go to either of the following procedures according to your connection method!

E	A	USB	→	9	(P.18)
	C	Wired LAN	→	10	(P.19)
	E	Wireless LAN	→	11	(P.23)
	J	Additional Computer	→	12	(P.28)
	G	WPS	...	12	(P.28)
	I	WCN	...	12	(P.28)

A

C

E

G

I

J

9

Setup the Machine and the Computer

USB Connection

Windows



1

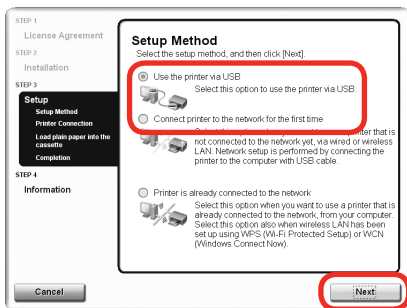

On the **Setup Method** screen, select **Use the printer via USB**, then click **Next**.

2

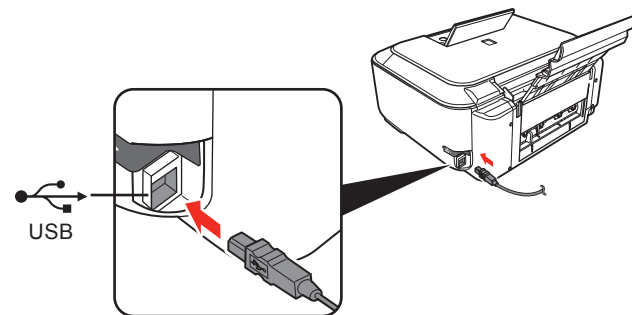
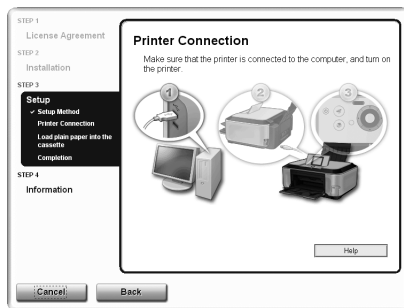

When the **Printer Connection** screen appears, connect the machine to the computer with a USB cable, then turn on the machine.



- When the machine is recognized by the computer, a message appears on the screen.
- If you cannot go to the next procedure after 10 minutes, click **Help** and confirm the message.



- The USB port is located on the right side at the back of the machine.

Next, read "13 Information" on page 31!

10

Setup the Machine and the Computer

First-time Setup for Use over Wired LAN

Windows



1

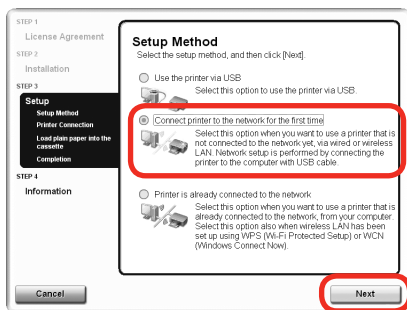

On the **Setup Method** screen, select **Connect printer to the network for the first time**, then click **Next**.

When a confirmation screen for the machine's LAN setting appears, click **OK**.



- Set the machine's LAN setting to **Wired LAN active** beforehand. For details, refer to "7 Machine's LAN Setting" on page 14.

2

Prepare Cables

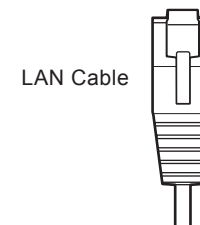
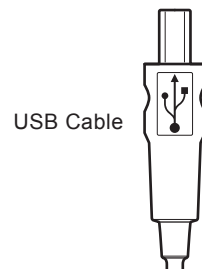

Confirm that USB Cable and LAN Cable are Ready.



3

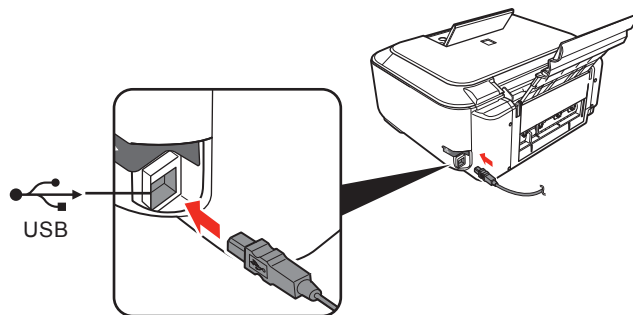
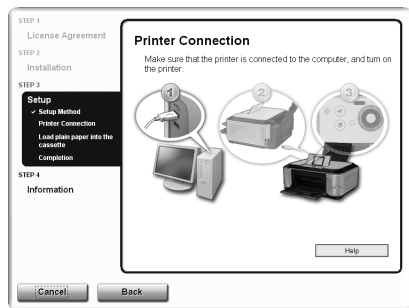

When the **Printer Connection** screen appears, connect the machine to the computer with a USB cable, then turn on the machine.

Set up the machine over a USB connection until the network connection is complete.



- The machine is recognized by the computer, then message appears on the screen.
- If you cannot go to the next procedure after 10 minutes, click **Help** and confirm the message.



- The USB port is located on the right side at the back of the machine.

4

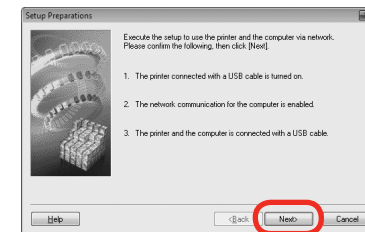

When the **Setup Preparations** dialog box appears, confirm that preparation is complete, then click **Next**.



5

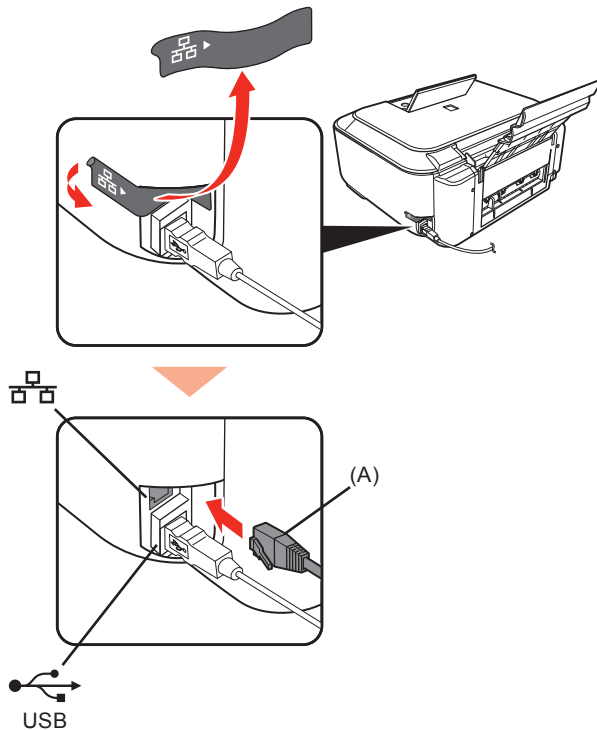

Connect the machine to the network device with a LAN cable (A), then click **Yes**.



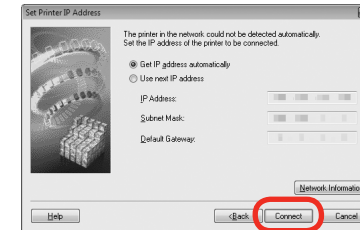

6

Detect the Machine



When the **Set Printer IP Address** screen appears, click **Connect**.

If the machine is detected automatically, the **Set Printer IP Address** screen does not appear. Go to the following procedure.

-  Windows Vista  Go to Step **8**.
-  Windows XP/2000  Go to Step **7**.

- If no connection is established even after **Connect** is clicked, refer to "5.6 The Set Printer IP Address dialog box is displayed during setup" in the printed manual: *Network Setup Troubleshooting*.





7 Windows XP/2000

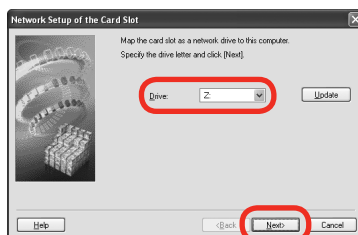

When the **Network Setup of the Card Slot** dialog box appears, specify the drive letter, then click **Next**.



- If the error message appears, refer to "5 The following screen is displayed during setup" in the printed manual: *Network Setup Troubleshooting*.

8

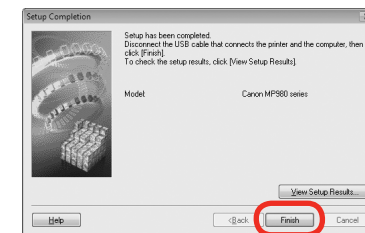
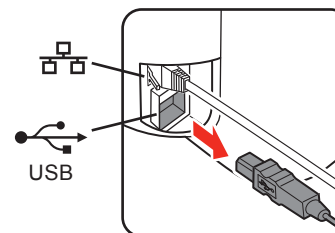

When the **Setup Completion** dialog box appears, remove the USB cable, then click **Finish**.



- To change the port name, click **View Setup Results**, then click **Set Port Name**. For details, refer to "8 Changing the port name" in the printed manual: *Network Setup Troubleshooting*.
- If **Unsafe Removal of Device** is displayed, click **OK**.

Next, read "13 Information" on page 31!



1

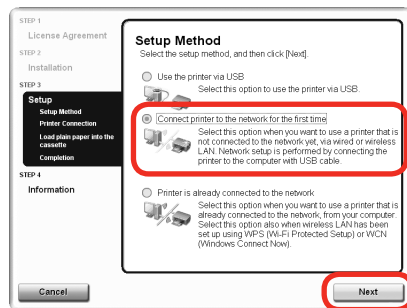

On the **Setup Method** screen, select **Connect printer to the network for the first time**, then click **Next**.

When a confirmation screen for the machine's LAN setting appears, click **OK**.



- Set the machine's LAN setting to **Wireless LAN active** beforehand. For details, refer to "7 Machine's LAN Setting" on page 14.

2

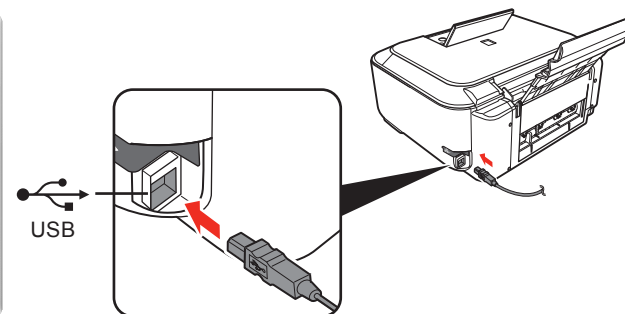
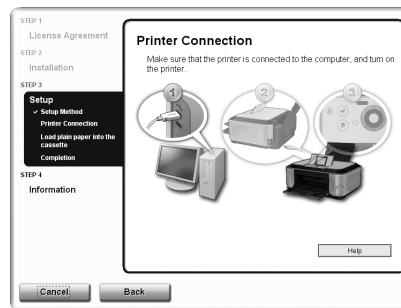

When the **Printer Connection** screen appears, connect the machine to the computer with a USB cable, then turn on the machine.

Set up the machine over a USB connection until the network connection is complete.



- When the machine is recognized by the computer, a message appears on the screen.
- If you cannot go to the next procedure after 10 minutes, click **Help** and confirm the message.



- The USB port is located on the right side at the back of the machine.



E

3

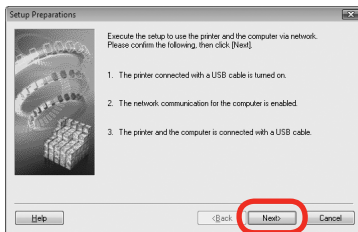

When the **Setup Preparations** dialog box appears, confirm that preparation is complete, then click **Next**.

4

Detect Access Point

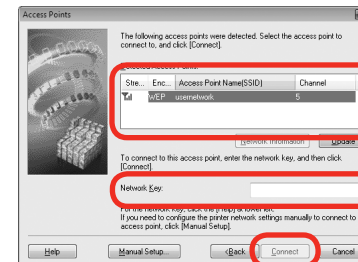

When the **Access Points** screen appears, select an access point to use, then click **Connect**.

When an access point is detected automatically, the **Access Points** screen does not appear. Go to step 5.



- To connect to the access point with **WEP** or **WPA** displayed in the **Encryption** column, enter the network key (WEP key or WPA key) in **Network Key**, then click **Connect**. For details on network keys, refer to "3.1 About Network Key (Windows)/ Network Password (Macintosh)" in the printed manual: *Network Setup Troubleshooting*.



- If you want to select an access point manually, or if the target access point is not displayed in the list, or if an error message appears, refer to "5 The following screen is displayed during setup" in the printed manual: *Network Setup Troubleshooting*.



5 Detect the Machine

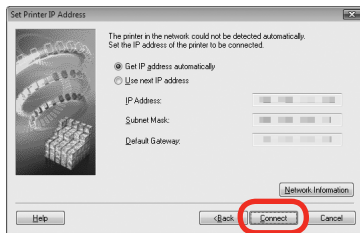

When the **Set Printer IP Address** screen appears, click **Connect**.

If the machine is detected automatically, the **Set Printer IP Address** screen does not appear. Go to the following procedure.

- Windows Vista → Go to Step 7.
- Windows XP/2000 → Go to Step 6.



- If no connection is established even after **Connect** is clicked, refer to "5.6 The Set Printer IP Address dialog box is displayed during setup" in the printed manual: *Network Setup Troubleshooting*.

6 Windows XP/2000

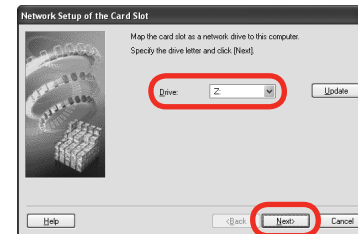

When the **Network Setup of the Card Slot** dialog box appears, specify the drive letter, then click **Next**.



- If the error message appears, refer to "5 The following screen is displayed during setup" in the printed manual: *Network Setup Troubleshooting*.



E

7

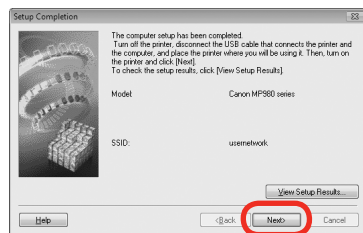
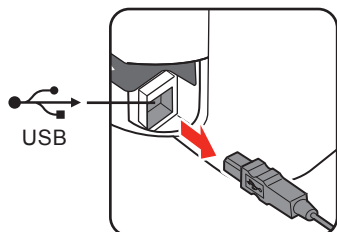

When the **Setup Completion** dialog box appears, remove the USB cable, then click **Next**.



- To change the port name, click **View Setup Results**, then click **Set Port Name**. For details, refer to "8 Changing the port name" in the printed manual: *Network Setup Troubleshooting*.
- If **Unsafe Removal of Device** is displayed, click **OK**.

8

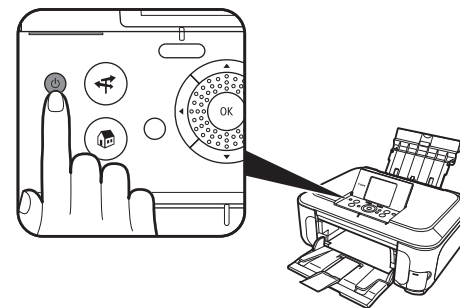

Turn off the machine, then place the machine in the location where you will use it, and turn on it.



9

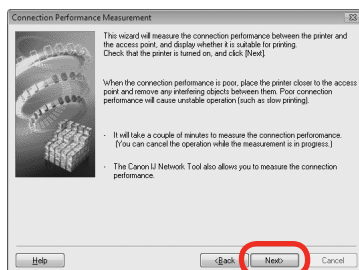

On the **Connection Performance Measurement** screen, click **Next**.

Measuring of the communication status starts, and the results are displayed.



- Measuring takes a few minutes. You can cancel measuring by clicking **Cancel**. You also examine the detailed status of the communication link after setup by using the Canon IJ Network Tool. For details, refer to the on-screen manual: *Advanced Guide*.

10

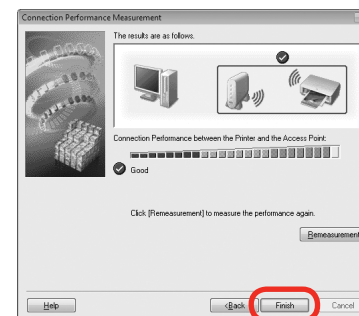

Confirm the measurement results, then click **Finish**.

Ensure that  is displayed in Connection performance between the printer and the access point.



- If any symbol other than  is displayed, refer to displayed comments and Help for improving the status of communication link.
- To check whether the new location is better, click **Remesurement**. Measurement of the communication status is performed again.
- When any message on **Overall network performance** appears in the measurement results, rearrange the printer and other network devices following the instructions on the screen.

Next, read "13 Information" on page 31!

12

Setup the Machine and the Computer

Connect the Wired LAN / Wireless LAN



1

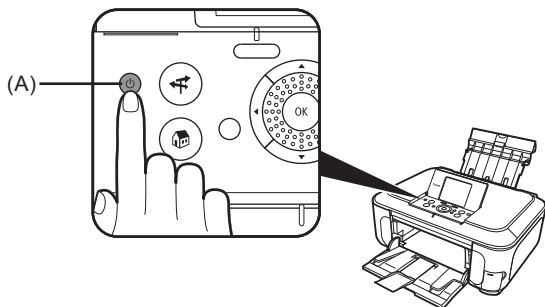

Press the **ON** button (A) to TURN ON THE MACHINE.

2

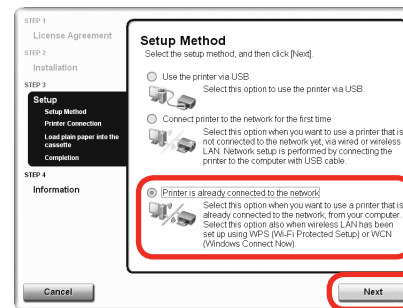

On the **Setup Method** screen, select **Printer is already connected to the network**, then click **Next**.



- Make sure that the computer you are setting up is not connected to the machine with a USB cable.
- For wired LAN connections, confirm that the machine is connected to the network with a LAN cable.



3

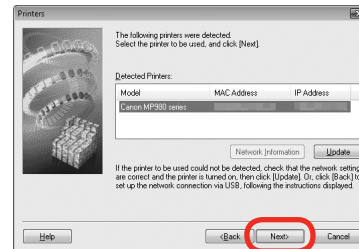

When the **Printers** screen appears, make sure that the machine is selected and click **Next**.

-  Windows Vista  Go to Step 5.
-  Windows XP/2000  Go to Step 4.



- When the machine is not detected, make sure of the following, click **Update**.
 - The machine is turned on.
 - When using wireless LAN : The computer is connected to the access point.
 - When using wired LAN : The machine is connected to the network device with the LAN cable.
- Some programs that switch the network environment depending on your environment will enable a firewall by default. Check the settings of any such software.



G

I

J



4 Windows XP/2000

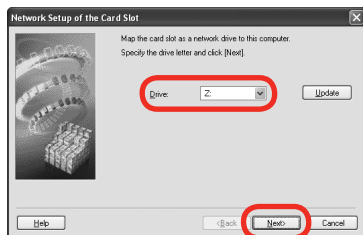

When the **Network Setup of the Card Slot** dialog box appears, specify the drive letter, then click **Next**.



- If the error message appears, refer to "5 The following screen is displayed during setup" in the printed manual: *Network Setup Troubleshooting*.

5

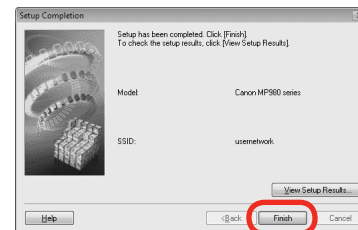

When the **Setup Completion** screen appears, click **Finish**.



- To change the port name, click **View Setup Results**, then click **Set Port Name**. For details, refer to "8 Changing the port name" in the printed manual: *Network Setup Troubleshooting*.

Next, read "13 Information" on page 31!

13

Setup the Machine and the Computer

Information

Windows



1

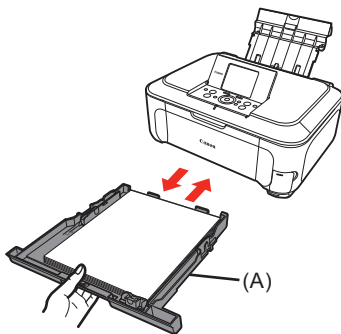
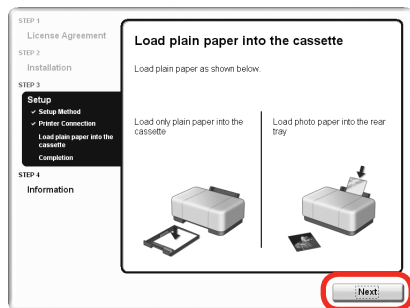

When the **Load plain paper into the cassette** screen appears, load plain paper in the Cassette (A) and click **Next**.



- For details, refer to "22 Loading Paper" on page 58.

2

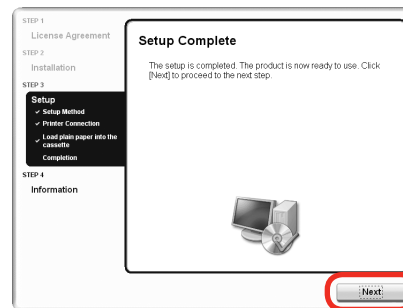

Click **Next**.

It may take a while for the next screen to appear. Click **Next** only once.

A

C

E

G

I

J



3

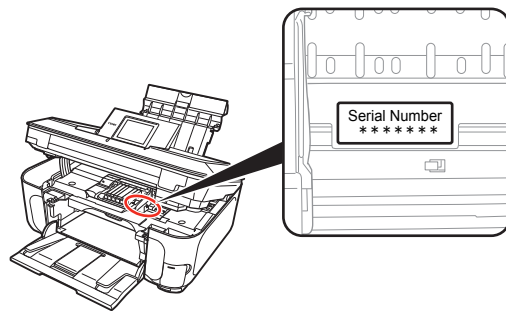
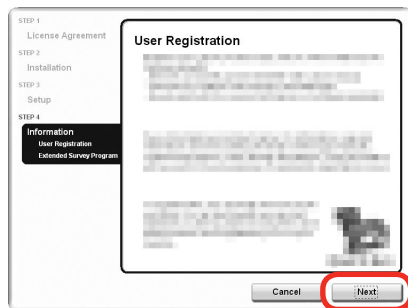

4



Click **Next**.

If connected to the Internet, the user registration page appears. Follow the on-screen instructions to register your product. You will need your product serial number, which is located on the inside of the machine.

When the **Extended Survey Program** screen appears, confirm the message. If you can agree, click **Agree**.

If you click **Do not agree**, the **Extended Survey Program** will not be installed. (This has no effect on the machine's functionality.)



- Internet connection is required. (Connection fees apply.)



- To register later, click **Cancel**. User Registration can be started from the Solution Menu icon. For details, refer to "Solution Menu" on page 62.



5



Click **Exit**.

If **Restart** is displayed, make sure that the **Restart the system now (recommended)** check box is selected, then click **Restart**.

After restarting the computer, remove the *Setup CD-ROM* and keep it in a safe place.

Next, read "22 Loading Paper" on page 58!

A

C

E

G

I

J

14

Setup the Machine and the Computer

Install the Software



1

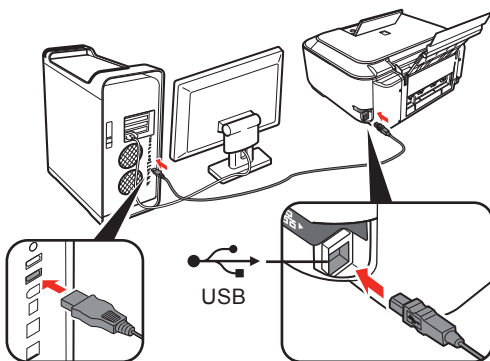

Connect one end of the USB cable to the computer and the other to the machine.

Make sure the machine is turned on.



- The USB port is located on the right side at the back of the machine.
- When using WPS (Wi-Fi Protected Setup) or connecting an additional computer, make sure that the machine is turned on, then go to step 2. It is not necessary to connect the machine to the computer with a USB cable.

2

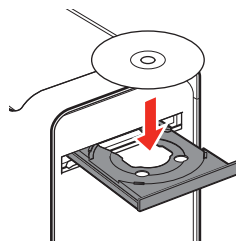

Turn on the computer, then insert the *Setup* CD-ROM into the CD-ROM drive.

3



Double-click the **Setup** icon.

If the CD-ROM folder does not open automatically, double-click the **CANON_IJ** icon on the desktop.



4



Enter your administrator name and password. Click **OK**.

If you do not know your administrator name or password, click **Help**, then follow the on-screen instructions.

5



Click **Easy Install**.

The drivers, application software, and on-screen manuals are installed automatically.



- If you want to select particular items to install, click **Custom Install** and follow the on-screen instructions to proceed with the installation.



B

D

F

H

K

6

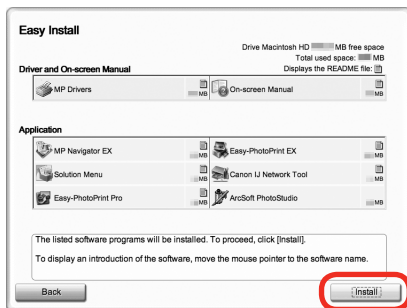

Click **Install**.

Move the cursor over items to display explanations.

7

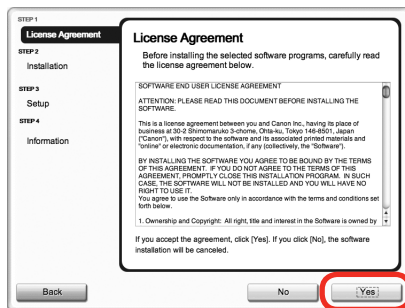

Read the **License Agreement** screen carefully and click **Yes**.

Installation starts.



- Follow any on-screen instructions to install the software.

8

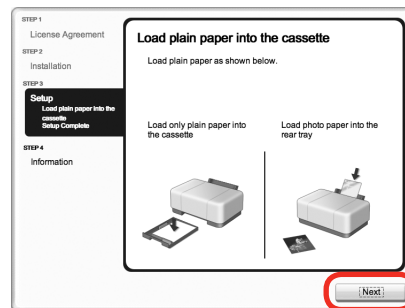

When the **Load plain paper into the cassette** screen appears, load plain paper in the Cassette (A) and click **Next**.

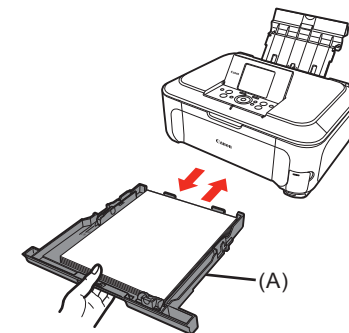

- For details, refer to "22 Loading Paper" on page 58.

B

D

F

H

K



9

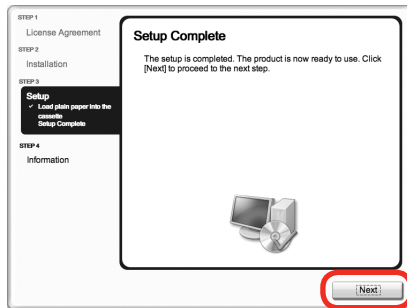

Click **Next**.

10



Click **Next**.

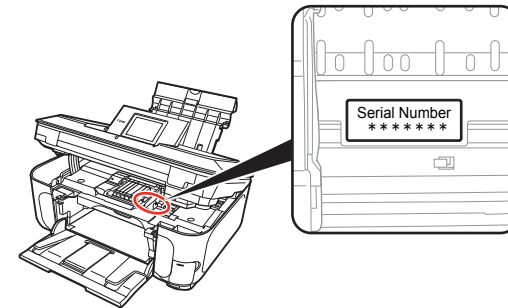

If connected to the Internet, the user registration page appears. Follow the on-screen instructions to register your product. You will need your product serial number, which is located on the inside of the machine.



- Internet connection is required. (Connection fees apply.)



- To register later, click **Cancel**. User Registration can be started from the Solution Menu icon. For details, refer to "Solution Menu" on page 62.



B

D

F

H

K



11



Click **Restart**.

When the computer restarts, Canon IJ Network Tool starts automatically.

Click **Restart** to restart the computer.

After restarting the computer, remove the *Setup CD-ROM* and keep it in a safe place.



- When using Mac OS X v.10.3.9, before using the Operation Panel on the machine to save scanned originals to the computer, it is necessary to select MP Navigator EX as the launch application on **Image Capture** under **Applications**. For details, refer to "Saving Scanned Data to PC Using the Operation Panel of the Machine" in "Scanning" in the on-screen manual: *Advanced Guide*.

Go to either of the following procedures according to your connection method!

E	B	USB	→	15 (P.39)
	D	Wired LAN	→	16 (P.40)
	F	Wireless LAN	→	17 (P.42)
	K	Additional Computer	→	18 (P.46)
	H	WPS	...	18 (P.46)

15

Setup the Machine and the Computer USB Connection

Macintosh



1

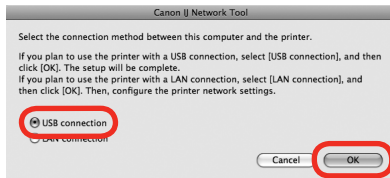

On the **Canon IJ Network Tool** screen, select **USB connection**, then click **OK**.

Next, read "22 Loading Paper" on page 58!

B

16

Setup the Machine and the Computer

First-time Setup for Use over Wired LAN



1

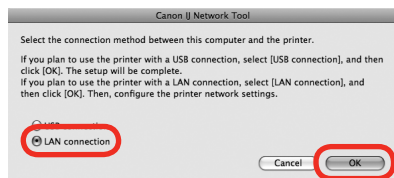

On the **Canon IJ Network Tool** screen, select **LAN connection**, then click **OK**.

2



If the **Setup Preparations** dialog box appears, confirm that preparation is complete, then click **OK**.

3

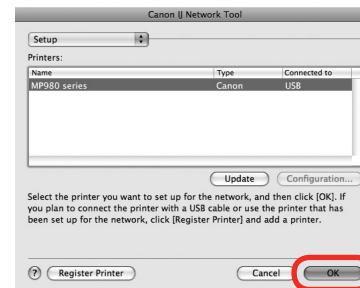

Select **Setup** in the pop-up menu, select **MP980 series** in **Printers**, then click **OK**.

To set up a machine that is not yet connected to a LAN, connect to it by USB.



- Set the machine's LAN setting to **Wired LAN active** beforehand. For details, refer to "7 Machine's LAN Setting" on page 14.



- If no printer is detected, click **OK**. Make sure of the following, then click **Update**.
 - The machine is connected to the computer with a USB cable.
 - The machine is turned on.

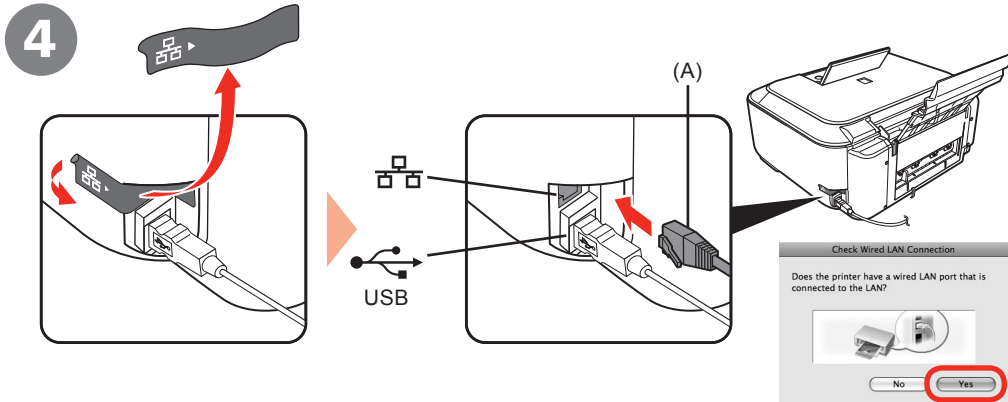

Connect the machine to the network device with a LAN cable (A), then click **Yes**.



- If the **Set Printer IP Address** dialog box appear, refer to "5.6 The Set Printer IP Address dialog box is displayed during setup" in the printed manual: *Network Setup Troubleshooting*.

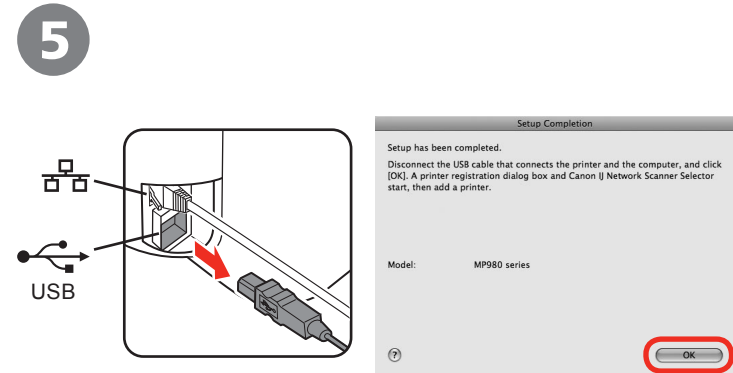

When the **Setup Completion** dialog box appears, remove the USB cable, then click **OK**.

The Printer Setup Utility and Canon IJ Network Scanner Selector will start up.

Next, read "19 Add the Machine" on page 47!

Mac OS X v.10.5.x  Go to Step **2**.

Mac OS X v.10.4.x/v.10.3.9  Go to Step **1**.

17

Setup the Machine and the Computer

First-time Setup for Use over Wireless LAN



1

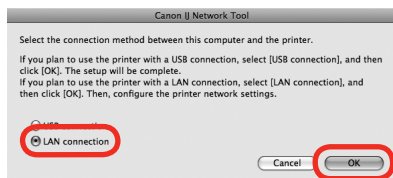

On the **Canon IJ Network Tool** screen, select **LAN connection**, then click **OK**.

2



If the **Setup Preparations** dialog box appears, confirm that preparation is complete, then click **OK**.

3

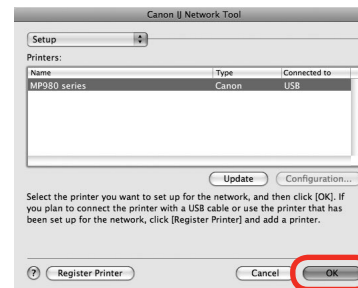

Select **Setup** in the pop-up menu, select **MP980 series** in **Printers**, then click **OK**.



- Set the machine's LAN setting to **Wireless LAN active** beforehand. For details, refer to "7 Machine's LAN Setting" on page 14.



- If no machine is detected, refer to "4.1 The machine is not detected" in the printed manual: *Network Setup Troubleshooting*. Make sure there is no problem, then click **Update**.



4 Detect Access Point

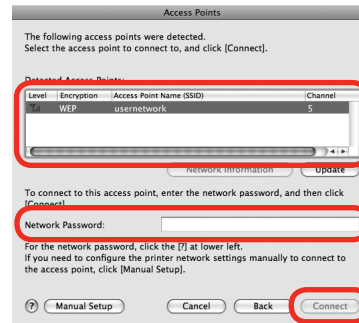

When the **Access Points** screen appears, select an access point to use, then click **Connect**.

When an access point is detected automatically, the **Access Points** screen does not appear. Go to step 5.



- To connect to the access point with **WEP** or **WPA** displayed in the **Encryption** column, enter the network key (WEP key or WPA key) in **Network Password**, then click **Connect**. For details on network keys, refer to "3.1 About Network Key (Windows)/Network Password (Macintosh)" in the printed manual: *Network Setup Troubleshooting*.



- If you want to select an access point manually, or if the target access point is not displayed in the list, or if an error message appears, refer to "5 The following screen is displayed during setup" in the printed manual: *Network Setup Troubleshooting*.



5 Detect the Machine

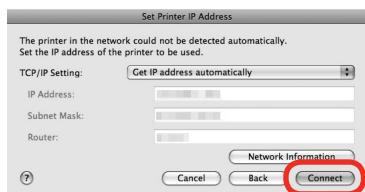

When the **Set Printer IP Address** screen appears, confirm the contents, then click **Connect**.

If the machine is detected automatically, the **Set Printer IP Address** screen does not appear. Go to step 6.



- If no connection is established even after **Connect** is clicked, refer to "5.6 The Set Printer IP Address dialog box is displayed during setup" in the printed manual: *Network Setup Troubleshooting*.

6

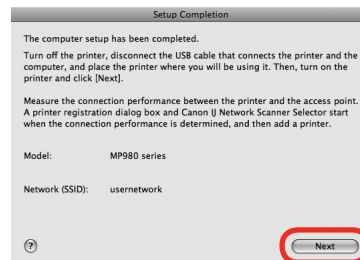
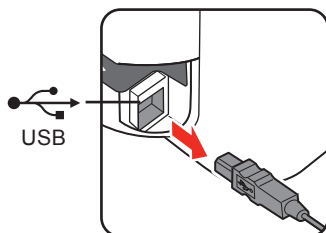

When the **Setup Completion** dialog box appears, remove the USB cable, then click **Next**.

7

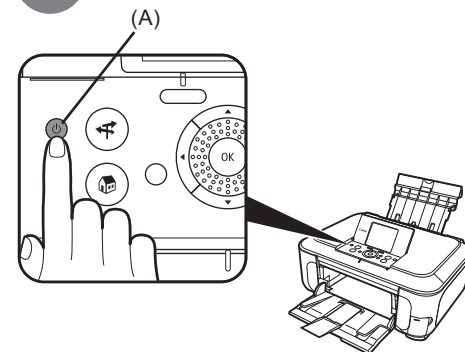

Press the **ON** button (A) TO TURN OFF THE MACHINE, then place the machine in the location where you will use it, and turn on it.



8

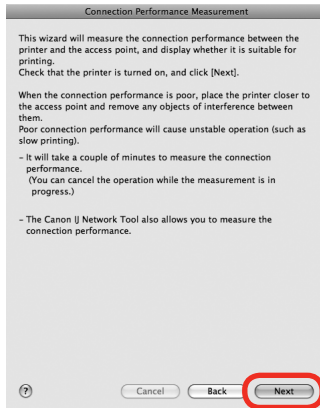

On the **Connection Performance Measurement** dialog box, click **Next**.

Measuring of the communication status starts, and the results are displayed.



- Measuring takes a few minutes. Measuring can be cancelled by clicking **Cancel**. You also examine the detailed status of the communication link after setup by using the Canon IJ Network Tool.

9

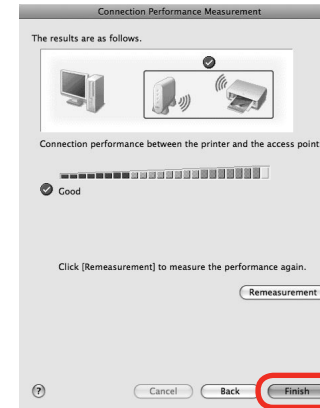

Confirm the measurement results, then click **Finish**.

Ensure that  is displayed in Connection performance between the printer and the access point.

The Printer Setup Utility and Canon IJ Network Scanner Selector will start up.



- If any symbol other than  is displayed, refer to displayed comments and Help for improving the status of communication link.
- To check whether the new location is better, click **Remeasurement**. Measurement of the communication status is performed again.
- When any message on **Overall network performance** appears in the measurement results, rearrange the printer and other network devices following the instructions on the screen.

Next, read "19 Add the Machine" on page 47!

Mac OS X v.10.5.x  Go to Step **2**.

Mac OS X v.10.4.x/v.10.3.9  Go to Step **1**.

18

Setup the Machine and the Computer

Connect the Wired LAN / Wireless LAN

Macintosh



1

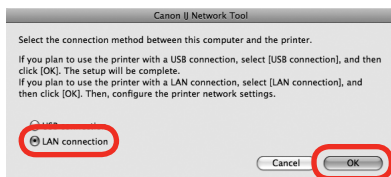

On the **Canon IJ Network Tool** screen, select **LAN connection**, then click **OK**.

2



If the **Setup Preparations** dialog box appears, confirm that preparation is complete, then click **OK**.

3



Select **Setup** in the pop-up menu, then click **Register Printer**.

4

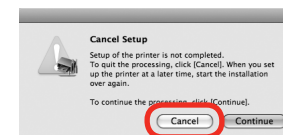

When the **Cancel Setup** screen appears, then click **Cancel**.

The Printer Setup Utility and Canon IJ Network Scanner Selector will start up.



- When the **You have no printers available**. screen appears, click **Cancel**.

Next, read "19 Add the Machine" on page 47!

Mac OS X v.10.5.x  Go to Step **2**.

Mac OS X v.10.4.x/v.10.3.9  Go to Step **1**.

19

Setup the Machine and the Computer

Add the Machine

Macintosh



1 Mac OS X v.10.4.x/v.10.3.9

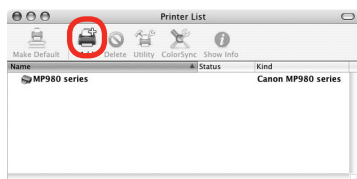

When the **Printer List** screen appears, click **Add**.

- Mac OS X v.10.4.x → Go to Step 2.
- Mac OS X v.10.3.9 → Go to Step 3.

2 Mac OS X v.10.5.x/v.10.4.x

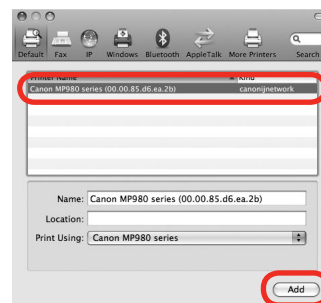

Wait for a while, then select **Canon MP980 series** and click **Add**.

In Mac OS X v.10.4.x, click **More Printers** in the **Printer Browser** screen.

- Mac OS X v.10.5.x → Go to Step 5.
- Mac OS X v.10.4.x → Go to Step 3.



- The alphanumeric string after **Canon MP980 series** is the machine's MAC address.
- If the machine has not been detected, make sure of the following.
 - The machine is turned on.
 - The firewall function of any security software is turned off.
 - Wired LAN Connection: The machine is connected to the network device with the LAN cable.
 - Wireless LAN Connection: The computer is connected to the access point.
 - The machine is not set to use access control (MAC address filtering).

3 Mac OS X v.10.4.x/v.10.3.9

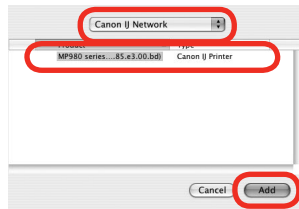

Select **Canon IJ Network** in the pop-up menu, select your machine's name in the list of printers, then click **Add**.



- The alphanumeric string after **Canon MP980 series** is the machine's MAC address.
- If the machine has not been detected, make sure of the following.
 - The machine is turned on.
 - The firewall function of any security software is turned off.
 - Wired LAN Connection: The machine is connected to the network device with the LAN cable.
 - Wireless LAN Connection: The computer is connected to the access point.
 - The machine is not set to use access control (MAC address filtering).

4 Mac OS X v.10.4.x/v.10.3.9



Confirm that your **MP980 series** is added to the list of printers.



5

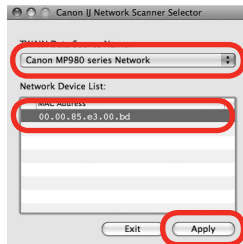

On the **Canon IJ Network Scanner Selector** screen, select **Canon MP980 series Network** in **TWAIN Data Source Name** and the MAC address of the machine in **Network Device List**, then click **Apply** to use the machine as a scanner.

6

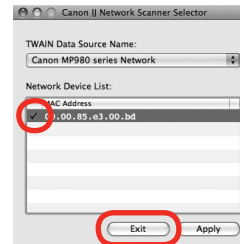

Confirm that a check mark is displayed, then click **Exit** to close the dialog box.

Next, read "22 Loading Paper" on page 58!



- To confirm the machine's MAC address, refer to "Troubleshooting" in the on-screen manual: *Advanced Guide* available via Solution Menu.
- With Mac OS X v.10.5.x, the Card Slot is not available when using the machine over a network.

D

F

H

K

20

Setup the Machine and the Computer

WPS Connection

If your access point supports WPS (Wi-Fi Protected Setup), you can set the wireless LAN security easily.

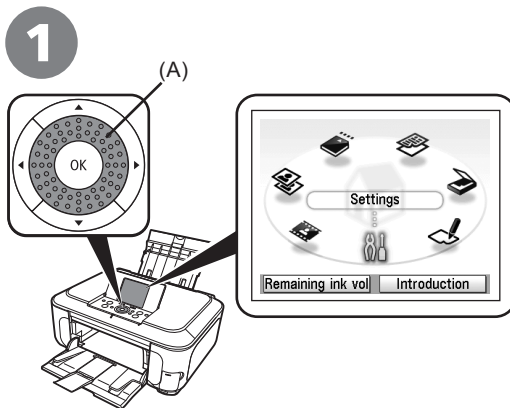

Use the Easy-Scroll Wheel (A) or the ◀ or ▶ button to select **Settings**, then press the **OK** button.

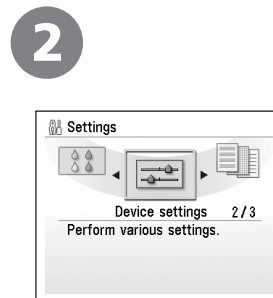

Select **Device settings**, then press the **OK** button.

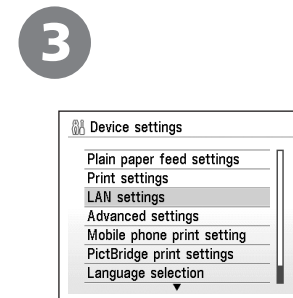

Select **LAN settings**, then press the **OK** button.

G

H

4

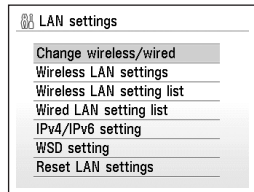

Select **Change wireless/wired**, then press the **OK** button.

5

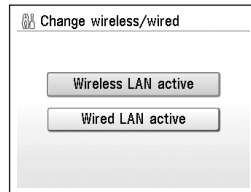

Select **Wireless LAN active**, then press the **OK** button.

6

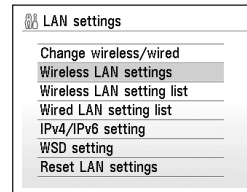

Select **Wireless LAN settings**, then press the **OK** button.

7

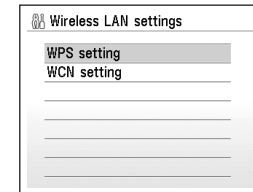

Select **WPS settings**, then press the **OK** button.



8

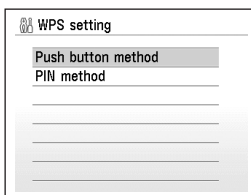

Select **Push button method**, then press the **OK** button.



- To use the PIN code method for setup, select **PIN method** on step 8, then press the **OK** button. Follow the on-screen instructions to operate the machine and access point. When the setup is complete, the completion screen appears then the **LAN settings** screen returns. A timeout error occurs if setup is not completed within 10 minutes. If the timeout error screen appears, refer to "5.12 The Timeout error screen is displayed during WPS setup" in the printed manual: *Network Setup Troubleshooting*.

9

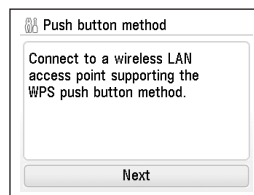

Press the **OK** button.

10

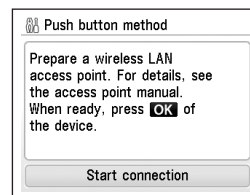

When the access point is ready, press the **OK** button on the machine, then press the **WPS** button on the access point within two minutes.

The completion screen appears on the LCD of the machine, then the **LAN settings** screen returns.



- A timeout error occurs if setup is not completed within two minutes. When the timeout error screen appears, refer to "5.12 The Timeout error screen is displayed during WPS setup" in the printed manual: *Network Setup Troubleshooting*.



- The WPS button may be named differently depending on your access point. For details, refer to the manual of your access point.

Next, read "Install the Software" !

Windows → 8 (P.15)

Macintosh → 14 Step 2 (P.34)

21

Setup the Machine and the Computer

WCN Connection

Windows

You can set the wireless LAN security on the machine easily by using the WCN (Windows Connect Now) function of Windows Vista together with a USB flash drive.



- Canon assumes no responsibility for any damage or loss of stored data regardless of the cause.
- If your USB flash drive cannot be attached to the direct print port of the machine, an extension cord for USB flash drives may be required. Purchase one at an electronics shop.
- Operation may not be guaranteed depending on your USB flash drive.
- USB flash drives with security enabled may not be used.



- The machine supports "WCN-UFD".

1

2

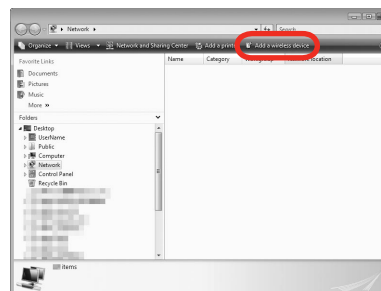

From the Start menu of the Windows side, click **Network**.

The **Network** folder opens.

Click **Add a wireless device** on the menu.

The **Add a wireless device to the Network** screen will be displayed.



3

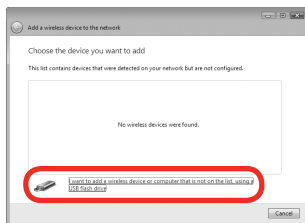

Click **I want to add a wireless device or computer that is not on the list, using a USB flash drive.**

4

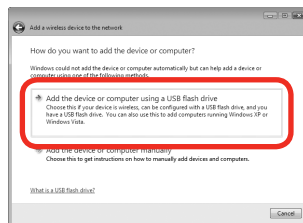

Click **Add the device or computer using a USB flash drive.**

5

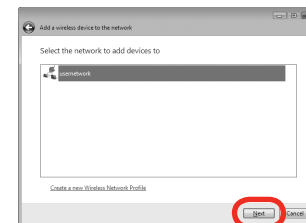

From the list, select the network name (SSID), then click **Next.**



- If the **User Account Control** screen appears, click **Continue**. If the same screen reappears in subsequent steps, click **Continue**.

6

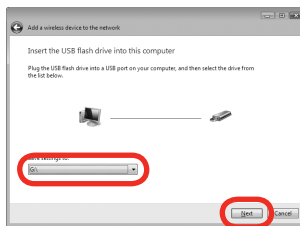

Connect the USB flash drive to the computer, confirm that the drive name is displayed, then click **Next**.

7

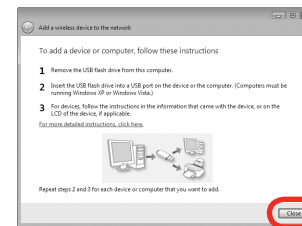

When the above screen appears, remove the USB flash drive from the computer, then click **Close**.



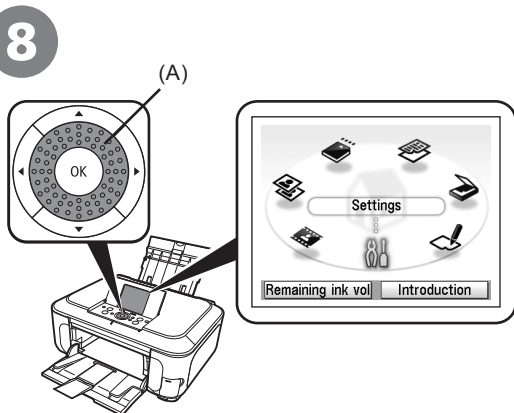

Use the Easy-Scroll Wheel (A) or the ◀ or ▶ button to select **Settings**, then press the **OK** button.

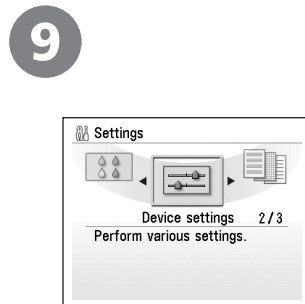

Select **Device settings**, then press the **OK** button.

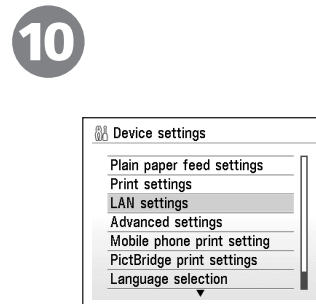

Select **LAN settings**, then press the **OK** button.

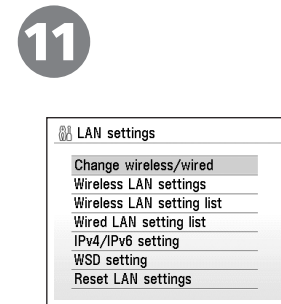

Select **Change wireless/wired**, then press the **OK** button.

12

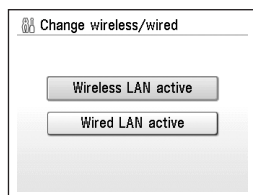

Select **Wireless LAN active**, then press the **OK** button.

13

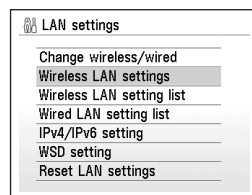

Select **Wireless LAN settings**, then press the **OK** button.

14

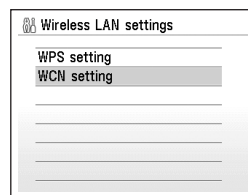

Select **WCN settings**, then press the **OK** button.

15

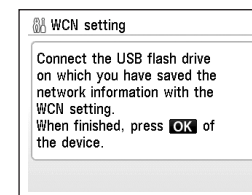

Connect the USB flash drive to the direct print port (USB connector) on the front of the machine, then press the **OK** button.

The completion screen appears on the LCD of the machine, then the **LAN settings** screen returns. Remove the USB flash drive from the machine.

Next, read "8 Install the Software" on page 15!

22

Loading Paper

This section explains how to load paper in the Cassette (A) and the Rear Tray (B).

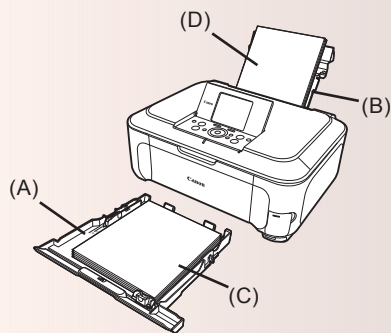

The Cassette (A) supports plain paper (C) only. To print Photo Paper / Hagaki (D), be sure to load it in the Rear Tray (B).

1 Load in the Cassette

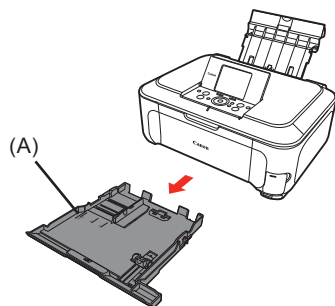

Pull out the Cassette (A).

2

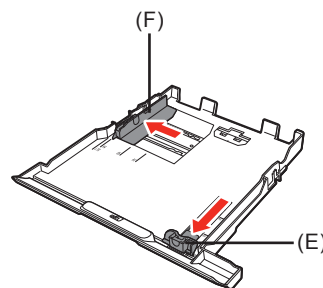

Move the Paper Guides (E) and (F) to both edges.

3

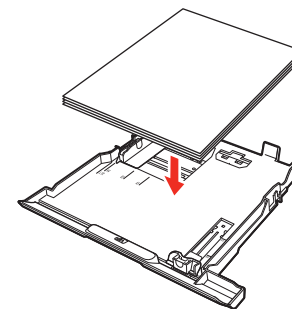

Load paper.



- Load paper with the printing side facing down.

4

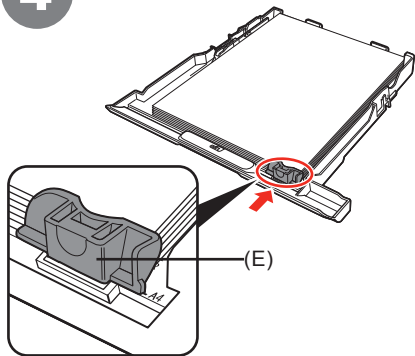

Slide the Paper Guide (E) to align with the mark of paper size.

The Paper Guide (E) will stop when it aligns with the corresponding mark of paper size.



- There may be a little space between the Paper Guide (E) and the paper stack.

5

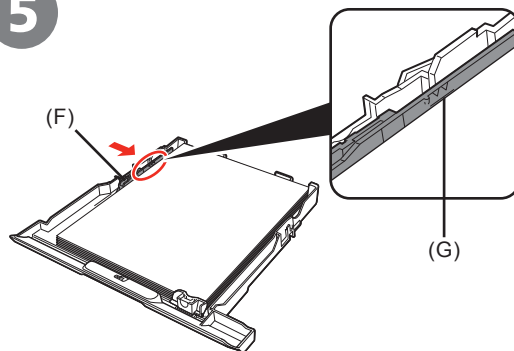

Slide the Paper Guide (F) against left edge of the paper.

Do not exceed the Load Limit Mark (G).



- To print on speciality paper, be sure to load it in the Rear Tray.

6

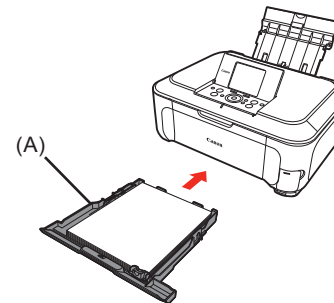

Insert the Cassette (A) into the machine until it clicks into place.



7 Load paper in the Rear Tray

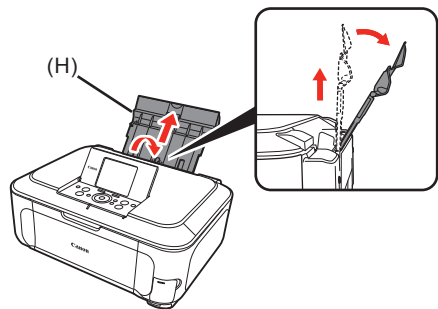

Open the Paper Support (H) and pull it out.

8

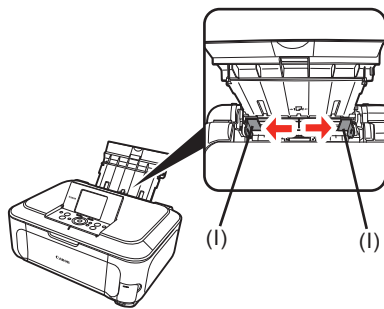

Move the Paper Guides (I) to both edges.

9

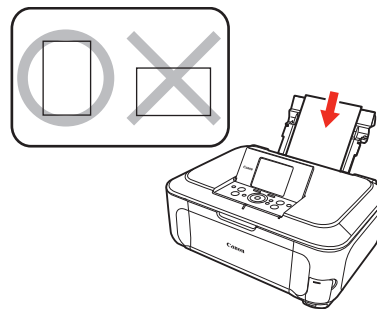

Load paper in the center of the Rear Tray.



- Load paper in portrait orientation with the printing side facing up.

10

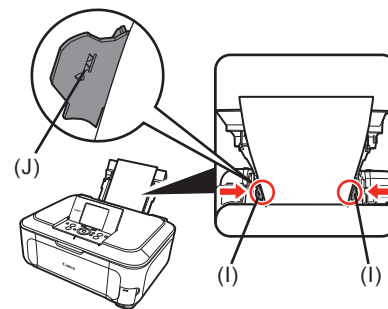

Slide the left and right Paper Guides (I) against both edges of the paper.

Do not exceed the Load Limit Mark (J).



- For details on media sizes and types you can use, refer to "Loading Paper" in the on-screen manual: *Basic Guide*.

Machine installation is now complete!



After Installing the Machine

■ Manuals

Safety Precautions

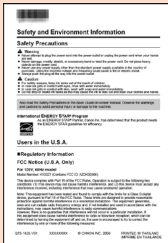

Safety and Environment Information

For proper use, read safety precautions before using the product.

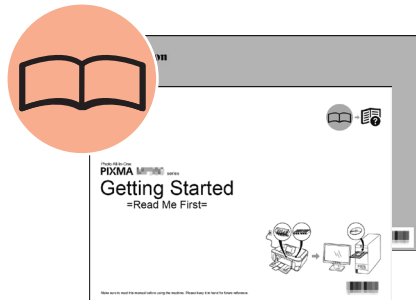

Getting Started (this manual) Network Setup Troubleshooting

Describes how to set up and use your machine. Introduces the machine and its functions, the included manuals and application software.



Basic Guide (on-screen manual)

Describes the basic operations and gives an introduction to other functions available.



Advanced Guide (on-screen manual)

Describes various operating procedures to make full use of the machine. Also includes "Troubleshooting" information for your machine.



■ Solution Menu

Solution Menu is a gateway to functions and information that allow you to make full use of the machine!



Example: Windows Vista



Open various applications and on-screen manuals with a single click.

You can start Solution Menu from the **Solution Menu** icon on the desktop (Windows) or on the Dock (Macintosh).

If you have a problem with machine settings, click the **Change settings or find solutions to problems** icon in Solution Menu to open **My Printer** (Windows only).

*The buttons displayed vary depending on the country or region of purchase.

■ Using Your Machine

This machine allows you to print in various ways using the MP driver and application software installed on the computer. For example, you can print borderless photos, and create your own calendar etc. easily. Also, you can scan documents into a computer, and correct/enhance scanned images.

For detailed operating procedures and functions, refer to the on-screen manuals.

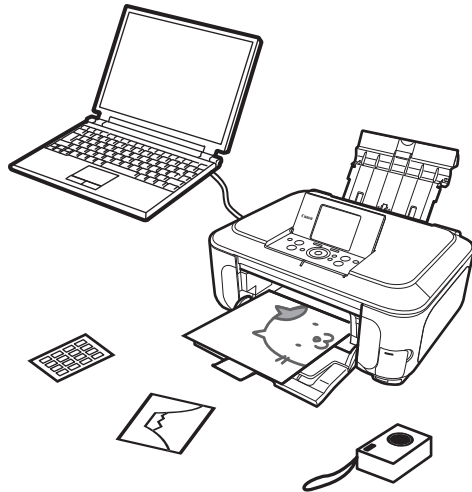

Now let's use the machine!



Print Photos from a Memory Card

Print images saved on a memory card used with digital cameras, etc.

For more information on printing from a memory card, refer to "Printing from a Memory Card" in the on-screen manual: *Basic Guide*.

*Supported Memory Cards (Adapter required for )

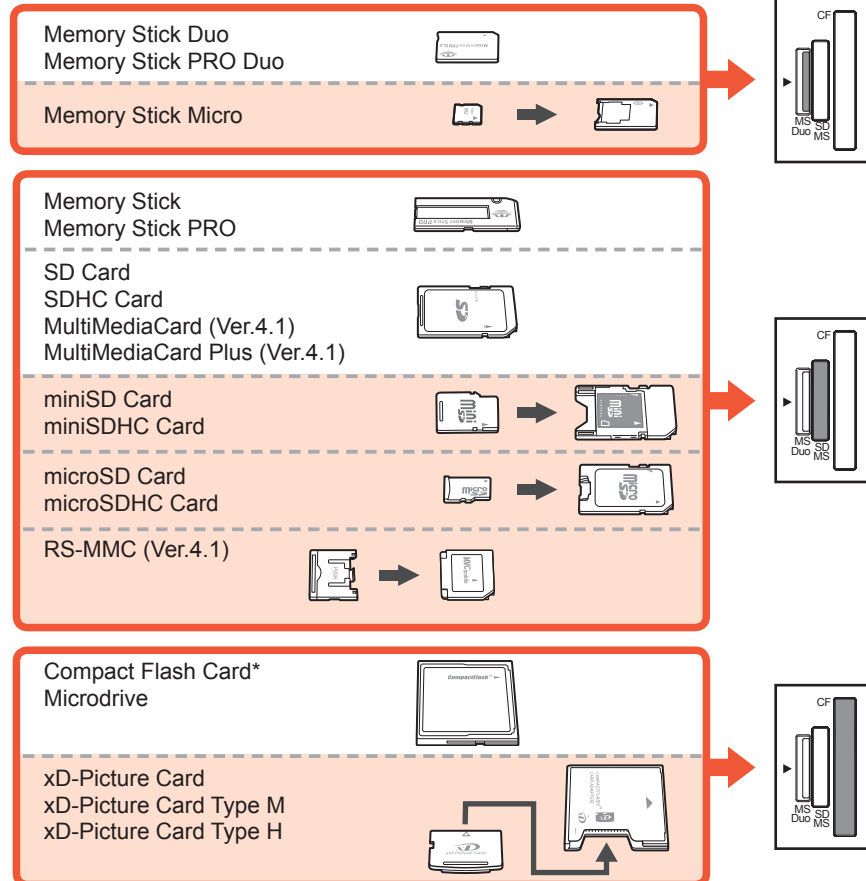

*TYPE I / TYPE II (3.3V)

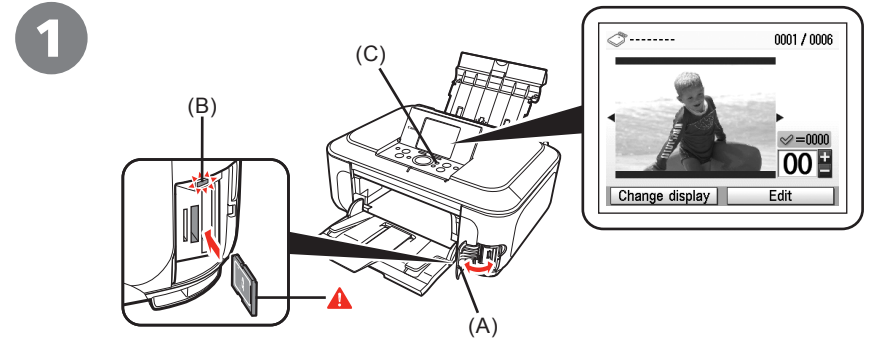

While the standby screen appears, open the Card Slot Cover (A), insert a memory card into the Card Slot, then close the Card Slot Cover (A).

Confirm that the **Access** lamp (B) has lit up. After the photos on the memory card are read, the screen to specify photos and the number of copies to print appears.



- Insert a memory card into the Card Slot in the direction of the arrow on the label, with the labeled side facing left.
- Insert only one memory card.



- Press the **HOME** button (C) to return to the standby screen.

2

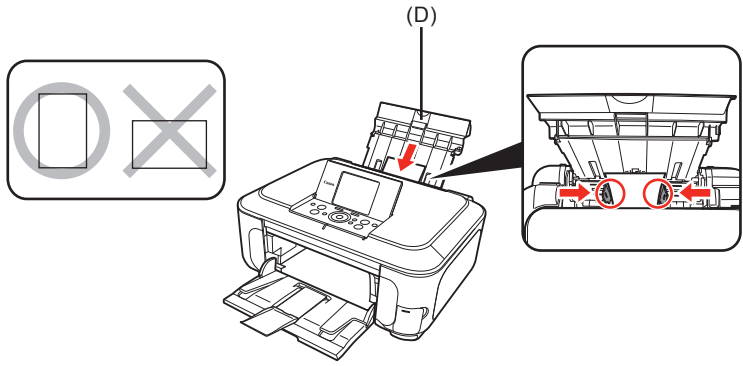

Load a sheet of 4" x 6" size photo paper in the Rear Tray (D) in portrait orientation.

3

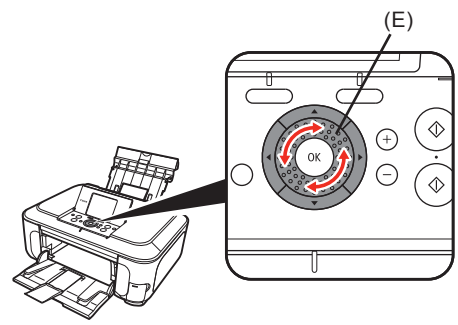

Rotate the Easy-Scroll Wheel (E) to display a photo to print.

Alternatively, use the ◀ or ▶ button to select a photo.



• For details, refer to "22 Loading Paper" on page 58.



4

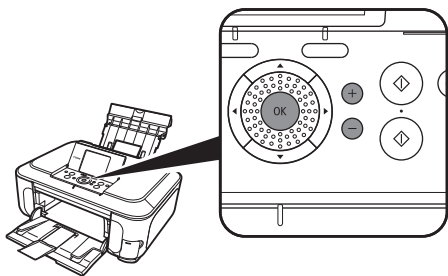

Press the **[+]** or **[-]** button to specify the number of copies, then press the **OK** button.

The Print Settings Confirmation Screen appears.

5

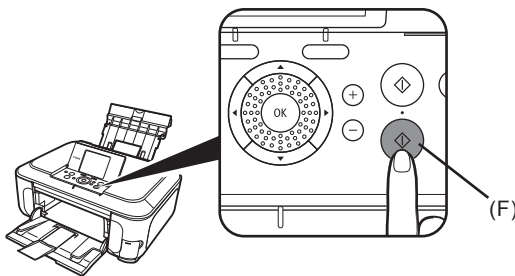

Press the **Color** button (F).

Printing will start.

6

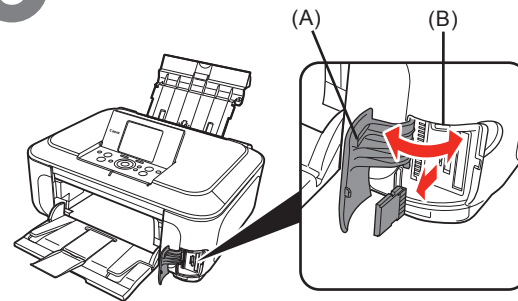

After printing, open the Card Slot Cover (A), pinch the memory card and pull it straight out, then close the Card Slot Cover (A).



- Do not remove the memory card while the **Access** lamp (B) is flashing. Saved data may be damaged.

Try Copying

You can copy a document by simply placing it on the Platen Glass and pressing the **Black** button or the **Color** button. This section explains with Plain Paper. For various copying procedures, refer to "Copying" in the on-screen manual: *Basic Guide*.

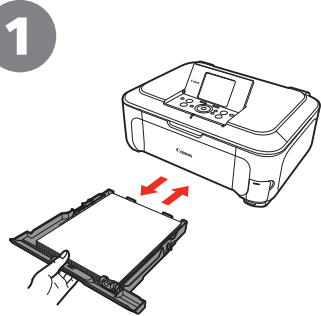

Load A4 or Letter-sized plain paper in the Cassette.



- For details, refer to "22 Loading Paper" on page 58.

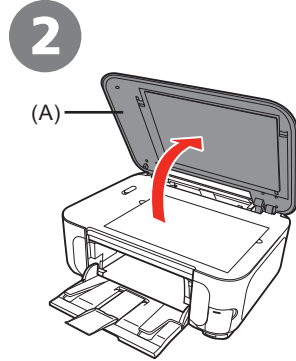

Open the Document Cover (A).

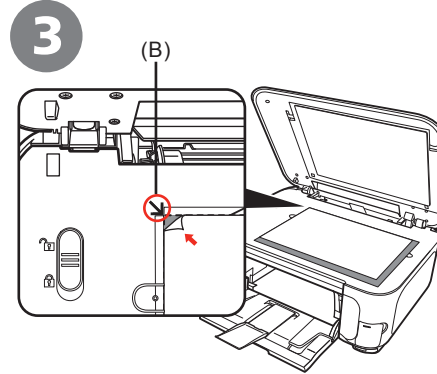

Place the document face-down and align it with the Alignment Mark (B).



- Do not place any objects weighing more than 4.4 lb / 2.0 kg on the Platen Glass.
- Do not press or put weight on the original with pressure exceeding 4.4 lb / 2.0 kg. Doing so may cause the scanner to malfunction or the Platen Glass to break.

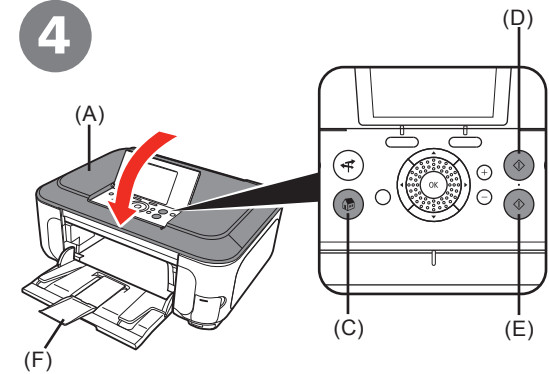

Close the Document Cover (A), press the **HOME** button (C), then press the **Black** button (D) twice for black & white copying, or the **Color** button (E) twice for color copying.

Copying will start.
Remove the document after printing.



- Do not open the Document Cover until copying is complete.
- Make sure that the Output Tray Extension (F) is extended.

Print Photos from a Computer

Easy-PhotoPrint EX allows you to print photos easily.

This section explains how to print borderless photos using 4" x 6" size Photo Paper Plus Glossy II. The screens are based on Windows Vista.

1

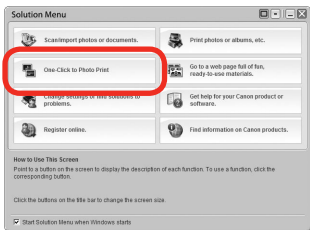

In Solution Menu, click **One-Click to Photo Print**.

Easy-PhotoPrint EX starts.

2

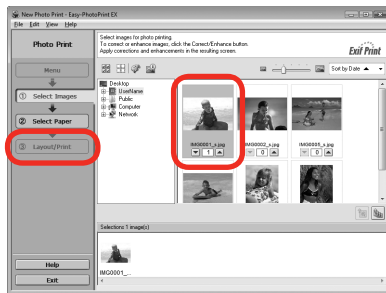

Select the image you want to print in a folder, then click **Layout/Print**.

When a photo is selected, the number of copies is set to "1."

3

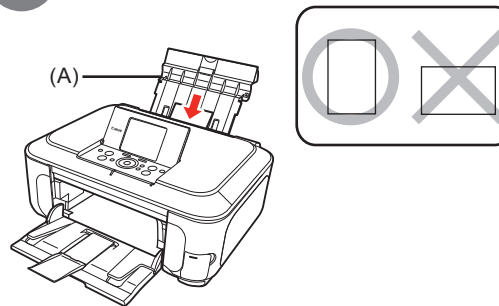

Load a sheet of photo paper in the Rear Tray (A) in portrait orientation.

Load paper with the printing side facing up.

4

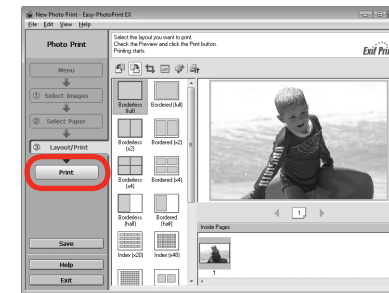

Click **Print**.

Printing will start.



- For opening Solution Menu, refer to "Solution Menu" on page 62.
- For more information refer to the on-screen manual: *Advanced Guide*.



- For details, refer to "22 Loading Paper" on page 58.



- On Macintosh, if the **Print** screen is displayed, click **Print** to start printing.

Getting Help from Canon

Email Tech Support — www.canontechsupport.com

Toll-Free Live Tech Support— (1-800-828-4040)

This option provides live telephone technical support, free of service charges, Monday-Friday (excluding holidays), during the warranty period.

Telephone Device for the Deaf (TDD) support is available at (1-866-251-3752).

Ordering Information

The following ink tanks are compatible with this product.



Order

CLI-221 Magenta	2948B001
CLI-221 Black	2946B001
CLI-221 Gray	2950B001
PGI-220 Black	2945B001
CLI-221 Cyan	2947B001
CLI-221 Yellow	2949B001

Call 1-800-OK-CANON to locate a dealer near you, or visit the Canon eStore at www.canonestore.com

www.usa.canon.com