



Unpack the Machine

- Please confirm the included items against the illustration printed on the lid of the packing box.
- A USB cable is necessary to connect the machine with your computer.



When cleaning the exterior of the machine, use a soft cloth to wipe it gently. For details, refer to "Cleaning Your Machine" in the Quick Start Guide.

1 Prepare the Machine

1 Place the machine on a flat and horizontal surface, and do not place any objects in front of the machine.

Remove all the shipping tapes and protective material on the outside of the machine.

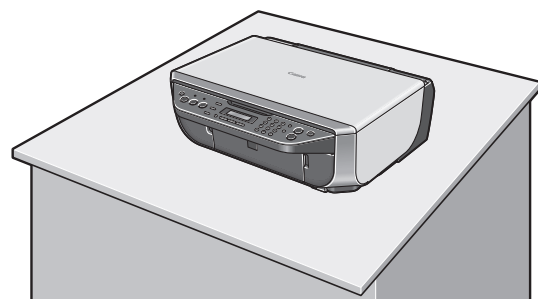

2 Lift the Scanning Unit (Printer Cover) with both hands, and pull the Scanning Unit Support down into place.

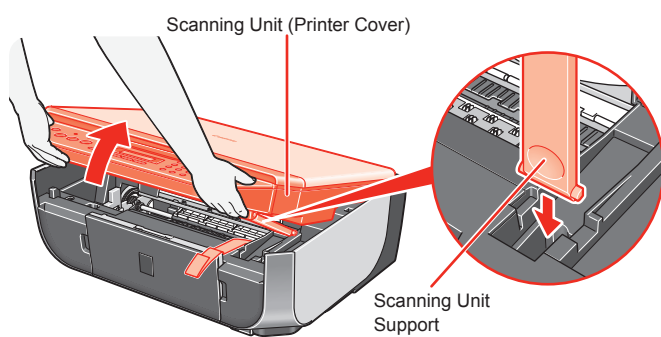

3 Remove the protective material on the right side.

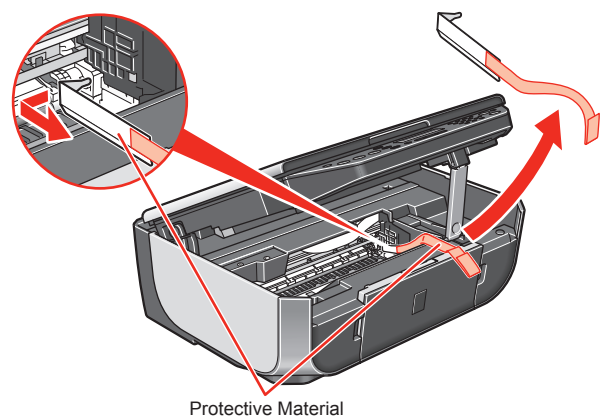

Caution Before turning on the machine, remove all of the shipping tapes.

4 Lift the Scanning Unit (Printer Cover) slightly to set the Scanning Unit Support back to its original position, and then gently close the Scanning Unit (Printer Cover) with both hands.

5 Connect the telephone line and any necessary external device. You can connect an external device (telephone or answering machine) if necessary.

Remove the Telephone connector cap to connect the external device.

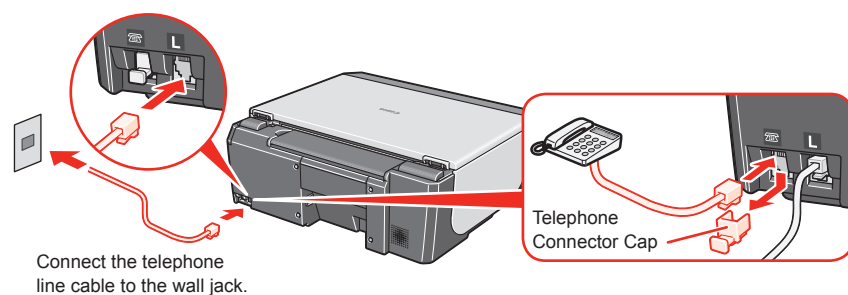

Connect external devices as follows:

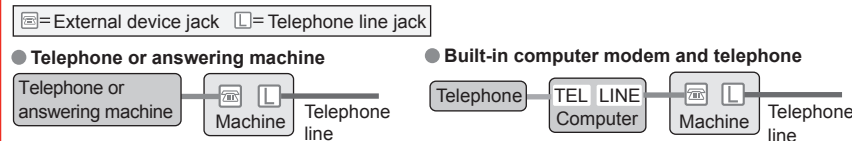

Important Be sure to use the bundled telephone line cable.

6 Plug the power cord in the back of the machine and connect the other end to the wall outlet.

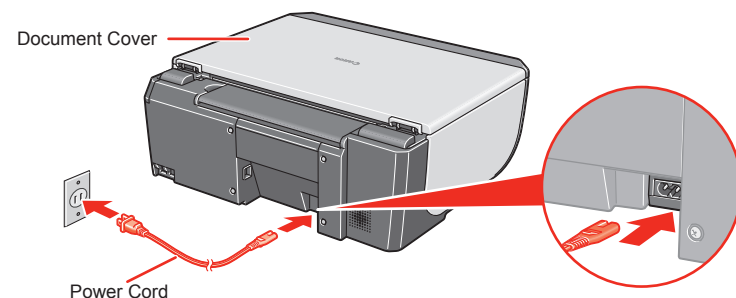

Important Make sure that the Document Cover is closed. Do NOT connect the USB cable at this stage.

7 Press the ON/OFF button to turn on the machine. The machine will initialize. Wait until the Power lamp stops flashing and remains lit green.

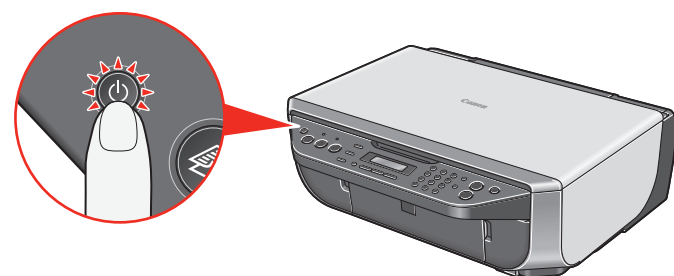

8 Press the left or right button on the Operation Panel to select the language for the LCD, then press the OK button.



Important If an unintended language is displayed on the LCD, press the Back button to return to the LANGUAGE SETTING screen. Once the message "SET INK CARTRIDGE" appears, go to 9.

9 Lift the Scanning Unit (Printer Cover) with both hands, and pull the Scanning Unit Support down into place. The FINE Cartridge Holder automatically moves to the left.

10 Write down the serial number located inside the machine. You will need this to register your product.

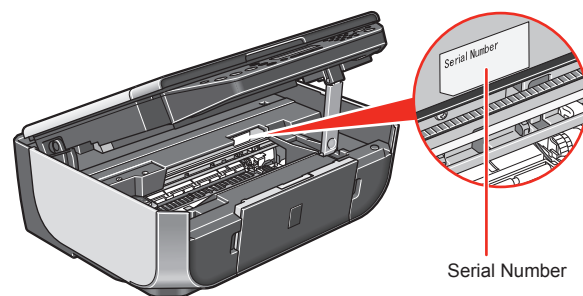

2 Install the FINE Cartridges

1 Remove the Black FINE Cartridge from its box.

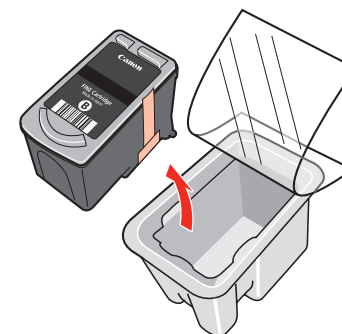

2 Remove the protective tape gently.

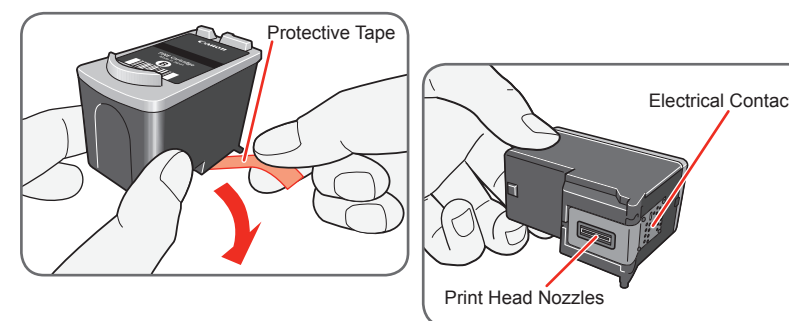

Important Do not touch the electrical contacts or Print Head Nozzles on a FINE Cartridge. The machine may not print out properly if you touch it. Do not reattach the protective tape once you have removed it. Be careful not to stain your hands or surrounding work area with ink on the removed protective tape.

3 Insert the Black FINE Cartridge slightly slanted into the left slot.

Make sure that the message "COVER IS OPEN" is displayed on the LCD and the FINE Cartridge Holder has moved to the left.

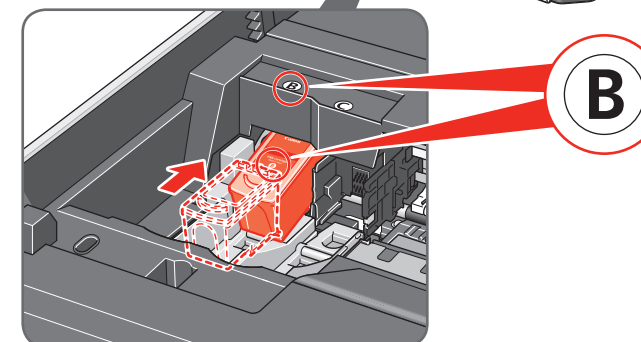
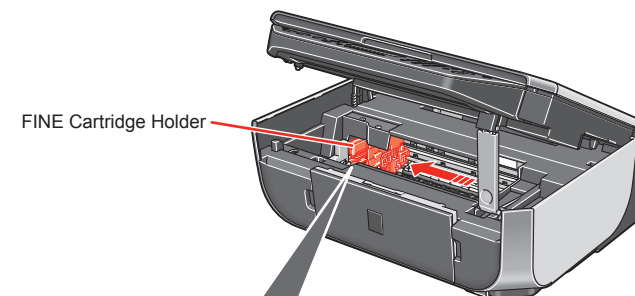

4 Push up the FINE Cartridge until it clicks into place.

Important For correct machine operation, make sure the FINE Cartridge is securely inserted.

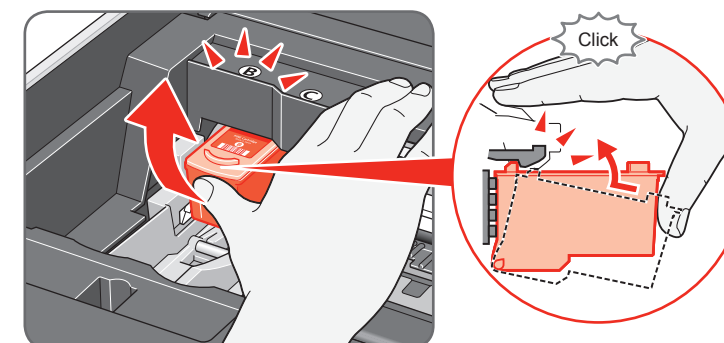

5 Repeat the procedure for the Color FINE Cartridge, inserting it into the right slot.

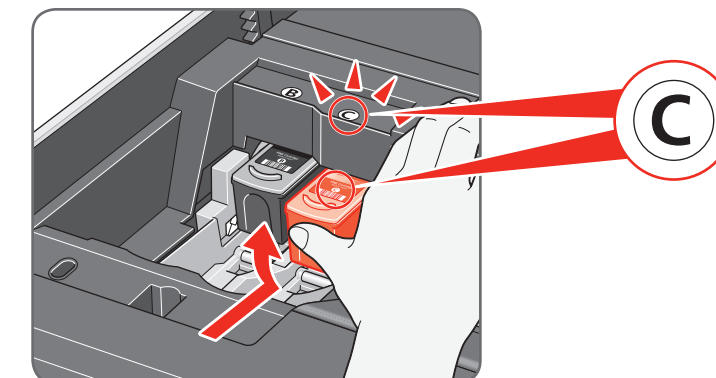

6 Lift the Scanning Unit (Printer Cover) slightly to set the Scanning Unit Support back to its original position, and then gently close the Scanning Unit (Printer Cover) with both hands.

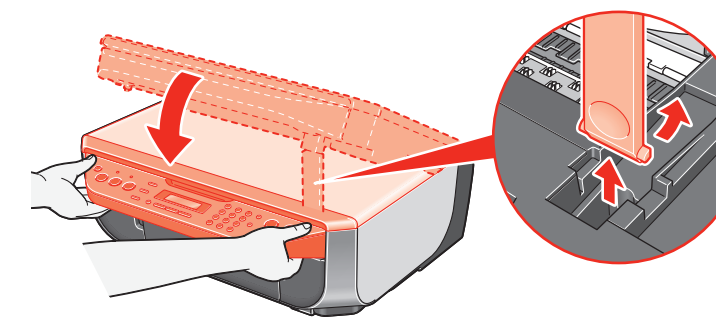

Important Once you have installed the FINE Cartridges, the message "CART. RETURN" is displayed on the LCD. Wait until the following message appears before proceeding. It takes about one minute.

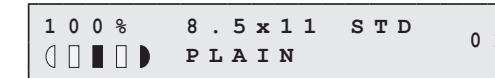

If the messages "IN CASE OF MISPRINT PLEASE ALIGN HEAD" and "CHECK THICKNESS LEVER CHECK IF THCKNESS LEVER IS SET TO LEFT" are displayed on the LCD when you start printing after preparing the machine, press the OK button on the machine. For details on how to align the Print Head position and adjust the position of the Paper Thickness Lever, refer to the Quick Start Guide.

Hardware setup is now complete. Next, turn over and install the software.

For fax users

To use a fax, you need to set the telephone line type setting properly on the machine.

If you are unsure of your telephone line type, contact your telephone company.

Select the receive mode according to your needs.

You want to receive only faxes automatically with the machine, or have a dedicated telephone line for fax use only:

→ FAX ONLY MODE

You are using a single telephone line for faxes and voice calls and use voice calls more frequently:

→ TEL PRIORITY MODE

You are using a single telephone line for faxes and voice calls and want to receive faxes automatically:

→ FAX PRIORITY MODE

You have subscribed to a Distinctive Ring Pattern Detection (DRPD) service with your telephone company:

→ DRPD

For details on how to confirm and change the settings, refer to the Quick Start Guide.

Windows® Software Installation

Windows

Note

- The screens below refer to Windows Vista™ operating system Ultimate Edition (hereafter referred to as "Windows Vista") installation. Screens may vary depending on the operating system you are using.
- Log into a user account with the administrator privilege.
- Before installing the software, disable all anti-virus programs and automatically loading programs.
- A message asking for your confirmation to restart your computer may appear during the installation process. If this message is displayed, follow the on-screen instructions and click **OK**. The installation resumes from where it left off when your computer has been restarted.

1 Be sure to **TURN THE MACHINE OFF** before continuing.

- Press the **ON/OFF** button.
- Make sure that the **Power** lamp stops flashing.

2 Turn the computer on and start Windows.

Important

If the **Found New Hardware** or **Found New Hardware Wizard** screen appears automatically, remove the USB cable connected to your computer. Click **Cancel** to quit the screen. In Windows Vista, the screen may close automatically when the USB cable is unplugged. Then turn off the machine and proceed from step **3** to install the software.

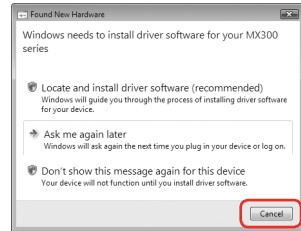

3 Insert the Setup CD-ROM. The setup program should run automatically.

In Windows Vista, go to Step **4**. In Windows XP and Windows 2000, go to Step **6**.

4 If the **AutoPlay** screen appears, click **Run Msetup4.exe**.

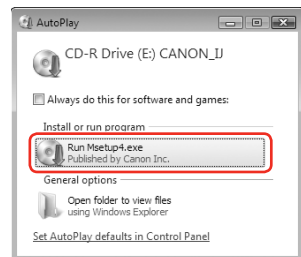

5 If the **User Account Control** screen appears, click **Continue**. If the same screen reappears in subsequent steps, click **Continue**.

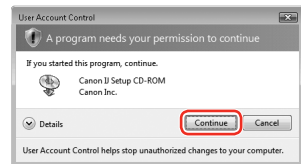

6 When the main menu appears, click **Easy Install**.

The MP Drivers, On-screen Manuals, and application software are installed automatically.



Note

If you want to select particular items to install, click **Custom Install** and follow the on-screen instructions to proceed with the installation.

7 When the list of applications to install appears, confirm the contents, then click **Install**.

Note

Move the cursor over items to display explanations of each application.

8 Read the License Agreement carefully and click **Yes**. The software installation screen may appear during the installation process. Follow the on-screen instructions to install the software.

9 When the **Printer Connection** screen appears, connect one end of the USB cable to the computer, the other to the machine, then **TURN THE MACHINE ON**. The MP Drivers will begin identifying the printer port being used.

Important

If you cannot go to the next procedure after three minutes, refer to "Troubleshooting" instructions in the *User's Guide* on-screen manual.

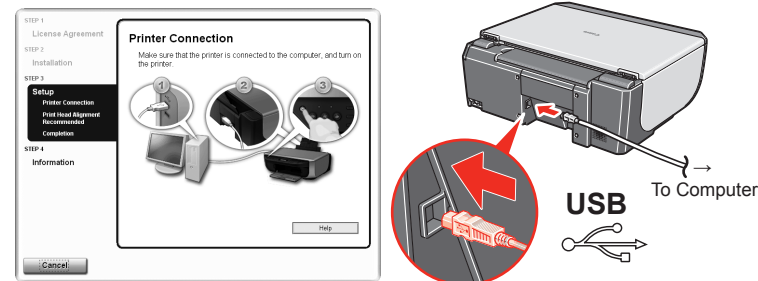

10 When the **Print Head Alignment Recommended** screen appears, click **Next**.

11 When the **Setup Complete** screen appears, click **Next**.

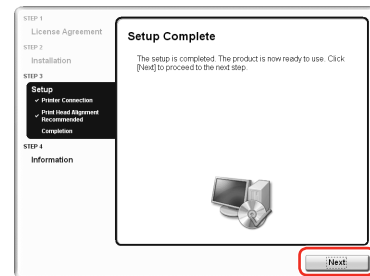

12 When the **User Registration** screen appears, click **Next**.

Note

To register later, click **Cancel** and go to Step **13**. After software installation is complete, double-click  on the desktop.

Follow on-screen instructions to register your product. You will need your product serial number, which is located on the inside of the machine. See Step 1- **10** on the front page.

13 When the **PIXMA Extended Survey Program** screen appears, confirm the message. We would appreciate it if you would take part in this program regarding the use of Canon printers. If you can agree, click **Agree**.

14 When the **Installation completed successfully** screen appears, click **Exit**.

If **Restart** is displayed, make sure that the **Restart the system now (recommended)** check box is selected, then click **Restart**.

Note

If straight lines are misaligned or print quality is not satisfactory after installing the MP Drivers, you may need to align the Print Head. Refer to "Aligning the Print Head" in the *Quick Start Guide*.

Software installation is now complete.

Macintosh® Software Installation

Macintosh

Note

- Since Mac® OS 9, Mac OS X Classic environments, or Mac OS X v.10.2.7 or earlier are not supported, do not connect the machine to these.
- The screens below refer to Mac OS X v.10.4.x installation. Screens may vary depending on the operating system you are using.
- Log on as an Administrator.
- Before installing the software, disable all anti-virus programs and automatically loading programs.

1 Connect one end of the USB cable to the computer and the other to the machine.

Note

Make sure the machine is turned on.

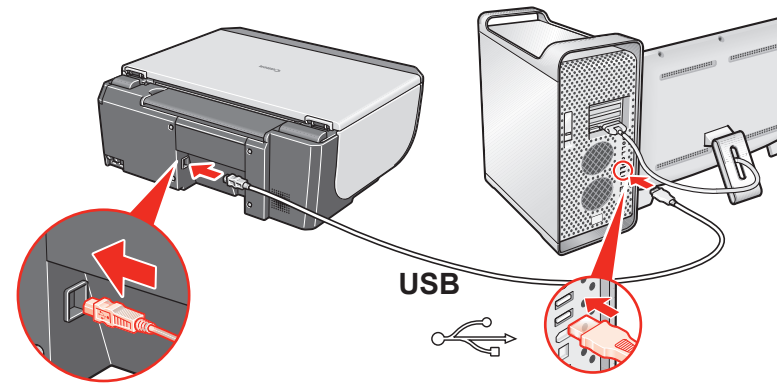

2 Turn on your Mac and insert the Setup CD-ROM.

Note

If the CD-ROM folder does not open automatically, double-click the CD-ROM icon  on the desktop.

3 Double-click the **Setup** icon.

4 When the **Authenticate** screen appears, enter your administrator name and password. Click **OK**. If you do not know your administrator name or password, click , then follow the on-screen instructions.

5 When the main menu appears, click **Easy Install**.

The MP Drivers, On-screen Manuals, and application software are installed automatically.

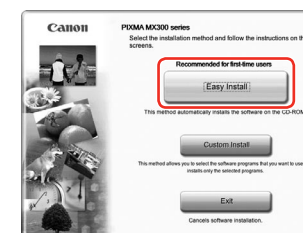

Note

If you want to select particular items to install, click **Custom Install** and follow the on-screen instructions to proceed with the installation.

6 When the list of applications to install appears, confirm the contents, then click **Install**.

Note

Move the cursor over items to display explanations of each application.

7 Read the License Agreement carefully and click **Yes**. The software installation screen may appear during the installation process. Follow the on-screen instructions to install the software.

8 When the **Print Head Alignment Recommended** screen appears, click **Next**.

9 When the **Setup Complete** screen appears, click **Next**.

10 When the **User Registration** screen appears, click **Next**.

Note

To register later, click **Cancel** and go to Step **11**. After software installation is complete, double-click  on the desktop.

Follow on-screen instructions to register your product. You will need your product serial number, which is located on the inside of the machine. See Step 1- **10** on the front page.

11 When the **Installation completed successfully** screen appears, click **Restart**.

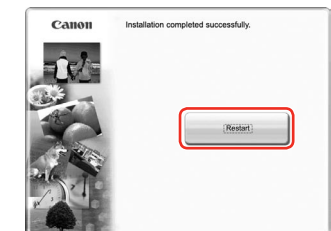

The system is restarted automatically.

When using Mac OS X v.10.2.8 to v.10.3.3:

Restarting the computer while connected to the machine may cause the machine not to be detected. To resolve this, either unplug the USB cable then plug it back in again, or turn the machine off then back on again.

Note

- When using Mac OS X v.10.2.8 to v.10.3.x, before using the Operation Panel on the machine to save originals scanned from the Platen Glass to the computer, it is necessary to select **MP Navigator EX 1.0** or **MP Navigator EX 1** as the launch application on Image Capture under **Applications**. For details, refer to "Scanning Images" in the *User's Guide* on-screen manual.
- If straight lines are misaligned or print quality is not satisfactory after installing the MP Drivers, you may need to align the Print Head. Refer to "Aligning the Print Head" in the *Quick Start Guide*.
- XXX FAX** (where "XXX" is your machine's name) is shown in the **Printer Name** list (**Product** list in Mac OS X v.10.2.8 to v.10.3.x), but you cannot add **XXX FAX**. You can fax the document with the current print settings applied to it if your computer is equipped with an internal modem. You cannot send faxes from your computer via the machine.

Software installation is now complete.