

DP-V1710

Video Display

- Before use, be sure to read this guide, including the safety and handling precautions.
- Reading this guide will help you learn to use the video display properly.
- Store this guide safely so that you can use it in the future.

Instruction Manual

English

Table of Content

2

Introduction 3

- About this manual 3
- Trademarks 3
- Supplied Accessories 3

Important Usage Instructions 4

Safety Instructions and Handling

- Precautions 5

Features 10

Nomenclature 11

Installation/Connection 13

- Carrying the video display 13
- Removing the carrying handle 13
- Attaching the protective plate: PP-17U Protect Panel (sold separately) 14
- Removing/attaching the stand 15
- Preventing from Tipping 16
- Mounting the Main Unit on a Stand or Wall 17
- Mounting the Main Unit on a 19 Inch Rack: RB-02 Rack Mount Bracket (sold separately) 18
- Connecting the Main Unit to Input Devices 20

Turning on the Power 22

- Turning on the Power of the Main Unit 22
- Attaching/detaching the HC-01 AC Power Cord Clamp (provided) 23

Operating the Video Display 24

- Basic operations to use the OSD menu 24
- Adjusting Image Quality While Viewing the Entire Image 25
- Temporarily Saving Parameters (Anchor Point Setting) 27
- Enlarging the display (Zoom function) 27
- Adjusting image quality for each screen in two screen display 28

Changing the screen display area (for video of 4096x2160) 28

Performing calibrations 28

Export/Import 30

Set Date/Time 32

Inputting Characters 32

Using the Function (F) Buttons 33

Using the Channel (CH) Button 33

Checking Signal Information and Status of the Main Unit 34

Operating the video display using an external device [REMOTE terminal(GPI)] 34

Operating the video display using an external device [LAN terminal] 35

OSD Menu 36

- OSD Menu Index 36
- Adjustment 40
- Channel Settings 53
- Display Settings 56
- Audio Settings 59
- Marker Settings 60
- Function Settings 65
- System Settings 72
- Signal Information 78
- System Information 78

Main specifications/Performance 79

- Dimensions 81

Appendix 82

- Supported Signal Format 82
- Image/Frame Display 96

Error Messages 99

Troubleshooting 102

Software Used in This Product 104

Index 106

Introduction

Thank you for purchasing the Video Display DP-V1710.

The On Screen Display (thereafter referred to OSD) default language setting is English. To change the OSD menu language setting, please refer to p. 72.

About this manual

Some of the illustration used in the manual have been simplified for clarity.

Conventions used in this manual

: Indicates a reference page.

 Note: Indicates a note.

 Reference: Indicates reference information.

 CAUTION: Indicates an item you must observe.

Trademarks

- HDMI, HDMI logo, and High-Definition Multimedia Interface are trademarks or registered trademarks of HDMI Licensing LLC in the U.S. and other countries.
- VESA is a registered trademark or trademark of Video Electronics Standards Association in the U.S. and other countries.
- Other product and company names herein are trademarks or registered trademarks of their respective owners.

Supplied Accessories

The following items are supplied with this product. Please check before using.



AC Power Cord HT-21

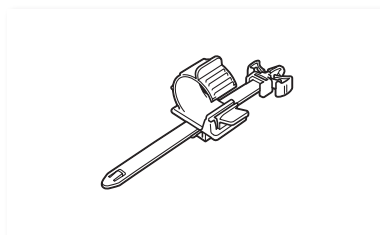

AC Power Cord clamp
HC-01

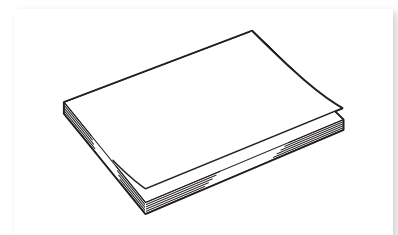

DP-V1710 Instruction Manual
(this document)

Important Usage Instructions

4 For the customers in the U.S.A.

This equipment has been tested and found to comply with the limits for a Class A digital device, pursuant to Part 15 of the FCC Rules.

These limits are designed to provide reasonable protection against harmful interference when the equipment is operated in a commercial environment. This equipment generates, uses, and can radiate radio frequency energy and, if not installed and used in accordance with the instruction manual, may cause harmful interference to radio communications. Operation of this equipment in a residential area is likely to cause harmful interference in which case the user will be required to correct the interference at his own expense.

Do not make any changes or modifications to the equipment unless otherwise specified in the manual. If such changes or modifications should be made, you could be required to stop operation of the equipment.

Use of shielded cable is required to comply with class A limits in Subpart B of Part 15 of FCC Rules.

This device complies with Part 15 of the FCC Rules. Operation is subject to the following two conditions: (1) This device may not cause harmful interference, and (2) this device must accept any interference received, including interference that may cause undesired operation.

Canon U.S.A Inc.
One Canon Park, Melville, NY 11747, U.S.A.
Tel No. (631)330-5000

For the customers in Canada

CAN ICES-3 (A) / NMB-3 (A)

For the customers in Europe

Warning;

This is a class A product. In a domestic environment this product may cause radio interference in which case the user may be required to take adequate measures.

CANON INC.
30-2, Shimomaruko 3-chome, Ohta-ku, Tokyo 146-8501, Japan

CANON EUROPA N.V.
Bovenkerkerweg 59, 1185 XB Amstelveen, The Netherlands



Only for European Union and EEA (Norway, Iceland and Liechtenstein)

This symbol indicates that this product is not to be disposed of with your household waste, according to the WEEE Directive (2012/19/EU) and national legislation. This product should be handed over to a designated collection point, e.g., on an authorized one-for-one basis when you buy a new similar product or to an authorized collection site for recycling waste electrical and electronic equipment (EEE). Improper handling of this type of waste could have a possible negative impact on the environment and human health due to potentially hazardous substances that are generally associated with EEE. At the same time, your cooperation in the correct disposal of this product will contribute to the effective usage of natural resources. For more information about where you can drop off your waste equipment for recycling, please contact your local city office, waste authority, approved WEEE scheme or your household waste disposal service. For more information regarding return and recycling of WEEE products, please visit

www.canon-europe.com/weee

Safety Instructions and Handling Precautions

Be sure to read these instructions in order to operate the product safely.
Follow these instructions to prevent injury or harm to the operator of the product or others.

WARNING

Denotes the risk of serious injury or death.

- **Do not disassemble or modify the video display.**
Inside, the video display contains high-voltage/extremely hot/movable parts that can cause fire, electric shock, burns or injury.
- **Do not insert foreign objects or liquids into the video display.**
If metallic objects, flammable objects or liquids get inside the video display, this may cause fire, electric shock or malfunction.
- **Be sure to use the correct voltage.**
Using a power source with a voltage other than that specified in this instruction manual can cause fire or electric shock. Always use the supplied (or specified) AC power cord. For your safety, do not use this AC power cord to power other equipment.
- **Do not connect non-standard input voltage to the DC input terminal.**
Applying non-standard input voltage to the DC input terminal can cause a fire or electric shock.
- **Do not use the video display in the following places.**
Doing so can cause fire, electric shock or malfunction.
 - Close to a window when it is raining or snowing.
 - Places subject to high humidity and dust.
 - Places exposed to water and moisture such as bathrooms, kitchens etc.
 - Places directly exposed to dust, smoke or steam, or nearby heaters and humidifiers.
 - Places where flammable gases may be present.
 - Places exposed to direct sunlight.
- **Do not install or store the video display in places exposed to direct sunlight.**
The video display's internal temperature can rise and cause fire or malfunction.
- **Do not damage the power cord.**
Do not place heavy objects on the power cord and do not pull, modify, heat or tie the power cord in a bundle. The power cord may be damaged (exposed or broken wires, etc.) and cause fire or electric shock.
- **When using three-pronged plugs with a ground connection:**
Always connect the ground prong.
A short circuit occurring when the ground prong is not connected can cause fire or electric shock.
The video display's power cable features a three-pronged plug.
- **Do not touch the power cable or plug during lightning storms.**
This can cause electric shock.
- **Do not touch the power cable or plug with wet hands.**
This can cause electric shock.

- **Observe the following precautions regarding the power source and power plug.**

Failing to do so can cause fire or electric shock.

- Insert the power plug fully and securely into the power outlet. Do not use a damaged power cable or plug or a loose power outlet.
- Hold the plug itself when unplugging the power cable. Pulling the power cord can damage the power cord and cause fire or electric shock.
- Periodically remove any dust buildup from the power plug.
- Do not obstruct the access to the power plug by placing other objects around it.
- Do not connect many power cords to the same power outlet.
- When using an extension cable, make sure the total power consumption of the devices you connect to the extension cable does not exceed its rated power.

- **If the video display was dropped or exposed to a strong impact, turn it off immediately and unplug the power plug.**

The video display is a precision instrument and continued use in such case can result in a short circuit and cause fire or electric shock.

- **Before starting any maintenance work, turn off the video display and unplug the power plug.**

Failing to do so can cause electric shock.

- **In any case of unusual circumstances such as the presence of smoke or abnormal sounds or smell, immediately turn off the video display and unplug the power plug.**

Continued use can cause fire or electric shock.

- **Before moving, installing, removing or connecting the video display to peripheral devices, turn off the video display and all connected devices and unplug their power plugs.**

Failing to do so can cause fire, electric shock or malfunction.

- **For your safety, unplug the power plug from the power outlet when not using the video display for extended periods of time.**

Dust buildup on the power plug can cause fire.

- **Do not obstruct the access to the power plug so it can always be easily unplugged.**

Failing to disconnect the power plug immediately after unusual circumstances have occurred can cause fire or electric shock.

- **Do not block the ventilation holes.**

Blocking the video display's vent holes can result in the internal temperature rising and cause fire or malfunction. Observe the following precautions to ensure proper ventilation.

- Do not push the video display into narrow confined spaces or enclosures.
- Do not wrap the video display in cloth or other materials.
- Do not place the video display facing up, lay it sideways or upside-down.

- **If the screen is damaged, do not touch the leaking liquid crystal or other internal liquids.**

If the LCD panel is damaged and liquid crystal or other internal liquids leak out, do not put the liquids in the mouth, inhale or swallow it or let it come in contact with the skin. If the liquids get in the eye or mouth, wash it immediately with plenty of water. If the liquids come in contact with the skin or clothes, wipe them immediately with alcohol etc. and wash the exposed area with soap. Leaving the liquids untreated can cause injury or damage.

- **Use the carrying handle to carry the video display.**

When carrying the video display, be sure to hold it by the carrying handle. Failure to do so could cause the display to fall and cause an injury.

- **Keep all packaging material out of the reach of children.**

Packaging material tightly wrapped around someone's head can result in strangulation or suffocation.

 **CAUTION**

Denotes the risk of injury.

- **Do not place any objects on the video display and do not climb on it.**
The video display can tip or fall and cause injury.
- **Do not install the video display on an unstable surface.**
Installing the video display on a wobbly or slanted surface can cause the display to tip or fall and cause injury. Thoroughly check also the strength and sturdiness of the surface where the video display will be placed or installed.
- **Take precautions to prevent the video display from tipping or falling.**
In an earthquake the video display can tip or fall. For your safety, when installing the video display on a TV stand or other furniture, take precautionary measures to secure the video display against tipping or falling (📖 16). Taking such measures can be effective in reducing the risk of injury or damage but the effectiveness of the prevention measures cannot be guaranteed in all earthquakes.
- **Always follow the specified procedure to install the video display (📖 13).**
If the installation is not performed correctly, the video display may tilt or fall and cause injury.
- **Inspect the condition of the installation about once per year.**
An inadequate fitting or mounting can cause the video display to fall and cause injury.
- **Regularly check to ensure that the carrying handle remains securely attached.**
If the carrying handle screws are loose or broken, the display could fall and cause an injury.
- **Attach the carrying handle securely.**
The carrying handle screws should be tightened securely, if they have ever been removed. Failure to do so could cause the display to fall and cause an injury.
- **When using headphones, set the volume at a safe level.**
Listening through headphones at a high volume can harm your hearing.

When Using the Main Unit

- The screen may be damaged if it is left facing strong source of light. Please take precautions when placing it near a window.
- Do not press firmly on the screen, scratch it or place an object on the screen. It can cause non-uniformity or damage to the panel.
- The screen and cabinet may become warm during use. Note this does not constitute a malfunction.

About Backlight

The backlight has a limited service life so its brightness may degrade and color may change due to aging.

About Temporary Screen burn-in

If a stationary image is displayed for a prolonged period, screen burn-in may occur where you see remnants of what was displayed. This is a characteristic of LCD and is not a failure. However, this is only temporary and will disappear when playing video.

About the LCD screen

The screen is produced using extremely high-precision manufacturing techniques, with more than 99.99% of the pixels operating to specification. Less than 0.01% of the pixels may occasionally misfire or appear as black, red, blue or green dots. In addition, this tendency may increase through long term use due to characteristic of the LCD panel. These do not constitute a malfunction.

Condensation

If this equipment is brought into a warm room while it is cold or if the room is heated suddenly, condensation may form on the surface or inside the equipment. Note that the equipment may be damaged if it is used under such condition. If condensation has formed on the surface or inside the equipment, do not use the video display as it may get damaged. Turn the power off and wait until the condensation has evaporated before using the video display.

Cleaning

- Before cleaning, be sure to unplug the power plug.
- The screen has a special surface treatment, avoid touching it directly with your hand. In addition, never affix adhesive objects such as seals.
- Never use alcohol or benzene, thinner, acidic cleaning solution, alkaline cleaning solution, abrasive or chemical wipes because these will damage the screen.
- If the screen is dirty, wipe gently with soft dry cloth such as cleaning cloth or eye glasses cleaning cloth. Wiping the screen too hard may cause unevenness on the screen or damage the LCD panel. The screen may be scratched if wiped too hard with a cleaning cloth with foreign particles attached.
- When the screen is extremely dirty, wipe with soft cloth such as cleaning cloth or eye glasses cleaning cloth moistened with water-diluted neutral detergent.
- Use a blower to remove dust from the surface of the screen.
- Wipe dirt on cabinet with a soft cloth. If the screen is very dirty, use a moistened cloth with water or mild detergent diluted with water. Do not use alcohol, benzene, paint thinner, or pesticides as they may damage the surface finish or erase characters on the cabinet.

Disposing

- Do not dispose together with normal waste. Do not include the video display in waste that will be taken to landfill.
- Observe the rules and regulations of your local authorities when disposing.

Features

10 The DP-V1710 Video Display provides a wide range of support for video production as a way to check video on location, in a secondary control room in a studio, or in a live broadcast vehicle.

17-Inch 4K display

- Supports UHD broadcast standard (3840x2160)
- Allows for high adjustment precision and high contrast.
- Works with 19-inch rack mount (7U) (complies with EIA standards)
- High uniformity is provided by minimizing the variation due to temperature changes and aging.
- Supports a range of color gamut standards (ITU-R BT.2020, ITU-R BT.709, etc.)
- Equipped with the HDR display function. (SMPTE ST 2084 and Hybrid Log-Gamma are supported)

Includes a range of interfaces to improve ease of use.

- Supports 6G-SDI.
- Supports DC 12 V input (4 XLR pins).
- Includes the REMOTE terminal (GPI) and LAN terminal to allow control from an external device.
- Grading controllers and calibration sensors can be connected from outside using USB ports. (Tangent Wave's Element-Tk, Konica Minolta's CA-310, etc.)

Supports a wide range of workflows on location from videoing to editing.

- Supports 4K RAW. A 4K RAW workflow is constructed on ACES2065-1.
- CINEMA EOS SYSTEM link (Supports “Canon Log”, “Canon Log 2”, and “Canon Log 3”. Equipped with functions to display the camera shooting information and automatically switch adjustment, and to stop the fan in conjunction with the camera REC signal using meta information from the camera.)
- ARRI Camera System link (Supports the ARRI Cinema Camera Look. Equipped with functions to display the camera shooting information and automatically switch adjustment, and to automatically switch the area marker size using meta information from the camera.)
- Supports multiple LUT/CDL settings.
- Supports the “2 Sample Interleave” signal transmission method.
- Supports dual screen and quad screen displays. HDR and SDR content can be displayed for comparison and image quality adjustment using the dual-screen display.
- Includes built-in Wave Form Monitor, Vector Scope, Zoom, Peaking, False Color, and more.
- Includes a tally light.

Rigidity and flexible installation

- High durability achieved by a metal outer covering
- Includes a convenient carrying handle for portability and a stand designed to ensure stability and prevent tipping.

Nomenclature

Front face of the main unit

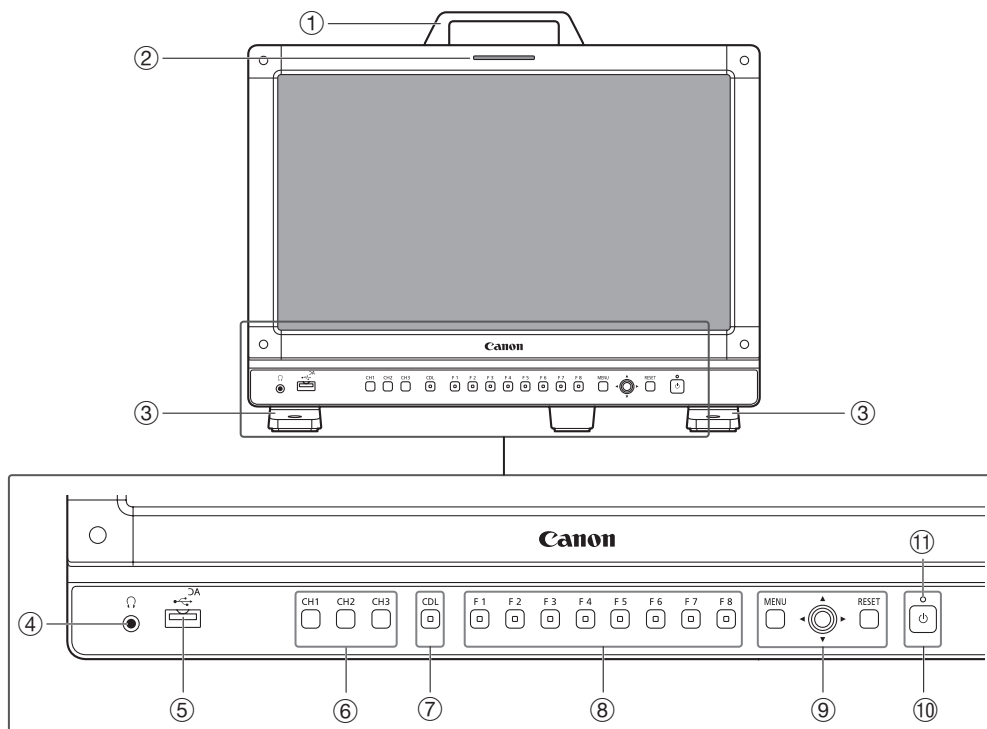

- ① Carrying handle (13)
- ② Tally light (34)
- ③ Front stand (15)
- ④ Headphone terminal (59)
- ⑤ USB port
For connecting an external sensor for calibration (28), USB memory, hub, or color grading controller (Element-Tk made by Tangent Wave Ltd).
- ⑥ Channel (CH) button CH1 to CH3 (33)
- ⑦ CDL button
For switching CDL mode.
- ⑧ Function (F) button F1 to F8 (33)
- ⑨ MENU button (24)
Jog dial (24)
RESET button (24)
- ⑩ (Power) button (22)
- ⑪ Power indicator (22)

Back face of the main unit

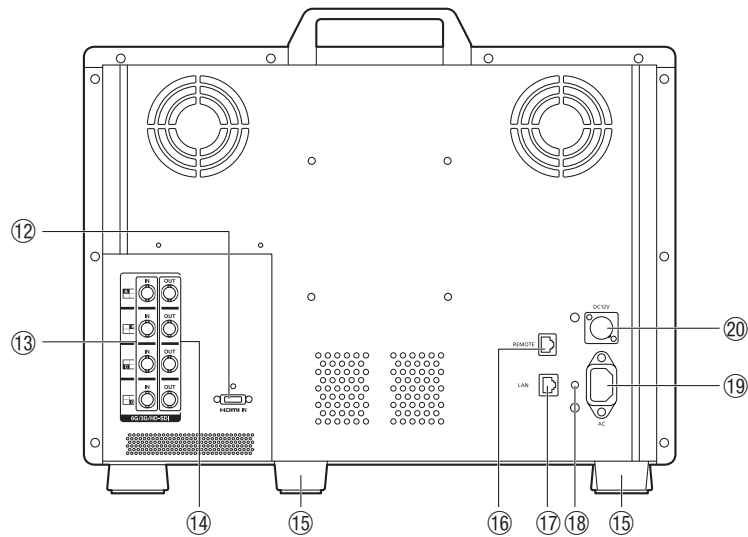

- ⑫ HDMI input terminal (📖 21)
- ⑬ 6G/3G/HD-SDI input terminal (📖 20)
- ⑭ 6G/3G/HD-SDI output terminal
For passing through output corresponding to ⑬.
- ⑮ Rear stand (📖 15)
- ⑯ REMOTE terminal (📖 34)
For connecting remote control devices.
- ⑰ LAN (10/100 BASE) terminal (📖 35)
For connecting a Display Controller CL-01 (provided with the DP-V3010) and external control device.
- ⑱ Cord clamp mounting hole (📖 23)
- ⑲ AC power input terminal (📖 22)
- ⑳ DC power input terminal (📖 22)

! CAUTION

- When connecting an external sensor for calibration to the USB port, the USB cable length must not exceed 3 m (9.8 ft.). Otherwise, communication error may occur and correct calibration may not be possible.
- For safety, do not connect any connector that may have excessive voltage to the terminal of the video display when connecting peripheral devices.

i Note

- About USB Memory
 - Both FAT16 and FAT32 USB memory devices are supported.
 - Proper operation cannot be guaranteed for all USB memories.
 - It may take 10 seconds or more for the USB memory to be recognized. If the function to save data on a USB memory is executed during recognition, the message [Detecting USB memory] is displayed.
- When using a Display Controller CL-01 (provided with the DP-V3010) with the main unit, update the controller firmware version to 4.19.0 or later.

Carrying the video display

When carrying the video display, be sure to hold it by the carrying handle.

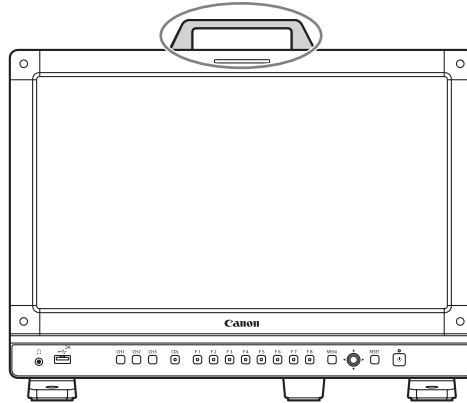

! CAUTION

- When carrying the video display, handle it carefully not to touch or damage the screen.

Removing the carrying handle

The carrying handle can be removed.

- 1 Remove the two screws from the carrying handle, as shown in the diagram below.
 - Use a hexagonal key (6 mm).
 - Do not lose the screws or carrying handle you removed. Do not use these for other purposes.

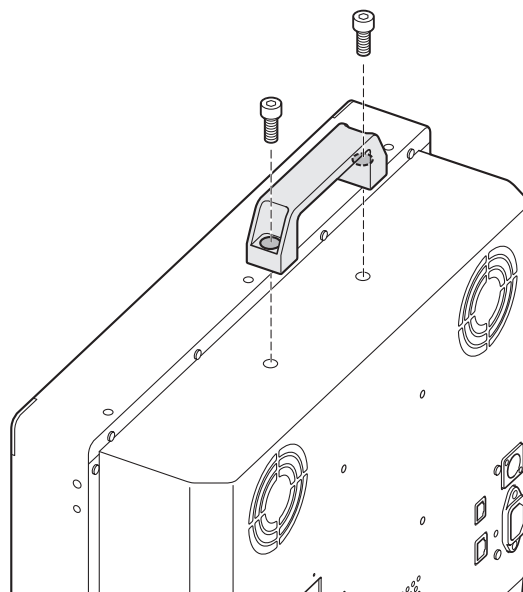

! CAUTION

- Ensure that you do not touch or damage the screen during this process.
- When attaching a carrying handle to the video display, check that it's securely attached after fastening the screws.

Attaching the protective plate: PP-17U Protect Panel (sold separately)

You can attach the protection panel to protect the screen when carrying the video display or when using it outdoors. The separately-sold PP-17U Protect Panel is attached as follows. Please also see the instruction manual for the PP-17U Protect Panel.

! CAUTION

- Avoid touching the screen during this step as it may damage it.

Use the HK-02 Hex Key for the Protect Panel (the 1.5 mm hexagonal key that is supplied with the Protect Panel) to remove or attach the screws.

1 Unscrew the four screws on the front face of the display.

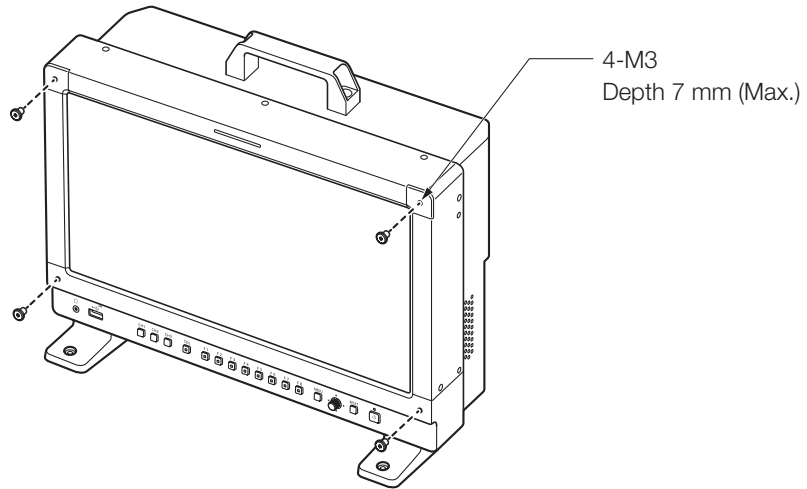

2 Remove the protective film from both sides of the Protect Panel.

3 Line up the Protect Panel and the display screw holes and fasten the screws from Step 1.

- Take care when attaching the Protect Panel in order to avoid damaging it.

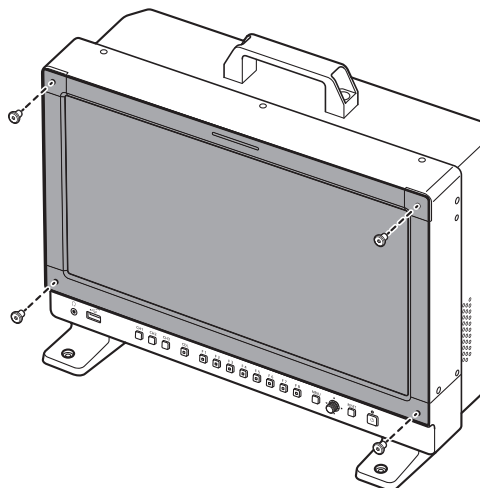

i Note

- When viewing the screen with the Protect Panel in place.
 - The colors and brightness may appear different with and without the panel in place.
 - Light may reflect off the screen.

Removing/attaching the stand

The main unit is supplied with two stands which can be detached.

! CAUTION

- Use a flat, clear surface when attaching/detaching the stands.
- The display can tip over if the stand has not been attached.
- Avoid touching the screen during this step as it may damage it.

Detaching

- 1 Place the display with the screen facing down on a soft cloth or cushioning material that is larger than the display.
- 2 Front stand: Remove the mounting screws (two each) from the left and right stands.
Rear stand: Remove the mounting screws (one each) from the left and right stands.
 - Do not lose the removed screws. Do not use these screws for other purposes.

Attaching

- 1 Place the display with the screen facing down on a soft cloth or cushioning material that is larger than the display.
- 2 Align the position of the stand and screw hole on the video display.
 - Align the convex part of the stand and concave part of the video display.
- 3 Front stand: Fix the left and right stands using the mounting screws (two each).
Rear stand: Fix the left and right stands using the mounting screws (one each).

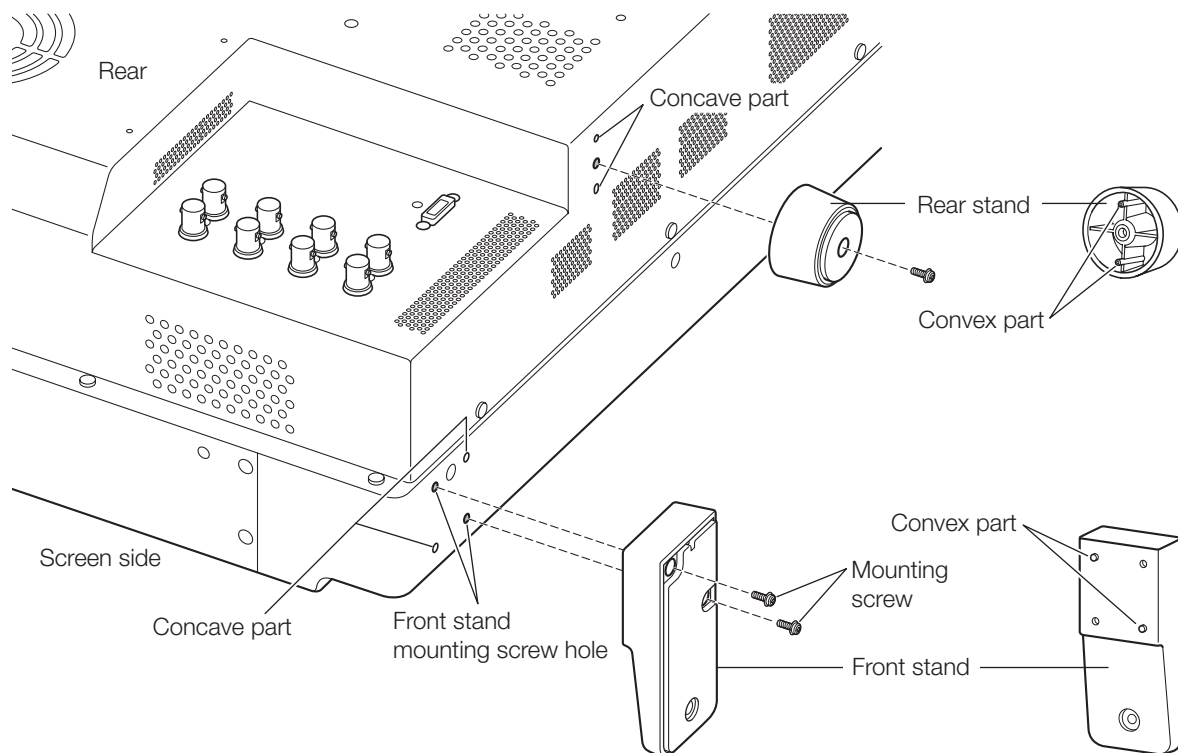

Preventing from Tipping

The video display can be fastened down to a desk or table by using the screw holes on the stand.

16

! CAUTION

- When securing the main unit to a table or desk, please ensure the table or desk is strong enough to carry the weight of the main unit.
- It is recommended to obtain assistance from another person when performing this step.
- Avoid touching the screen during this step as it may damage it.

1 Use screws that fit the screw holes to fasten it to a desk or table.

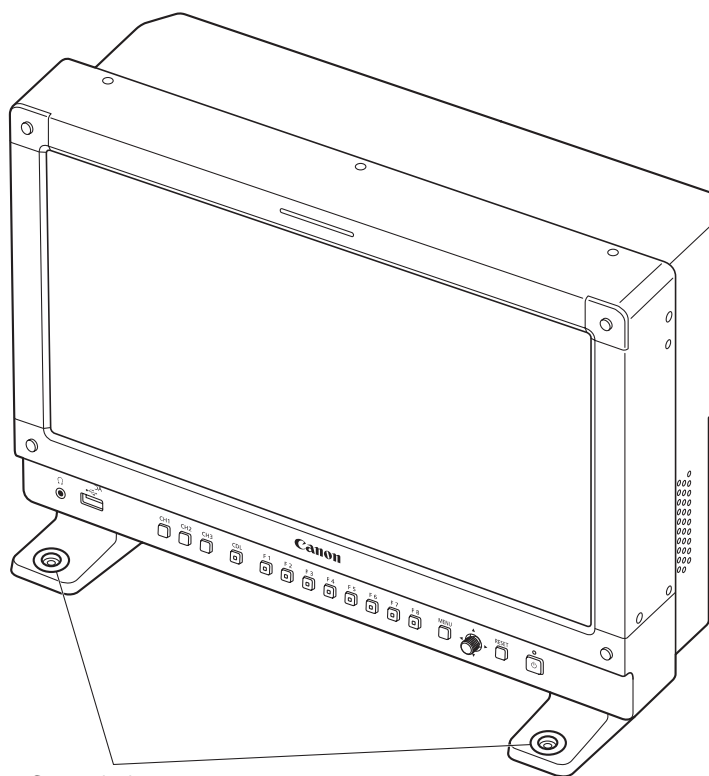

Screw hole
2-φ4.5

Mounting the Main Unit on a Stand or Wall

This main unit can be fitted to a stand* or to a wall mount bracket*. Remove the stands beforehand (📖 15).

* Commercially available.

! CAUTION

- For safety, make sure to perform this step with at least two people.
- When mounting the main unit on a wall, make sure the wall has sufficient strength. If necessary, apply reinforcement. Also, make sure to check the load capacity of the stand or wall mount bracket.
- When the video display is placed on a rack or display stand and ventilation around it is blocked by equipment placed above or below or in a surrounding area, the operating temperature may increase, causing a failure or overheating. In order to maintain the operating temperature condition of the video display (0 °C to 40 °C), make space of at least 1U (4.4 cm) above and below and at least 4 cm (1.6 in.) space from its back. Make sufficient space from peripheral equipment, secure vents, or install a ventilation fan.
- When installing the video display on a wall, make sufficient space from the wall so that cables are not squeezed or twisted.
- Avoid touching the screen during this step as it may damage it.
- Make sure that the main unit does not fall during installation/removal.

- 1 Attach a commercially available stand or wall mount bracket using the screw holes on the back or side face of the main unit.

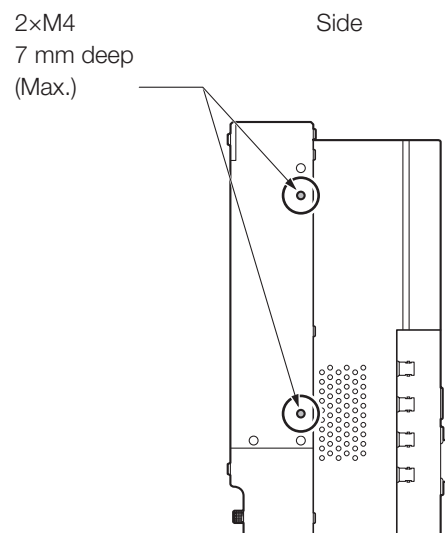
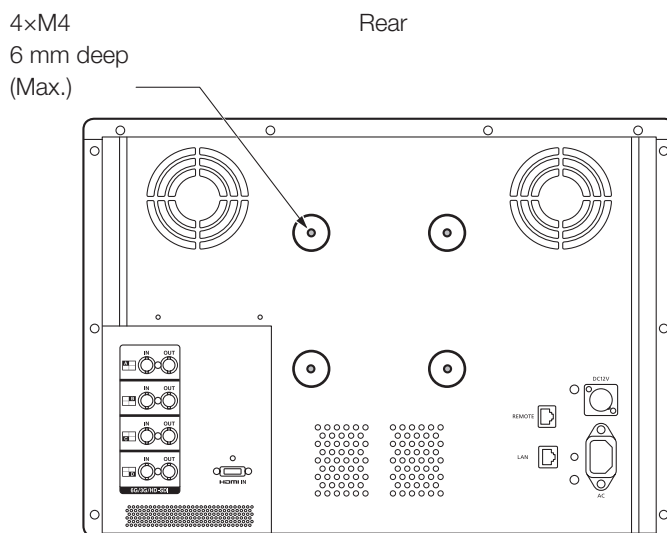

Same on the other side

Mounting the Main Unit on a 19 Inch Rack: RB-02 Rack Mount Bracket (sold separately)

This video display is compatible with a 19-inch rack mount (7U / complies with EIA standards). The video display can be attached to a 19-inch rack using the separately-sold RB-02 Rack Mount Bracket. The angle can be selected depending on how it is attached (-15/-6/6/15 degrees). Remove the carrying handle and stand before starting work (13, 15).

The Rack Mount Bracket is supplied with the SW-04 and SW-05 screws for attaching it. Please also see the instruction manual for the RB-02 Rack Mount Bracket.

! CAUTION

- For safety, make sure to perform this step with at least two people.
- When the video display is placed on a rack and ventilation around it is blocked by equipment placed above or below or in a surrounding area, the operating temperature may increase, causing a failure or overheating. In order to maintain the operating temperature condition of the video display (0 °C to 40 °C), make space of at least 1U (4.4 cm) above and below and at least 4 cm space from its back. Make sufficient space from peripheral equipment, secure vents, or install a ventilation fan.
- Ensure that you do not touch or damage the screen during this process.
- Make sure that the main unit does not fall during installation/removal.

1 Attaching a Rack Mount Bracket to the Video Display.

- Use the SW-04 screws in two locations each on the left and right.

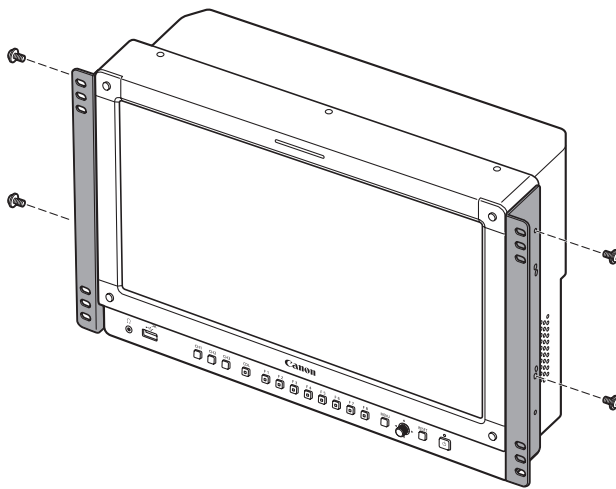

Rack Mount Bracket Screw
SW-04

Side view

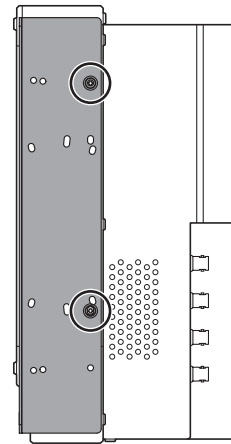

Same on the other side

- Screw positions for attaching the display at -15, -6, +6, or +15 degrees

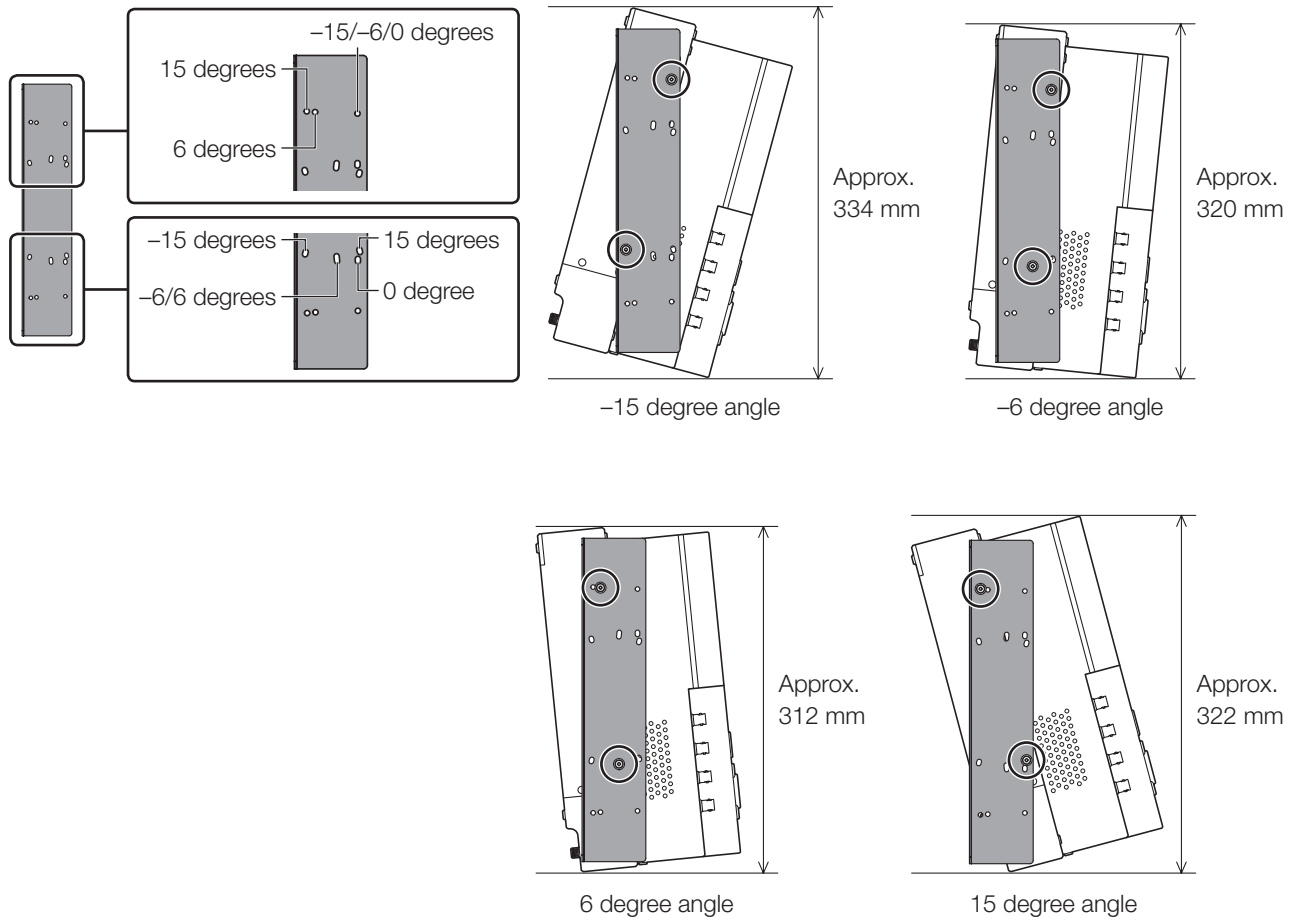

2 Attach the video display to the rack.

- Use the SW-05 screws in two locations each on the left and right.

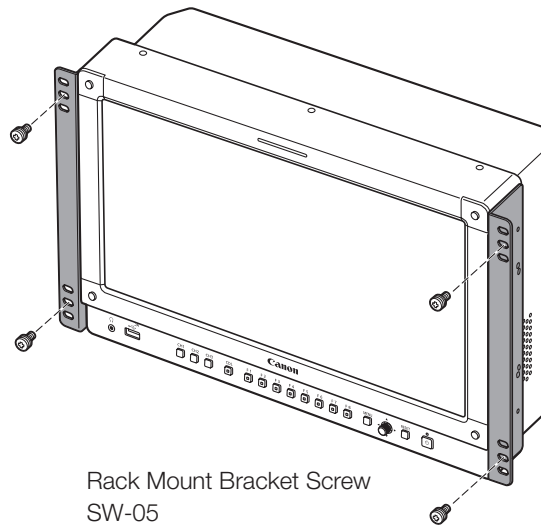

Rack Mount Bracket Screw
SW-05

Connecting the Main Unit to Input Devices

The video display has 6G/3G/HD-SDI and HDMI input terminals to connect input devices.

! CAUTION

- Check that the power of the video display and input devices is switched off before connecting.

SDI input signals

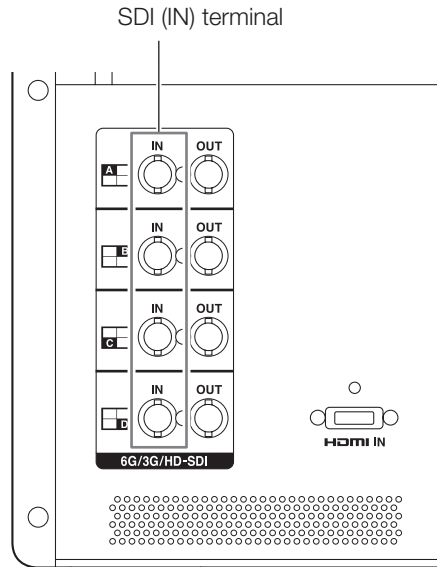

	Input signal		Input terminal	
Quad Link (Square Division)	3G/HD-SDI	Top left, Mapping signal	Input A	Single input system
		Top right, Mapping signal	Input B	
		Bottom left, Mapping signal	Input C	
		Bottom right, Mapping signal	Input D	
Quad Link ¹ (2 Sample Interleave)	3G-SDI	Link 1	Input A	Single input system
		Link 2	Input B	
		Link 3	Input C	
		Link 4	Input D	
Dual Link ¹	6G/3G-SDI	Link 1	Input A	Two input systems
		Link 2	Input B	
		Link 1	Input C	
		Link 2	Input D	
Single Link	6G/3G/HD-SDI	—	Input A/Input B/ Input C/Input D	Four input systems

¹ The signals are automatically switched when [Image Division] is set to [Automatic].

Reference

- The connection is tested using Canare Corp. BNC cable (multi) 4VS03A-5C.
- When 3G-SDI RAW signal frequency exceeds 30.00P, it becomes a dual connection.
- Each input terminal is compatible with through output. When signals are input from Input A, connect the cable to the SDI (OUT) terminal of Input A.

HDMI input signal

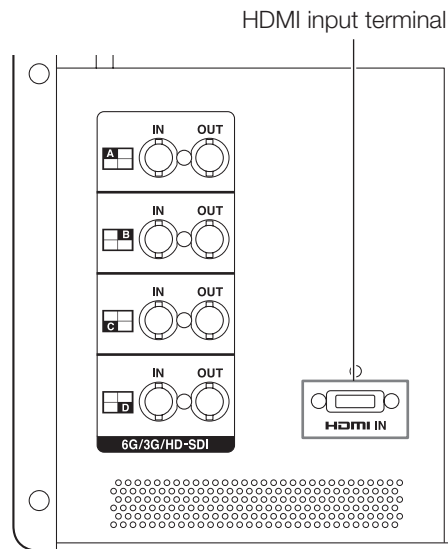

CAUTION

- Use a HDMI cable with the High Speed logo that complies with the HDMI standard. When a non-compliant HDMI standard cable is used, the video display may not work normally, for example a video becomes choppy or nothing is displayed.

Turning on the Power

22 Turning on the Power of the Main Unit

1 When using AC power supply

Plug the provided AC power cord HT-21 to the AC power supply input terminal at the rear.

- The video display goes into standby and the power indicator lights up in amber.

1 When using DC power supply (12 V DC)

Insert the DC power cord into the DC power supply input terminal at the rear.

- When connected normally, the video display goes into standby and the power indicator lights up in amber.
- DC power supply input terminal specifications are shown below.

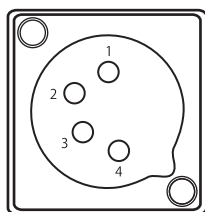

Pin No.	Signal
1	- (GND)
2	N.C.
3	N.C.
4	+ (12 V, max. 10 A)

2 Press the power supply button at the front.

- The power indicator lights green.

About the power indicator

Displays the status of the main unit. The brightness of the power indicator can be set from [Off] or [1 (dark)] to [5 (brightest)] (73). The power indicator will flash during firmware updates or when an error is detected even if it is set to [Off].

Off: when power supply is not connected

Green lit: when a power supply is connected and the power of the video display is on

Green flash: during calibration or firmware update

Amber lit: during standby (a power supply is connected and the power to the video display is off)

Amber flash: when error is detected

CAUTION

- Check the specifications of the DC power supply input terminal and use a power supply that is compatible with the video display. Using a power supply with incompatible voltage and polarity may cause fire or electric shock.
- Use a DC power cord with an allowable current of at least 10 A and a length of 2 m or less. If a DC power cord longer than 2 m is used, the video display may not work normally: for example, the video becomes choppy or nothing is displayed.
- Do not connect cables for audio devices or sound cables to the DC power supply input terminal, as it may cause damage to the display unit.

Note

- Warming-up is necessary to stabilize the brightness of the video display. Wait at least 10 minutes after turning on the power before using.
- When an AC power supply is connected during the use of DC power supply, the power source is switched to the AC power supply. When this happens, the power is turned off temporarily and then turned on again.

Attaching/detaching the HC-01 AC Power Cord Clamp (provided)

Attaching

Install the AC power cord clamp before connecting the AC power cord to the main unit.

- 1 Insert the AC power cord clamp connector into the cord clamp mounting hole (①).
- 2 Connect the AC power cord to the main unit (②).
- 3 Secure the AC power cord in place with the holder (③).
 - The holder should always be fastened in the position shown in the illustration of the AC power cord.
- 4 Press the holder against the main unit (④).
 - Make sure that there is no slack (**A**).
 - Pulling the holder lock lever in the direction of the arrow will allow you to adjust the holder position (⑤).

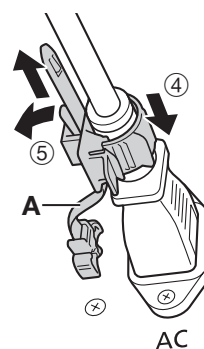
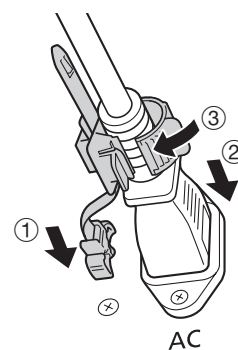

Detaching

- 1 Pull the holder lever in the direction of the arrow (⑥) and remove the AC power cord clamp from the AC power cord.
- 2 Press the knobs on the top and bottom and pull out the AC power cord clamp from the video display (⑦).

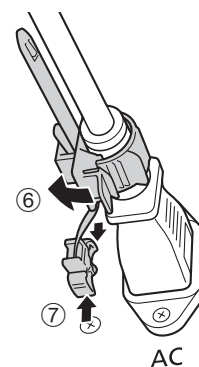

Operating the Video Display

24 Using buttons and jog dial on the video display, you can adjust image quality and configure settings for input signals. In addition, you can assign frequently used functions to the CH (Channel) and F (Function) buttons.

Basic operations to use the OSD menu

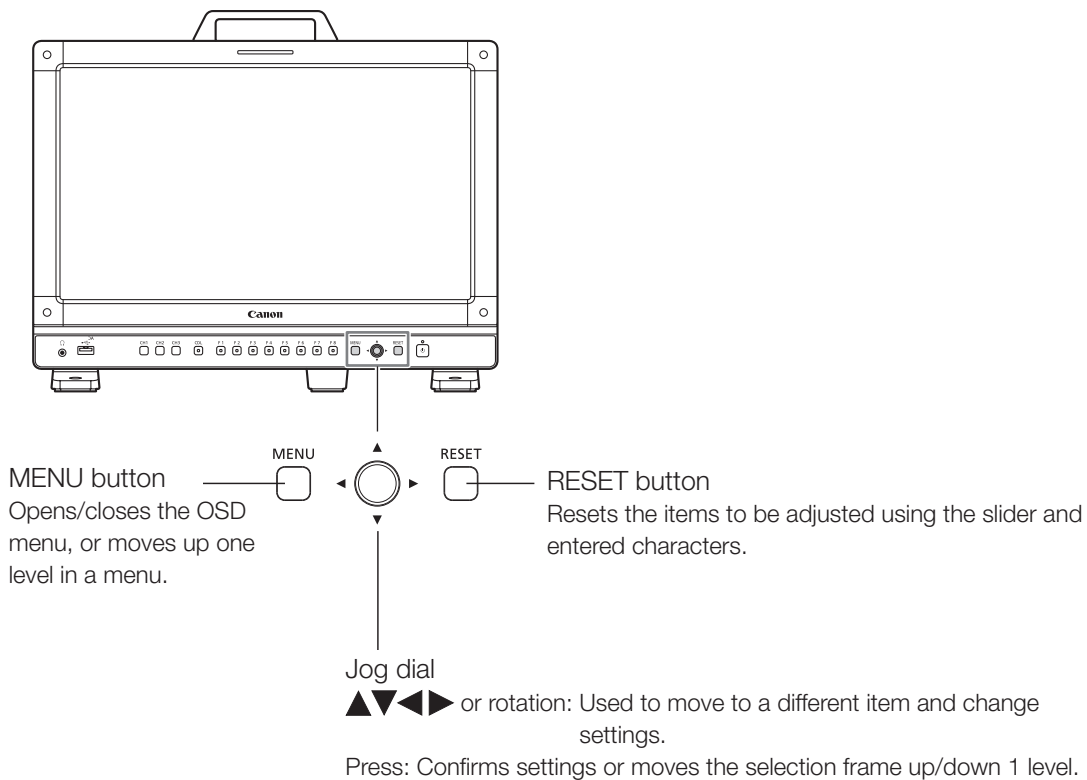

The video display settings are changed from the OSD menu.

- 1 Open the OSD menu.
 - Press the MENU button.
- 2 Select the Main Menu.
 - Select the Main Menu item using the jog dial and press it to determine the selection.
- 3 Select the Sub Menu.
 - Select the Sub Menu item using the jog dial and press it to determine the selection.

Main Menu	Sub Menu	Setting Options
	Adjustment	Target <input type="checkbox"/>
	Picture Mode	ITU-R BT.709
	Contrast	<input type="text"/> 1000
	Brightness	<input type="text"/> 0
	Chroma	<input type="text"/> 1000
	Sharpness	<input type="text"/> 0
	Backlight Control	Local Dimming Low
	Color Temperature	D65
	Color Gamut	ITU-R BT.709
	Gamma	2.2
	Color Range	Automatic (Limited 1)
	CDL/User LUT	CDL 3
	Detail Settings	
	Anchor Adjustment	
	Reset	

4 Select the setting to change.

- Select the setting to change using the jog dial and press it to determine the selection. You will be returned to the Sub Menu item selection screen.

5 Exit menu.

- Pressing the MENU button will return you to the Main Menu item selection screen. Pressing the MENU button again will close the menu screen.

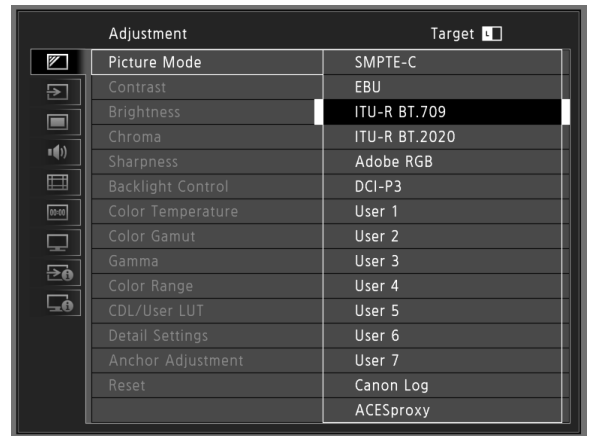

i Note

- To adjust image quality, warming-up is necessary to stabilize the brightness of the video display. Wait at least 10 minutes after turning on the power before using.
- The OSD menu and slider will disappear automatically if no operation is performed for approximately 1 minute. The F button will disappear automatically if no operation is performed for approximately 10 seconds.
- The settings that cannot be set, are grayed out.
- The following functions can be returned to their factory default settings by pressing the RESET button while adjusting the image quality.

- [Contrast], [Brightness], [Chroma], [Sharpness], [Power], [Saturation], [Offset], [Slope]

When [Picture Mode] [User 1] to [User 7]: When executing calibration, pressing the RESET button while adjusting the image quality will return you to the settings after calibration.

Adjusting Image Quality While Viewing the Entire Image

You can adjust the OSD menu to display as a slider at the bottom of the screen. This allows for the image quality to be adjusted whilst it is displayed on the screen.

- 1 Press the jog dial when the selection frame is on setting options.
 - A slider appears at the bottom of the screen.
- 2 Make adjustments using the jog dial with using the slider as guide.
- 3 When adjustments are completed, press the jog dial.
 - The screen returns to the original OSD menu.

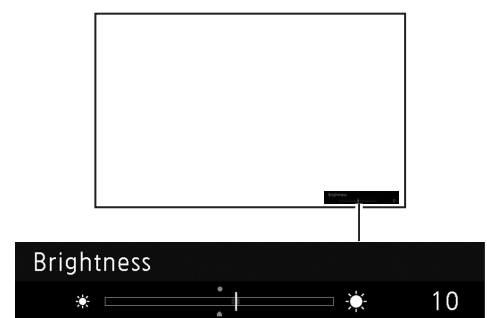

Color temperature detailed settings (gain, bias)

You can adjust RGB all at once or individually when the screens for adjusting [Gain] or [Bias] are displayed.

- 1 Open the [Color Temperature] menu.
[MENU] ➤ [Adjustment] ➤ [Color Temperature]
 - [Gain R], [Gain G], [Gain B], [Bias R], [Bias G], and [Bias B] can be set individually using the jog dial (◀▶).
- 2 Select one.
 - The setting screen for [Gain] or [Bias] will be displayed.
- 3 Switch the guide in the upper right area of the slider screen using the jog dial (▲▼).
 - The indication changes to [RGB], [R], [G], and [B]. Selecting [RGB] will allow you to adjust RGB as a whole.
- 4 When adjustments are completed, press the jog dial.
 - The screen returns to the original OSD menu.

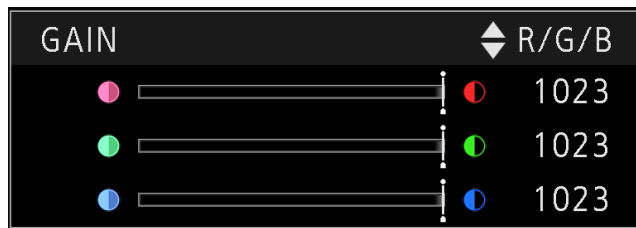

Color temperature detailed settings (xy values)

- 1 Open the [Color Temperature] menu.
[MENU] ➤ [Adjustment] ➤ [Color Temperature]
- 2 Select [Custom (xy)].
 - You can set [x] and [y] individually using the jog dial (◀▶).
- 3 Select either [x] or [y].
 - The color map is displayed.
- 4 Adjust [x] with the ◀▶ and [y] with ▲▼.
 - The adjusted value is indicated by the "○" mark on the color map.
- 5 When adjustments are completed, press the jog dial.
 - The screen returns to the original OSD menu.

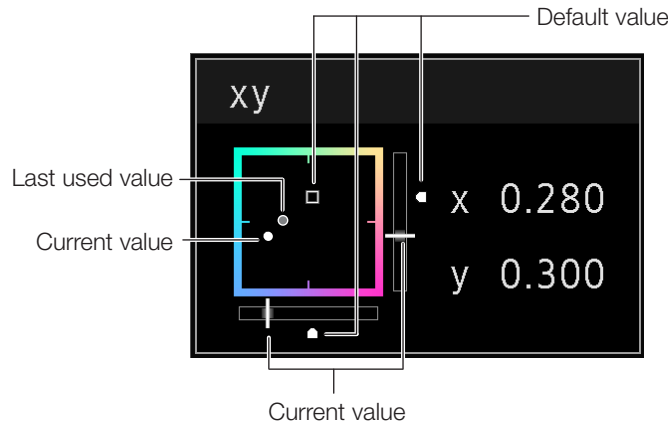

Temporarily Saving Parameters (Anchor Point Setting)

You can temporarily save parameters for [Contrast], [Brightness], [Chroma], and [Sharpness]. See [44](#) for setting anchor points during CDL adjustment.

1 Open the [Anchor Adjustment] menu.

[MENU] ➤ [Adjustment] ➤ [Anchor Adjustment]

2 Press the jog dial, and when the confirmation screen appears, select [OK].

- The parameter is saved and the anchor point is set.

3 Adjust the image quality again and press the RESET button on the video display.

- Returns you to the anchor point for each function.

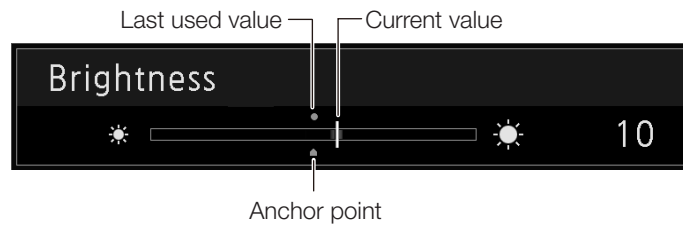

i Note

- Executing [Adjustment] ➤ [Reset] or [System Settings] ➤ [Reset All Settings] resets saved anchor points and the settings return to their factory default values.
- When calibration is executed, the values are saved as anchor points.

Enlarging the display (Zoom function) ([57](#))

The zoom display position can be adjusted, and the zoom magnification (2x, 4x, 8x) can be selected.

1 Open the [Zoom] menu.

[MENU] ➤ [Display Settings] ➤ [Zoom]

2 Select [Zoom Preset] using the jog dial.

- Select a preset zoom display.

3 Select [Position] using the jog dial.

- The zoom adjustment screen is displayed.
 - To move the display position: Move the jog dial (▲▼◀▶ or rotation).
 - To return to the center: Press the RESET button.

4 When adjustments are completed, press the jog dial.

- The screen returns to the original OSD menu.

Zoom 2 [x4]

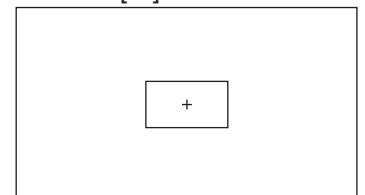

i Note

- When magnifying the image and the OSD menu is not being displayed, you can set the magnification ratio by pressing the jog dial.

Adjusting image quality for each screen in two screen display (📖 53)

In Multi View (Dual) display, image quality settings can be changed on both displayed screens.



1 Open the [Select Input Signal] menu.

[MENU] ➤ [Channel Settings] ➤ [Select Input Signal]

- Select [Dual Input A,B] or [Dual Input C,D], and then press the jog dial to confirm the setting.

2 Open the [Image Division] menu.

[MENU] ➤ [Channel Settings] ➤ [Image Division]

- Select [Multi View (Dual)], and then press the jog dial to confirm the setting. The screen changes to two screen display.
- When selecting [Adjustment] menu, the currently selected screen is identified by L or R (Left or Right) being displayed on the OSD menu screen.

3 Select a different [Picture Mode] for the left and right screens.

- Select [Picture Mode] in the screen on the left: [Channel Settings] ➤ [Picture Mode]
- Select [Picture Mode] in the screen on the right: [Channel Settings] ➤ [Picture Mode R]

4 Adjusting the image quality.

5 When adjustments are completed, press the jog dial.

- The screen returns to the original OSD menu.

Switching the target screen

- When the OSD menu is open:
 - In the [Adjustment] main menu, press the jog dial's ◀ button.
 - In the [Adjustment] main or sub menu, press the CH1 button.
- When the OSD menu is not being displayed: Move the jog dial (◀▶).

i Note

- In the [Multi View (Dual)] display, the HDR (High Dynamic Range) and SDR (Standard Dynamic Range) displays can be tested side by side. ([Adjustment] ➤ [Detail Settings] ➤ [HDR/SDR View] 📖 46)

Changing the screen display area (for video of 4096x2160)

When a video signal of 4096x2160 is input, the left and right parts will be trimmed for display.

1 Press the jog dial (◀▶) while the OSD menu is closed.

- Shifts to the left or right.

Performing calibrations (📖 46)

You can perform calibration using an external sensor, without using a computer.

The supported external sensors are Konika Minolta Display Color Analyzers CA-310 and CA-210. Be sure to also read the instruction manual of the CA-310 and CA-210.

1 Connect the display color analyzer to the USB port of the main unit.

2 Select [User 1] to [User 7] and then open the [Calibration] menu.

- ① **MENU** ➤ [Adjustment] ➤ [Picture Mode] ➤ [User 1] to [User 7]
- ② **MENU** ➤ [Adjustment] ➤ [Detail Settings] ➤ [Calibration]
- Set each target value.

3 Press the jog dial and select [Start].

- Please follow the information indicated on the screen.

4 Initialize the sensor.

- Set the mode dial of the Universal Measuring Probe to [0-CAL].
- Press the jog dial of the video display, select [OK], and execute initialization.

5 Place the universal measuring probe pointing at the center of the video display.

- Set the mode dial of the universal measuring probe to [MEAS] and place the probe as shown below according to the displayed content. Press the jog dial of the video display, select [OK], and execute calibration.

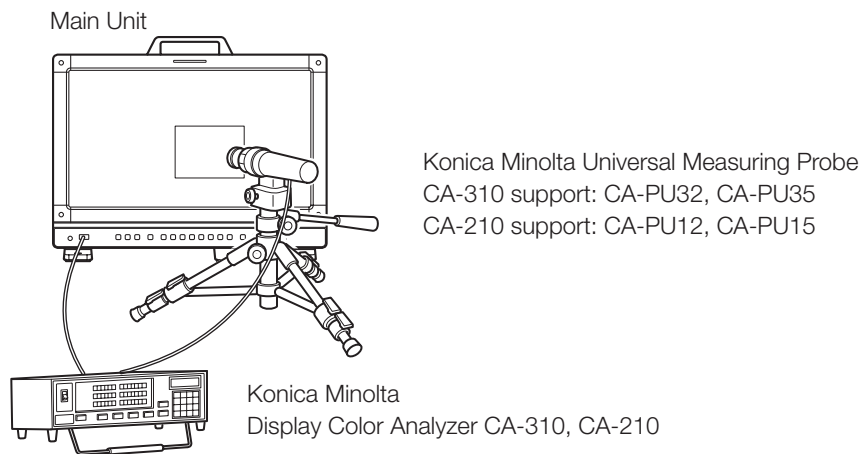

6 Finish calibration.

- When the message [Calibration is completed]. is displayed, press the jog dial and select [OK].
- If the message [Calibration error.] is displayed.
Calibration has been terminated due to an error. The main unit returns to the state before calibration. (99)
- To cancel calibration
Press the jog dial during calibration and select [Cancel]. The main unit returns to the state before calibration.

i Note

- Perform matrix calibration of the display color analyzer prior to calibration. If calibration is performed without performing matrix calibration, an error may occur. Refer to the CA-310 and CA-210 instruction manual for the detail operation.
- Warming-up is necessary to stabilize the brightness of the video display. Wait at least 10 minutes after turning on the power before calibration.
- Perform calibration in a dark room so that no external light enters the sensor. If external light enters the sensor, low brightness characteristics cannot be calibrated correctly.
- Due to the characteristic of LCD panel and individual difference of CA-310 and CA-210, the calibration results may differ.

Export/Import

You can export/import LUT and CDL parameters as well as main menu settings.

30 LUT Import (📖45)

- 1 Insert a USB memory stick into the USB port of the main unit.
- 2 Open the [LUT Import] menu.
 [MENU] ➡ [Adjustment] ➡ [Detail Settings] ➡ [LUT Import]
- 3 Select the file using the jog dial.
 - In the [Filename] field, search and display a file with extension [.clut] in the root folder.
- 4 Select the LUT type using the jog dial.
 - Select the LUT type by using [User LUT], [Gamma LUT] or [Gamut LUT].
 - Refer to the "Concept Drawing of Display Image Processing and LUT". Or, also refer to the "User LUT Creation Guide" on the Canon website.
- 5 Select [Select LUT] using the jog dial.
 - Selects User LUT 1-8/Gamma LUT 1-8/Gamut LUT 1-8.
- 6 Select the standard color gamut using the jog dial.
 - Select the color gamut used when creating the LUT (when [Gamut LUT] under [LUT Type] is selected).
- 7 Select [Execute] using the jog dial.
 - When the confirmation screen appears, select [OK]. Import starts.

i Note

- The LUT file is proprietary to Canon Video Display. Refer to the Canon website for the file format and how to create.
- Up to 1000 LUT import files are recognized.
- You can delete the imported LUT. You can specify the name of LUT (📖45).

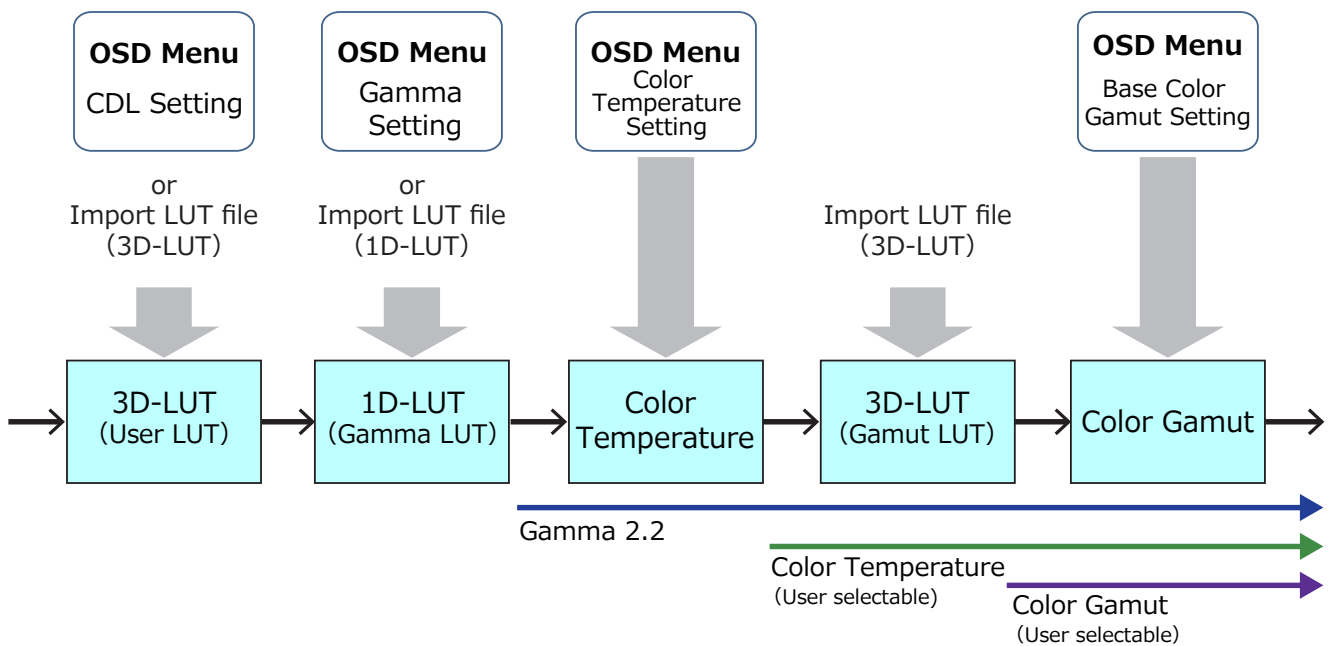

Concept Drawing of Display Image Processing and LUT

Export/Import Main Menu Settings (📖 74)

- 1 Open the [Export/Import] menu.
 [MENU] ➤ [System Settings] ➤ [Export/Import]
- 2 Select [Export] or [Import] using the jog dial.

Exporting

- ① Select [Target] from [USB] or [User 1] to [User 3].
 Export [USB] to the USB memory and [User 1] to [User 3] to the built-in memory of the main unit.
- ② Select [Filename] when [USB] is selected.
 Factory default is [dinfo_dpv1710.dat]. You can change the name of the file to be exported to the USB memory within 16 one-byte characters including alphabetical characters, numbers, and symbols.

Importing

- ① Select [Target] from [USB] or [User 1] to [User 3].
 Specify the destination to save the file to be imported.
 - ② Select [Filename] when [USB] is selected.
 - ③ In [Settings], select [All] or Main Menu name.
- 3 Select [Execute] using the jog dial.
 - When the confirmation screen appears, select [OK]. Export/Import starts.

i Note

- After export to [User 1] to [User 3], you can select the configurations at startup from [User 1] to [User 3] in [Power on Setting] in [System Settings] (📖 75).

Exporting/Importing CDL Parameters (📖 44)

- 1 Open the [Type] menu.
 [MENU] ➤ [Adjustment] ➤ [CDL/User LUT] ➤ [Type]
- 2 Select [CDL] using the jog dial.
- 3 Select [Detail Settings] ➤ [CDL Export] or [CDL Import].

Exporting

- ① Select [CDL Preset].
- ② Select a file format [.ccc] or [.cdl].

Importing

- ① Select [Filename].
 - ② Select [CDL Preset].
- 4 Select [Execute] using the jog dial.
 - When the confirmation screen appears, select [OK]. Export/Import starts.

i Note

- The exported file is automatically saved under the name "YYYYMMDDhhmmss_Preset name.ccc (cdl)".
- Up to 1000 CDL import files are recognized.

Set Date/Time (📖 72)

This section describes how to set the Date/Time. The Date/Time of this video display will be reset if the power cord is not connected for about 20 days.

- 1 Open the [Date/Time] menu.
 - ▶ [MENU] ▶ [System Settings] ▶ [Date/Time]
 - A screen to input the Date/Time appears.
- 2 Set the Date/Time using the jog dial.
 - The selection frame moves and numbers change as you operate the jog dial. Repeat until you complete setting the year, month, date, hour, and minute.
- 3 Press the jog dial when you are finished.
 - The selection frame moves to [OK].
- 4 Check the content and press the jog dial to confirm the settings.

✔ Reference

- When selecting [Cancel] or pressing MENU button before selecting [OK], the settings will be reset and the previous screen will be displayed.

Inputting Characters

This section describes how to input the characters. Use this function to specify a channel name, a display name, or filename.

- 1 When the character input screen is displayed, use the jog dial (◀▶) to select the area you wish to input.
- 2 Select characters using the jog dial (▲▼ or rotation).
 - The following characters can be selected: Press ▲▼ buttons to display them one by one. You can input up to 16 characters.

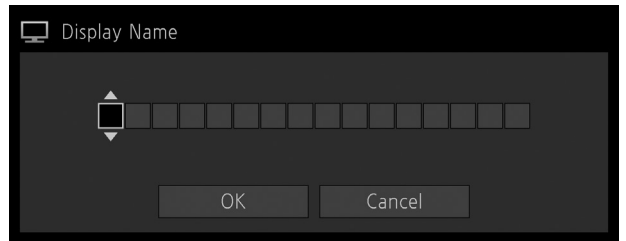

Alphanumeric characters: A to Z, a to z, 0 to 9
 Symbols: , . : ; ' ` - + / = % & ! ? # _ | \$ ^ ~ @ { } [] < > () space

- Some characters cannot be used for a filename. In this case, they are automatically skipped.
- 3 Repeat steps 1 and 2 until the desired text has been inputted.
 - 4 Press the jog dial when you are finished.
 - The selection frame moves to [OK].
 - 5 Check the content and press the jog dial to confirm the settings.

✔ Reference

- When selecting [Cancel] or pressing MENU button before selecting [OK], the settings will be reset and the previous screen will be displayed.
- To erase the character in the selection frame, press the RESET button of the video display.

Using the Function (F) Buttons

You can assign functions to the F buttons on the video display to execute them instantly. You can assign different functions on F buttons in the normal and CDL modes respectively.

- 1 Open the [Display Function] or [Display Function (CDL)] menu.
 [MENU] ➤ [System Settings] ➤ [Function/Channel Button] ➤ [Display Function] or [Display Function (CDL)]
 - The button selection screen will be displayed.
- 2 Select the name of the button using the jog dial and press the jog dial to determine the selection.
- 3 Select the function to assign using the jog dial.
 - See [Display Function] or [Display Function (CDL)] (📖 76) for the available functions.
- 4 Press the jog dial to determine the selection.
 - The setting is confirmed.

The following content is assigned to function buttons on the video display by factory default.

F button	Normal mode	CDL mode
F1	Contrast	CDL R
F2	Brightness	CDL G
F3	Time Code	CDL B
F4	WFM/VEC	CDL Power
F5	Audio Level Meter	CDL Offset
F6	Zoom Preset	CDL Slope
F7	Hide OSD	CDL Saturation
F8	False Color	CDL/User LUT Bypass



Reference

- You can check the function assigned to the F buttons of the main unit.
 Open the [MENU] ➤ [Function Settings] ➤ [Various Function] ➤ [Function Guide] menu and select [On]. Pressing the jog dial while OSD is not showing will display the list of functions (📖 68).

Using the Channel (CH) Button

You can assign channels (various settings related to input signal) to the CH buttons on the video display and switch channels instantly.

- 1 Open the [Display Channel] menu.
 [MENU] ➤ [System Settings] ➤ [Function/Channel Button] ➤ [Display Channel]
 - The button selection screen will be displayed.
- 2 Select the name of the button using the jog dial and press the jog dial to determine the selection.
- 3 Select the channel to assign using the jog dial.
 - See [Channel Settings] (📖 53) for the configurable settings.

4 Press the jog dial to determine the selection.

- The setting is confirmed.

The following content is assigned to channel buttons on the video display and to each channel by factory default.

CH	CH1	CH2	CH3	CH4 to CH20
Input Configuration	6G/3G/HD-SDI	HDMI	3G-SDI RAW	— (Not set)
Select Input Signal	Automatic	Automatic	Automatic	Automatic
Image Division	Automatic	Automatic	Automatic	Automatic
Format	Automatic	Automatic	Automatic	Automatic
Internal Sync	Off	Off	Off	Off
Channel Name	(Blank)	(Blank)	(Blank)	(Blank)
Picture Mode	ITU-R BT.709	ITU-R BT.709	Canon Log	ITU-R BT.709
Picture Mode R	ITU-R BT.709	ITU-R BT.709	Canon Log	ITU-R BT.709
Audio Input	Input A	Input A	Input A	Input A
Marker/TC/WFM/VEC Input	Input A	Input A	Input A	Input A
Picture Function Target	Left and Right	Left and Right	Left and Right	Left and Right
Separator	Off	Off	Off	Off

Checking Signal Information and Status of the Main Unit

The video display is equipped with a banner display function.

1 Press the jog dial when the OSD menu is closed.

- The channel name, signal information, and status of the main unit will be displayed in the banner. It will automatically disappear after 6 seconds.

i Note

- For more detailed signal information, please refer to the section on [Signal Information] (178).
- The [Detecting sync.] banner will continue to appear until the input signal is synchronized.

Operating the video display using an external device REMOTE terminal(GPI)

You can operate the video display using an external device connected to the REMOTE terminal and execute the functions registered in each pin. Remote operation is possible only when the video display is turned on.

Pin layout for REMOTE terminal

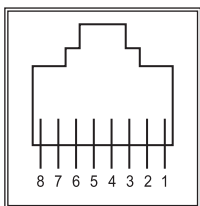

Pin No.	Signal	Factory default
1	Pin1	CH1
2	Pin2	CH2
3	Pin3	CH3
4	Pin4	Time Code
5	Pin5	Tally Green
6	Pin6	Tally Red
7	Pin7	Power On
8	Pin8 (GND)	—

- 1 Connect an external control device to the REMOTE terminal.
- 2 Open the [Remote(GPI)] menu.
 - [MENU] ➤ [System Settings] ➤ [Network/Remote(GPI) Settings] ➤ [Remote(GPI)]
 - The pin selection screen will be displayed.
- 3 Select a pin number using the jog dial and press it to determine the selection.
- 4 Select the function to assign using the jog dial.
 - Please see [Remote(GPI)] (73) for settable functions.
- 5 Press the jog dial to determine the selection.
 - The setting is confirmed.

Operating the video display using an external device LAN terminal

The video display supports Television Systems Ltd.'s "TSL UMD Protocol Ver. 5.0". You can operate the video display using an external device connected to the LAN terminal and display characters and tally lights on the screen. There are two tally lights, on the left and right. Up to 16 characters can be entered. The following characters can be entered.

Alphanumeric characters: A to Z, a to z, 0 to 9

Symbols: , . : ; ' ` - + / = % & ! ? # _ | \$ ^ ~ @ { } [] < > () and spaces

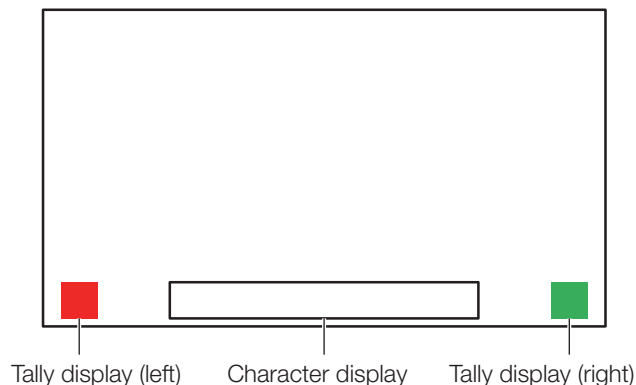

- 1 Connect an external control device to the LAN terminal.
- 2 Set [SCREEN] and [INDEX] to [0x0000] in the TSL Protocol settings.
- 3 Open the [In Monitor Display] menu.
 - [MENU] ➤ [System Settings] ➤ [Network/Remote(GPI) Settings] ➤ [In Monitor Display]
- 4 Select [Control] ➤ [On] using the jog dial.
 - This will allow operation from an external control device, and display characters and tally lights.
- 5 Select [Position] ➤ [Top] or [Bottom] using the jog dial.
 - This sets the position where characters and tally lights will be displayed.

i Note

- When [Multi View (Dual)] or [Multi View (Quad)] is displayed, set the [INDEX] setting to from [0x0001] to [0x0004].
- The port number for the controlling is fixed at "45000".

OSD Menu

36 OSD Menu Index

Adjustment (📖 40)

- Picture Mode
- Contrast
- Brightness
- Chroma
- Sharpness
- Backlight Control
- Color Temperature
- Color Gamut
- Gamma
 - HDR Range
- Color Range
- Input Transform
- Output Transform
- Output Transform Surround
- CDL/User LUT
 - Type
 - CDL Preset
 - User LUT
 - Power
 - Saturation
 - Offset
 - Slope

- CDL/User LUT Bypass
- Detail Settings
 - CDL Export
 - CDL Import
 - CDL Preset Name
- Anchor CDL
- Reset CDL
- Detail Settings
 - LUT Import
 - LUT Name
 - LUT Delete
 - YCbCr Color Matrix
 - 2020 Constant Luminance
 - 2020 Gamut Mapping
 - Hybrid Log-Gamma System
 - HDR/SDR View
 - Calibration
 - Copy Picture Mode
 - Picture Mode Name
- Anchor Adjustment
- Reset

Channel Settings (📖 53)

- Select Channel
- Input Configuration
- Select Input Signal
- Image Division
- Format
- Internal Sync
- Channel Name
- Picture Mode
- Picture Mode R
- Audio Input
- Marker/TC/WFM/VEC Input
- Picture Function Target
- Separator

Display Settings (📖 56)

- Screen Scaling
- Scaling Method
- Zoom
 - Zoom Preset
 - Magnification
 - Position
- Frame Hold
- I/PsF
- PsF
- I/P Conversion
- Film Cadence

37

Audio Settings (📖 59)

- SDI Group
- CH L/R (SDI)
- CH L/R (HDMI)
- Volume
- Audio Switch

Marker Settings (📖 60)

- Marker Preset
- Aspect Marker
 - Enable
 - Mask
 - Aspect Ratio
 - Line
 - Line Width
 - Line Color
 - Line Brightness
 - H Position
 - V Position
- Safety Zone Marker 1, 2
 - Enable
 - Aspect Ratio
 - Area Size
 - Rate (%)
 - Width (dot)
 - Height (dot)
 - Shape
 - Line Width
 - Line Color
 - Line Brightness
 - H Position
 - V Position
- Area Marker
 - Enable
 - H Position
 - V Position
 - Width (dot)
 - Height (dot)
 - Mask
 - Line
 - Line Width
 - Line Color
 - Line Brightness
- Center Marker
 - Enable
 - Size
 - Line Width
 - Line Color
 - Line Brightness
- Grid Marker
 - Enable
 - Distance
 - Line Width
 - Line Color
 - Line Brightness

Function Settings (📖 65)

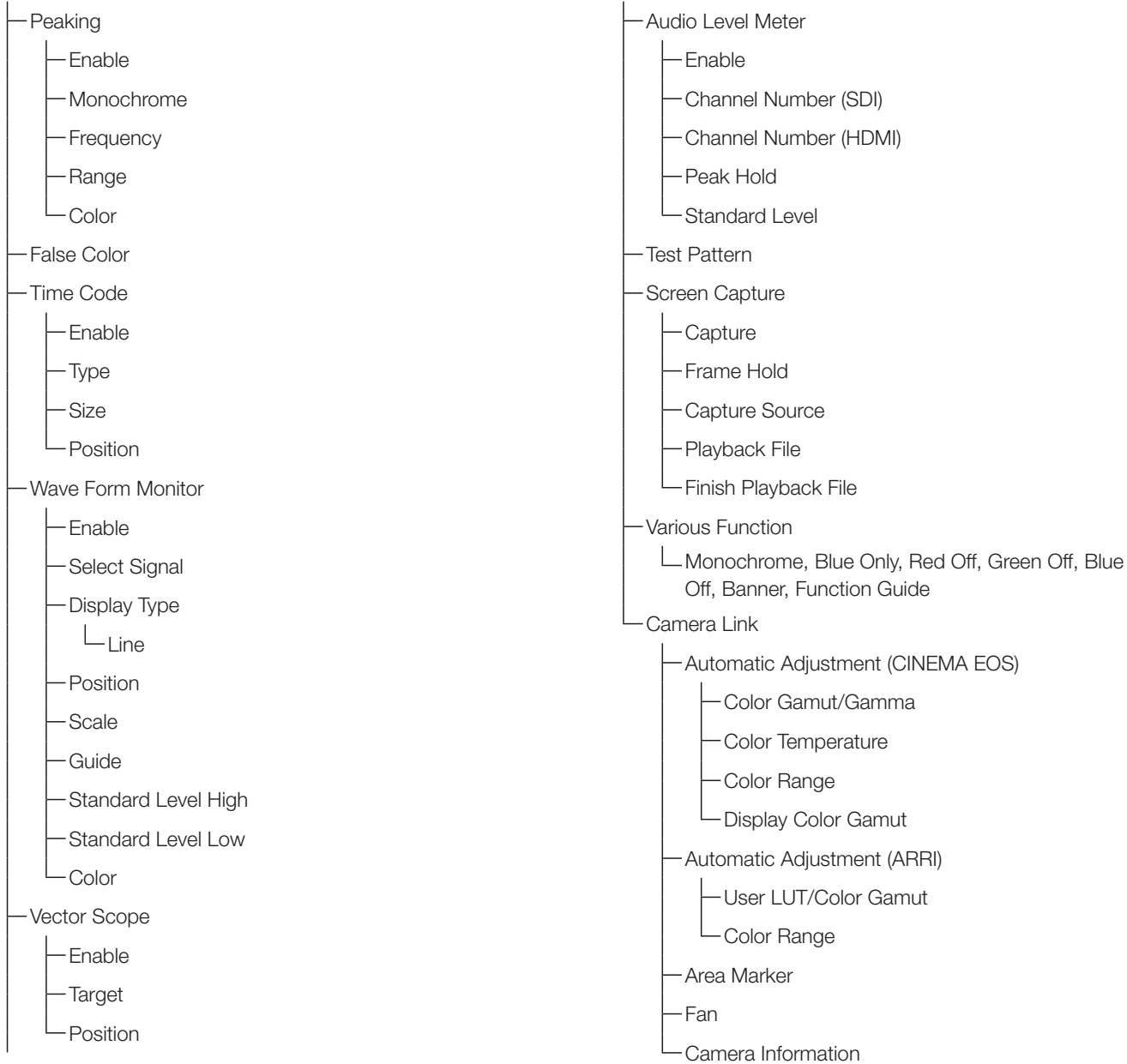

System Settings (📖72)

- Function/Channel Button
 - Display Function
 - Display Function (CDL)
 - Display Channel
- Language
- Date/Time
- Network/Remote(GPI) Settings
 - Network
 - In Monitor Display
 - Remote(GPI)
- Display Name
- Power Indicator Brightness
- Display Button LED
- Fan Settings
 - Fan Control
 - Fan Stop
- Compatible Settings
 - HDMI
- Protect Settings
 - Password
 - Protect Target
 - Protect
- Firmware Update
- Export/Import
 - Export
 - Import
- Power on Setting
- Reset All Settings

Signal Information (📖78)
-----**System Information** (📖78)

Adjustment

This menu is used to adjust the image quality and perform calibration. The factory defaults differ according to the [Picture Mode] setting. (📖51)

40

Sub Menu	Setting Options (Bold: factory default)	
Picture Mode	SMPTE-C EBU ITU-R BT.709 ITU-R BT.2020 Adobe RGB DCI-P3 User 1 to User 7 Canon Log ACESproxy	Select a preset mode. [SMPTE-C], [EBU], [ITU-R BT.709], [ITU-R BT.2020], [Adobe RGB], [DCI-P3]: Mode set to the brightness, color temperature, gamma, and color gamut of the three primary colors chromaticity points of each standard. [User 1] to [User 7]: This mode allows you to set each item in [Adjustment] individually. You can change the mode name within 16 one-byte characters including alphabetical characters, numbers, and symbols. [Canon Log]: Canon Log is the ideal mode for displaying images captured with CINEMA EOS SYSTEM cameras. Displays Canon Log video without having to import Viewing LUT. [ACESproxy]: A mode to display ACESproxy videos in optimum gamma and color gamut.
Contrast ¹	0 to 3000	Adjusts the white level of the image. (Increments of 1) When using DC power, the upper limit of the setting value is [1000] when [Backlight Control] is set to [Local Dimming Low/High].
Brightness	-500 to 500 (0)	Adjusts the black level of the image. (Increments of 1)
Chroma ²	0 to 2000 (1000)	Adjusts the color saturation of the image (color depth). (Increments of 1)
Sharpness	0 to 100 (0)	Adjusts the sharpness of the image. (Increments of 1)
Backlight Control ¹	Local Dimming High Local Dimming Low Off	Switches the backlight control method. [Local Dimming High, Low]: Local dimming technology controls the amount of light emitted by the backlight for each display area. The backlight of bright area is increased and the dark area is decreased according to the displayed content.
Color Temperature ³	D93, D65, D61, D60, D56, D50, DCI-P3 Custom (xy), Off • When a preset is selected Gain R/G/B: 0 to 1023 Bias R/G/B: -500 to 500 (0) • When Custom (xy) is selected x: 0.260 to 0.360 y: 0.260 to 0.360	Sets the color temperature. (📖26) [D93], [D65], [D61], [D60], [D56], [D50], [DCI-P3]: Select from preset color temperatures. [Gain R/G/B], [Bias R/G/B]: Adjusts the preset color temperature. (Increments of 1) [Custom (xy)]: Adjusts CIE x and y. (Increments of 0.001)

Sub Menu	Setting Options (Bold: factory default)	
Color Gamut ⁴	SMPTE-C EBU ITU-R BT.709 ITU-R BT.2020 Adobe RGB DCI-P3 Native Cinema Gamut to 709 Cinema Gamut to 2020 Cinema Gamut to DCI DCI-P3+ to 709 DCI-P3+ to DCI DCI-P3 to 709 ITU-R BT.2020 to 709 Gamut LUT 1 to Gamut LUT 8 ACESproxy	Sets the color range. When [Picture Mode] ► [User 1] to [User 7] or [Canon Log] [SMPTE-C], [EBU], [ITU-R BT.709], [ITU-R BT.2020], [Adobe RGB], [DCI-P3]: Color gamut compliant to each standard. [Native]: Color gamut that can be displayed by this video display. [Cinema Gamut to 709], [Cinema Gamut to 2020], [Cinema Gamut to DCI], [DCI-P3+ to 709], [DCI-P3+ to DCI], [DCI-P3 to 709], [ITU-R BT.2020 to 709]: Modes where the color gamut is converted to monitor Cinema Gamut, DCI-P3+, BT.2020, and DCI-P3 videos recorded by the CINEMA EOS SYSTEM cameras. [Gamut LUT 1] to [Gamut LUT 8]: Selects an external LUT. When [Picture Mode] ► [Canon Log] [ACESproxy]: Displays the color gamut of ACESproxy.
Gamma ⁵	1.0, 2.2, 2.35, 2.4, 2.6, ITU-R BT.1886 Canon Log Canon Log (HDR) Canon Log 2 Canon Log 2 (HDR) Canon Log 3 Canon Log 3 (HDR) SMPTE ST 2084 Hybrid Log-Gamma Y Hybrid Log-Gamma RGB Gamma LUT 1 to Gamma LUT 8 Off	Sets the Gamma (EOTF). [1.0], [2.2], [2.35], [2.4], [2.6], [ITU-R BT.1886], [Canon Log], [Canon Log 2], [Canon Log 3]: Select the preset gamma. [Canon Log (HDR)], [Canon Log 2 (HDR)], [Canon Log 3 (HDR)], [SMPTE ST 2084], [Hybrid Log-Gamma Y], [Hybrid Log-Gamma RGB]: Select the gamma for HDR display. [Gamma LUT 1] to [Gamma LUT 8]: Selects an external LUT. ❖ About [Hybrid Log-Gamma] This video display supports the following two methods. [Hybrid Log-Gamma Y]: This method processes the system gamma for the Y signal. [Hybrid Log-Gamma RGB]: This method processes the system gamma for the RGB signal.

Sub Menu	Setting Options (Bold: factory default)	
HDR Range	Sets the display method when Gamma for HDR display is selected.	
Canon Log (HDR)	100 to 800	Sets the [Canon Log] dynamic range to be displayed, from 0 to 800%. (in 100 increments)
Canon Log 2 (HDR)	100 to 1600	Sets the [Canon Log 2] dynamic range to be displayed, from 0 to 1600%. (in 100 increments)
Canon Log 3 (HDR)	100 to 1600	Sets the [Canon Log 3] dynamic range to be displayed, from 0 to 1600%. (in 100 increments)
SMPTE ST 2084	100 to 10000 (1000)	Sets the [SMPTE ST 2084] dynamic range to be displayed, from 0.005 to 10,000 nit. (in 100 increments)
Hybrid Log-Gamma Y	100 to 1000/2000/4000	Sets how far to display the [Hybrid Log-Gamma] dynamic range. (100 to 1000 in increments of 100) The upper limit value will change to match the settings of [Hybrid Log-Gamma System]. (46)
Hybrid Log-Gamma RGB	100 to 1000/2000	

❖ Setting procedures

The procedures below use Canon Log (HDR) as an example.





When the maximum value (800) is specified, the 800% dynamic range of Canon Log is assigned to the dynamic range of the video display. Although the brightness in appearance lowers, you can check the dynamic range included in video signals.

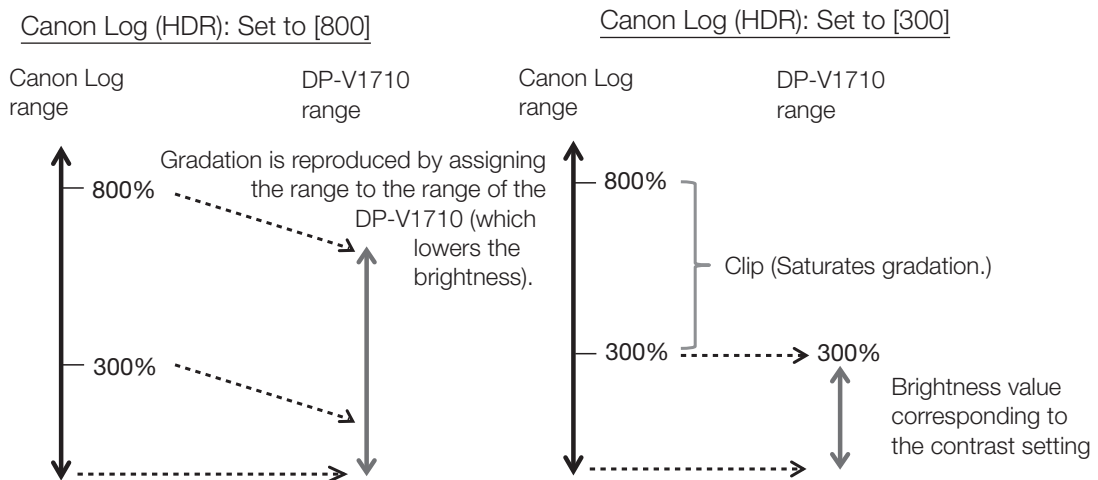

When [300] is specified, the part exceeding 300% of Canon Log is clipped (gradation is saturated) and the part up to 300% is assigned to the dynamic range of the video display.



The brightness of the video display corresponds to the value set for Contrast.





**Canon Log 800% signal
(Contrast: [3000])**



Sub Menu	Setting Options (Bold: factory default)	
Input Transform	Automatic Off	When [Picture Mode] or [Color Gamut]  [ACESproxy] Sets whether to apply ACES Input Transform to the [3G-SDI RAW] signal ( 53). Displayed instead of [Gamma] or [Color Gamut]. [Automatic]: Applied automatically. [Off]: Not applied.
Output Transform	ITU-R BT.709 ITU-R BT.2020 DCI-P3	When [Picture Mode] or [Color Gamut]  [ACESproxy] Displayed instead of [Gamma] or [Color Gamut]. [ITU-R BT.709], [ITU-R BT.2020], [DCI-P3]: ACESproxy is converted into respective mode.
Output Transform Surround	Dim Surround Dark Surround	When [Picture Mode] or [Color Gamut]  [ACESproxy] Displayed instead of [Gamma] or [Color Gamut]. [Dim Surround]: Enables Dim Surround process specified by ACESproxy. [Dark Surround]: Enables Dark Surround process specified by ACESproxy.
Color Range ⁶	Automatic Full (0-255) Limited 1 (16-235) Limited 2 (16-255)	Sets the quantization range. [Automatic]: Sets the range based on signal information automatically. [Full (0-255)]: Black level: 0 White level: 1023 (10-bit)/4095 (12-bit) [Limited 1 (16-235)]: Limits the black and white range. Black level: 64 (10-bit)/256 (12-bit) White level: 940 (10-bit)/3760 (12-bit) [Limited 2 (16-255)]: Limits the black range. Black level: 64 (10-bit)/256 (12-bit) White level: 1023 (10-bit)/4095 (12-bit)

Sub Menu	Setting Options (Bold: factory default)	
CDL/User LUT ⁷	Configures settings for CDL or User LUT.	
Type	CDL User LUT Off	Select the type.
When [Type]  [CDL]		
CDL Preset	CDL 1 to CDL 15	Selects a preset of the CDL.
Power	0.50 to 4.00 (1.00)	Adjusts the Gamma of the image. (0.01 increments)
Saturation	0.000 to 2.000 (1.000)	Adjusts the color saturation of the image. (0.001 increments)
Offset	-1.000 to 1.000 (0.000)	Adjusts the black level of the image. (0.001 increments)
Slope	0.000 to 2.000 (1.000)	Adjusts the white level of the image. (0.001 increments)
CDL/User LUT Bypass	On, Off	When set to [On], you can temporarily disable the CDL adjustment result and return to previously set image quality.
Detail Settings		
CDL Export		Exports CDL parameters.
CDL Preset	CDL 1 to CDL 15 All	
File Type	CCC CDL	
Execute		
CDL Import		Imports CDL parameters.
Filename		
CDL Preset	CDL 1 to CDL 15 All	
Execute		
CDL Preset Name		You can specify the name of preset mode within 16 one-byte characters including alphabetical characters, numbers, and symbols.
Anchor CDL		You can temporarily save parameters for [Power], [Saturation], [Offset], and [Slope] and recover the values. (anchor point setting)
Reset CDL		Resets CDL parameters.
When [Type]  [User LUT]		
User LUT	User LUT 1 to User LUT 8 ARRI LUT 709 ARRI LUT 2020	Sets preset of the User LUT or the LUT for ARRI cinema cameras.
CDL/User LUT Bypass	On, Off	When set to [On], you can return to the image quality before user LUT was applied.

Sub Menu	Setting Options (Bold: factory default)	
Detail Settings 	Sets details for Picture Mode.	
LUT Import	You can import LUT. File names that can be imported can be up to 48 one-byte characters, including alphabetical characters, numbers, and symbols (including file extensions).	
Filename		Select a filename.
LUT Type	User LUT Gamma LUT Gamut LUT	Select the LUT type.
Select LUT	User LUT 1-8 Gamma LUT 1-8 Gamut LUT 1-8	
Base Color Gamut	SMPTE ST 2084 EBU ITU-R BT.709 Adobe RGB DCI-P3 Native	When [LUT Type]  [Gamut LUT] Selects the color gamut used when creating the LUT.
Execute		Performs import.
LUT Name	You can specify the name of LUT within one-byte 24 characters including alphabetical characters, numbers, and symbols.	
LUT Type	User LUT Gamma LUT Gamut LUT	Select the LUT type.
Select LUT	User LUT 1-8 Gamma LUT 1-8 Gamut LUT 1-8	
Input Name		Input the LUT name.
LUT Delete	Deletes imported LUT.	
LUT Type	User LUT Gamma LUT Gamut LUT	Select the LUT type.
Select LUT	User LUT 1-8 Gamma LUT 1-8 Gamut LUT 1-8	
Delete		Deletes LUT.
YCbCr Color Matrix	Automatic ITU-R BT.709 ITU-R BT.2020	Sets the matrix conversion method for input signals in YCbCr format. [Automatic]: Matrix coefficient is set in conformance with the ITU-R BT.2020 standard when the [Picture Mode] or [Color Gamut] setting is [ITU-R BT.2020] and in conformance with the ITU-R BT.709 standard otherwise. [ITU-R BT.709]: Matrix coefficient is set in conformance with the ITU-R BT.709 standard. [ITU-R BT.2020]: Matrix coefficient is set in conformance with the ITU-R BT.2020 standard.

Sub Menu	Setting Options (Bold: factory default)	
2020 Constant Luminance	Constant Luminance Non-constant Luminance	When [Picture Mode]  [ITU-R BT.2020] Sets the color matrix conversion method. [Constant Luminance]: YUV signals are linearly converted and then converted into RGB signals. [Non-constant Luminance]: YUV signals are converted into RGB signals without changing gamma 0.45.
2020 Gamut Mapping	Gamut Mapping Clipping	When [Picture Mode] or [Color Gamut]  [ITU-R BT.2020] [Gamut Mapping]: Mapping is performed on colors outside the native color gamut by Canon's unique method. [Clipping]: Colors outside the native color gamut are clipped by a general method.
Hybrid Log-Gamma System	[Gamma]  When [Hybrid Log-Gamma Y] γ1.2 - 1000 cd/m² γ1.325 - 2000 cd/m ² γ1.45 - 4000 cd/m ² When [Hybrid Log-Gamma RGB] γ1.2 - 1000 cd/m² γ1.2 - 2000 cd/m ²	Sets the peak brightness. The maximum value for each setting becomes the upper limit value of [HDR Range].
HDR/SDR View ⁸	On, Off	In the [Multi View (Dual)] display, the HDR (High Dynamic Range) and SDR (Standard Dynamic Range) displays can be compared. [On]: The right screen is displayed at SDR luminance. [Off]: Does not compare the HDR and SDR display.
Calibration ⁹	When [Picture Mode]  [User 1] to [User 7] Executes calibration based on set target values. Can be run in the picture mode of the left screen in the [Multi View (Dual)] display.	
Luminance	48 to 300 (100) cd/m ²	Sets the target luminance.
Color Temperature	D93, D65 , D61, D60, D56, D50, DCI-P3 Custom (xy) • When Custom (xy) is selected x: 0.260 to 0.360 (0.313) y: 0.260 to 0.360 (0.329)	Sets the target color temperature. [D93], [D65], [D61], [D60], [D56], [D50], [DCI-P3]: Select from preset color temperatures. [Custom (xy)]: Adjusts CIE x and y. (Increments of 0.001)

Sub Menu	Setting Options (Bold: factory default)	
Color Gamut	SMPTE-C EBU ITU-R BT.709 ITU-R BT.2020 Adobe RGB DCI-P3	Sets the color gamut.
Gamma	2.2 , 2.35, 2.4, 2.6, ITU-R BT.1886	Sets the target gamma.
Start		Performs calibration.
Copy Picture Mode ¹⁰	When [Picture Mode] ► [User 1] to [User 7] Copy the Picture Mode settings.	
Picture Mode	SMPTE-C EBU ITU-R BT.709 ITU-R BT.2020 Adobe RGB DCI-P3 User 1 to User 7	Select the Picture Mode. [User 1] to [User 7]: Select from other than the currently set mode.
Execute		Performs copy.
Picture Mode Name		You can change the name of [User 1] to [User 7] within 16 characters including alphabetical characters, numbers, and symbols.
Anchor Adjustment	OK Cancel	Temporarily saves parameters for adjusting [Contrast], [Brightness], [Chroma], and [Sharpness] and recover the values (anchor point setting). [OK]: Performs anchor point setting. [Cancel]: Returns to the previous screen without setting anchor point.
Reset	OK Cancel	Return [Picture Mode] to factory default. Note that in [User 1] to [User 7] mode where you are performing calibration, the setting returns to the value after calibration instead of the factory default. When selected, the message [Reset Adjustment settings to defaults?] appears. [OK]: Performs reset. [Cancel]: Returns to the previous screen without resetting.

- ¹ In Multi View (Dual) display, it is not possible to set the function after selecting Picture Mode when the right screen is selected. The right screen's setting will be the same as set for the left screen.
- ² You cannot adjust when [User LUT] in [CDL/User LUT] is selected.
- ³
 - [Custom (xy)] and [Gain R/G/B] or [Bias R/G/B] cannot be selected at the same time.
 - When [Gain R/G/B] or [Bias R/G/B] value is adjusted, an asterisk [*] is displayed by color temperature preset mode.
 - The displayed color coordinates (x, y) are just a guide and not guaranteed absolute values.
- ⁴
 - For checking the video captured with Cinema EOS cameras, please refer to the "Parameter of Cinema EOS cameras and DP-V1710 (📖 71)".
 - Depending on the input image color range, this video display converts and shows them as follows. Data outside of the color range after conversion is also displayed at the optimum level. Data outside of the color gamut after conversion is also displayed at the optimum level.

Input video color gamut	Color gamut after conversion on the DP-V1710
ITU-R BT.2020	Native
Cinema Gamut to 709	ITU-R BT.709
Cinema Gamut to 2020	Native
Cinema Gamut to DCI	DCI-P3
DCI-P3+ to 709	ITU-R BT.709
DCI-P3+ to DCI	DCI-P3
DCI-P3 to 709	ITU-R BT.709
ITU-R BT.2020 to 709	ITU-R BT.709

- Setting is disabled when [User LUT] is set to [ARRI LUT 709] and is fixed to [ITU-R BT.709].
- Setting is disabled when [User LUT] is set to [ARRI LUT 2020] and is fixed to [ITU-R BT.2020].

- ⁵
- For checking the captured video with Cinema EOS cameras and ARRI cinema cameras, please refer to [Camera Link]  [Automatic Adjustment] (69).
 - The relationship between [Color Gamut] and [Gamma] that can be selected is shown below. When [Color Gamut] is changed, gamma is changed to the underlined value (default value) only when current gamma value is not selectable.

Picture Mode	Color Gamut	Selectable Gamma
SMPTE-C	Cannot be selected	Off, 1.0, <u>2.2</u> , 2.35, 2.4, 2.6, ITU-R BT.1886, Canon Log, Canon Log (HDR), SMPTE ST 2084, Gamma LUT 1 to Gamma LUT 8
EBU		Off, 1.0, 2.2, <u>2.35</u> , 2.4, 2.6, ITU-R BT.1886, Canon Log, Canon Log (HDR), SMPTE ST 2084, Gamma LUT 1 to Gamma LUT 8
ITU-R BT.709, ITU-R BT.2020		Off, 1.0, <u>2.2</u> , 2.35, 2.4, 2.6, ITU-R BT.1886, Canon Log, Canon Log (HDR), Canon Log 2, Canon Log 2 (HDR), Canon Log 3, Canon Log 3 (HDR), SMPTE ST 2084, Hybrid Log-Gamma Y, Hybrid Log-Gamma RGB, Gamma LUT 1 to Gamma LUT 8
Adobe RGB		Off, 1.0, <u>2.2</u> , 2.35, 2.4, 2.6, ITU-R BT.1886, Gamma LUT 1 to Gamma LUT 8
DCI-P3		Off, 1.0, 2.2, 2.35, 2.4, <u>2.6</u> , ITU-R BT.1886, Canon Log, Canon Log (HDR), Canon Log 2, Canon Log 2 (HDR), Canon Log 3, Canon Log 3 (HDR), SMPTE ST 2084, Gamma LUT 1 to Gamma LUT 8
Canon Log, User 1-7	SMPTE-C	Off, 1.0, <u>2.2</u> , 2.35, 2.4, 2.6, ITU-R BT.1886, Canon Log, Canon Log (HDR), SMPTE ST 2084, Gamma LUT 1 to Gamma LUT 8
	EBU	Off, 1.0, 2.2, <u>2.35</u> , 2.4, 2.6, ITU-R BT.1886, Canon Log, Canon Log (HDR), SMPTE ST 2084, Gamma LUT 1 to Gamma LUT 8
	ITU-R BT.709, ITU-R BT.2020	Off, 1.0, <u>2.2</u> , 2.35, 2.4, 2.6, ITU-R BT.1886, Canon Log, Canon Log (HDR), Canon Log 2, Canon Log 2 (HDR), Canon Log 3, Canon Log 3 (HDR), SMPTE ST 2084, Hybrid Log-Gamma Y, Hybrid Log-Gamma RGB, Gamma LUT 1 to Gamma LUT 8
	Adobe RGB	Off, 1.0, <u>2.2</u> , 2.35, 2.4, 2.6, ITU-R BT.1886, Gamma LUT 1 to Gamma LUT 8
	DCI-P3	Off, 1.0, 2.2, 2.35, 2.4, <u>2.6</u> , ITU-R BT.1886, Canon Log, Canon Log (HDR), Canon Log 2, Canon Log 2 (HDR), Canon Log 3, Canon Log 3 (HDR), SMPTE ST 2084, Gamma LUT 1 to Gamma LUT 8
	Native	Off, 1.0, <u>2.2</u> , 2.35, 2.4, 2.6, ITU-R BT.1886, SMPTE ST 2084, Gamma LUT 1 to Gamma LUT 8
	Cinema Gamut to 709, Cinema Gamut to DCI	<u>Canon Log</u> , Canon Log (HDR), Canon Log 2, Canon Log 2 (HDR), Canon Log 3, Canon Log 3 (HDR)
	Cinema Gamut to 2020	Canon Log, Canon Log (HDR), <u>Canon Log 2</u> , Canon Log 2 (HDR), Canon Log 3, Canon Log 3 (HDR)
	DCI-P3 to 709, ITU-R BT.2020 to 709	<u>Canon Log 2</u> , Canon Log 3
	DCI-P3+ to 709, DCI-P3+ to DCI	<u>Canon Log</u> , Canon Log (HDR)
Gamut LUT 1 to Gamut LUT 8	Off, 1.0, <u>2.2</u> , 2.35, 2.4, 2.6, ITU-R BT.1886, Gamma LUT 1 to Gamma LUT 8	

- ⁶ • Setting is disabled when [ACESproxy] is selected for [Picture Mode] or [ACESproxy] is selected for [Color Gamut].
- Operations when [Automatic] is selected are described below.
 - When HDMI is selected, [Full (0-255)] or [Limited 1 (16-235)] is set automatically depending on HDMI signal information.
 - When SDI is selected, the setting is configured according to the settings for [Picture Mode], [Color Gamut], and [Gamma].

	Setting Options	Color Range to be Set
Picture Mode	DCI-P3	Full (0-255)
Color Gamut	DCI-P3	
	Cinema Gamut to DCI DCI-P3+ to DCI	
Gamma	Canon Log (HDR) Canon Log 2 (HDR) Canon Log 3 (HDR) SMPTE ST 2084	Limited 2 (16-255)
	Canon Log Canon Log 2 Canon Log 3	
Other than the above		Limited 1 (16-235)

- ⁷ • When [User LUT] is selected, all [CDL] items, [Chroma], and [Blue Only] cannot be changed.
- [ARRI LUT 709] can be selected when [Picture Mode] is set to [ITU-R BT.709] or [User 1] to [User 7].
- [ARRI LUT 2020] can be selected when [Picture Mode] is set to [ITU-R BT.2020] or [User 1] to [User 7].
- ⁸ • Cannot be set when [Picture Mode] is selected in the right screen.
- When the [Contrast] setting for the left screen is specified as [1000] or less, the luminance of the left and right screens is the same.
- ⁹ • Calibration cannot be executed when using DC power.
- When [Luminance] is set to high brightness, it may be calibrated beyond the brightness adjustment range and set lower than the target value, depending on the [Color Temperature] setting. In that case, set the [Luminance] again.
- Cannot be run in [Picture Mode] of the right screen in the [Multi View (Dual)] display.
- ¹⁰ In [Picture Mode] other than [User 1] to [User 7], the results of calibration performed at the factory are copied.

■ Details of the factory default settings for each [Picture Mode]

Item		SMPTE-C	EBU	ITU-R BT. 709	ITU-R BT.2020	Adobe RGB
Contrast		1000	1000	1000	1000	1000
Brightness		0	0	0	0	0
Chroma		1000	1000	1000	1000	1000
Sharpness		0	0	0	0	0
Local Dimming		Low	Low	Low	Low	Low
Color Temperature	Preset	D65	D65	D65	D65	D65
	x	0.313	0.313	0.313	0.313	0.313
	y	0.329	0.329	0.329	0.329	0.329
	Gain R/G/B	1023	1023	1023	1023	1023
	Bias R/G/B	0	0	0	0	0
Gamma		2.2	2.35	2.2	2.2	2.2
Color Gamut		SMPTE-C	EBU	ITU-R BT.709	ITU-R BT.2020	Adobe RGB
Color Range		Automatic	Automatic	Automatic	Automatic	Automatic
Input Transform		-	-	-	-	-
Output Transform		-	-	-	-	-
Output Transform Surround		-	-	-	-	-
CDL Preset		CDL 1	CDL 2	CDL 3	CDL 4	CDL 5
User LUT		User LUT 1	User LUT 1	User LUT 1	User LUT 1	User LUT 1
YCbCr Color Matrix		Automatic	Automatic	Automatic	Automatic	Automatic
2020 Constant Luminance		Non-constant Luminance	Non-constant Luminance	Non-constant Luminance	Non-constant Luminance	Non-constant Luminance
2020 Gamut Mapping		Gamut Mapping	Gamut Mapping	Gamut Mapping	Gamut Mapping	Gamut Mapping
Hybrid Log-Gamma System		$\gamma_{1.2}$ - 1000 cd/m ²	$\gamma_{1.2}$ - 1000 cd/m ²	$\gamma_{1.2}$ - 1000 cd/m ²	$\gamma_{1.2}$ - 1000 cd/m ²	$\gamma_{1.2}$ - 1000 cd/m ²
HDR/SDR View		Off	Off	Off	Off	Off

Item		DCI-P3	User 1 to User 7	Canon Log	ACESproxy
Contrast		480	1000	1000	480
Brightness		0	0	0	0
Chroma		1000	1000	1000	1000
Sharpness		0	0	0	0
Local Dimming		Low	Low	Low	Low
Color Temperature	Preset	DCI-P3	D65	D65	D60
	x	0.314	0.313	0.313	0.322
	y	0.351	0.329	0.329	0.338
	Gain R/G/B	1023	1023	1023	1023
	Bias R/G/B	0	0	0	0
Gamma		2.6	2.2	Canon Log	–
Color Gamut		DCI-P3	ITU-R BT.709	ITU-R BT.709	ACESproxy
Color Range		Automatic	Automatic	Automatic	Automatic
Input Transform		–	–	Automatic	Automatic
Output Transform		–	–	DCI-P3	DCI-P3
Output Transform Surround		–	–	Dark Surround	Dark Surround
CDL Preset		CDL 6	CDL 7-13	CDL 14	CDL 15
User LUT		User LUT 1	User LUT 1	User LUT 1	User LUT 1
YCbCr Color Matrix		Automatic	Automatic	Automatic	Automatic
2020 Constant Luminance		Non-constant Luminance	Non-constant Luminance	Non-constant Luminance	Non-constant Luminance
2020 Gamut Mapping		Gamut Mapping	Gamut Mapping	Gamut Mapping	Gamut Mapping
Hybrid Log-Gamma System		γ 1.2 - 1000 cd/m ²	γ 1.2 - 1000 cd/m ²	γ 1.2 - 1000 cd/m ²	γ 1.2 - 1000 cd/m ²
HDR/SDR View		Off	Off	Off	Off

Channel Settings

This menu is used for input related settings. Select the [Select Channel] and choose a channel number from CH1 to CH20. Finally define the parameter of each of the [Channel Settings].

❖ "Supported Signal Format" (📖 82)

Sub Menu	Setting Options	
Select Channel ¹	CH1 to CH20	Display the channel number. In addition, you can assign each content of [Channel Settings] to each channel (📖 34).
Input Configuration	6G/3G/HD-SDI 3G-SDI RAW HDMI — (Not set)	Select the input. Factory default depend on the channel (📖 34).
Select Input Signal ²	Automatic Quad Input Dual Input A,B Dual Input C,D Single Input A Single Input B Single Input C Single Input D	Sets the signal display method (📖 20). [Automatic]: The display method is automatically determined to match the input signal. [Quad Input]: Four input signals (Input A to Input D terminals) are displayed. [Dual Input A,B]: Two input signals (Input A terminal and Input B terminal) are displayed. [Dual Input C,D]: Two input signals (Input C terminal and Input D terminal) are displayed. [Single Input A], [Single Input B], [Single Input C], [Single Input D]: One input signal (any of Input A to Input D) is displayed.

Sub Menu	Setting Options	
Image Division	<p>Sets the display method when using either [Quad Input] or [Dual Input]. Two division methods "Square Division" and "2 Sample Interleave" are supported for 4K video signals.</p> <p>When [Input Configuration] ► [6G/3G/HD-SDI], and [Select Input Signal] ► [Quad Input]</p> <p>Automatic Square Division 2 Sample Interleave Multi View (Quad)</p> <p>When [Input Configuration] ► [6G/3G/HD-SDI], and [Select Input Signal] ► [Dual Input A,B] or [Dual Input C,D]</p> <p>Automatic Square Division 2 Sample Interleave Dual Link 3G-SDI Multi View (Dual)</p>	<p>[Automatic]: Automatically determined based on payload and displayed. [Square Division]: Displays a signal transmitted over four inputs as a single image. [2 Sample Interleave]: Displays a signal transmitted divided into a 2K/HD signal as a single image. [Multi View (Quad)]: Each of the images from the four inputs (each input up to a 1920x1080 signal) are shown in four screens.</p> <p>[Automatic]: Automatically determined based on payload and displayed. [Square Division]: Displays a signal transmitted over four inputs as a single image. [2 Sample Interleave]: Displays a signal transmitted divided into a 2K/HD signal as a single image. [Dual Link 3G-SDI]: Displays a Dual Link 3G-SDI signal as a single image. [Multi View (Dual)]: Each of the images (Inputs A/B or Inputs C/D) from the two inputs (each input up to a 1920x1080 signal) are shown in two screens.</p> <div data-bbox="719 1050 1394 1216" style="text-align: center;"> <p>The diagram illustrates the 'Square Division' setting. On the left, four separate rectangular images are arranged in a 2x2 grid, each showing a different portion of a building. An arrow points to the right, where a single, larger square image is shown, which is a composite of the four individual images, demonstrating how they are combined into a single frame.</p> </div> <p>Select Input Signal: Quad Input, Image Division: Square Division</p>
Format ³	<p>SDI Signal Automatic 4:2:2 YCbCr 10-bit 4:2:2 YCbCr 12-bit 4:4:4 YCbCr 10-bit 4:4:4 YCbCr 12-bit 4:4:4 RGB 10-bit 4:4:4 RGB 12-bit 4:4:4 XYZ 10-bit 4:4:4 XYZ 12-bit</p> <p>HDMI Signal Automatic 4:4:4 XYZ 12/10-bit</p>	<p>Sets the color format and gradation.</p> <p>[Automatic]: Sets automatically to match the input signal.</p>
Internal Sync	<p>On, Off</p>	<p>When [Image Division] ► [Square Division]</p> <p>Sets whether to synchronize four inputs.</p> <p>[On]: Force synchronization. [Off]: Do not force synchronization.</p>

Sub Menu	Setting Options	
Channel Name		Sets the name of the selected channel. You can input up to 16 alphanumeric characters.
Picture Mode		Sets the [Picture Mode].
Picture Mode R		Sets the [Picture Mode] for the right screen in the [Multi View (Dual)] display.
Audio Input ⁴	[Select Input Signal] ▶ When [Automatic] or [Quad Input] Input A, Input B, Input C, Input D When [Dual Input A,B] Input A, Input B When [Dual Input C,D] Input C, Input D	Sets the audio terminal.
Marker/TC/WFM/VEC Input ⁵	[Select Input Signal] ▶ When [Automatic] or [Quad Input] Input A, Input B, Input C, Input D When [Dual Input A,B] Input A, Input B When [Dual Input C,D] Input C, Input D	In the [Multi View (Quad)] or [Multi View (Dual)] display, sets the target terminal so that various markers (except Grid Marker), Time Code, Wave Form Monitor, Vector Scope and Camera Information are displayed. (Camera Information is available in the [Multi View (Quad)] display only)
Picture Function Target	Left and Right Left Right	In the [Multi View (Dual)] display, sets the screen for enabling image quality setting functions in the function settings. Function Settings where displays change due to this function: [Peaking], [False Color], [Various Function (Monochrome, Blue Only, Red Off, Green Off, Blue Off)] [Left and Right]: Entire screen [Left]: Left screen only [Right]: Right screen only
Separator	On, Off	In the [Multi View (Quad)] or [Multi View (Dual)] display, displays the border lines of the screen.

¹ It may take 10 seconds when switching channels.

² Settings that can be set differ according to the input signal.

- HDMI: This is fixed to [Automatic].

³ • HD-SDI signal is [4:2:2 YCbCr 10-bit] regardless of the setting.

• For [3G-SDI RAW], the setting is fixed to [Automatic].

• If [Automatic] is selected, they are rendered in a Payload that is selected in the order A → B → C → D.

• To use 4:4:4 XYZ 10-bit for SDI signals, select [4:4:4 XYZ 10-bit]. Then, signals will be processed as signals where XYZ data is included in RGB data output in 4:4:4 RGB 10-bit format.

⁴ When [Single] is selected, this is fixed to input signal terminal.

⁵ This setting becomes invalid except for the [Multi View (Quad)] or [Multi View (Dual)] display.

Display Settings

This menu is used to configure the display method.

56

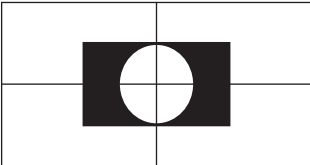
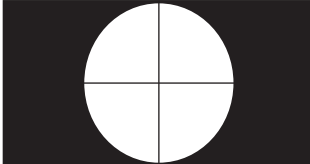
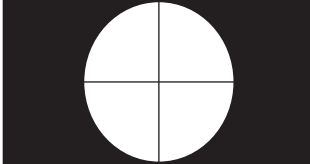
Sub Menu	Setting Options (Bold: factory default)	
Screen Scaling ¹	Native Input Resolution 200% Automatic	<p>Defines how the video is scaled and displayed on the screen.</p> <p>[Native Input Resolution]: Displays the input signal without scaling.</p>  <p>1920x1080 (original)</p> <p>[200%]: Doubles the vertical and horizontal dimensions.</p>  <p>1920x1080→3840x2160</p> <p>[Automatic]: Enlarges to full screen.</p>  <p>1920x1080→3840x2160</p>

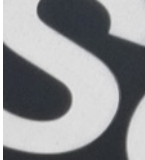
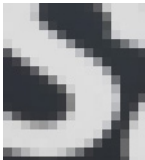
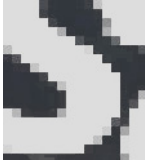
Sub Menu	Setting Options (Bold: factory default)	
Scaling Method	Shape Trace Bicubic Nearest Neighbor	<p>Sets the interpolation method when [Screen Scaling] is set to [200%] or [Automatic].</p> <p>[Shape Trace]: Canon original processing that produces smooth slopes with reduced jagged lines.</p>  <p>[Bicubic]: General interpolation process that uses neighboring pixel information to create interpolated pixels.</p>  <p>[Nearest Neighbor]: Process that uses nearest neighbor pixel information to create (copy) new pixels. This is useful as it enlarges the original pixels, thus making any jagged lines visible.</p> 
Zoom ²	Enlarges part of the video image. The zoom function can be used when the resolution is [4096x2160], [3840x2160], [2048x1080] or [1920x1080].	
Zoom Preset	Zoom 1 Zoom 2 Zoom 3 Off	Sets the zoom display method. There are three presets.
Magnification	x2 x4 x8	Sets the display scale of zoom.
Position		The zoom adjustment screen is displayed. Use the jog dial to adjust the display position.
Frame Hold ³	On, Off	Pauses the video.
I/PsF	Automatic Interlace PsF	<p>Defines how the interlace signal or PsF signal is displayed.</p> <p>[Automatic]: Automatically determined based on payload and displayed. If there is no payload, the signal is displayed as an interlace signal.</p> <p>[Interlace]: Displayed as an interlace signal.</p> <p>[PsF]: Displayed as a PsF signal.</p>

Sub Menu	Setting Options (Bold: factory default)	
Psf	Progressive Interlace	<p>Defines how the PsF signal is displayed.</p> <p>[Progressive]: Interpolates giving preference to image quality by detecting paired fields.</p> <p>[Interlace]: Interpolates using two adjacent fields giving priority to speed.</p>
I/P Conversion	Image Priority Speed Priority	<p>Sets the interlaced signal I/P conversion method.</p> <p>[Image Priority]: This mode gives priority to image quality. Processing time will be longer than [Speed Priority].</p> <p>[Speed Priority]: This mode gives priority to speed.</p>
Film Cadence ⁴	2-2 2-3 2-3-3-2 Off	<p>Sets the film cadence mode.</p> <p>[2-2]: Displays progressive image after conversion for 2-2 pulldown processed interlaced signal input.</p> <p>[2-3]: Displays progressive image after conversion for 2-3 pulldown processed interlaced signal input.</p> <p>[2-3-3-2]: Displays progressive image after conversion for 2-3-3-2 pulldown processed interlaced signal input.</p> <p>[Off]: Does not perform film cadence mode progressive conversion.</p>

¹ In the following cases, the maximum magnification is 200% even if [Automatic] is selected.

- When [Peaking] or [False Color] is [On]
- When [Multi View (Dual)] is selected

² • The zoom function cannot be used in the following cases:

- During execution of [Playback File] under [Screen Capture]
- During display of the test pattern
- When [Multi View (Quad)] or [Multi View (Dual)] is selected
- While the zoom function is in use, the following are not displayed:
Various markers, Wave Form Monitor, Vector Scope
- When zoom settings are changed, [Frame Hold] turns [Off].
- When the resolution is [1920x1080], the display position cannot be changed even if [Magnification] is set to [x2].

³ Setting is disabled when [Peaking] or [False Color] is set to [On].

⁴ • This can be set only when [I/P Conversion] is set to [Image Priority].

- Cannot be set in the [Multi View (Quad)] or [Multi View (Dual)] display. The setting is fixed to [Off].





Audio Settings





This menu is used to set audio output from the headphone terminal.





Sub Menu	Setting Options (Bold: factory default)	
SDI Group	CH1-CH8 CH9-CH16	Switches the audio group to be input during SDI audio input.
CH L (SDI)	[SDI Group] ► When [CH1-CH8] CH1 to CH8 (CH1) When [CH9-CH16] CH9 to CH16 (CH9)	Sets the audio to be output from the two channels (L/R) of the headphone respectively. The options differ according to the [SDI Group] setting.
CH R (SDI)	[SDI Group] ► When [CH1-CH8] CH1 to CH8 (CH2) When [CH9-CH16] CH9 to CH16 (CH10)	
CH L (HDMI)	CH1 to CH8 (CH1)	Sets the audio to be output from the two channels (L/R) of the headphone respectively.
CH R (HDMI)	CH1 to CH8 (CH1)	
Volume	0 to 100 (30)	Sets the volume. (Increments of 1)
Audio Switch	L R L R MIX (L+R)	Sets the stereo output.

Marker Settings

This menu is used to configure various markers.

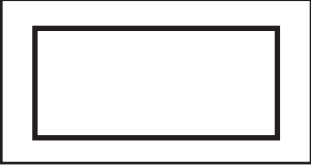
Sub Menu	Setting Options (Bold: factory default)	
Marker Preset	Marker 1 to 5 Off	Customizes markers which are assigned to markers 1 to 5.
Aspect Marker ¹	<p>[Aspect Marker] displays a range in accordance with the specified aspect ratio.</p> 	
Enable	On, Off	Switches the aspect marker On, Off.
Mask	Black Half Off	<p>Switches the mask color. Mask is the blanking area outside the range of the marker.</p> <p>[Black]:</p>  <p>[Half] (50% gray):</p>  <p>[Off]: Turns mask off.</p>
Aspect Ratio	<p>16:9, 15:9, 14:9, 13:9, 4:3, 2.39:1, 2.35:1, 1.896:1, 1.85:1, 1.66:1, Variable</p> <ul style="list-style-type: none"> When Variable is selected 1.00:1 to 3.00:1 (1.78:1) 	<p>Sets the aspect ratio of the aspect marker.</p> <p>The aspect ratio can be entered as a numeric value when you select [Variable] (0.01:1 increments). The grayed out slider becomes active and can be used to set the aspect ratio.</p>
Line	On , Off	When [Mask]  [Black] or [Half] Switches lines on mask On, Off.
Line Width	Thick Normal Thin	Sets the thickness of the aspect marker line.

Sub Menu	Setting Options (Bold: factory default)	
Line Color	White , Red, Green, Blue, Yellow, Cyan, Magenta	Sets the color of the aspect marker line.
Line Brightness	High Low	Sets the brightness of the aspect marker line.
H Position	-65 to 65 (0)	Changes horizontal position without changing the aspect.
V Position	-35 to 35 (0)	Changes vertical position without changing the aspect.
Safety Zone Marker 1, 2 ¹	<p>There are two types of [Safety Zone Marker]: 1 and 2, which share the same settings. A safety zone marker is used to set the safe zone of the image (actual displayed area) to check the image.</p> 	
Enable	On, Off	Switches the safety zone marker On, Off.
Aspect Ratio ²	16:9 , 15:9, 14:9, 13:9, 4:3, 2.39:1, 2.35:1, 1.896:1, 1.85:1, 1.66:1, Variable <ul style="list-style-type: none"> When Variable is selected 1.00:1 to 3.00:1 (1.78:1) 	<p>Sets the aspect ratio of the safety zone marker.</p> <p>[Variable]: The aspect ratio can be entered as a numeric value (0.01:1 increments). The grayed out slider becomes active and can be used to set the aspect ratio.</p>
Area Size	80% , 88%, 90%, 93%, Variable (%), Variable (dot)	<p>Sets the safety zone marker area size.</p> <p>[Variable (%)] : The grayed out [Rate (%)] becomes active. [Variable (dot)] : The grayed out [Width (dot)] and [Height (dot)] become active.</p>
Rate (%)	50 to 100 (80)	<p>When [Area Size]  [Variable (%)]</p> <p>Move the slider to set the displayed marker area size without changing the aspect ratio in 1 % increments.</p>
Width (dot)	360 to 3840 (3072)	<p>When [Area Size]  [Variable (dot)]</p> <p>Move the slider to set the area width in 2 dot increment.</p>
Height (dot)	240 to 2160 (1728)	<p>When [Area Size]  [Variable (dot)]</p> <p>Move the slider to set the area height in 2 dot increment.</p>

Sub Menu	Setting Options (Bold: factory default)	
Shape	Box Bracket Enclosure	Sets the area shape of the safety zone marker. [Box]:  [Bracket]:  [Enclosure]: 
Line Width	Thick Normal Thin	Sets the width of the safety zone marker line.
Line Color	White , Red, Green, Blue, Yellow, Cyan, Magenta	Sets the color of the safety zone marker line.
Line Brightness	High Low	Sets the brightness of the safety zone marker line.
H Position	-65 to 65 (0)	Adjusts the marker horizontal position with the set aspect and size.
V Position	-35 to 35 (0)	Adjusts the marker vertical position with the set aspect and size.
Area Marker ¹	[Area Marker] is used to check a specific area using a rectangular box. 	
Enable	On, Off	Switches the area marker On, Off.
H Position	0 to 3830 (240)	Sets the start position (x-coordinate) to draw the rectangle. (in increments of 2)
V Position	0 to 2150 (120)	Sets the start position (y-coordinate) to draw the rectangle. (in increments of 2)
Width (dot)	10 to 3840 (240)	Sets the width of the rectangle. (in increments of 2)

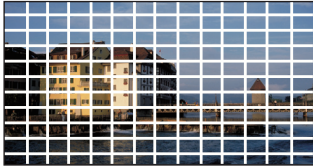
Sub Menu	Setting Options (Bold: factory default)	
Height (dot)	10 to 2160 (120)	Sets the height of the rectangle. (in increments of 2)
Mask	Black Half Off	Switches the mask color (in the marker).
Line	On , Off	When [Mask] ► [Black] or [Half] Turns On/Off the outlines of the rectangular box.
Line Width	Thick Normal Thin	Sets the width of the area marker line.
Line Color	White , Red, Green, Blue, Yellow, Cyan, Magenta	Sets the color of the area marker line.
Line Brightness	High Low	Sets the brightness of the area marker line.
Center Marker ³	[Center Marker] shows the center of the image. 	
Enable	On, Off	Switches the center marker On, Off.
Size	Large Small	Sets the size of the center marker.
Line Width	Thick Normal Thin	Sets the width of the center marker line.
Line Color	White , Red, Green, Blue, Yellow, Cyan, Magenta	Sets the color of the center marker line.
Line Brightness	High Low	Sets the brightness of the center marker line.
Grid Marker ³	[Grid Marker] is marker used to check the horizontal and vertical position. 	
Enable	On, Off	Switches the grid marker On, Off.
Distance	160 dots 240 dots 320 dots	Sets the horizontal and vertical line distance.

Sub Menu	Setting Options (Bold: factory default)	
Line Width	Thick Normal Thin	Sets the width of the grid marker line.
Line Color	White , Red, Green, Blue, Yellow, Cyan, Magenta	Sets the color of the grid marker line.
Line Brightness	High Low	Sets the brightness of the grid marker line.

¹ The marker is not displayed in the following cases:

- When there is no signal, unsupported signal, or a channel with [Input Configuration] not set is selected
- When an enlarged image is displayed
- During the execution of [Playback File] under [Screen Capture]
- When a [Test Pattern] is displayed















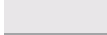









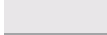





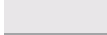

² When [Area Size] is set to [Variable (dot)], you cannot select [Aspect Ratio].

³ The marker is not displayed in the following cases:

- When an enlarged image is displayed

Function Settings





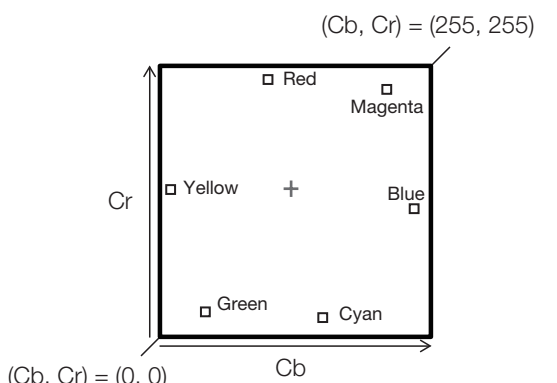

This menu is used to set functions to link with Cinema EOS cameras and video assistance functions.

Sub Menu	Setting Options (Bold: factory default)																																		
Peaking ¹	Customizes peakings which are assigned to Peaking 1 or Peaking 2. The outline is displayed in a color, used to check the focus.																																		
Enable	Peaking 1 Peaking 2 Off	Switches the peaking display mode and also sets peaking to Off. Configures detailed settings for [Peaking 1] or [Peaking 2].																																	
Monochrome	On , Off	Displays video in monochrome.																																	
Frequency	When [Enable] ▶ [Peaking 1] Low Middle High When [Enable] ▶ [Peaking 2] Low Middle High	Sets the central frequency of contour enhancement signals.																																	
Range	-3 ~ +3 (0)	Sets the width of the range to be colored.																																	
Color	White, Red , Green, Blue, Yellow, Cyan, Magenta	Sets the color to be used.																																	
False Color ²	On , Off	<p>When set to [On], different colors are displayed according to video's brightness level so that you can check the exposure condition easily. Below are details of the chart. Numbers indicate the level of Y-signals.</p> <table border="0"> <tr> <td>941 ~ 1023</td> <td></td> <td>Red</td> </tr> <tr> <td>877 ~ 940</td> <td></td> <td>Orange</td> </tr> <tr> <td>813 ~ 876</td> <td></td> <td>Light orange</td> </tr> <tr> <td>749 ~ 812</td> <td></td> <td>Yellow</td> </tr> <tr> <td>584 ~ 748</td> <td></td> <td>Light gray</td> </tr> <tr> <td>420 ~ 583</td> <td></td> <td>Medium gray</td> </tr> <tr> <td>256 ~ 419</td> <td></td> <td>Dark gray</td> </tr> <tr> <td>192 ~ 255</td> <td></td> <td>Blue</td> </tr> <tr> <td>128 ~ 191</td> <td></td> <td>Blue purple</td> </tr> <tr> <td>64 ~ 127</td> <td></td> <td>Light purple</td> </tr> <tr> <td>0 ~ 63</td> <td></td> <td>Purple</td> </tr> </table>	941 ~ 1023		Red	877 ~ 940		Orange	813 ~ 876		Light orange	749 ~ 812		Yellow	584 ~ 748		Light gray	420 ~ 583		Medium gray	256 ~ 419		Dark gray	192 ~ 255		Blue	128 ~ 191		Blue purple	64 ~ 127		Light purple	0 ~ 63		Purple
941 ~ 1023		Red																																	
877 ~ 940		Orange																																	
813 ~ 876		Light orange																																	
749 ~ 812		Yellow																																	
584 ~ 748		Light gray																																	
420 ~ 583		Medium gray																																	
256 ~ 419		Dark gray																																	
192 ~ 255		Blue																																	
128 ~ 191		Blue purple																																	
64 ~ 127		Light purple																																	
0 ~ 63		Purple																																	
Time Code ³	Display the time code superimposed on the signal.																																		
																																			
Enable	On , Off	Switches the time code display On, Off.																																	
Type ⁴	VITC LTC	Selects the type.																																	

Sub Menu	Setting Options (Bold: factory default)	
Size	Large Small	Selects the size.
Position ⁵	Top Left Top Right Bottom Left Bottom Right	Selects the display position.
Wave Form Monitor ⁶	<p>Configures various settings for the wave form monitor. On the wave form monitor, the horizontal axis shows the horizontal resolution of the video and the vertical line shows the signal level.</p> <div style="text-align: center;"> </div>	
Enable	On, Off	Switches the wave form monitor On, Off.
Select Signal	Y , Cb, Cr, R, G, B	Sets the waveform to be displayed.
Display Type	All Line	Sets the display type. [Line]: The data for one line is displayed.
Select Line	<ul style="list-style-type: none"> When Line is selected 1 to 2160	Selects the line to be displayed when [Line] is selected.
Position ⁵	Bottom Left Bottom Right	Selects the display position.
Scale	Automatic IRE Canon Log Canon Log 2 Canon Log 3 SMPTE ST 2084	Sets the scale of the wave form monitor. [Automatic]: Sets in accordance with the gamma settings.
Guide	1 to 255	A guide is displayed at the specified position. [Guide] is not displayed when [255] is selected.
Standard Level High	190 to 255	Sets the standard display level (high). [Standard Level High] is not displayed when [255] is selected.
Standard Level Low	0 to 64	Sets the standard display level (low). [Standard Level Low] is not displayed when [0] is selected.
Color	Sets the signals to be displayed and the color of signals exceeding the standard level.	
Y	White	[Y], [Cb], [Cr], [R], [G], [B]: Selects the color of the selected signal. Default value of each signal is shown below. Y (White), Cb (White), Cr (White), R (Red), G (Green), B (Blue) [Standard Level High], [Standard Level Low]: Selects the color of the signal of the selected standard level. Default value of each standard level is shown below. Standard Level High (Magenta), Standard Level Low (Cyan)
Cb	Red	
Cr	Green	
R	Blue	
G	Yellow	
B	Cyan	
Standard Level High	Magenta	
Standard Level Low		

Sub Menu	Setting Options (Bold: factory default)	
Vector Scope ⁶	Configures various settings for the vector scope. Vector scope displays the intensity of color signals and hue with the horizontal axis showing the color difference signal Cb and the vertical line showing Cr. <div style="text-align: center; margin-top: 20px;">  </div>	
Enable	On, Off	Switches the vector scope On, Off.
Target	75% 100%	Sets the target.
Position ⁵	Bottom Left Bottom Right	Selects the display position.
Audio Level Meter ⁷	Configures various settings for the audio level meter. Displays the audio level of the selected channel number.	
Enable	On, Off	Switches the audio level meter On, Off.
Channel Number (SDI)	2CH 4CH 6CH 8CH	Sets the number of channels displayed when SDI signal is input. Options change according to the setting for [SDI Group] under [Audio Settings]. When [SDI Group] ▶ [CH1-CH8] [2CH]: CH1 to CH2 [4CH]: CH1 to CH4 [6CH]: CH1 to CH6 [8CH]: CH1 to CH8 When [SDI Group] ▶ [CH9-CH16] [2CH]: CH9 to CH10 [4CH]: CH9 to CH12 [6CH]: CH9 to CH14 [8CH]: CH9 to CH16
Channel Number (HDMI)	2CH 4CH 6CH 8CH	Sets the number of channels displayed when HDMI signal is input. [2CH]: CH1 to CH2 [4CH]: CH1 to CH4 [6CH]: CH1 to CH6 [8CH]: CH1 to CH8
Peak Hold	On , Off	One second of audio signal at the peak is kept.
Standard Level	-40 to 0 (-20)	Sets the standard level.

Sub Menu	Setting Options (Bold: factory default)	
Test Pattern ⁸	White, Gray (20%), Black, Red, Green, Blue, Ramp, 5 Step, Color Bars, PLUGE, Off	Sets the test pattern built into the main unit.
Screen Capture ⁹	Captures the screen.	
Capture		Captures the screen. The data is saved under the name "YYYYMMDD_hhmmss.bmp" in the root folder of the USB memory.
Frame Hold	On, Off	Pauses the video.
Capture Source	All Video	Selects the sources to capture. [All]: Everything is captured including video assistance functions such as markers and wave form monitor as well as OSD menu. [Video]: Only video signals are captured.
Playback File ¹⁰	Select File Execute	Plays back captured images. [Select File]: Selects a file. [Execute]: Plays back the image.
Finish Playback File		Finishes playback.
Various Function	Displays the function list to execute functions.	
Monochrome	On, Off	
Blue Only ¹¹	On, Off	
Red Off	On, Off	
Green Off	On, Off	
Blue Off	On, Off	
Banner	On , Off	[Off]: The banner is displayed only when you press the jog dial while OSD is closed.
Function Guide	On , Off	[On]: You can display the list of functions assigned to an F button on the video display by pressing the jog dial while OSD is closed. [Off]: Function guide is not displayed.

Sub Menu	Setting Options (Bold: factory default)	
Camera Link 	Sets the functions to link with Cinema EOS cameras and ARRI cinema cameras.	
Automatic Adjustment (CINEMA EOS)	When [Picture Mode]  [Canon Log] Sets whether or not to link to the camera's image quality setting (when [SG-SDI RAW] is selected for [Input Configuration] only).	
	On, Off	Refer to the Setting Values Correspondence Table when [Color Gamut/Gamma], [Color Temperature], and [Color Range] are all set to [On]. ( 71)
	Color Gamut/Gamma	The image quality of the display corresponds to the gamma and color gamut of the camera.
	Color Temperature	The image quality of the display corresponds to the color temperature of the camera.
	Color Range	The image quality of the display corresponds to the range of the camera.
Display Color Gamut	ITU-R BT.709 ITU-R BT.2020 DCI-P3	Sets the color gamut shown on the display when the camera's [Color Space] is set to [Cinema Gamut] or [DCI-P3+].
Automatic Adjustment (ARRI)	When [Picture Mode]  [User 1] to [User 7] Sets whether or not to link to the camera's image quality setting.	
	On, Off	When [CDL/User LUT]  [User LUT] Refer to the Setting Values Correspondence Table when [ARRI LUT 709] or [ARRI LUT 2020] are selected. ( 71)
	User LUT/Color Gamut	The image quality of the display corresponds to the settings of [User LUT] and color gamut of the camera.
Color Range	On , Off	The image quality of the display corresponds to the range of the camera.
Area Marker ¹²	ARRI Frame line 1A ARRI Frame line 1B Off	When an ARRI cinema camera is connected to this device, the [H Position], [V Position], [Width], and [Height] for the [Area Marker] change depending on the meta information.
Fan ¹³	On , Off	Sets whether or not to stop the fan by linking with the camera's REC signal. When [Fan Control] under [System Settings] is set to [On], the mode changes so that the fan can be stopped, and when [Fan] is set to [On], the fan can be stopped by linking with the camera's REC signal. At room temperature (25 °C), the fan remains off for approximately one minute (about 10 minutes when using DC power). The fan operates at a faster speed than usual before and after the fan is stopped to lower the internal temperature.
Camera Information	Automatic On Off	Sets conditions to display camera information. [Automatic]: Camera information is displayed for 4 seconds when the information has changed. [On]: Camera information is always displayed. [Off]: Camera information is not displayed.

¹ [Peaking] cannot be displayed during the execution of [Playback File] under [Screen Capture].

² [False Color] cannot be displayed during the execution of [Playback File] under [Screen Capture].

³ [Time Code] cannot be displayed in the following cases:

- When [Frame Hold] is [On]
- During the execution of [Playback File] under [Screen Capture]
- When the location selected for [Time Code] and [Audio Level Meter] to be displayed is the same
- When [Test Pattern] is displayed

⁴ This setting becomes invalid when HDMI signal is input and is fixed to [VITC].

⁵ This setting becomes invalid in the [Multi View (Dual)] display.

- ⁶ • [Wave Form Monitor] or [Vector Scope] cannot be displayed in the following cases:
 - When an enlarged image is displayed
 - When [Frame Hold] (during interlace signal or PsF signal) or [False Color] is [On]
 - When [Peaking 1] or [Peaking 2] is selected
 - During execution of [Playback File] under [Screen Capture]
 - While [Test Pattern] is displayed
- Only the signal set by [Marker/TC/WFM/VEC Input] is displayed in the [Multi View (Quad)] or [Multi View (Dual)] display.
- When [Wave Form Monitor] is set to [On], [Vector Scope] turns [Off]. When [Vector Scope] is set to [On], [Wave Form Monitor] turns [Off].
- ⁷ [Audio Level Meter] cannot be displayed when [Frame Hold] is [On], during the execution of [Playback File] under [Screen Capture], or when [Test Pattern] is displayed.
- ⁸ • If the power is turned off once and then back on, the test pattern will not be displayed.
- The test pattern will be erased in the following cases:
 - When calibration has been started
 - When the channel is changed using the CH button, F button assigned for Channel UP/Channel DOWN, or [Select Channel] under [Channel Settings]
 - When changing [Input Configuration] or [Select Input Signal] under [Channel Settings]
 - When [Reset All Settings] is executed
- ⁹ Setting is disabled when [Multi View (Quad)] or [Multi View (Dual)] is selected.
- ¹⁰ When playing back captured images on other DP-V1710 or PC, color may not be played back precisely.
- ¹¹ When [CDL/User LUT] is set to [User LUT], [Blue Only] cannot be selected.
- ¹² This cannot be displayed when [Marker Preset] is [Off].
- ¹³ • This can be operated in [On] with REC signals supported by this function (Cinema EOS cameras, Canon professional-use video cameras, ARRI cinema cameras).
 - If the temperature inside the main unit increases while the fan is off, the message [Fan will be rotated as the temperature is high.] is displayed and the fan starts rotating approximately ten seconds later. Since the temperature of the main unit has increased, the fan rotates faster than usual.
 - The video display's fan may start rotating earlier than the camera because the temperature inside the main unit has increased.
 - The fan may not stop in some conditions, for example when used at a high temperature.

■ Parameter of Cinema EOS cameras and DP-V1710

Cinema EOS cameras		DP-V1710			
Color Space	Gamma	Color Gamut	Gamma	Color Temperature	Color Range
BT.709	Canon Log	ITU-R BT.709	Canon Log	D65	Automatic
BT.2020		ITU-R BT.2020		D65	
Cinema Gamut		Cinema Gamut to 709		D65	
		Cinema Gamut to 2020		D65	
		Cinema Gamut to DCI-P3		DCI-P3	
DCI-P3+		DCI-P3+ to 709		D65	
		DCI-P3+ to DCI-P3		DCI-P3	
BT.2020	Canon Log 2	ITU-R BT.2020	Canon Log 2	D65	
Cinema Gamut		Cinema Gamut to 709		D65	
		Cinema Gamut to 2020		D65	
		Cinema Gamut to DCI-P3		DCI-P3	

■ Parameter of ARRI Cinema camera and DP-V1710

ARRI Cinema camera		DP-V1710		
Color Space	User LUT	Color Gamut	Color Range	
REC 709	ARRI LUT 709	ITU-R BT.709	Automatic (Limited 1)	
REC 2020	ARRI LUT 2020	ITU-R BT.2020		

System Settings

This menu is used to configure settings related the system of the video display.

Sub Menu	Setting Options (Bold: factory default)	
Function/Channel Button	Sets the function or channel to assign to the F buttons or CH button.	
Display Function/ Display Function (CDL)	Sets the function to assign to the F buttons of the main unit (📖33). Select an F button and assign a function from the following list (📖76).	
Display Channel	Sets the channel to assign to the CH button on the display.	
CH1	CH1 to CH20 (CH1)	Select a CH button and register a channel number. A list of settings under the menu [Channel Settings] (📖53) is displayed.
CH2	CH1 to CH20 (CH2)	
CH3	CH1 to CH20 (CH3)	
Language	English 日本語 简体中文	Sets the language of the OSD menu and messages.
Date/Time		Sets the year/month/date/hour/minute.
Network/Remote(GPI) Settings		
Network ¹	Configures settings for the network of the video display.	
Configure an IP Address	Automatic Manual	[Automatic]: Configures an IP address automatically with DHCP/Auto IP. [Manual]: Configure an IP address and subnet mask manually.
Display		192.168.0.1
Subnet Mask		255.255.255.0
In Monitor Display	The video display supports Television Systems Ltd.'s "TSL UMD Protocol Ver. 5.0". You can operate the video display using an external device connected to the LAN terminal and display characters and tally lights on the screen. You can specify the characters using up to 16 alpha-numerical characters and symbols. (📖35)	
Control	On , Off	Sets whether to receive the control signal from the connected device.
Position	Top Bottom	This sets whether the characters and tally lights will be displayed at the top or the bottom.

Sub Menu	Setting Options (Bold: factory default)	
Remote(GPI) ²	You can operate the video display using an external controller such as a switcher that has been connected to the REMOTE terminal. Operates while the GND (No. 8 Pin) is connected to No.s 1 to 7, shorting them.	
Pin1	CH1 to CH5	Assigns functions in each GPI pin. (☰34) • Combining [Tally Green] and [Tally Red] makes [Tally Amber].
Pin2	Aspect Marker ³ Safety Zone Marker 1/2 ³	
Pin3	Area Marker ³	
Pin4	Center Marker ³	
Pin5	Grid Marker ³ Time Code	
Pin6	Wave Form Monitor Vector Scope	
Pin7	Audio Level Meter Tally Green Tally Red Power On ⁴ — (Not set)	
Display Name	Sets the name of the main unit. You can input up to 16 alphanumeric characters.	
Power Indicator Brightness	Off 1 to 5 (3)	Adjusts the brightness of the power indicator on the main unit. The greater the number is, the greater the brightness.
Display Button LED	On , Off	Sets the F buttons and the lamp on the face.
Fan Settings	Sets the operation of internal fan.	
Fan Control	On , Off	Fan noise can be eliminated when the main unit is used during shooting or when silent operation is needed. Set this in advance to stop the fan manually or to stop the fan (☰69) by linking with the camera's REC signal. When this is set to [On], the mode changes so that the fan can be stopped.
Fan Stop ⁵	On , Off	If [Fan Stop] is set to [On] and when [Fan Control] is set to [On], the fan can be stopped. At room temperature (25 °C), the fan remains off for approximately one minute (about 10 minutes when using DC power). The fan operates at a faster speed than usual before and after the fan is stopped to lower the internal temperature.
Compatible Settings	Sets the connection compatibility with HDMI equipment.	
HDMI	Normal Compatible 1 Compatible 2	[Normal]: All formats are supported. [Compatible 1]: Set this option when video is not played correctly in [Normal]. HDR signals of a luminance higher than that of the display main unit are not supported. [Compatible 2]: Set this option when video is not played correctly in [Normal] or [Compatible 1]. [4K50.00P/60.00P] and HDR signals are not supported.

Sub Menu	Setting Options (Bold: factory default)	
Protect Settings	Locks the settings so they cannot be changed. When you press the MENU button, [Signal/System Information] appears, but other operations are grayed out because they are locked.	
Password		Set a password to protect settings. Use a four-digit number (0000 to 9999). The initial password is blank.
Protect Target		You can remove Picture Mode and Select Channel from the items to be protected.
Picture Mode	On , Off	[On]: Protects the [Picture Mode] settings. [Off]: Removes the [Picture Mode] settings from protect target.
Select Channel	On , Off	[On]: Protects the [Select Channel] settings. [Off]: Removes the [Select Channel] settings from protect target.
Protect		Select [OK] to protect. When a password has been set, enter the password and select [OK]. ❖ Unlocking Protect Settings Move the selection frame to [Protect] and press the Jog dial for approximately 3 seconds. When a password has been set, enter the password and select [OK].
Firmware Update	This function is used to update the video display firmware. Refer to the Canon website for detailed information.	
Export/Import ⁶	Sets the export/import main menu settings.	
Export		
Target	USB User 1 to User 3	Select the export destination. [USB]: Export to a USB memory. [User 1] to [User 3]: Export to the built-in memory of the main unit.
Filename		Factory default is "dinfo_dpv1710.dat". You can change the name of the file to be exported to the USB memory within 16 one-byte characters including alphabetical characters, numbers, and symbols.
Execute		Performs export.
Import		
Target	USB User 1 to User 3	Specify the destination to save the file to be imported.
Filename		Displays files with the extension ".dat" so you can select from among them.
Settings	All Adjustment Channel Settings Display Settings Audio Settings Marker Settings Function Settings System Settings	Select the settings to import.
Execute		Performs import.

Sub Menu	Setting Options (Bold: factory default)	
Power on Setting	Last memory User 1 to User 3	You can select the state of the display when the power is turned on. [Last memory]: The video display starts up with the settings last used. [User 1] to [User 3]: It starts up with the settings saved in [User 1] to [User 3] under [Export].
Reset All Settings	OK Cancel	Returns all settings to factory default. When selected, the message [Reset all settings to factory defaults?] appears. [OK]: Performs reset. [Cancel]: Returns to the previous screen without resetting.

¹ Cannot be set when [Power on Setting] is [User 1] to [User 3].

² This function will not work correctly in the following cases.

- If the same function is assigned to multiple pins.
- If the changes to the [Remote (GPI)] setting and the pin assignments were made when the pins were shorted.

³ The marker cannot be displayed when [Marker Preset] is set to [Off].

⁴ Can only be registered to [Pin7].

- ⁵
- If the message [Invalid operation due to high temperature.] is displayed, the fan cannot be stopped even when [On] is selected for this item. Wait until the internal temperature lowers.
 - If the temperature inside the main unit increases while the fan is off, the message [Fan will be rotated as the temperature is high.] is displayed and the fan starts rotating approximately ten seconds later. Since the temperature of the main unit has increased, the fan rotates faster than usual.
 - Select [Off] to restart the fan. The fan rotates faster than usual.
 - The fan may not stop in some conditions, for example when used at a high temperature.

⁶ • The following settings cannot be exported or imported.

Adjustment	Target values of Calibration (including calibration results)
Display Settings	Zoom Preset, Frame Hold
Function Settings	Test Pattern, Various Function (Monochrome, Blue Only, Red Off, Green Off, Blue Off)
System Settings	Date/Time, Fan Stop, Export/Import, Power on Setting

- User LUT data cannot be exported or imported to [User 1] to [User 3] under [Target].
- Data exported from this product may not be imported to products of which firmware version is earlier than the version of this product. To import data, update the firmware to the latest version.

■ Function to allow registration for the display F buttons (📖 72)

Item	Options	Item	Options
Adjustment	Picture Mode	Gamma	1.0
	Contrast		2.2
	Brightness		2.35
	Chroma		2.4
	Chroma up		2.6
	Sharpness		ITU-R BT.1886
	Backlight Control ¹		Canon Log
	Gamma		Canon Log (HDR)
	HDR		Canon Log 2
	HDR Range		Canon Log 2 (HDR)
	HDR/SDR View		Canon Log 3
	Gain		Canon Log 3 (HDR)
	Bias	SMPTE ST 2084	
	xy	Hybrid Log-Gamma Y	
	Picture Mode	SMPTE-C	Hybrid Log-Gamma RGB
EBU		Gamma LUT 1 to Gamma LUT 8	
ITU-R BT.709		CDL/User LUT	CDL Preset
ITU-R BT.2020			User LUT
Adobe RGB			CDL R
DCI-P3			CDL G
User 1 to User 7			CDL B
Canon Log			CDL Slope
ACESproxy			CDL Offset
Color Gamut			SMPTE-C
	EBU		CDL Saturation
	ITU-R BT.709		CDL SOP/SAT
	ITU-R BT.2020	CDL/User LUT Bypass	
	Adobe RGB	CDL Export/Import	
	DCI-P3	Channel Settings	Channel UP ²
	Native		Channel DOWN ²
	Cinema Gamut to 709		Select Input Signal
	Cinema Gamut to 2020		Audio Input
	Cinema Gamut to DCI		CH1 to CH20
	DCI-P3+ to 709		
	DCI-P3+ to DCI		
	DCI-P3 to 709		
	ITU-R BT.2020 to 709		
	ACESproxy		
Gamut LUT 1 to Gamut LUT 8			

Item	Options
Display Settings	Screen Scalling
	Scaling Method
	Zoom Preset
	Zoom 1
	Zoom 2
	Zoom 3
	Frame Hold
Audio Settings	SDI Group
	CH L
	CH R
	Volume
	Audio Switch
Marker Settings ³	Marker Preset
	Marker 1
	Marker 2
	Marker 3
	Marker 4
	Marker 5
	Aspect Marker
	Safety Zoon Marker 1
	Safety Zoon Marker 2
	Area Marker
	Center Marker
	Grid Marker

Item	Options
Function Settings	Peaking
	Peaking 1
	Peaking 2
	Flase Color
	Capture
	Time Code
	WFM/VEC
	Wave Form Monitor
	WFM Select Signal
	Vector Scope
	Audio Level Meter
	Monochrome
	Blue Only
Red Off	
Green Off	
Blue Off	
Camera Information	
System Settings	Hide OSD ⁴
	Fan Stop

¹ When the [Backlight Control] setting is switched using an F button, the information is applied to [Backlight Control] in [Picture Mode].

² When changing channels with [Channel UP/DOWN], the channels with [Input Configuration] ( 53) set to [-] are skipped.

³ When any marker settings are changed using an F button, those changes will be applied to [Enable] under the currently selected [Marker Preset].

⁴ [Hide OSD] is a function to hide all OSD. When [On] is selected, OSD and [Separator] are hidden but the menu can be used.

Signal Information

Shows the signal information. When [Select Input Signal] is [Quad Input], information for the entire signal and each input is displayed. Select a signal with the jog dial according to the guide at top right corner of the menu. When signal information has been obtained although it is not displayed on the screen, the content of the information is grayed out.

SDI Signal		HDMI Signal	
Item	Display Example	Item	Display Example
Channel	CH1	Channel	CH4
Input Configuration	6G/3G/HD-SDI (3G Level A)	Input Configuration	HDMI
Select Input Signal	Quad Input	Format	Automatic
Image Division	Automatic	Resolution	4096x2160
Format	Automatic	Picture Rate, I/P/PsF	60.00P
Resolution	4096x2160	Pixel Encoding, Color Depth	4:2:2 YCbCr 10-bit
Picture Rate, I/P/PsF*	24.00P	Matrix	ITU-R BT.709
SDI Payload ID	89 C3 46 01	Range	Full
Video Standard	3G-SDI	EOTF	SMPTE ST 2084
Sampling Structure	4:4:4:4 GBRA	Max Luminance (Peak/Avg.)	1000 / 500 cd/m ²
Bit Depth	10-bit	Display Luminance (Max/Min)	1000 - 0.005 cd/m ²
Picture Rate	24.00	White Point	x=0.313, y=0.329
Scanning Method	Progressive/Progressive (Transport/Picture)	Primary Color Red	x=0.640, y=0.330
		Primary Color Green	x=0.300, y=0.600
Link Number	Single/Link_1	Primary Color Blue	x=0.150, y=0.060

* When a content is grayed out, an asterisk [*] may be displayed indicating low [Picture Rate] accuracy such as [24.00P *].

System Information

Shows the video display status and network information.

Item	Display Example
Display	DP-V1710
Serial No.	000000000000
Firmware Ver.	1.0
Usage Time*	5 h
IP Address	192.168.0.1
Subnet Mask	255.255.255.0
MAC Address	FF:FF:FF:FF:FF:FF

* The [Usage Time] is not always [0] when you purchase the display due to factory inspection.

Main specifications/Performance

Panel		
Panel Type	IPS LCD panel	
Screen Size	17.3 inch (43.8 cm)	
Aspect Ratio	16:9	
Resolution	3840x2160 (8.3 megapixels)	
Active Display Area	Approximately 381.9 x 214.8 mm	
Pixel Pitch	99 µm/255 ppi	
Image quality		
Brightness (Standard)	100 cd/m ²	
View Angle (Up, Down, Left, Right)	89° (contrast ratio 10 : 1 or higher)	
Surface Treatment	Anti-glare coating	
General		
Backlight Type	LED, direct down type	
Power	Rated Voltage: 100 – 240 V AC Rated Frequency: 50/60 Hz 12 V DC Max. 10 A, XLR terminal	
Power consumption	At maximum load (including change in brightness through aging): Approximately 140 W At factory shipment: Approximately 85 W	
Environmental Conditions	Operating	Temperature and humidity: 0 – 40 °C (32 – 104 °F), 20 – 85 %RH (no condensation) recommended: 15 – 30 °C (59 – 86 °F) Pressure: 700 – 1060 hPa
	Storage/ Transporting	Temperature and humidity: -20 – 40 °C (-4 – 104 °F), 20 – 85 %RH (no condensation) 41 – 60 °C (105 – 140 °F), 20 – 30 %RH (no condensation) Pressure: 700 – 1060 hPa
Dimensions (width x height x depth)	Including stands and handle: Approx. 435x356x194 mm (17.1x14.0x7.6 in.) Main unit only, excluding protrusions: Approx. 435x308x154 mm (17.1x12.1x6.1 in.)	
Weight	Approximately 8 kg (17.6 lb)	
Mounting Hole Pitch	VESA standard 100 x 100 mm (3.9 x 3.9 in.)	

Interface		
Input	6G/3G/HD-SDI	4 (1 systems) BNC (75 Ω) receptacle terminal 6G-SDI: Compliant with SMPTE 2081 3G-SDI: Compliant with SMPTE 2048-2/274M/296/372/425-5/425-3/425-1/ 428-19/428-9 HD-SDI: Compliant with SMPTE 2048-2/274M/292-1/296/428-19/428-9
	HDMI	1 (1 system) type A terminal Contents protection standard: HDCP 2.2
Output	6G/3G/HD-SDI	4 (1 pass-thru systems)
	Head phone	1 stereo mini jack, Supported impedance: 32 Ω to 64 Ω
Others	USB	1 USB A receptacle terminal Universal Serial Bus Specification Revision 2.0 compliant LS (Low Speed)/FS (Full Speed)/HS (High Speed) mode compatible Compliant with Enhanced Host Controller Interface Specification for Universal Serial Bus Revision 1.0
	LAN	1 RJ-45 terminal Compliant with IEEE802.3 10BASE-TX/IEEE802.3u 100BASE-TX
	REMOTE	1 RJ-45 terminal, GPI 8 pins

Weight and dimensions are approximate. Error and omissions excepted.

The information in this manual is verified as of December 2016. It is subject to change without notice.

Dimensions

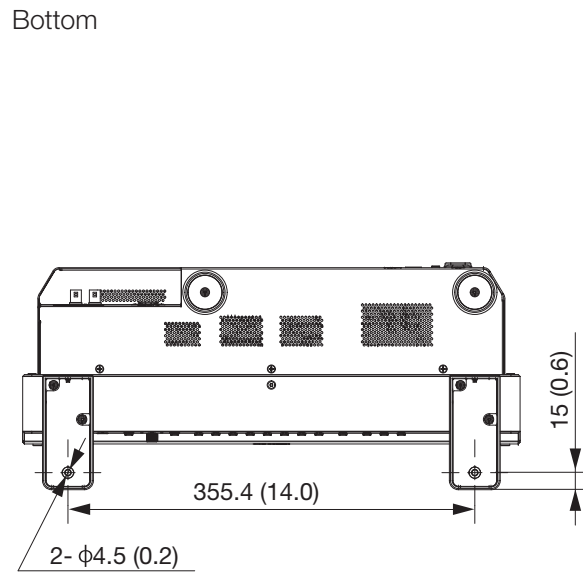
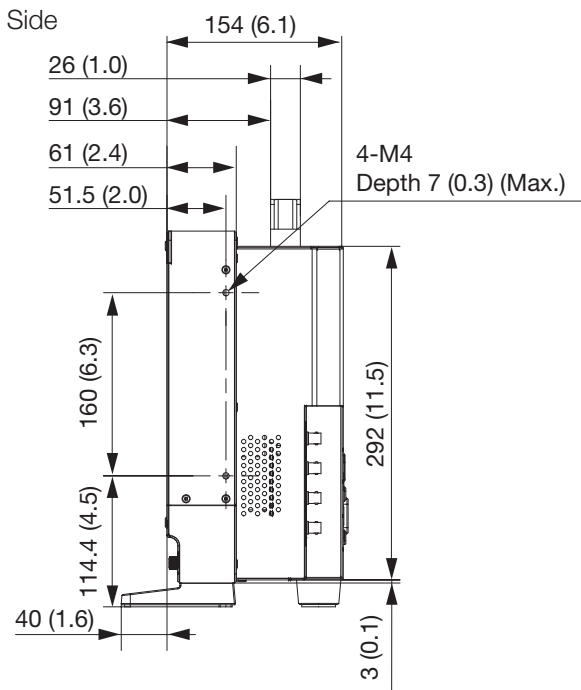
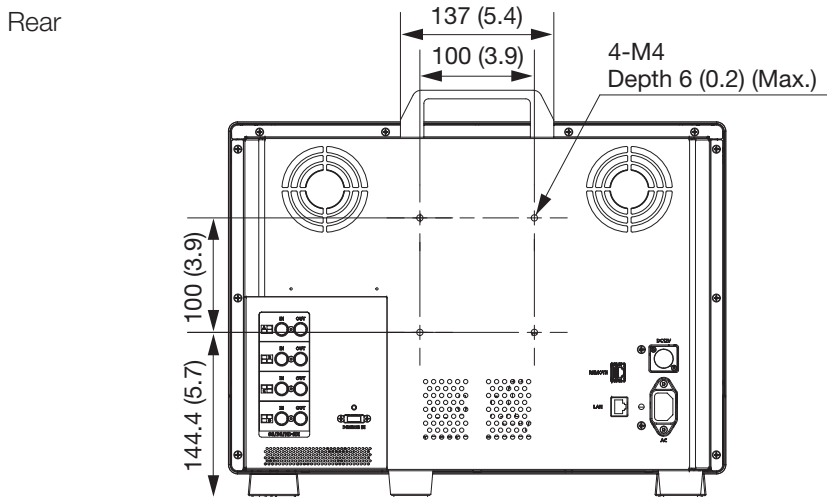
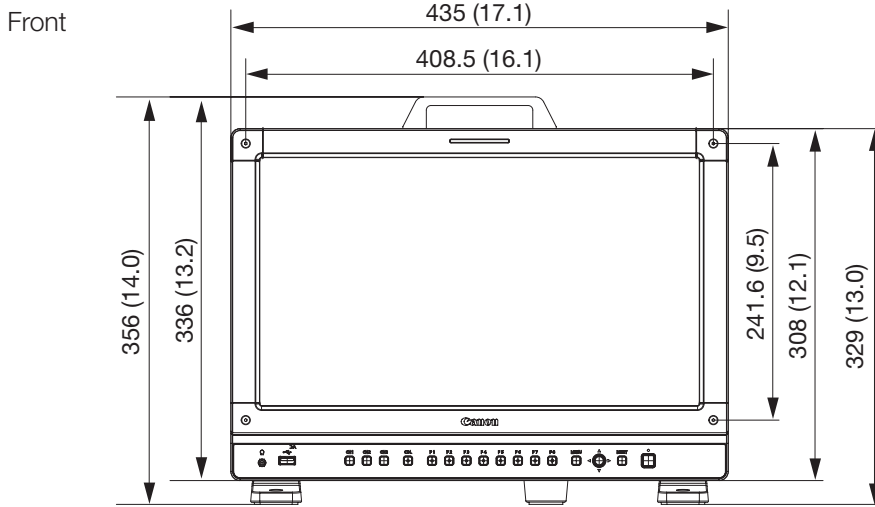

Unit: mm (inch)

82 Supported Signal Format

SDI

Transmission method	Signal format	Color format	Color depth	Standards
HD-SDI	1280x720P 59.94/60.00 Hz	4:2:2 YCbCr	10-bit	SMPTE 292-1 SMPTE 296
	1280x720P 50.00 Hz			
	1280x720P 29.97/30.00 Hz			
	1280x720P 25.00 Hz			
	1280x720P 23.98/24.00 Hz			
	1920x1080i 59.94/60.00 Hz			
	1920x1080i 50.00 Hz			
	1920x1080P 29.97/30.00 Hz			
	1920x1080PsF 29.97/30.00 Hz			
	1920x1080P 25.00 Hz			
	1920x1080PsF 25.00 Hz			
	1920x1080P 23.98/24.00 Hz			SMPTE 292-1 SMPTE 428-9 SMPTE 428-19 SMPTE 2048-2
	1920x1080PsF 23.98/24.00 Hz			
	2048x1080i 59.94/60.00 Hz			
	2048x1080i 50.00 Hz			
	2048x1080P 29.97/30.00 Hz			
	2048x1080PsF 29.97/30.00 Hz			
	2048x1080P 25.00 Hz			SMPTE 292-1 SMPTE 428-9 SMPTE 428-19 SMPTE 2048-2
	2048x1080PsF 25.00 Hz			
	2048x1080P 23.98/24.00 Hz			
2048x1080PsF 23.98/24.00 Hz				
3G-SDI (Level A)	1280x720P 59.94/60.00 Hz	4:4:4 RGB 4:4:4 YCbCr	10-bit	SMPTE 425-1 SMPTE 296
	1280x720P 50.00 Hz	4:4:4 RGB 4:4:4 YCbCr	10-bit	
	1280x720P 29.97/30.00 Hz	4:4:4 RGB 4:4:4 YCbCr	10-bit	
	1280x720P 25.00 Hz	4:4:4 RGB 4:4:4 YCbCr	10-bit	
	1280x720P 23.98/24.00 Hz	4:4:4 RGB 4:4:4 YCbCr	10-bit	
	1920x1080P 59.94/60.00 Hz	4:2:2 YCbCr	10-bit	

Transmission method	Signal format	Color format	Color depth	Standards
3G-SDI (Level A)	1920x1080i 59.94/60.00 Hz	4:4:4 RGB	12-bit/10-bit	SMPTE 425-1 SMPTE 274M
		4:4:4 YCbCr		
	1920x1080P 50.00 Hz	4:2:2 YCbCr	12-bit	
		4:2:2 YCbCr	10-bit	
	1920x1080i 50.00 Hz	4:4:4 RGB	12-bit/10-bit	
		4:4:4 YCbCr		
	1920x1080P 29.97/30.00 Hz	4:2:2 YCbCr	12-bit	
		4:2:2 YCbCr	12-bit	
	1920x1080P 29.97/30.00 Hz	4:4:4 RGB	10-bit	
		4:4:4 RGB	12-bit	
	1920x1080PsF 29.97/30.00 Hz	4:4:4 YCbCr	12-bit	
		4:4:4 YCbCr	10-bit	
	1920x1080P 25.00 Hz	4:2:2 YCbCr	12-bit	SMPTE 425-1 SMPTE 274M
		4:2:2 YCbCr	12-bit	
	1920x1080PsF 25.00 Hz	4:4:4 RGB	10-bit	
		4:4:4 RGB	12-bit	
	1920x1080P 25.00 Hz	4:4:4 YCbCr	12-bit	SMPTE 425-1 SMPTE 274M
		4:4:4 YCbCr	10-bit	
	1920x1080PsF 25.00 Hz	4:2:2 YCbCr	12-bit	
		4:2:2 YCbCr	12-bit	
1920x1080P 23.98/24.00 Hz	4:4:4 RGB	10-bit	SMPTE 425-1 SMPTE 274M	
	4:4:4 RGB	12-bit		
1920x1080PsF 23.98/24.00 Hz	4:4:4 YCbCr	12-bit		
	4:4:4 YCbCr	10-bit		
1920x1080P 23.98/24.00 Hz	4:2:2 YCbCr	12-bit	SMPTE 425-1 SMPTE 274M	
	4:2:2 YCbCr	12-bit		
2048x1080P 59.94/60.00 Hz	4:4:4 RGB	10-bit	SMPTE 425-1 SMPTE 428-9 SMPTE 428-19 SMPTE 2048-2	
2048x1080i 59.94/60.00 Hz	4:2:2 YCbCr	10-bit		
2048x1080P 50.00 Hz	4:4:4 RGB	12-bit/10-bit		
	4:4:4 YCbCr			
2048x1080P 50.00 Hz	4:4:4 X'Y'Z'	12-bit		
	4:2:2 YCbCr	12-bit		
2048x1080P 50.00 Hz	4:2:2 YCbCr	10-bit	SMPTE 425-1 SMPTE 2048-2	

Transmission method	Signal format	Color format	Color depth	Standards	
3G-SDI (Level A)	2048x1080i 50.00 Hz	4:4:4 RGB	12-bit/10-bit		
		4:4:4 YCbCr	12-bit		
		4:4:4 X'Y'Z'			
		4:2:2 YCbCr			
		2048x1080P 47.95/48.00 Hz	4:2:2 YCbCr	10-bit	SMPTE 425-1 SMPTE 2048-2
		2048x1080P 29.97/30.00 Hz	4:4:4 RGB	12-bit/10-bit	SMPTE 425-1 SMPTE 428-9 SMPTE 428-19 SMPTE 2048-2
	4:4:4 X'Y'Z'		12-bit		
	4:4:4 YCbCr		12-bit/10-bit	SMPTE 425-1 SMPTE 2048-2	
	4:2:2 YCbCr		12-bit		
		2048x1080PsF 29.97/30.00 Hz	4:4:4 RGB	12-bit/10-bit	SMPTE 425-1 SMPTE 428-9 SMPTE 428-19 SMPTE 2048-2
	4:4:4 X'Y'Z'		12-bit		
	4:4:4 YCbCr		12-bit/10-bit	SMPTE 425-1 SMPTE 2048-2	
	4:2:2 YCbCr		12-bit		
		2048x1080P 25.00 Hz	4:4:4 RGB	12-bit/10-bit	SMPTE 425-1 SMPTE 428-9 SMPTE 428-19 SMPTE 2048-2
	4:4:4 X'Y'Z'		12-bit		
	4:4:4 YCbCr		12-bit/10-bit	SMPTE 425-1 SMPTE 2048-2	
	4:2:2 YCbCr		12-bit		
		2048x1080PsF 25.00 Hz	4:4:4 RGB	12-bit/10-bit	SMPTE 425-1 SMPTE 428-9 SMPTE 428-19 SMPTE 2048-2
	4:4:4 X'Y'Z'		12-bit		
	4:4:4 YCbCr		12-bit/10-bit	SMPTE 425-1 SMPTE 2048-2	
4:2:2 YCbCr	12-bit				
	2048x1080P 23.98/24.00 Hz	4:4:4 RGB	12-bit/10-bit	SMPTE 425-1 SMPTE 428-9 SMPTE 428-19 SMPTE 2048-2	
4:4:4 X'Y'Z'		12-bit			
4:4:4 YCbCr		12-bit/10-bit	SMPTE 425-1 SMPTE 2048-2		
4:2:2 YCbCr		12-bit			
	2048x1080PsF 23.98/24.00 Hz	4:4:4 RGB	12-bit/10-bit	SMPTE 425-1 SMPTE 428-9 SMPTE 428-19 SMPTE 2048-2	
4:4:4 X'Y'Z'		12-bit			
4:4:4 YCbCr		12-bit/10-bit	SMPTE 425-1 SMPTE 2048-2		
4:2:2 YCbCr		12-bit			

Transmission method	Signal format	Color format	Color depth	Standards
3G-SDI (Level B)	1920x1080P 59.94/60.00 Hz	4:2:2 YCbCr	10-bit	SMPTE 425-1 SMPTE 372 SMPTE 274M
	1920x1080i 59.94/60.00 Hz	4:4:4 RGB 4:4:4 YCbCr	12-bit/10-bit	
		4:2:2 YCbCr	12-bit	
	1920x1080P 50.00 Hz	4:2:2 YCbCr	10-bit	
	1920x1080i 50.00 Hz	4:4:4 RGB 4:4:4 YCbCr	12-bit/10-bit	
		4:2:2 YCbCr	12-bit	
	1920x1080P 29.97/30.00 Hz	4:4:4 RGB 4:4:4 YCbCr	12-bit/10-bit	
		4:2:2 YCbCr	12-bit	
	1920x1080PsF 29.97/30.00 Hz	4:4:4 RGB 4:4:4 YCbCr	12-bit/10-bit	
		4:2:2 YCbCr	12-bit	
	1920x1080P 25.00 Hz	4:4:4 RGB 4:4:4 YCbCr	12-bit/10-bit	
		4:2:2 YCbCr	12-bit	
	1920x1080PsF 25.00 Hz	4:4:4 RGB 4:4:4 YCbCr	12-bit/10-bit	
		4:2:2 YCbCr	12-bit	
	1920x1080P 23.98/24.00 Hz	4:4:4 RGB 4:4:4 YCbCr	12-bit/10-bit	
		4:2:2 YCbCr	12-bit	
	1920x1080PsF 23.98/24.00 Hz	4:4:4 RGB 4:4:4 YCbCr	12-bit/10-bit	
		4:2:2 YCbCr	12-bit	
	2048x1080P 59.94/60.00 Hz	4:2:2 YCbCr	10-bit	SMPTE 425-1 SMPTE 372 SMPTE 428-9 SMPTE 428-19 SMPTE 2048-2
	2048x1080i 59.94/60.00 Hz	4:4:4 RGB 4:4:4 YCbCr	12-bit/10-bit	
4:4:4 X'Y'Z' 4:2:2 YCbCr		12-bit		
2048x1080P 50.00 Hz	4:2:2 YCbCr	10-bit	SMPTE 425-1 SMPTE 372 SMPTE 2048-2	
2048x1080i 50.00 Hz	4:4:4 RGB 4:4:4 YCbCr	12-bit/10-bit		
	4:4:4 X'Y'Z' 4:2:2 YCbCr	12-bit		

Transmission method	Signal format	Color format	Color depth	Standards
3G-SDI (Level B)	2048x1080P 47.95/48.00 Hz	4:2:2 YCbCr	10-bit	SMPTE 425-1 SMPTE 372 SMPTE 2048-2
		4:4:4 RGB	12-bit/10-bit	SMPTE 425-1 SMPTE 372 SMPTE 428-9 SMPTE 428-19 SMPTE 2048-2
	2048x1080P 29.97/30.00 Hz	4:4:4 X'Y'Z'	12-bit	SMPTE 425-1 SMPTE 372 SMPTE 428-9 SMPTE 428-19 SMPTE 2048-2
		4:4:4 YCbCr	12-bit/10-bit	SMPTE 425-1 SMPTE 372 SMPTE 2048-2
		4:2:2 YCbCr	12-bit	SMPTE 425-1 SMPTE 372 SMPTE 2048-2
		4:4:4 RGB	12-bit/10-bit	SMPTE 425-1 SMPTE 372 SMPTE 428-9 SMPTE 428-19 SMPTE 2048-2
	2048x1080PsF 29.97/30.00 Hz	4:4:4 X'Y'Z'	12-bit	SMPTE 425-1 SMPTE 372 SMPTE 428-9 SMPTE 428-19 SMPTE 2048-2
		4:4:4 YCbCr	12-bit/10-bit	SMPTE 425-1 SMPTE 372 SMPTE 2048-2
		4:2:2 YCbCr	12-bit	SMPTE 425-1 SMPTE 372 SMPTE 2048-2
		4:4:4 RGB	12-bit/10-bit	SMPTE 425-1 SMPTE 372 SMPTE 428-9 SMPTE 428-19 SMPTE 2048-2
	2048x1080P 25.00 Hz	4:4:4 X'Y'Z'	12-bit	SMPTE 425-1 SMPTE 372 SMPTE 428-9 SMPTE 428-19 SMPTE 2048-2
		4:4:4 YCbCr	12-bit/10-bit	SMPTE 425-1 SMPTE 372 SMPTE 2048-2
		4:2:2 YCbCr	12-bit	SMPTE 425-1 SMPTE 372 SMPTE 2048-2
		4:4:4 RGB	12-bit/10-bit	SMPTE 425-1 SMPTE 372 SMPTE 428-9 SMPTE 428-19 SMPTE 2048-2
	2048x1080PsF 25.00 Hz	4:4:4 X'Y'Z'	12-bit	SMPTE 425-1 SMPTE 372 SMPTE 428-9 SMPTE 428-19 SMPTE 2048-2
		4:4:4 YCbCr	12-bit/10-bit	SMPTE 425-1 SMPTE 372 SMPTE 2048-2
		4:2:2 YCbCr	12-bit	SMPTE 425-1 SMPTE 372 SMPTE 2048-2
		4:4:4 RGB	12-bit/10-bit	SMPTE 425-1 SMPTE 372 SMPTE 428-9 SMPTE 428-19 SMPTE 2048-2
	2048x1080P 23.98/24.00 Hz	4:4:4 X'Y'Z'	12-bit	SMPTE 425-1 SMPTE 372 SMPTE 428-9 SMPTE 428-19 SMPTE 2048-2
		4:4:4 YCbCr	12-bit/10-bit	SMPTE 425-1 SMPTE 372 SMPTE 2048-2
4:2:2 YCbCr		12-bit	SMPTE 425-1 SMPTE 372 SMPTE 2048-2	
4:4:4 RGB		12-bit/10-bit	SMPTE 425-1 SMPTE 372 SMPTE 428-9 SMPTE 428-19 SMPTE 2048-2	

Transmission method	Signal format	Color format	Color depth	Standards
3G-SDI (Level B)	2048x1080PsF 23.98/24.00 Hz	4:4:4 RGB	12-bit/10-bit	SMPTE 425-1 SMPTE 372 SMPTE 428-9 SMPTE 428-19 SMPTE 2048-2
		4:4:4 X'Y'Z'	12-bit	
		4:4:4 YCbCr	12-bit/10-bit	SMPTE 425-1 SMPTE 372 SMPTE 2048-2
		4:2:2 YCbCr	12-bit	
Dual Link 3G-SDI (Level A)	1920x1080P 59.94/60 Hz	4:4:4 RGB	12-bit/10-bit	SMPTE 425-3 SMPTE 274M
		4:4:4 YCbCr		
		4:2:2 YCbCr	12-bit	
	1920x1080P 50 Hz	4:4:4 RGB	12-bit/10-bit	
		4:4:4 YCbCr		
		4:2:2 YCbCr	12-bit	
	2048x1080P 59.94/60 Hz	4:4:4 RGB	12-bit/10-bit	SMPTE 425-3 SMPTE 428-9 SMPTE 428-19 SMPTE 2048-2
		4:4:4 YCbCr		
		4:4:4 X'Y'Z'	12-bit	
	4:2:2 YCbCr			
	2048x1080P 50 Hz	4:4:4 RGB	12-bit/10-bit	
		4:4:4 YCbCr		
4:4:4 X'Y'Z'		12-bit		
4:2:2 YCbCr				
2048x1080P 47.95/48 Hz	4:4:4 RGB	12-bit/10-bit		
	4:4:4 YCbCr			
	4:4:4 X'Y'Z'	12-bit		
4:2:2 YCbCr				
Dual Link 3G-SDI (Level B)	1920x1080P 59.94/60 Hz	4:4:4 RGB	12-bit/10-bit	SMPTE 425-3 SMPTE 372 SMPTE 274M
		4:4:4 YCbCr		
		4:2:2 YCbCr	12-bit	
	1920x1080P 50 Hz	4:4:4 RGB	12-bit/10-bit	
		4:4:4 YCbCr		
		4:2:2 YCbCr	12-bit	
	2048x1080P 59.94/60 Hz	4:4:4 RGB	12-bit/10-bit	SMPTE 425-3 SMPTE 372 SMPTE 428-9 SMPTE 428-19 SMPTE 2048-2
		4:4:4 YCbCr		
		4:4:4 X'Y'Z'	12-bit	
	4:2:2 YCbCr			
	2048x1080P 50 Hz	4:4:4 RGB	12-bit/10-bit	
		4:4:4 YCbCr		
4:4:4 X'Y'Z'		12-bit		
4:2:2 YCbCr				
2048x1080P 47.95/48 Hz	4:4:4 RGB	12-bit/10-bit		
	4:4:4 YCbCr			
	4:4:4 X'Y'Z'	12-bit		
4:2:2 YCbCr				

Transmission method	Signal format	Color format	Color depth	Standards
Dual Link 3G-SDI Square Division (Level B)	3840x2160P 29.97/30 Hz	4:2:2 YCbCr	10-bit	SMPTE 425-3 SMPTE 372 SMPTE 274M
	3840x2160PsF 29.97/30 Hz			
	3840x2160P 25 Hz			
	3840x2160PsF 25 Hz			
	3840x2160P 23.98/24 Hz			
	3840x2160PsF 23.98/24 Hz			
	4096x2160P 29.97/30 Hz			SMPTE 425-3 SMPTE 372 SMPTE 2048-2
	4096x2160PsF 29.97/30 Hz			
	4096x2160P 25 Hz			
	4096x2160PsF 25 Hz			
	4096x2160P 23.98/24 Hz			
	4096x2160PsF 23.98/24 Hz			
Dual Link 3G-SDI 2 Sample Interleave (Level B)	3840x2160P 29.97/30 Hz	4:2:2 YCbCr	10-bit	SMPTE 425-3 SMPTE 372 SMPTE 274M
	3840x2160P 25 Hz			
	3840x2160P 23.98/24 Hz			
	4096x2160P 29.97/30 Hz			SMPTE 425-3 SMPTE 372 SMPTE 2048-2
	4096x2160P 25 Hz			
	4096x2160P 23.98/24 Hz			
Quad Link HD-SDI	3840x2160i 59.94/60.00 Hz	4:2:2 YCbCr	10-bit	SMPTE 292-1 SMPTE 274M
	3840x2160i 50.00 Hz			
	3840x2160P 29.97/30.00 Hz			
	3840x2160PsF 29.97/30.00 Hz			
	3840x2160P 25.00 Hz			
	3840x2160PsF 25.00 Hz			
	3840x2160P 23.98/24.00 Hz			
	3840x2160PsF 23.98/24.00 Hz			
	4096x2160i 59.94/60.00 Hz			SMPTE 292-1 SMPTE 428-9 SMPTE 428-19 SMPTE 2048-2
	4096x2160i 50.00 Hz			
	4096x2160P 29.97/30.00 Hz			
	4096x2160PsF 29.97/30.00 Hz			
	4096x2160P 25.00 Hz			
	4096x2160PsF 25.00 Hz			
	4096x2160P 23.98/24.00 Hz			
	4096x2160PsF 23.98/24.00 Hz			

Transmission method	Signal format	Color format	Color depth	Standards
Quad Link 3G-SDI (Level A)	3840x2160P 59.94/60.00 Hz	4:2:2 YCbCr	10-bit	SMPTE 425-1 SMPTE 274M
	3840x2160i 59.94/60.00 Hz	4:4:4 RGB 4:4:4 YCbCr	12-bit/10-bit	
		4:2:2 YCbCr	12-bit	
	3840x2160P 50.00 Hz	4:2:2 YCbCr	12-bit	
	3840x2160i 50.00 Hz	4:4:4 RGB 4:4:4 YCbCr	12-bit/10-bit	
		4:2:2 YCbCr	12-bit	
	3840x2160P 29.97/30.00 Hz	4:4:4 RGB 4:4:4 YCbCr	12-bit/10-bit	
		4:2:2 YCbCr	12-bit	
	3840x2160PsF 29.97/30.00 Hz	4:4:4 RGB	10-bit	
			12-bit	
		4:4:4 YCbCr	12-bit	
		4:4:4 YCbCr	10-bit	SMPTE 425-1 SMPTE 274M
		4:2:2 YCbCr	12-bit	
	3840x2160P 25.00 Hz	4:4:4 RGB 4:4:4 YCbCr	12-bit/10-bit	
		4:2:2 YCbCr	12-bit	
	3840x2160PsF 25.00 Hz	4:4:4 RGB	10-bit	
			12-bit	
		4:4:4 YCbCr	12-bit	
		4:4:4 YCbCr	10-bit	SMPTE 425-1 SMPTE 274M
		4:2:2 YCbCr	12-bit	
3840x2160P 23.98/24.00 Hz	4:4:4 RGB 4:4:4 YCbCr	12-bit/10-bit		
	4:2:2 YCbCr	12-bit		
3840x2160PsF 23.98/24.00 Hz	4:4:4 RGB	10-bit		
		12-bit		
	4:4:4 YCbCr	12-bit		
	4:4:4 YCbCr	10-bit	SMPTE 425-1 SMPTE 274M	
	4:2:2 YCbCr	12-bit		
4096x2160P 59.94/60.00 Hz	4:2:2 YCbCr	10-bit	SMPTE 425-1 SMPTE 428-9 SMPTE 428-19 SMPTE 2048-2	
4096x2160i 59.94/60.00 Hz	4:4:4 RGB 4:4:4 YCbCr	12-bit/10-bit		
	4:4:4 X'Y'Z' 4:2:2 YCbCr	12-bit		

Transmission method	Signal format	Color format	Color depth	Standards
Quad Link 3G-SDI (Level A)	4096x2160P 50.00 Hz	4:2:2 YCbCr	10-bit	SMPTE 425-1 SMPTE 2048-2
	4096x2160i 50.00 Hz	4:4:4 RGB 4:4:4 YCbCr	12-bit/10-bit	
		4:4:4 X'Y'Z' 4:2:2 YCbCr	12-bit	
	4096x2160P 47.95/48.00 Hz	4:2:2 YCbCr	10-bit	SMPTE 425-1 SMPTE 2048-2
	4096x2160P 29.97/30.00 Hz	4:4:4 RGB	12-bit/10-bit	SMPTE 425-1 SMPTE 428-9 SMPTE 428-19 SMPTE 2048-2
		4:4:4 X'Y'Z'	12-bit	
		4:4:4 YCbCr	12-bit/10-bit	SMPTE 425-1 SMPTE 2048-2
		4:2:2 YCbCr	12-bit	
	4096x2160PsF 29.97/30.00 Hz	4:4:4 RGB	12-bit/10-bit	SMPTE 425-1 SMPTE 428-9 SMPTE 428-19 SMPTE 2048-2
		4:4:4 X'Y'Z'	12-bit	
		4:4:4 YCbCr	12-bit/10-bit	SMPTE 425-1 SMPTE 2048-2
		4:2:2 YCbCr	12-bit	
	4096x2160P 25.00 Hz	4:4:4 RGB	12-bit/10-bit	SMPTE 425-1 SMPTE 428-9 SMPTE 428-19 SMPTE 2048-2
		4:4:4 X'Y'Z'	12-bit	
		4:4:4 YCbCr	12-bit/10-bit	SMPTE 425-1 SMPTE 2048-2
		4:2:2 YCbCr	12-bit	
	4096x2160PsF 25.00 Hz	4:4:4 RGB	12-bit/10-bit	SMPTE 425-1 SMPTE 428-9 SMPTE 428-19 SMPTE 2048-2
		4:4:4 X'Y'Z'	12-bit	
		4:4:4 YCbCr	12-bit/10-bit	SMPTE 425-1 SMPTE 2048-2
		4:2:2 YCbCr	12-bit	
4096x2160P 23.98/24.00 Hz	4:4:4 RGB	12-bit/10-bit	SMPTE 425-1 SMPTE 428-9 SMPTE 428-19 SMPTE 2048-2	
	4:4:4 X'Y'Z'	12-bit		
	4:4:4 YCbCr	12-bit/10-bit	SMPTE 425-1 SMPTE 2048-2	
	4:2:2 YCbCr	12-bit		
4096x2160PsF 23.98/24.00 Hz	4:4:4 RGB	12-bit/10-bit	SMPTE 425-1 SMPTE 428-9 SMPTE 428-19 SMPTE 2048-2	
	4:4:4 X'Y'Z'	12-bit		
	4:4:4 YCbCr	12-bit/10-bit	SMPTE 425-1 SMPTE 2048-2	
	4:2:2 YCbCr	12-bit		

Transmission method	Signal format	Color format	Color depth	Standards
Quad Link 3G-SDI 2 Sample Interleave (Level A)	3840x2160P 59.94/60 Hz	4:2:2 YCbCr	10-bit	SMPTE 425-5 SMPTE 274M
	3840x2160P 50 Hz	4:2:2 YCbCr	10-bit	
	3840x2160P 29.97/30 Hz	4:4:4 RGB	12-bit/10-bit	
		4:4:4 YCbCr	12-bit	
	3840x2160P 25 Hz	4:2:2 YCbCr	12-bit	
		4:4:4 RGB	12-bit/10-bit	
	3840x2160P 23.98/24 Hz	4:4:4 YCbCr	12-bit/10-bit	
		4:2:2 YCbCr	12-bit	
	4096x2160P 59.94/60 Hz	4:2:2 YCbCr	10-bit	SMPTE 425-5 SMPTE 428-9 SMPTE 428-19 SMPTE 2048-2
	4096x2160P 50 Hz	4:2:2 YCbCr	10-bit	
	4096x2160P 47.95/48 Hz	4:2:2 YCbCr	10-bit	
	4096x2160P 29.97/30 Hz	4:4:4 RGB	12-bit/10-bit	
		4:4:4 X'Y'Z'	12-bit	
		4:4:4 YCbCr	12-bit/10-bit	
4:2:2 YCbCr		12-bit		
4096x2160P 25 Hz	4:4:4 RGB	12-bit/10-bit		
	4:4:4 X'Y'Z'	12-bit		
	4:4:4 YCbCr	12-bit/10-bit		
	4:2:2 YCbCr	12-bit		
4096x2160P 23.98/24 Hz	4:4:4 RGB	12-bit/10-bit		
	4:4:4 X'Y'Z'	12-bit		
	4:4:4 YCbCr	12-bit/10-bit		
	4:2:2 YCbCr	12-bit		
Quad Link 3G-SDI (Level B)	3840x2160P 59.94/60.00 Hz	4:2:2 YCbCr	10-bit	SMPTE 425-1 SMPTE 372 SMPTE 274M
	3840x2160i 59.94/60.00 Hz	4:4:4 RGB	12-bit/10-bit	
		4:4:4 YCbCr	12-bit	
	3840x2160P 50.00 Hz	4:2:2 YCbCr	10-bit	

Transmission method	Signal format	Color format	Color depth	Standards	
Quad Link 3G-SDI (Level B)	3840x2160i 50.00 Hz	4:4:4 RGB 4:4:4 YCbCr	12-bit/10-bit	SMPTE 425-1 SMPTE 372 SMPTE 274M	
		4:2:2 YCbCr	12-bit		
	3840x2160P 29.97/30.00 Hz	4:4:4 RGB 4:4:4 YCbCr	12-bit/10-bit		
		4:2:2 YCbCr	12-bit		
	3840x2160PsF 29.97/30.00 Hz	4:4:4 RGB 4:4:4 YCbCr	12-bit/10-bit		
		4:2:2 YCbCr	12-bit		
	3840x2160P 25.00 Hz	4:4:4 RGB 4:4:4 YCbCr	12-bit/10-bit		
		4:2:2 YCbCr	12-bit		
	3840x2160PsF 25.00 Hz	4:4:4 RGB 4:4:4 YCbCr	12-bit/10-bit		
		4:2:2 YCbCr	12-bit		
	3840x2160P 23.98/24.00 Hz	4:4:4 RGB 4:4:4 YCbCr	12-bit/10-bit		
		4:2:2 YCbCr	12-bit		
	3840x2160PsF 23.98/24.00 Hz	4:4:4 RGB 4:4:4 YCbCr	12-bit/10-bit		
		4:2:2 YCbCr	12-bit		
	4096x2160P 59.94/60.00 Hz	4:2:2 YCbCr	10-bit		SMPTE 425-1 SMPTE 372 SMPTE 428-9 SMPTE 428-19 SMPTE 2048-2
	4096x2160i 59.94/60.00 Hz	4:4:4 RGB 4:4:4 YCbCr	12-bit/10-bit		
4:4:4 X'Y'Z' 4:2:2 YCbCr		12-bit			
4096x2160P 50.00 Hz	4:2:2 YCbCr	10-bit	SMPTE 425-1 SMPTE 372 SMPTE 2048-2		
4096x2160i 50.00 Hz	4:4:4 RGB 4:4:4 YCbCr	12-bit/10-bit			
	4:4:4 X'Y'Z' 4:2:2 YCbCr	12-bit			
4096x2160P 47.95/48.00 Hz	4:2:2 YCbCr	10-bit	SMPTE 425-1 SMPTE 372 SMPTE 2048-2		

Transmission method	Signal format	Color format	Color depth	Standards
Quad Link 3G-SDI (Level B)	4096x2160P 29.97/30.00 Hz	4:4:4 RGB	12-bit/10-bit	SMPTE 425-1 SMPTE 372
		4:4:4 X'Y'Z'	12-bit	SMPTE 428-9 SMPTE 428-19 SMPTE 2048-2
		4:4:4 YCbCr	12-bit/10-bit	SMPTE 425-1 SMPTE 372
		4:2:2 YCbCr	12-bit	SMPTE 2048-2
	4096x2160PsF 29.97/30.00 Hz	4:4:4 RGB	12-bit/10-bit	SMPTE 425-1 SMPTE 372
		4:4:4 X'Y'Z'	12-bit	SMPTE 428-9 SMPTE 428-19 SMPTE 2048-2
		4:4:4 YCbCr	12-bit/10-bit	SMPTE 425-1 SMPTE 372
		4:2:2 YCbCr	12-bit	SMPTE 2048-2
	4096x2160P 25.00 Hz	4:4:4 RGB	12-bit/10-bit	SMPTE 425-1 SMPTE 372
		4:4:4 X'Y'Z'	12-bit	SMPTE 428-9 SMPTE 428-19 SMPTE 2048-2
		4:4:4 YCbCr	12-bit/10-bit	SMPTE 425-1 SMPTE 372
		4:2:2 YCbCr	12-bit	SMPTE 2048-2
4096x2160PsF 25.00 Hz	4:4:4 RGB	12-bit/10-bit	SMPTE 425-1 SMPTE 372	
	4:4:4 X'Y'Z'	12-bit	SMPTE 428-9 SMPTE 428-19 SMPTE 2048-2	
	4:4:4 YCbCr	12-bit/10-bit	SMPTE 425-1 SMPTE 372	
	4:2:2 YCbCr	12-bit	SMPTE 2048-2	
4096x2160P 23.98/24.00 Hz	4:4:4 RGB	12-bit/10-bit	SMPTE 425-1 SMPTE 372	
	4:4:4 X'Y'Z'	12-bit	SMPTE 428-9 SMPTE 428-19 SMPTE 2048-2	
	4:4:4 YCbCr	12-bit/10-bit	SMPTE 425-1 SMPTE 372	
	4:2:2 YCbCr	12-bit	SMPTE 2048-2	

Transmission method	Signal format	Color format	Color depth	Standards
Quad Link 3G-SDI (Level B)	4096x2160PsF 23.98/24.00 Hz	4:4:4 RGB	12-bit/10-bit	SMPTE 425-1 SMPTE 372 SMPTE 428-9 SMPTE 428-19 SMPTE 2048-2
		4:4:4 X'Y'Z'	12-bit	
		4:4:4 YCbCr	12-bit/10-bit	SMPTE 425-1 SMPTE 372 SMPTE 2048-2
		4:2:2 YCbCr	12-bit	
Quad Link 3G-SDI 2 Sample Interleave (Level B)	3840x2160P 59.94/60 Hz	4:2:2 YCbCr	10-bit	SMPTE 425-5 SMPTE 372 SMPTE 274M
	3840x2160P 50 Hz	4:2:2 YCbCr	10-bit	
	3840x2160P 29.97/30 Hz	4:4:4 RGB	12-bit/10-bit	
		4:4:4 YCbCr	12-bit	
	3840x2160P 25 Hz	4:4:4 RGB	12-bit/10-bit	
		4:4:4 YCbCr	12-bit	
	3840x2160P 23.98/24 Hz	4:4:4 RGB	12-bit/10-bit	
		4:4:4 YCbCr	12-bit	
	4096x2160P 59.94/60 Hz	4:2:2 YCbCr	10-bit	SMPTE 425-5 SMPTE 372 SMPTE 428-9 SMPTE 428-19 SMPTE 2048-2
	4096x2160P 50 Hz	4:2:2 YCbCr	10-bit	
	4096x2160P 47.95/48 Hz	4:2:2 YCbCr	10-bit	
	4096x2160P 29.97/30 Hz	4:4:4 RGB	12-bit/10-bit	
		4:4:4 X'Y'Z'	12-bit	
		4:4:4 YCbCr	12-bit/10-bit	
		4:2:2 YCbCr	12-bit	
	4096x2160P 25 Hz	4:4:4 RGB	12-bit/10-bit	
		4:4:4 X'Y'Z'	12-bit	
		4:4:4 YCbCr	12-bit/10-bit	
		4:2:2 YCbCr	12-bit	
	4096x2160P 23.98/24 Hz	4:4:4 RGB	12-bit/10-bit	
4:4:4 X'Y'Z'		12-bit		
4:4:4 YCbCr		12-bit/10-bit		
4:2:2 YCbCr		12-bit		
6G-SDI	3840x2160P 29.97/30.00 Hz	4:2:2 YCbCr	10-bit	SMPTE 2081-10
	3840x2160P 25.00 Hz			
	3840x2160P 23.98/24.00 Hz			
	4096x2160P 25.00 Hz			
	4096x2160P 23.98/24.00 Hz			
Dual Link 6G-SDI Square Division, 2 Sample Interleave	3840x2160P 59.94/60.00 Hz	4:2:2 YCbCr	10-bit	SMPTE 2081-11
	3840x2160P 50.00 Hz			

RAW

Signal format
3840x2160P 59.94 Hz, 50.00 Hz, 29.97 Hz, 25.00 Hz, 24.00 Hz, 23.98 Hz
4096x2160P 59.94 Hz, 50.00 Hz, 29.97 Hz, 25.00 Hz, 24.00 Hz, 23.98 Hz

HDMI

Signal format	Color format/Color depth
640x480P 59.94/60.00 Hz	4:4:4 RGB 8-bit
800x600P 60.00 Hz	
1024x768P 60.00 Hz	
720x480P 59.94/60.00 Hz	4:4:4 RGB 12-bit/10-bit/8-bit 4:4:4 YCbCr 12-bit/10-bit/8-bit 4:2:2 YCbCr 12-bit
720x576P 50.00 Hz	
1280x720P 59.94/60.00 Hz	
1280x720P 50.00 Hz	
1920x1080P 59.94/60.00 Hz	
1920x1080i 59.94/60.00 Hz	
1920x1080P 50.00 Hz	
1920x1080i 50.00 Hz	
1920x1080P 29.97/30.00 Hz	
1920x1080P 25.00 Hz	
1920x1080P 23.98/24.00 Hz	
2048x1080P 59.94/60.00 Hz	
2048x1080P 50.00 Hz	
2048x1080P 29.97/30.00 Hz	
2048x1080P 25.00 Hz	
2048x1080P 23.98/24.00 Hz	
3840x2160P 59.94/60.00 Hz	4:4:4 RGB 8-bit 4:4:4 YCbCr 8-bit 4:2:2 YCbCr 12-bit 4:2:0 YCbCr 12-bit/10-bit/8-bit
3840x2160P 50.00 Hz	
3840x2160P 29.97/30.00 Hz	4:4:4 RGB 12-bit/10-bit/8-bit 4:4:4 YCbCr 12-bit/10-bit/8-bit 4:2:2 YCbCr 12-bit
3840x2160P 25.00 Hz	
3840x2160P 23.98/24.00 Hz	
4096x2160P 59.94/60.00 Hz	4:4:4 RGB 8-bit 4:4:4 YCbCr 8-bit 4:2:2 YCbCr 12-bit 4:2:0 YCbCr 12-bit/10-bit/8-bit
4096x2160P 50.00 Hz	
4096x2160P 29.97/30.00 Hz	4:4:4 RGB 12-bit/10-bit/8-bit 4:4:4 YCbCr 12-bit/10-bit/8-bit 4:2:2 YCbCr 12-bit
4096x2160P 25.00 Hz	
4096x2160P 23.98/24.00 Hz	

Image/Frame Display

SDI

96

	Signal system		Display Method	
1280x720	23.98/24.00	P	47.96/48.00	P*
	25.00	P	50.00	P*
	29.97/30.00	P	59.94/60.00	P*
	50.00	P	50.00	P
	59.94/60.00	P	59.94/60.00	P
1920x1080	50.00	i	50.00	P
	59.94/60.00	i	59.94/60.00	P
	23.98/24.00	PsF	47.96/48.00	P*
	25.00	PsF	50.00	P*
	29.97/30.00	PsF	59.94/60.00	P*
	23.98/24.00	P	47.96/48.00	P*
	25.00	P	50.00	P*
	29.97/30.00	P	59.94/60.00	P*
	50.00	P	50.00	P
	59.94/60.00	P	59.94/60.00	P
2048x1080	50.00	i	50.00	P
	59.94/60.00	i	59.94/60.00	P
	23.98/24.00	PsF	47.96/48.00	P*
	25.00	PsF	50.00	P*
	29.97/30.00	PsF	59.94/60.00	P*
	23.98/24.00	P	47.96/48.00	P*
	25.00	P	50.00	P*
	29.97/30.00	P	59.94/60.00	P*
	47.95/48.00	P	47.95/48.00	P
	50.00	P	50.00	P
59.94/60.00	P	59.94/60.00	P	
3840x2160	50.00	i	50.00	P
	59.94/60.00	i	59.94/60.00	P
	23.98/24.00	PsF	47.96/48.00	P*
	25.00	PsF	50.00	P*
	29.97/30.00	PsF	59.94/60.00	P*
	23.98/24.00	P	47.96/48.00	P*
	25.00	P	50.00	P*
	29.97/30.00	P	59.94/60.00	P*
	50.00	P	50.00	P
	59.94/60.00	P	59.94/60.00	P

Signal system			Display Method	
4096x2160	50.00	i	50.00	P
	59.94/60.00	i	59.94/60.00	P
	23.98/24.00	PsF	47.96/48.00	P*
	25.00	PsF	50.00	P*
	29.97/30.00	PsF	59.94/60.00	P*
	23.98/24.00	P	47.96/48.00	P*
	25.00	P	50.00	P*
	29.97/30.00	P	59.94/60.00	P*
	47.95/48.00	P	47.95/48.00	P
	50.00	P	50.00	P
	59.94/60.00	P	59.94/60.00	P

* : Displaying same frame

HDMI

Signal system			Display Method	
640x480	59.94/60.00	P	59.94/60.00	P
800x600	60.00	P	60.00	P
720x480	59.94/60.00	P	59.94/60.00	P
720x576	50.00	P	50.00	P
1024x768	60.00	P	60.00	P
1280x720	59.94/60.00	P	59.94/60.00	P
1280x720	50.00	P	50.00	P
1920x1080	59.94/60.00	P	59.94/60.00	P
1920x1080	59.94/60.00	i	59.94/60.00	P
1920x1080	50.00	P	50.00	P
1920x1080	50.00	i	50.00	P
1920x1080	29.97/30.00	P	59.94/60.00	P*
1920x1080	25.00	P	50.00	P*
1920x1080	23.98/24.00	P	47.96/48.00	P*
2048x1080	59.94/60.00	P	59.94/60.00	P
2048x1080	50.00	P	50.00	P
2048x1080	29.97/30.00	P	59.94/60.00	P*
2048x1080	25.00	P	50.00	P*
2048x1080	23.98/24.00	P	47.96/48.00	P*
3840x2160	59.94/60.00	P	59.94/60.00	P
3840x2160	50.00	P	50.00	P
3840x2160	29.97/30.00	P	59.94/60.00	P*
3840x2160	25.00	P	50.00	P*
3840x2160	23.98/24.00	P	47.96/48.00	P*
4096x2160	59.94/60.00	P	59.94/60.00	P
4096x2160	50.00	P	50.00	P
4096x2160	29.97/30.00	P	59.94/60.00	P*
4096x2160	25.00	P	50.00	P*
4096x2160	23.98/24.00	P	47.96/48.00	P*

* : Displaying same frame

Error Messages

Message		Description and Action
Calibration	Failed to initialize the external sensor.	See CA-310 and CA-210 instruction manual.
	Calibration error.	<ul style="list-style-type: none"> • Check the installation and connection of the external sensor and retry (📖28). • Perform matrix calibration of CA-310 and CA-210 (📖28).
	Calibration is completed. (Brightness setting is lower than target brightness.)	Set the [Luminance] in calibration again (📖46).
	Failed to detect the external sensor. Please check the connection with the sensor.	Correctly connect the external sensor to the USB port of this main unit.
Network	Communication error.	IP address may be in conflict or there may be a network communication error. Check the network environment.
	Invalid IP Address.	Enter the correct IP address.
	Invalid Subnet Mask.	Enter the correct subnet mask.
Various settings, CDL export	The USB memory is full.	Use another USB memory or delete the content of the memory.
	Failed to write file.	The USB memory may be defective or protected. Check the USB memory.
LUT, Various settings, CDL import	(LUT Import) "LUT Type" is different. (CDL Import) "File Type" is different.	Select the correct file format.
	Failed to read file.	The USB memory may be defective or protected. Check the USB memory.
	Failed to import.	There is an error in the file to be imported. Check the file.
	No import file.	Check and ensure that the file has been saved to the USB memory or imported to [User 1] to [User 3].





Error Messages



	Message	Description and Action
Screen Capture	Failed to capture.	The USB memory may be defective or protected. Check the USB memory.
	Invalid Signal.	A screen displaying no video is being captured for example there is no signal or an unsupported signal is being input. Check the signal, input it again, and capture it.
	Copy protected signal.	The signal you tried to capture may be protected by HDCP 2.2 which is a copy prevention standard for HDMI. In this case, the signal cannot be captured. Check the HDMI signal.
	Failed to playback file.	The USB memory or the file may be defective or protected. Check the USB memory or the file.
	No capture file.	Check and ensure that the file has been saved to the USB memory.
Hardware error	Backlight error.	Disconnect the power cord, reconnect it, and then turn on the power. If the message persists, contact Canon Customer Center.
	Fan error.	
	Panel error.	
	I/F error.	
	System error.	
	Invalid operation due to high temperature.	The temperature inside the main unit is high. Turn off the power and wait until the fan stops.
Input signal	No Signal	Displayed when there is no video signal input.
	Unsupported	Unsupported video signal is input. Check the supported signal format (82).
	"Input Configuration" is different from Payload.	Check the [Input Configuration] (53) and [Signal Information] (78) settings. Reset any incorrect [Input Configuration] settings.
Operation	Invalid operation.	Operation is disabled. Check the setting items.
	"Protect Settings" is on.	To use the OSD menu, move the selection frame to [Protect] and press the jog dial for approximately 3 seconds.
	"CDL/User LUT Bypass" is on.	When [CDL/User LUT Bypass] is turned [On], you cannot adjust [Power], [Saturation], [Offset], or [Slope].
	Invalid Password.	Enter the correct password.
USB memory	USB memory is not connected.	Correctly connect the USB memory to the USB port of this main unit.
	Unsupported USB memory.	Check the USB memory format and make sure it is not protected.

	Message	Description and Action
DC power supply	Low Voltage.	The battery charge level drops if using the battery. If you use another power source, check the input voltage of the DC power supply.
	Low Voltage, Turn off power.	The power has shut off as DC power voltage became insufficient for continued operation. There may not be enough energy left if you are using the battery. Connect a charged battery and turn the video display power on. If you use another power source, check the input voltage of the DC power supply.
	Invalid Voltage, Turn off power.	The power has shut off as the DC power input voltage exceeded the operational threshold. Check the input voltage of the DC power supply.

Troubleshooting

102

Symptom	Cause and Action	
Power does not turn on. (Power indicator does not turn on.)	<ul style="list-style-type: none"> • Press the  button. 	11
	<ul style="list-style-type: none"> • Check that the AC power supply or DC power cord is connected correctly. 	22
	<ul style="list-style-type: none"> • Brightness of the power indicator may be turned off. Turn it on and check once more. 	73
The screen is dark.	When the power indicator does not turn on: <ul style="list-style-type: none"> • Press the  button. • Check that the AC power supply or DC power cord is connected correctly. 	11 22
	When the power indicator is lit orange: <ul style="list-style-type: none"> • Press the  button. 	22
	When the power indicator is flashing orange: <ul style="list-style-type: none"> • Flashing once every 3 seconds : Contact Canon Customer Center. • Flashing twice every 3 seconds : <ul style="list-style-type: none"> - Turn on the power with the  button. - The temperature of the display rises (or falls) depend on operation environment. Check the environmental conditions and do not use in direct sunlight. - If the power still does not turn on, contact Canon Customer Center. 	22 79
The power suddenly goes off when a DC power supply is used.	<ul style="list-style-type: none"> • Depending on the model of DC power supply used, the output voltage may decrease suddenly and even turn off (0 V output) when a threshold value is reached. Before that, a warning message about low input voltage may be displayed only briefly or not at all. Connect a charged DC power supply or AC power supply. 	—
The image does not display.	<ul style="list-style-type: none"> • Set each item in [Channel Settings] according to input signal. 	53
The 3G-SDI RAW signal image does not display.	<ul style="list-style-type: none"> • At times the 3G-SDI RAW signal image may not display, depending on the type of the CINEMA EOS SYSTEM camera. Refer to the Canon website for a list of supported products. 	—
There is a blank area when set to Quad Input/Dual Input.	<ul style="list-style-type: none"> • There may be no input signal. Check the signal. 	20
	<ul style="list-style-type: none"> • Signals with different resolution or frequency may be input from each terminal. Check the signal. 	78
Screen is too bright/dark.	<ul style="list-style-type: none"> • Adjust the [Contrast] on the OSD menu. • There is a limit on the service life of LCD backlight. If the screen becomes dark or starts flickering, contact Canon Customer Center. 	40
Burn-in image appears.	<ul style="list-style-type: none"> • This is a characteristic of the LCD panel and you should avoid displaying stationary image for a long time. 	—

Symptom	Cause and Action	
There is an unlit or red, blue, green, or white dot on screen.	<ul style="list-style-type: none"> LCD display is made of very high precision technology. It has effective pixels of 99.99% or more, but there may be black dots or red, blue, or green dots that may be always on. This is not a failure. 	—
There is an interference pattern or trace that remains when the LCD panel is pressed.	<ul style="list-style-type: none"> The symptom may be resolved by displaying a white or black image on the entire screen. 	—
OSD menu cannot be used.	<ul style="list-style-type: none"> Check that [Protect Settings] is not set. 	74
[Aspect Marker], [Safety Zone Marker] or [Area Marker] does not appear.	<ul style="list-style-type: none"> A channel with no signal, unsupported signal, or with [Input Configuration] not set may be selected. Check the signal. 	78
The fan starts to rotate even when [Fan] under [Camera Link] is set to [On] or [Fan Stop] is set to [On].	<ul style="list-style-type: none"> The fan stays off for approx. 1 minute when an AC power supply is used. To keep the fan off for a longer period, use a DC power supply. The fan operates to lower the temperature inside the main unit. The fan stops operating when the temperature inside has lowered. When [Fan] under [Camera Link] is set to [On], the down time may not match the camera. 	69 73
The fan does not stop even when [Fan] under [Camera Link] is set to [On] or [Fan Stop] is set to [On].	<ul style="list-style-type: none"> The fan does not stop if the temperature inside the main unit is high. Configure settings after the internal temperature has lowered. The fan may not stop in some conditions, for example when used at a high temperature. Use the video display at the operating temperature ( 79) or lower. 	69 73
Loud fan noise	<ul style="list-style-type: none"> The fan operates at a faster speed than usual to lower the internal temperature if [Fan Control] is set to [On] and when the temperature inside the main unit has increased. The fan operates at normal speed when [Fan Control] is set to [Off]. When high-luminance content is displayed continuously, the temperature inside the main unit rises even if the operating temperature is within the recommended range, and the fan operates at a faster speed than usual to lower the internal temperature. It is recommended to lower the brightness of the video display. 	73
You forgot the password for [Protect Settings].	<ul style="list-style-type: none"> Press the jog dial and the  button while the video display is in standby. The configuration will be reset to the state where no password is set. 	11
The video display does not start up in the condition that the power was turned off last time.	<ul style="list-style-type: none"> Check the [Power on Setting] on the OSD menu. Set [Last memory] to start up the video display in the condition that the power is turned off last time. 	75
The image quality for the User mode in [Picture Mode] differs from the image quality of presets.	<ul style="list-style-type: none"> Select the preset mode by [Copy Picture Mode] and copy the settings. 	47
In the [Multi View (Dual)] display, the image quality of the screens on the left and right differ.	<ul style="list-style-type: none"> Check the settings of [Picture Mode], [Picture Function Target] under [Channel Settings] or check the other settings for [Multi View (Dual)] display. 	55

Software Used in This Product

104 Software installed with this product includes software modules from Canon or third parties.

Software Developed by Canon and Free Software

Software developed or created by Canon and accompanying document is protected by copyright law, terms of an international convention and any other governing laws.

This product uses software modules under copyright by third parties and distributed as free software. Some of these software modules are subject to the GNU General Public License v2 (GPL), GNU Lesser General Public License v2.1 (LGPL) or any other license.

Free software modules installed with this product

- linux kernel
- SquashFS
- avahi-autoipd
- busybox
- FUSE
- libxml
- glibc
- libfuse
- zlib
- JFFS2
- libupnp
- libpng

Acquiring Source Code for Free Software

Some free software requires the acquirement of the source code of modules in order to distribute the executable form of those software modules. For information on how to acquire the source code for free software such as these and confirming terms of the GPL, LGPL and other license agreements, please check with the distributor from whom the product was purchased.

License Agreement for this Product

Obligation to Present License Agreement

The copyright holders of software modules installed with this product require its license agreement to be displayed. This license agreement is as follows:

■libupnp License

Copyright (c) 2000-2003 Intel Corporation All rights reserved.

Redistribution and use in source and binary forms, with or without modification, are permitted provided that the following conditions are met:

- * Redistributions of source code must retain the above copyright notice, this list of conditions and the following disclaimer.
- * Redistributions in binary form must reproduce the above copyright notice, this list of conditions and the following disclaimer in the documentation and/or other materials provided with the distribution.
- * Neither name of Intel Corporation nor the names of its contributors may be used to endorse or promote products derived from this software without specific prior written permission.

THIS SOFTWARE IS PROVIDED BY THE COPYRIGHT HOLDERS AND CONTRIBUTORS "AS IS" AND ANY EXPRESS OR IMPLIED WARRANTIES, INCLUDING, BUT NOT LIMITED TO, THE IMPLIED WARRANTIES OF MERCHANTABILITY AND FITNESS FOR A PARTICULAR PURPOSE ARE DISCLAIMED. IN NO EVENT SHALL INTEL OR CONTRIBUTORS BE LIABLE FOR ANY DIRECT, INDIRECT, INCIDENTAL, SPECIAL, EXEMPLARY, OR CONSEQUENTIAL DAMAGES (INCLUDING, BUT NOT LIMITED TO, PROCUREMENT OF SUBSTITUTE GOODS OR SERVICES; LOSS OF USE, DATA, OR PROFITS; OR BUSINESS INTERRUPTION) HOWEVER CAUSED AND ON ANY THEORY OF LIABILITY, WHETHER IN CONTRACT, STRICT LIABILITY, OR TORT (INCLUDING NEGLIGENCE OR OTHERWISE) ARISING IN ANY WAY OUT OF THE USE OF THIS SOFTWARE, EVEN IF ADVISED OF THE POSSIBILITY OF SUCH DAMAGE.

■ **libxml License**

Copyright (C) 1998-2003 Daniel Veillard. All Rights Reserved.

Permission is hereby granted, free of charge, to any person obtaining a copy of this software and associated documentation files (the "Software"), to deal in the Software without restriction, including without limitation the rights to use, copy, modify, merge, publish, distribute, sublicense, and/or sell copies of the Software, and to permit persons to whom the Software is furnished to do so, subject to the following conditions:

The above copyright notice and this permission notice shall be included in all copies or substantial portions of the Software.

THE SOFTWARE IS PROVIDED "AS IS", WITHOUT WARRANTY OF ANY KIND, EXPRESS OR IMPLIED, INCLUDING BUT NOT LIMITED TO THE WARRANTIES OF MERCHANTABILITY, FITNESS FOR A PARTICULAR PURPOSE AND NONINFRINGEMENT. IN NO EVENT SHALL THE DANIEL VEILLARD BE LIABLE FOR ANY CLAIM, DAMAGES OR OTHER LIABILITY, WHETHER IN AN ACTION OF CONTRACT, TORT OR OTHERWISE, ARISING FROM, OUT OF OR IN CONNECTION WITH THE SOFTWARE OR THE USE OR OTHER DEALINGS IN THE SOFTWARE.

Except as contained in this notice, the name of Daniel Veillard shall not be used in advertising or otherwise to promote the sale, use or other dealings in this Software without prior written authorization from him.

Index

Number

2 Sample Interleave	54
3G-SDI RAW	12, 21
5 Step (Test Pattern)	68
6G/3G/HD-SDI	12, 20
200% (Screen Scaling)	56
2020 Constant Luminance	46
2020 Gamut Mapping	46

A

ACESproxy	40
Adjustment	40
Adobe RGB	40
Anchor Adjustment	27, 47
Area Marker	62
Area Marker (Camera Link)	69
Aspect Marker	60
Audio Input	55
Audio Level Meter	67
Audio Settings	59
Automatic Adjustment (ARRI)	69
Automatic Adjustment (CINEMA EOS)	69

B

Backlight Control	40
Banner	68
Bias R/G/B	40
Bicubic	57
Black (Test Pattern)	68
Blue Off	68
Blue Only	68
Blue (Test Pattern)	68
Brightness	40

C

Calibration	28, 46
Camera Information	69
Camera Link	69
Canon Log, CanonLog 2, Canon Log 3	40, 41
CDL Export/CDL Import	31
CDL/User LUT Bypass	44
Center Marker	63
Channel Name	32, 55

Channel Settings	53
Chroma	40
Cinema Gamut to 709	41
Cinema Gamut to 2020	41
Cinema Gamut to DCI	41
Color Bars (Test Pattern)	68
Color Gamut	41
Color Range	43
Color Temperature	40
Compatible Settings	73
Configure an IP Address	72
Contrast	40
Custom (xy) (Color Temperature)	40

D

Date/Time	32, 72
DCI-P3	40
DCI-P3+ to 709	41
DCI-P3+ to DCI	41
Detail Settings	
Adjustment	45
CDL	44
Display Button LED	73
Display Channel	72
Display Function/Display Function (CDL)	72
Display Name	32, 73
Display Settings	56
Dual Input	53
Dual Link 3G-SDI	54

E

EBU	40
Export/Import	31, 74

F

False Color	65
Fan Control	73
Film Cadence	58
Firmware Ver.	78
Format	54
Frame Hold	57
Function/Channel Button	72
Function Guide	68

Function Settings.....	65	Marker Preset.....	60
G		Marker Settings	60
Gain R/G/B.....	40	Marker/TC/WFM/VEC Input.....	55
Gamma	41	Monochrome.....	68
Gamma LUT.....	41	Multi View (Dual)	54
Gamut LUT.....	41	Multi View (Quad).....	54
Gray (20%) (Test Pattern)	68	N	
Green Off.....	68	Native Input Resolution (Screen Scaling)	56
Green (Test Pattern).....	68	Nearest Neighbor	57
Grid Marker	63	Network	72
H		Network/Remote(GPI) Settings	72
HDMI.....	12, 21	O	
HDR Range	42	Offset	44
HDR/SDR View	46	OSD Menu	24, 36
HD-SDI.....	12, 20	Output Transform	43
Hide OSD	77	Output Transform Surround	43
Hybrid Log-Gamma System	46	P	
Hybrid Log-Gamma Y/RGB.....	42	Password	74
I		Peaking	65
Image Division	54	Picture Function Target.....	55
Image Priority	58	Picture Mode.....	40
In Monitor Display.....	72	Picture Mode R	55
Input Configuration	53	PLUGE (Test Pattern).....	68
Input Transform	43	Power.....	44
Internal Sync	54	Power Indicator Brightness.....	73
I/P Conversion.....	58	Power on Setting.....	75
I/PsF.....	57	Protect Settings.....	74
ITU-R BT.709.....	40	PsF.....	58
ITU-R BT.1886.....	41	Q	
ITU-R BT.2020.....	40	Quad Input	53
L		R	
LAN.....	12	Ramp (Test Pattern).....	68
Language	72	Red Off.....	68
Local Dimming	40	Red (Test Pattern)	68
LTC	65	Remote(GPI).....	73
Luminance.....	46	Reset.....	47
LUT Import	30, 45	Reset All Settings	75
M		S	
MAC Address	78	Safety Zone Marker 1, 2	61

Saturation.....	44
Scaling Method	57
Screen Capture	68
Screen Scaling	56
Select Channel	53
Select Input Signal.....	53
Separator	55
Serial No.....	78
Settings.....	31, 74
Shape Trace	57
Sharpness	40
Signal Information.....	78
Single Input	53
Slope.....	44
SMPTE-C	40
Speed Priority.....	58
Square Division.....	54
Subnet Mask	72
System Information.....	78
System Settings	72

T

Tally light.....	11
Test Pattern	68
Time Code	65

U

Usage Time.....	78
USB	11, 28, 30
User 1 to 7	40
User LUT.....	44

V

Various Function (Function Settings)	68
Vector Scope.....	67
VITC	65

W

Wave Form Monitor	66
White (Test Pattern)	68

Y

YCbCr Color Matrix	45
--------------------------	----

Z

Zoom	57
------------	----

**CANON PROFESSIONAL DISPLAY LIMITED WARRANTY FOR PRODUCTS PURCHASED
IN THE UNITED STATES**

The limited warranty set forth below is given by Canon U.S.A., Inc. ('Canon USA') with respect to Canon Professional Display Equipment (the 'Equipment') accompanying this limited warranty in the Equipment's original container, when purchased in the United States. This limited warranty is only effective upon presentation of your Bill of Sale or other proof of purchase.

Canon USA warrants to the original end-user purchaser, when delivered in new condition in its original container, that the Equipment will be free from defects in materials and workmanship under normal use and service for a period of ONE-YEAR from the date of original purchase. When returning Equipment under this warranty, you must pre-pay the shipping charges, and you must enclose a copy of the Bill of Sale or other proof of purchase with a complete explanation of the problem. Equipment returned to a Canon USA factory service facility, and proven to be defective upon inspection, will be, without charge,:

- (a) repaired utilizing new or comparable refurbished parts, or
- (b) exchanged for refurbished or new Equipment

as determined in the Canon USA's repair facility's sole discretion. The repaired or exchanged Equipment will be shipped back free of charge. Warranty exchange or replacement does not extend the original warranty period of the Equipment. For repairs after the warranty period has expired, an estimate of the cost of repair and an opportunity to approve or reject the repair expense before it is incurred will be provided. If you approve, repairs will be made and the Equipment will be returned at your risk and expense. If you reject, the Equipment will be returned to you at no charge to you to an address within the United States.

This limited warranty only applies if the Equipment is used in conjunction with compatible computer equipment, compatible peripheral equipment and compatible software, as to which items Canon USA will have no responsibility. Canon USA shall have no responsibility under this limited warranty for use of the Equipment in conjunction with incompatible peripheral equipment and/or incompatible software. Non-Canon brand peripheral equipment and software which may be distributed with, or be factory loaded on, the Equipment, are sold 'AS IS' without warranty of any kind by Canon USA, including any implied warranty regarding merchantability or fitness for a particular purpose. The sole warranty with respect to such non-Canon brand items is given by the manufacturer or producer thereof. If the Equipment contains a hard disk drive, Canon USA recommends that data stored on that drive be duplicated or backed up to prevent its loss in the event of failure or other malfunction of such drive.

In order to obtain warranty service, please contact the authorized Canon retail dealer from whom you purchased the Equipment or contact the CANON INFORMATION CENTER AT **855-4K-CANON** (855-452-2666) or on the internet at pro.usa.canon.com/support. You will be directed to the nearest service facility for your Equipment.

Technical support program specifics subject to change without notice.

This Limited Warranty covers all defects encountered in normal use of the Equipment and does not apply in the following cases:

- A. Loss or damage to the Equipment due to abuse, neglect, mishandling, electric current fluctuation, accident, improper maintenance, use of non-Canon accessories or failure to follow operating, maintenance or environmental instructions prescribed in Canon USA's user's manual;
- B. If the Equipment is defective as a result of sand, dirt or water damage;
- C. If defects or damages are caused by the use of parts or supplies (other than those sold by Canon USA) that cause damage to the Equipment or that cause abnormally frequent service calls or service problems;
- D. If defects or damages are caused by service other than Canon USA's factory service centers or authorized service facilities;
- E. Any internal modification to product hardware or firmware;
- F. Any maintenance of the Equipment, including any fees for such Maintenance;
- G. If the Equipment has had its serial number or dating altered or removed.

This Limited Warranty does not apply to Equipment purchased outside the United States. This Limited Warranty does not apply to accessories or consumables for the Equipment, which are sold "AS IS", without warranty of any kind by Canon USA. Please retain this warranty card and your Bill of Sale as a permanent record of your purchase. This card ensures that you are contacted promptly should there be a safety inspection, modification or product recall under applicable laws or regulations. This card ensures that you are contacted promptly should there be a safety inspection, modification or product recall under applicable laws or regulations.

NO IMPLIED WARRANTY, INCLUDING MERCHANTABILITY AND FITNESS FOR A PARTICULAR PURPOSE APPLIES TO THIS EQUIPMENT AFTER THE APPLICABLE PERIOD OF EXPRESS WARRANTY OR GUARANTY UNDER THIS WARRANTY (EXCEPT AS MENTIONED ABOVE). (SOME STATES DO NOT ALLOW LIMITATIONS ON HOW LONG AN IMPLIED WARRANTY LASTS, SO THE ABOVE LIMITATION OR EXCLUSION MAY NOT APPLY TO YOU). CANON USA SHALL NOT BE LIABLE FOR LOSS OF REVENUES OR PROFITS, EXPENSE FOR SUBSTITUTE EQUIPMENT OR SERVICE, STORAGE CHARGES, LOSS OR CORRUPTION OF DATA, INCLUDING WITHOUT LIMITATION, LOSS OR CORRUPTION OF DATA STORED ON THE EQUIPMENT'S HARD DRIVE, OR ANY OTHER SPECIAL, INCIDENTAL OR CONSEQUENTIAL DAMAGES CAUSED BY THE USE, MISUSE OR INABILITY TO USE THE EQUIPMENT, REGARDLESS OF THE LEGAL THEORY ON WHICH THE CLAIM IS BASED, AND EVEN IF CANON USA HAS BEEN ADVISED OF THE POSSIBILITY OF SUCH DAMAGES. NOR SHALL RECOVERY OF ANY KIND AGAINST CANON USA BE GREATER THAN THE PURCHASE PRICE OF THE EQUIPMENT SOLD BY CANON USA AND CAUSING THE ALLEGED DAMAGE. WITHOUT LIMITING THE FOREGOING, YOU ASSUME ALL RISK AND LIABILITY FOR LOSS, DAMAGE OR INJURY TO YOU AND YOUR PROPERTY AND TO OTHERS AND THEIR PROPERTY ARISING OUT OF USE, MISUSE OR INABILITY TO USE THE EQUIPMENT NOT CAUSED DIRECTLY BY THE NEGLIGENCE OF CANON USA (SOME STATES DO NOT ALLOW THE EXCLUSION OR LIMITATION OF INCIDENTAL OR CONSEQUENTIAL DAMAGES, SO THE ABOVE LIMITATION MAY NOT APPLY TO YOU). THIS WARRANTY SHALL NOT EXTEND TO ANYONE OTHER THAN THE ORIGINAL PURCHASER OF THIS EQUIPMENT OR THE PERSON FOR WHOM IT WAS PURCHASED AS A GIFT.

This warranty gives you specific legal rights, and you may also have other rights which vary from state to state.

CANON U.S.A., INC

CANON PROFESSIONAL DISPLAY LIMITED WARRANTY FOR PRODUCTS PURCHASED IN CANADA

The limited warranty set forth below is given by Canon Canada Inc. ('Canon Canada') with respect to Canon Professional Display Equipment (the 'Equipment') accompanying this limited warranty in the Equipment's original container, when purchased in Canada. This limited warranty is only effective upon presentation of your bill of sale or other proof of purchase.

Canon Canada warrants to the original end-user purchaser, when delivered in new condition in its original container, that the Equipment will be free from defects in materials and workmanship under normal use and service for a period of ONE YEAR from the date of original purchase. When returning Equipment under this limited warranty, you must pre-pay the shipping charges, and you must enclose a copy of the bill of sale or other proof of purchase with a complete explanation of the problem. Equipment returned to a Canon Canada factory service facility and proven to be defective upon inspection will be, without charge:

- (a) repaired utilizing new or comparable refurbished parts, or
- (b) exchanged for refurbished or new Equipment,

as determined by the Canon Canada factory service center, in its sole discretion. The repaired or exchanged Equipment will be shipped back free of charge. Warranty exchange or replacement does not extend the original warranty period of the Equipment. For repairs after the warranty period has expired, an estimate of the cost of repair and an opportunity to approve or reject the repair expense before it is incurred will be provided. If you approve the proposed repairs, repairs will be made and the Equipment will be returned at your risk and expense. If you reject the proposed repairs, the Equipment will be returned to you at no charge to you to an address within Canada.

This limited warranty only applies if the Equipment is used in conjunction with compatible computer equipment, compatible peripheral equipment and compatible software, as to which items Canon Canada will have no responsibility. Canon Canada shall have no responsibility under this limited warranty for use of the Equipment in conjunction with incompatible computer equipment, peripheral equipment and/or incompatible software. Non-Canon brand peripheral equipment and software which may be distributed with, or be factory loaded on, the Equipment, are sold 'AS IS' without warranty or condition of any kind by Canon Canada, including any implied warranty or condition regarding merchantability or fitness for a particular purpose. The sole warranty with respect to such non-Canon brand items is given by the manufacturer or producer thereof. If the Equipment contains a hard disk drive, Canon Canada recommends that data stored on that drive be duplicated or backed up to prevent its loss in the event of failure or other malfunction of such drive.

In order to obtain warranty service, please contact the authorized Canon retail dealer from whom you purchased the Equipment or contact the CANON INFORMATION CENTER at **800-667-2666** or on the internet at www.canon.ca/pro.

Technical support program specifics are subject to change without notice.

This limited warranty covers all defects encountered in normal use of the Equipment and does not apply in the following cases:

- A. Loss or damage to the Equipment due to abuse, neglect, mishandling, electric current fluctuation, accident, improper maintenance, use of non-Canon accessories or failure to follow operating, maintenance or environmental instructions prescribed in Canon Canada's users manual;
- B. If the Equipment is defective as a result of sand, dirt or water damage;
- C. If defects or damages are caused by the use of parts or supplies (other than those sold by Canon Canada) that cause damage to the Equipment or that cause abnormally frequent service calls or service problems
- D. If defects or damages are caused by service other than Canon Canada's factory service centers or authorized service facilities;
- E. Any internal modification to product hardware or firmware;
- F. Any maintenance of the Equipment, including any fees for such maintenance; or
- G. If the Equipment has had its serial number or dating altered or removed.

This limited warranty does not apply to Equipment purchased outside Canada. This limited warranty does not apply to accessories or consumables for the Equipment, which are sold "AS IS", without warranty or condition of any kind by Canon Canada. Please retain this warranty card and your bill of sale or other proof of purchase as a permanent record of your purchase. This card ensures that you are contacted promptly should there be a safety inspection, modification or product recall under applicable laws or regulations.

112

NO IMPLIED WARRANTY OR CONDITION, INCLUDING IN RESPECT OF THE MERCHANTABILITY AND FITNESS FOR A PARTICULAR PURPOSE, APPLIES TO THIS EQUIPMENT AFTER THE EXPIRATION OF THE APPLICABLE PERIOD OF EXPRESS WARRANTY OR GUARANTEE UNDER THIS LIMITED WARRANTY (EXCEPT AS MENTIONED ABOVE). (SOME PROVINCES DO NOT ALLOW LIMITATIONS ON HOW LONG AN IMPLIED WARRANTY LASTS, SO THE ABOVE LIMITATION OR EXCLUSION MAY NOT APPLY TO YOU). CANON CANADA SHALL NOT BE LIABLE FOR LOSS OF REVENUES OR PROFITS, EXPENSE FOR SUBSTITUTE EQUIPMENT OR SERVICE, STORAGE CHARGES, LOSS OR CORRUPTION OF DATA, INCLUDING WITHOUT LIMITATION, LOSS OR CORRUPTION OF DATA STORED ON THE EQUIPMENT'S HARD DRIVE, OR ANY OTHER SPECIAL, INCIDENTAL OR CONSEQUENTIAL DAMAGES CAUSED BY THE USE, MISUSE OR INABILITY TO USE THE EQUIPMENT, REGARDLESS OF THE LEGAL THEORY ON WHICH THE CLAIM IS BASED, AND EVEN IF CANON CANADA HAS BEEN ADVISED OF THE POSSIBILITY OF SUCH DAMAGES. NOR SHALL RECOVERY OF ANY KIND AGAINST CANON CANADA BE GREATER THAN THE PURCHASE PRICE OF THE EQUIPMENT SOLD BY CANON CANADA AND CAUSING THE ALLEGED DAMAGE. WITHOUT LIMITING THE FOREGOING, YOU ASSUME ALL RISK AND LIABILITY FOR LOSS, DAMAGE OR INJURY TO YOU AND YOUR PROPERTY AND TO OTHERS AND THEIR PROPERTY ARISING OUT OF USE, MISUSE OR INABILITY TO USE THE EQUIPMENT NOT CAUSED DIRECTLY BY THE NEGLIGENCE OF CANON CANADA (SOME PROVINCES DO NOT ALLOW THE EXCLUSION OR LIMITATION OF INCIDENTAL OR CONSEQUENTIAL DAMAGES, SO THE ABOVE LIMITATION MAY NOT APPLY TO YOU). THIS LIMITED WARRANTY SHALL NOT EXTEND TO ANYONE OTHER THAN THE ORIGINAL PURCHASER OF THIS EQUIPMENT OR THE PERSON FOR WHOM IT WAS PURCHASED AS A GIFT.

This limited warranty gives you specific legal rights, and you may also have other rights which vary from province to province.

CANON CANADA INC.



Canon Inc. 30-2, Shimomaruko 3-chome, Ohta-ku, Tokyo 146-8501, Japan

AUSTRALIA www.canon.com.au

Canon Australia Pty Ltd

☎ 13-13-83 (within Australia only)

☎ (61) 02-9805-2000

CANADA

CANON CANADA INC.

<http://www.canon.ca>

❖ Professional Product Support / Soutien des produits professionnels

☎ (800) 667-2666

CENTRO Y SURAMÉRICA

CANON U.S.A. - Latin America Group

<http://www.cla.canon.com>

EUROPE www.canon-europa.com

Canon Europa N.V.

Bovenkerkerweg 59,

1185 XB Amstelveen, The Netherlands

MÉXICO

CANON MEXICANA, S DE RL DE CV

<http://www.canon.com.mx>

☎ 52 (55) 5249-4905

NEW ZEALAND www.canon.co.nz

Canon New Zealand Ltd

☎ 0800-222-666 (within New Zealand only)

☎ (64) 09-489-0300

UNITED KINGDOM www.canon.co.uk

Canon UK Ltd

CCI Service Centre, Unit 130, Centennial Park,
Borehamwood, Hertfordshire, WD6 3SE

☎ 0844-369-0100

USA

CANON U.S.A., INC.

<http://pro.usa.canon.com>

<http://pro.usa.canon.com/support>

☎ (855) 4K-CANON (855-452-2666)
(USA only)

캐논코리아컨슈머이미징㈜

<http://www.canon-ci.co.kr>

서울특별시 강남구 테헤란로607, 캐논빌딩 5층

대표전화+82(0)2-1588-8133

Canon Korea Consumer Imaging Inc.

<http://www.canon-ci.co.kr>

5F, Canon Bldg, 607, Teheran-ro, Gangnam-gu,
Seoul, Korea

☎ +82(0)2-1588-8133

Visit your local Canon Web site to download the latest version of this instruction manual.