



Canon

PowerShot D20

Getting Started

Please refer to the complete user guide included on the CD-ROM for more detailed information.

- Before use, be sure to read this guide, including the safety precautions.
- This guide will familiarize you with how to use the camera correctly.
- Keep the guide handy for future reference.

ENGLISH

Package Contents

Before use, make sure the following items are included in the package. If anything is missing, contact your camera dealer.



Camera

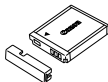

Battery Pack NB-6L
(with terminal cover)

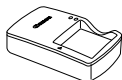

Battery Charger
CB-2LY/CB-2LYE

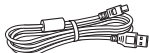

Interface Cable
IFC-400PCU



Wrist Strap
WS-DC8



Strap Mount



Getting Started



DIGITAL CAMERA
Solution Disk



Warranty
Card

- A memory card is not included (p. 2).

About Getting Started (This Guide) and the PDF Manuals

This guide introduces basic camera operations.

To master more advanced operations and use the included software, refer to the PDF manuals on the CD-ROM (p. 23).



- Adobe Reader is required to view the PDF manuals.

Compatible Memory Cards

The following memory cards (sold separately) can be used, regardless of capacity.

- SD memory cards*
- SDHC memory cards*
- SDXC memory cards* 
- Eye-Fi cards

* Conforms to SD specifications. However, not all memory cards have been verified to work with the camera.

About Eye-Fi Cards

This product is not guaranteed to support Eye-Fi card functions (including wireless transfer). In case of an issue with an Eye-Fi card, please check with the card manufacturer.

Also note that an approval is required to use Eye-Fi cards in many countries or regions. Without approval, use of the card is not permitted. If it is unclear whether the card has been approved for use in the area, please check with the card manufacturer.



- Always confirm beforehand that memory cards are supported on other devices such as card readers and computers (including the current version of your operating system).

Preliminary Notes and Legal Information

- Take and review some test shots initially to make sure the images were recorded correctly. Please note that Canon Inc., its subsidiaries and affiliates, and its distributors are not liable for any consequential damages arising from any malfunction of a camera or accessory, including memory cards, that results in the failure of an image to be recorded or to be recorded in a way that is machine readable.
- Images recorded by the camera are intended for personal use. Refrain from unauthorized recording that infringes on copyright law, and note that even for personal use, photography may contravene copyright or other legal rights at some performances or exhibitions, or in some commercial settings.
- The camera warranty is valid only in the area of purchase. In case of camera problems while abroad, return to the area of purchase before contacting a Canon Customer Support Help Desk.
- Although the LCD monitor is produced under extremely high-precision manufacturing conditions and more than 99.99% of the pixels meet design specifications, in rare cases some pixels may be defective or may appear as red or black dots. This does not indicate camera damage or affect recorded images.
- The LCD monitor may be covered with a thin plastic film for protection against scratches during shipment. If covered, remove the film before using the camera.
- When the camera is used over an extended period, it may become warm. This does not indicate damage.

Part Names and Conventions in This Guide

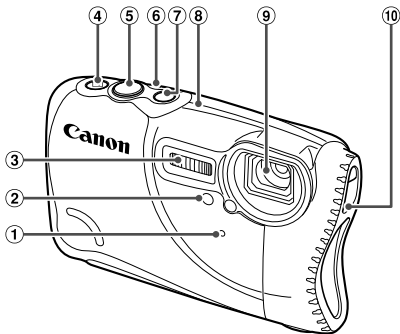

- | | |
|--|--|
| ① Microphone | ⑥ Indicator |
| ② Lamp | ⑦ Power button |
| ③ Flash | ⑧ GPS antenna |
| ④  (Playback) button | ⑨ Lens |
| ⑤ Shutter button | ⑩ Shoulder strap/carabiner strap mount |

- ⓘ : Important information you should know
-  : Notes and tips for expert camera use
- (p. xx): Pages with related information (in this example, “xx” represents a page number)
- Instructions in this guide apply to the camera under default settings.
- For convenience, all supported memory cards are simply referred to as “the memory card”.
- The tabs shown above titles indicate whether the function is used for still images, movies, or both.

Still Images : Indicates that the function is used when shooting or viewing still images.

Movies : Indicates that the function is used when shooting or viewing movies.

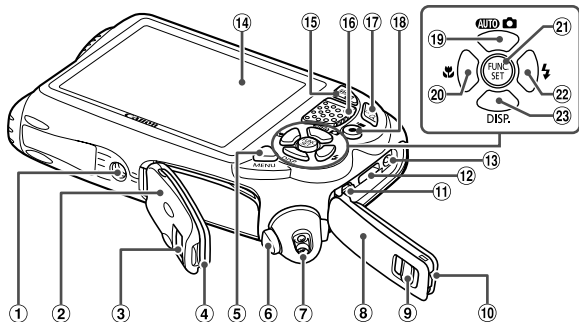

- | | |
|---|---|
| ① Tripod socket | ⑮ Zoom button
Shooting: (wide angle)
Playback: (index) |
| ② Memory card/battery cover | ⑯ Speaker |
| ③ Memory card/battery cover lock | ⑰ Zoom button
Shooting: (telephoto)
Playback: (magnify) |
| ④ Waterproof seal | ⑱ Movie button |
| ⑤ MENU button | ⑲ Mode selection / Up button |
| ⑥ Release button | ⑳ (Macro) / Left button |
| ⑦ Strap mount | ㉑ FUNC./SET button |
| ⑧ Terminal cover | ㉒ (Flash) / Right button |
| ⑨ Terminal cover lock | ㉓ DISP. (Display) / Down button |
| ⑩ Waterproof seal | |
| ⑪ AV OUT (Audio/video output) /
DIGITAL terminal | |
| ⑫ HDMI™ terminal | |
| ⑬ DC IN (Power input) terminal | |
| ⑭ Screen (LCD monitor) | |

- In this guide, icons are used to represent the corresponding camera buttons on which they appear, or which they resemble.
- The following camera buttons are represented by icons.
 - ▲ Up button ⑲ on back
 - ◀ Left button ⑳ on back
 - FUNC./SET** button ㉑ on back
 - ▶ Right button ㉒ on back
 - ▼ Down button ㉓ on back
- On-screen text is indicated in brackets.

Cautions When Using this Waterproof, Dustproof, and Shock Resistant Camera

You can enjoy using this camera in the rain, on the beach, while skiing, or underwater within a depth of 10 m (33 ft.). However, it can not be used in hot springs or other mineralized waters. Please be aware that Canon is not liable for any damage to the camera, batteries, memory cards, or saved data caused by water leakage due to mistaken operation of the product. This camera is subjected to Canon standard testing. However, it is not guaranteed that this camera will not damage or malfunction. (For more information about waterproof, dustproof, and shock resistant specifications, see “Specifications” (p. 29).)

Cautions Before Using This Camera

- Before shooting with the camera, confirm that the memory card/battery cover and terminal cover (p. 5) are fully closed (pp. 14, 18). If either cover is not fully closed, water may enter the camera and damage it.
- Be sure that the waterproof seals (p. 13) inside the covers and the areas around them are kept free from scratches and foreign objects such as sand, dirt, or hair. Not doing so may result in leaks. If the waterproof seal is damaged, do not use the camera underwater.
- Avoid opening and closing the covers while on the beach or near water. Change memory cards and batteries in a dry place protected from sea breezes.
- Do not open the covers if the camera is wet. If there is moisture on the camera, wipe it off with a soft, dry cloth until it is completely dry.

Cautions While Using This Camera

- Do not use this camera in water deeper than 10 m (33 ft.).
- Do not expose the camera to strong impacts or shocks while underwater. Impacts could cause the covers to open or otherwise compromise the waterproof ability of the camera.
- This camera is deemed shock resistant by Canon standard testing (see “Specifications” (p. 29)). However, strong impacts could scratch the camera or cause it to malfunction. Do not allow the camera to fall a great distance or expose it to excessive shocks.
- Waterproof performance is not ensured if the camera is dropped or subjected to impact.

Cautions After Using This Camera and Camera Care

- Rinse off the camera if there is liquid or sand on it after use. The liquid may soil or corrode the camera, and wiping the camera when sand is on it may scratch it.
- After using the camera under water (especially in the ocean) or in sandy or dirty environments, promptly rinse it well under fresh water, such as tap water no warmer than 30 °C (86 °F). Foreign material or salty residue on the camera may corrode metal parts or cause buttons to stick.
- After washing the camera, dry it completely by wiping it with a soft, dry cloth. After washing and drying the camera, make sure the buttons and covers do not stick when pressed or opened and closed.
- To avoid damaging the waterproof seals and causing leaks, keep the seals free of sand or other foreign material, and do not apply chemicals or grease to the seals.

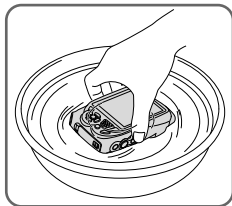

About the Waterproof Seals

- Scratches or cracks in the waterproof seals could cause damage or leaks. Contact the closest *Canon Customer Support Help Desk* for immediate repair. The waterproof seal will be replaced on a chargeable basis.

Table of Contents

Package Contents	2	Safety Precautions	8
Compatible Memory Cards	2	Initial Preparations	11
Preliminary Notes and Legal Information	3	Trying the Camera Out.....	18
Part Names and Conventions in This Guide	4	Included Software, PDF Manuals...	23
Cautions When Using this Waterproof, Dustproof, and Shock Resistant Camera	6	Specifications	29
		Accessories	34

Safety Precautions

- Before using the product, please ensure that you read the safety precautions described below. Always ensure that the product is used correctly.
- The safety precautions noted on the following pages are intended to prevent injuries to yourself and other persons, or damage to the equipment.
- Be sure to also check the guides included with any separately sold accessories you use.



Warning

Denotes the possibility of serious injury or death.

- **Do not trigger the flash in close proximity to people's eyes.**
Exposure to the intense light produced by the flash could damage eyesight. In particular, remain at least one meter (39 inches) away from infants when using the flash.
- **Store this equipment out of the reach of children and infants.**
Strap: Putting the strap around a child's neck could result in asphyxiation.
- **Use only recommended power sources.**
- **Do not attempt to disassemble, alter or apply heat to the product.**
- **Avoid dropping or subjecting the product to severe impacts.**
- **To avoid the risk of injury, do not touch the interior of the product if it has been dropped or otherwise damaged.**
- **Stop using the product immediately if it emits smoke, a strange smell, or otherwise behaves abnormally.**
- **Do not use organic solvents such as alcohol, benzine, or thinner to clean the product.**
- **Do not allow liquids or foreign objects to enter the camera.**
This could result in electrical shock or fire.
If liquids or foreign objects come into contact with the camera interior, immediately turn the camera off and remove the battery.
If the battery charger becomes wet, unplug it from the outlet and consult your camera distributor or a Canon Customer Support Help Desk.

- **Use only the recommended battery.**
- **Do not place the battery near or in direct flame.**
- **Unplug the power cord periodically, and using a dry cloth, wipe away any dust and dirt that has collected on the plug, the exterior of the power outlet, and the surrounding area.**
- **Do not handle the power cord with wet hands.**
- **Do not use the equipment in a manner that exceeds the rated capacity of the electrical outlet or wiring accessories. Do not use if the power cord or plug are damaged, or not fully plugged into the outlet.**
- **Do not allow dirt or metal objects (such as pins or keys) to contact the terminals or plug.**

The battery may explode or leak, resulting in electrical shock or fire. This could cause injury and damage the surroundings. In the event that a battery leaks and the battery electrolyte contacts eyes, mouth, skin or clothing, immediately flush with water.

- **Turn the camera off in places where camera use is prohibited.**

The electromagnetic waves emitted by the camera may interfere with the operation of electronic instruments and other devices. Exercise adequate caution when using the camera in places where use of electronic devices is restricted, such as inside airplanes and medical facilities.

- **Do not play the supplied CD-ROM(s) in any CD player that does not support data CD-ROMs.**

It is possible to suffer hearing loss from listening with headphones to the loud sounds of a CD-ROM played on an audio CD player (music player). Additionally, this could damage the speakers.

- **Do not use the optional shoulder strap or carabiner strap while under water.** Straps that accidentally wrap around your neck pose a risk of asphyxiation.



Caution

Denotes the possibility of injury.

- **When holding the camera by the strap, be careful not to bang it, subject it to strong impacts or shocks, or let it get caught on other objects.**

This could lead to injury or damage the camera.

- **Be careful not to subject the screen to strong impacts.**

If the screen cracks, injury may result from the broken fragments.

- **When using the flash, be careful not to cover it with your fingers or clothing.**

This could result in burns or damage to the flash.

- **Avoid using, placing or storing the product in the following places:**

- **Places subject to strong sunlight**
- **Places subject to temperatures above 40 °C (104 °F)**
- **Humid or dusty areas**

These could cause leakage, overheating or an explosion of the battery, resulting in electrical shock, fire, burns or other injuries.

High temperatures may cause deformation of the camera or battery charger casing.

- Viewing images on the camera screen for prolonged periods may cause discomfort.

Caution

Denotes the possibility of damage to the equipment.

- **Do not aim the camera at bright light sources (such as the sun on a clear day).**
Doing so may damage the image sensor.

- **This camera cannot be used underwater at a depth greater than 10 m (33 ft.), or in hot springs and other mineralized waters.**

This may cause damage or water leakage.

- **When using the camera on a beach or at a windy location, be careful not to allow dust or sand to enter the camera.**

This may cause the product to malfunction.

- **In regular use, small amounts of smoke may be emitted from the flash.**

This is due to the high intensity of the flash burning dust and foreign materials stuck to the front of the unit. Please use a cotton swab to remove dirt, dust or other foreign matter from the flash to prevent heat build-up and damage to the unit.

- **Remove and store the battery when you are not using the camera.**

If the battery is left inside the camera, damage caused by leakage may occur.

- **Keep the covers closed when the camera is not in use.**

Storing the camera with the covers open may damage it if liquid or dust gets inside.

- **Before you discard the battery, cover the terminals with tape or other insulators.**
Contacting other metal materials may lead to fire or explosions.

- **Unplug the battery charger from the power outlet after charging is complete, or when you are not using it.**

- **Do not place anything, such as cloth, on top of the battery charger while it is charging.**

Leaving the unit plugged in for a long period of time may cause it to overheat and distort, resulting in fire.

- **Do not place the battery near pets.**

Pets biting the battery could cause leakage, overheating or explosion, resulting in fire or damage.

- **When putting the camera in your bag, ensure that hard objects do not come into contact with the screen.**

- **Do not attach any hard objects to the camera.**

Doing so may cause malfunctions or damage the screen.



Initial Preparations

Prepare for shooting as follows.

Attaching the Strap

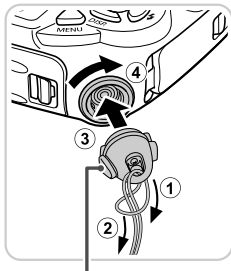

Release Button

Attach the strap.

- After attaching the strap to the strap mount, insert the strap mount into the socket on the camera and turn until it clicks.
- To remove the strap mount, hold the release button while turning the strap mount counterclockwise.

Holding the Camera



- To avoid dropping the camera, be sure to place the strap around your wrist when shooting. This camera will sink in water.
- When shooting, keep your arms close to your body and hold the camera securely to prevent it from moving. Do not rest your fingers on the flash.

Charging the Battery

Before use, charge the battery with the included charger. Be sure to charge the battery initially, because the camera is not sold with the battery charged.

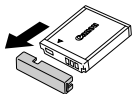

1 Remove the cover.

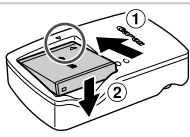

2 Insert the battery.

- After aligning the ▲ marks on the battery and charger, insert the battery by pushing it in (①) and down (②).

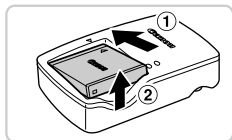
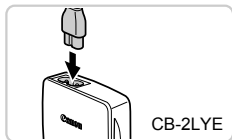
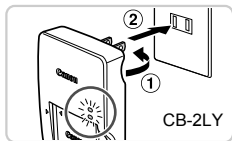

3 Charge the battery.

- **For CB-2LY:** Flip out the plug (①) and plug the charger into a power outlet (②).
- **For CB-2LYE:** Plug the power cord into the charger, then plug the other end into a power outlet.
 - ▶ The charging lamp turns orange and charging begins.
 - ▶ When the charging is finished, the lamp turns green.

4 Remove the battery.

- After unplugging the battery charger, remove the battery by pushing it in (①) and up (②).



- To protect the battery and keep it in optimal condition, do not charge it continuously for more than 24 hours.
- For battery chargers that use a power cord, do not attach the charger or cord to other objects. Doing so could result in malfunction or damage to the product.



- For details on charging time and the number of shots and recording time possible with a fully charged battery, see "Specifications" (p. 29).

Inserting the Battery and Memory Card

Insert the included battery and a memory card (sold separately). Note that before using a new memory card (or a memory card formatted in another device), you should format the memory card with this camera (see *Camera User Guide*).

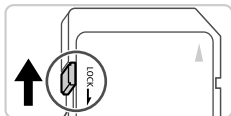

1 Check the card's write-protect tab.

- Recording is not possible on memory cards with a write-protect tab when the tab is in the locked (downward) position. Slide the tab up until it clicks into the unlocked position.

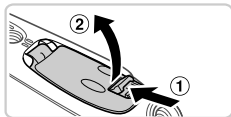

2 Open the cover.

- Slide the switch (1) and open the cover (2).

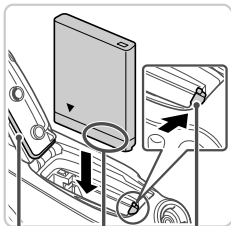

3 Insert the battery.

- While pressing the battery lock in the direction of the arrow, insert the battery facing as shown and push it in until it clicks into the locked position.
- Batteries inserted facing the wrong way cannot be locked into the correct position. Always confirm that the battery is facing the right way and locks when inserted.
- Be careful not to damage the waterproof seal when inserting the battery.

Terminals
Waterproof Seal
Battery Lock

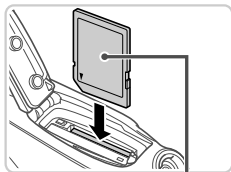

4 Insert the memory card.

- Insert the memory card facing as shown until it clicks into the locked position.
- Make sure the memory card is facing the right way when you insert it. Inserting memory cards facing the wrong way may damage the camera.
- Be careful not to damage the waterproof seal when inserting the memory card.

Label

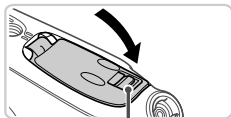

Red Mark

5 Close the cover.

- Lower the cover in the direction of the arrow and press it until it clicks into the closed position.
- Make sure the lock returns to the position shown, with the red mark no longer visible.



- Do not open the covers when the camera is wet or submerged in water. If there is moisture on the camera, wipe it off with a soft, dry cloth until it is completely dry.
- Be sure that the waterproof seals and the areas around them are kept free from scratches and foreign objects such as sand, dirt, or hair. Not doing so may result in leaks.
- Avoid opening and closing the covers while on the beach or near water. Change memory cards and batteries in a dry place protected from sea breezes.

Removing the Battery and Memory Card

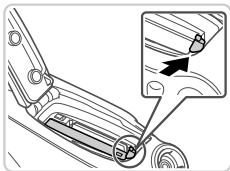

Remove the battery.

- Open the cover and press the battery lock in the direction of the arrow.
- ▶ The battery will pop up.

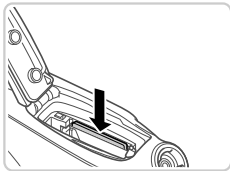

Remove the memory card.

- Push the memory card in until it clicks, and then slowly release it.
- ▶ The memory card will pop up.

Setting the Date and Time

A screen for setting the date and time is displayed the first time you turn the camera on. Be sure to specify the date and time, which is the basis for dates and times added to your images.

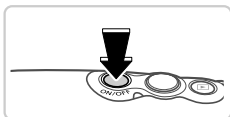

1 Turn the camera on.

- Press the power button.
- ▶ The [Date/Time] screen is displayed.

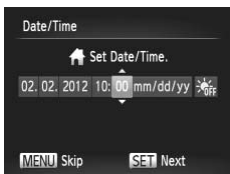

2 Set the date and time.

- Press the ◀▶ buttons to choose an option.
- Press the ▲▼ buttons to specify the date and time.
- When finished, press the  button.

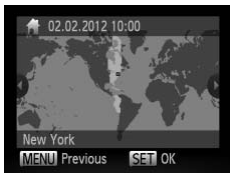
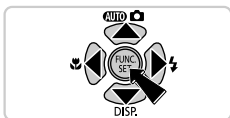

3 Set the local time zone.

- Press the ◀▶ buttons to choose your local time zone.

4 Finish the setup process.

- Press the  button when finished. After a confirmation message, the setting screen is no longer displayed.
- To turn off the camera, press the power button.

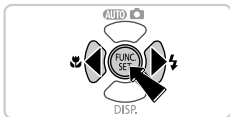

- ⓘ Unless you set the date, time, and local time zone, the [Date/Time] screen will be displayed each time you turn the camera on. Specify the correct information.

-  To set daylight saving time (1 hour ahead), choose ☀_{OFF} in step 2 and then choose ☀ by pressing the ▲▼ buttons.

▼ Changing the Date and Time

Adjust the date and time as follows.

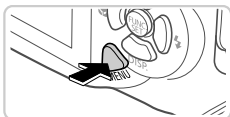

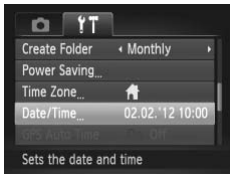

1 Access the camera menu.

- Press the **MENU** button.





2 Choose [Date/Time].

- Press the zoom buttons to choose the  tab.
- Press the ▲▼ buttons to choose [Date/Time], and then press the  button.

3 Change the date and time.

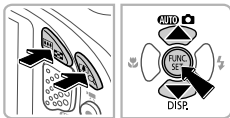
- Follow step 2 on p. 15 to adjust the settings.
- Press the **MENU** button to close the menu.



-  Date/time settings can be retained for about 3 weeks by the camera's built-in date/time battery (backup battery) after the battery pack is removed.
- The date/time battery will be charged in about 4 hours once you insert a charged battery or connect the camera to an AC adapter kit (sold separately, see *Camera User Guide*), even if the camera is left off.
- Once the date/time battery is depleted, the [Date/Time] screen will be displayed when you turn the camera on. Follow the steps on p. 15 to set the date and time.
- Automatic date and time updating is possible using GPS (see *Camera User Guide*).

Display Language

The display language can be changed as needed.

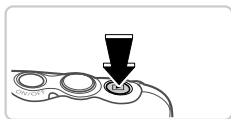

1 Enter Playback mode.

- Press the button.



2 Access the setting screen.

- Press and hold the button, and then immediately press the **MENU** button.



3 Set the display language.

- Press the buttons to choose a language, and then press the button.
- ▶ Once the display language has been set, the setting screen is no longer displayed.

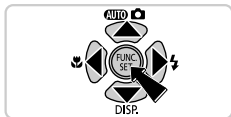

- The current time is displayed if you wait too long in step 2 after pressing the button before you press the **MENU** button. In this case, press the button to dismiss the time display and repeat step 2.
- You can also change the display language by pressing the **MENU** button and choosing [Language] on the tab.

Trying the Camera Out

Follow these instructions to turn the camera on, shoot still images or movies, and then view them.

Shooting (Smart Auto)

For fully automatic selection of the optimal settings for specific scenes, simply let the camera determine the subject and shooting conditions.



Red Mark

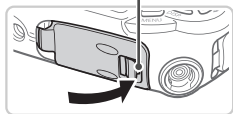

1 Make sure the covers are closed.

- Make sure that both the memory card/battery cover lock and terminal cover lock return to the positions shown, with the red marks no longer visible.
- If either cover is not fully closed, water may enter the camera when it gets wet, which may damage it.

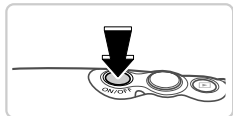

2 Turn the camera on.

- Press the power button.
- ▶ The startup screen is displayed.

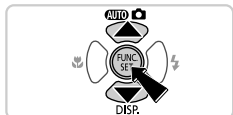



3 Enter **AUTO** mode.

- Press the **▲** button, press the **▲▼** buttons to choose **AUTO**, and then press the **FUNC. SET** button.
- ▶ Icons representing the scene and image stabilization mode are displayed in the upper right of the screen.
- ▶ Frames displayed around any subjects that are detected indicate that they are in focus.

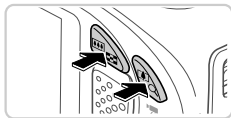



4 Compose the shot.

- To zoom in and enlarge the subject, press the  (telephoto) zoom button, and to zoom away from the subject, press the  (wide angle) zoom button.

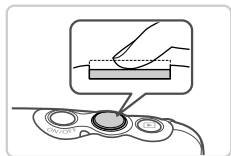

5 Shoot.

Shooting Still Images

① Focus.

- Press the shutter button lightly, halfway down. The camera beeps twice after focusing, and AF frames are displayed to indicate image areas in focus.

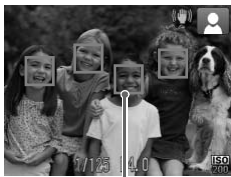

AF Frames

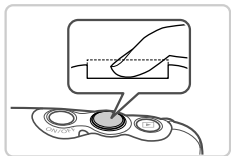

② Shoot.

- Press the shutter button all the way down.
- As the camera shoots, a shutter sound is played, and in low-light conditions, the flash fires automatically.
- Your shot remains displayed on the screen for about two seconds.
- Even while the shot is displayed, you can take another shot by pressing the shutter button again.

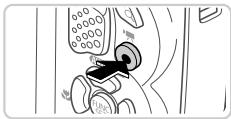

Elapsed Time

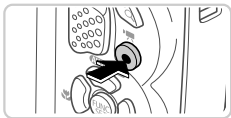

Shooting Movies

① Start shooting.

- Press the movie button. The camera beeps once as recording begins, and [● Rec] is displayed with the elapsed time.
- ▶ Black bars displayed on the top and bottom edges of the screen indicate image areas not recorded.
- Once recording begins, you can take your finger off the movie button.

② Finish shooting.

- Press the movie button again to stop shooting. The camera beeps twice as recording stops.
- ▶ Recording will stop automatically when the memory card becomes full.

Viewing

After shooting images or movies, you can view them on the screen as follows.

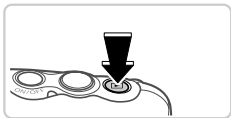



1 Enter Playback mode.

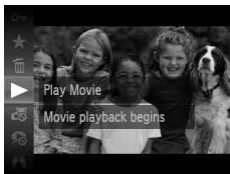
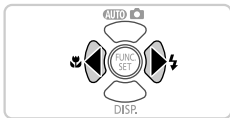

- Press the  button.
- ▶ Your last shot is displayed.



2 Browse through your images.

- To view the previous image, press the ◀ button. To view the next image, press the ▶ button.
- To access Scroll Display mode, press and hold the ◀▶ buttons for at least one second. In this mode, press the ◀▶ buttons to browse through images.
- To return to single-image display, press the  button.
- To browse images grouped by shooting date, press the ▲▼ buttons in Scroll Display mode.
- Movies are identified by a  icon. To play movies, go to step 3.

3 Play movies.

- Press the  button, press the ▲▼ buttons to choose ▶, and then press the  button again.
- ▶ Playback now begins, and after the movie is finished,  is displayed.
- To adjust the volume, press the ▲▼ buttons.



- To switch to Shooting mode from Playback mode, press the shutter button halfway.

Erasing the Images





You can choose and erase unneeded images one by one. Be careful when erasing images, because they cannot be recovered.

1 Choose an image to erase.

- Press the ◀▶ buttons to choose an image.



2 Erase the image.

- Press the  button, press the ▲▼ buttons to choose , and then press the  button again.
- After [Erase?] is displayed, press the ◀▶ buttons to choose [Erase], and then press the  button.
- ▶ The current image is now erased.
- To cancel erasure, press the ◀▶ buttons to choose [Cancel], and then press the  button.

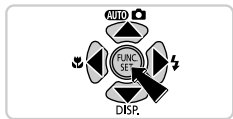

- You can also erase all images at once (see *Camera User Guide*).



Included Software, PDF Manuals

The software and PDF manuals on the included CD-ROM are introduced below, with instructions for installation, saving images to a computer, and using the PDF manuals.

Features of the Included Software

After installing the software on the CD-ROM, you can do the following things on your computer.

ImageBrowser EX

- Import images and change camera settings
- Manage images: view, search, and organize
- Print and edit images
- Update to the latest software version with the auto update function

Auto Update Function

Using the included software, you can update to the latest version, and download new functions via the Internet (some software excluded). Be sure to install the software on a computer with an Internet connection so you can use this function.



- Internet access is required to use this function, and any ISP account charges and access fees must be paid separately.
- This function may not be available depending on the camera or region you live in.

PDF Manuals

Installing the software on the CD-ROM will also install the following PDF manuals on your computer.

Camera User Guide

Once you are familiar with the information in this manual, refer to this for a more in-depth understanding of camera operation.

ImageBrowser EX User Guide

Refer to this guide when using the included software.

This guide can be referenced from the ImageBrowser EX Help function.



- Depending on the country or region where you purchased your camera, the *ImageBrowser EX User Guide* may not be accessible from the Help function. In such cases, it will either be included on the CD-ROM bundled with your camera, or you can download the latest version from the Canon website.

System Requirements

The included software can be used on the following computers. Adobe Reader is required to view the PDF manuals.

Windows

Operating System	Windows 7 SP1 Windows Vista SP2 Windows XP SP3
Computer	Computers running one of the above operating systems (preinstalled), with an included USB port and Internet connection
Processor	Still images: 1.6 GHz or higher, Movies: Core 2 Duo 2.6 GHz or higher
RAM	Windows 7 (64 bit): 2 GB or more Windows 7 (32 bit), Windows Vista (64 bit, 32 bit): 1 GB or more (still images), 2 GB or more (movies) Windows XP: 512 MB or more (still images), 2 GB or more (movies)
Interfaces	USB
Free Hard Disk Space	440 MB or more*
Display	1024 x 768 resolution or higher

* In Windows XP, Microsoft .NET Framework 3.0 or later (max. 500 MB) must be installed. Installation may take some time, depending on computer performance.

Macintosh

Operating System	Mac OS X 10.6
Computer	Computers running one of the above operating systems (preinstalled), with an included USB port and Internet connection
Processor	Still images: Core Duo 1.83 GHz or higher, Movies: Core 2 Duo 2.6 GHz or higher
RAM	1 GB or more (still images), 2 GB or more (movies)
Interfaces	USB
Free Hard Disk Space	550 MB or more
Display	1024 x 768 resolution or higher



* Check the Canon website for the latest system requirements, including supported OS versions.

Installing the Software and PDF Manuals

Windows 7 and Mac OS X 10.6 are used here for the sake of illustration. Using the software auto update function, you can update to the latest version and download new functions via the Internet (some software excluded), so be sure to install the software on a computer with an Internet connection.

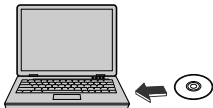

1 Insert the CD-ROM in the computer's CD-ROM drive.

- Insert the included CD-ROM (DIGITAL CAMERA Solution Disk) (p. 2) in the computer's CD-ROM drive.
- On a Macintosh computer, after inserting the disc, double-click the desktop disc icon to open it, and then double-click the  icon displayed.



2 Begin the installation.

- Click [Easy Installation] and follow the on-screen instructions to complete the installation process.



3 When a message is displayed prompting you to connect the camera, connect it to a computer.

- With the camera turned off, open the cover (①). With the smaller plug of the included interface cable (p. 2) in the orientation shown, insert the plug fully into the camera terminal (②).

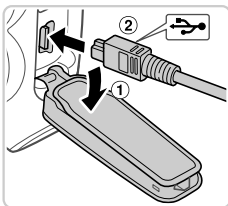

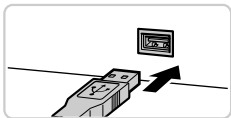

- Insert the larger plug of the interface cable in the computer's USB port. For details about USB connections on the computer, refer to the computer user manual.

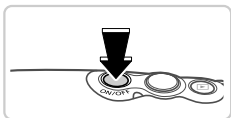

4 Install the files.



- Turn the camera on, and follow the on-screen instructions to complete the installation process.
- ▶ The software will connect to the Internet to update to the latest version and download new functions. Installation may take some time, depending on computer performance and the Internet connection.
- Click [Finish] or [Restart] on the screen after installation and remove the CD-ROM when the desktop is displayed.
- Turn the camera off and disconnect the cable.



- When not connected to the Internet, there are the following limitations.
 - The screen in step 3 will not be displayed.
 - Some functions may not be installed.
 - The first time you connect the camera to the computer, drivers will be installed, so it may take a few minutes until camera images are accessible.
- If you have several cameras that were bundled with ImageBrowser EX on the included CD-ROMs, be sure to use each camera with their included CD-ROM and follow the on-screen installation instructions for each. Doing so will ensure that each camera will receive the correct updates and new functions via the auto update function.

Saving Images to a Computer



Windows 7 and Mac OS X 10.6 are used here for the sake of illustration.

1 Connect the camera to the computer.

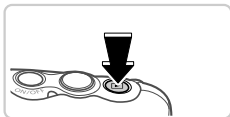
- Follow step 3 on p. 25 to connect the camera to a computer.



2 Turn the camera on to access CameraWindow.

- Press the  button to turn the camera on.
- On a Macintosh computer, CameraWindow is displayed when a connection is established between the camera and computer.
- For Windows, follow the steps introduced below.
- In the screen that displays, click the  link to modify the program.
- Choose [Downloads Images From Canon Camera using Canon CameraWindow] and then click [OK].



- Double click .

CameraWindow

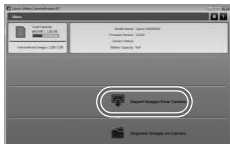

3 Save the images to the computer.

- Click [Import Images from Camera], and then click [Import Untransferred Images].
- ▶ Images are now saved to the Pictures folder on the computer, in separate folders named by date.
- After images are saved, close CameraWindow, press the  button to turn the camera off, and unplug the cable.
- For instructions on viewing images on a computer, refer to the *ImageBrowser EX User Guide* (p. 23).



- In Windows 7, if the screen in step 2 is not displayed, click the  icon in the taskbar.
- To start CameraWindow in Windows Vista or XP, click [Downloads Images From Canon Camera using Canon CameraWindow] on the screen displayed when you turn the camera on in step 2. If CameraWindow is not displayed, click the [Start] menu and choose [All Programs] ► [Canon Utilities] ► [CameraWindow] ► [CameraWindow].
- On a Macintosh computer, if CameraWindow is not displayed after step 2, click the [CameraWindow] icon in the Dock (the bar at the bottom of the desktop).
- Although you can save images to a computer simply by connecting your camera to the computer without using the included software, the following limitations apply.
 - It may take a few minutes after you connect the camera to the computer until camera images are accessible.
 - Images shot in vertical orientation may be saved in horizontal orientation.
 - Image protection settings may be cleared from images saved to a computer.
 - Some problems may occur when saving images or image information, depending on the operating system version, the software in use, or image file sizes.
 - GPS log files (see *Camera User Guide*) may not be saved correctly.
 - Some functions provided by the included software may not be available, such as editing movies or returning images to the camera.

Using the PDF Manuals

Use the included CD-ROM to install the PDF manuals, and a shortcut for the camera manual will be created on the desktop.

Adobe Reader is required to view the PDF manuals.



- It may not be possible to install the software and PDF manuals on computers that do not meet the system requirements (p. 24). To view the manuals on these computers, copy the PDF files in the Readme folder on the CD-ROM directly to a computer capable of using Adobe Reader.

Specifications

Camera Effective Pixels	Approx. 12.1 million pixels
Lens Focal Length	5x zoom: 5.0 (W) – 25.0 (T) mm (35mm film equivalent: 28 (W) – 140 (T) mm)
Waterproof Capability	IEC/JIS protection class "IPX8" equivalent*1 For use within a depth of 10 meters up to 60 minutes.
Dustproof Capability	IEC/JIS protection class "IP6X" equivalent*1
Shock Resistant Capability	Canon standard based on MIL Standard 810F Method 516.5 Selecting Procedure IV (A US Defense Standard)*1*2 cleared
LCD Monitor	3.0 type color TFT LCD Effective Pixels: Approx. 461,000 pixels
File Formats	Design rule for Camera File system, DPOF (version 1.1) compliant
Data Types	Still Images: Exif 2.3 (JPEG) Movies: MOV (H.264 video data, Linear PCM (2 channel monaural) audio data) GPS log files: NMEA 0183 message format compliant
Interfaces	Hi-speed USB HDMI output Analog audio output (monaural) Analog video output (NTSC/PAL)
Power	Battery Pack NB-6L AC Adapter Kit ACK-DC40
Operating Temperature*3	-10 – 40 °C (14 – 104 °F)
Dimensions (Based on CIPA Guidelines)	112.3 x 70.8 x 28.0 mm (4.42 x 2.79 x 1.10 in.)
Weight (Based on CIPA Guidelines)	Approx. 228 g (approx. 8.04 oz.; including battery and memory card) Approx. 205 g (approx. 7.23 oz.; camera body only)

*1 The camera is subjected to Canon standard testing conditions. However, it is not guaranteed that this camera will not be damaged or malfunction.

*2 Testing Conditions:

Drop height: 1.5 m (5 ft.).

Drop surface: Wood.

Drop direction: Each surface (6 surfaces), each angle (4 angles) for a total of 10.

Number of drops: Each surface and each angle 3 times for a total of 30.

*3 Performance of the NB-6L battery pack may decrease at temperatures between -10 to 0 °C (14 to 32 °F), as this is outside of the recommended temperature range. However, use of the battery is possible.

Number of Shots/Recording Time, Playback Time

Number of Shots	Approx. 280
Movie Recording Time*¹	Approx. 1 hour
Continuous Shooting*²	Approx. 1 hr. 40 min.
Playback Time	Approx. 5 hours

*1 Time under default camera settings, when normal operations are performed, such as shooting, pausing, turning the camera on and off, and zooming.

*2 Time available when shooting the maximum movie length (until recording stops automatically) repeatedly.





- The number of shots that can be taken is based on measurement guidelines of the Camera & Imaging Products Association (CIPA).
- Under some shooting conditions, the number of shots and recording time may be less than mentioned above.
- Number of shots/time with a fully charged battery.

Number of 4:3 Shots per Memory Card

	Resolution (Pixels)	No. Shots per Memory Card (Approx.)	
		8 GB	32 GB
L (Large)	12M/4000x3000	2505	10115
M1 (Medium 1)	6M/2816x2112	4723	19064
M2 (Medium 2)	2M/1600x1200	12927	52176
S (Small)	0.3M/640x480	40937	165225



- These values are measured according to Canon standards and may change depending on the subject, memory card and camera settings.
- Table values are based on images with a 4:3 aspect ratio. Changing the aspect ratio (see *Camera User Guide*) will enable more shots, because less data is used per image than for 4:3 images. However, with **M2**, 16:9 images have a resolution of 1920 x 1080 pixels, which requires more data than for 4:3 images.

Recording Time per Memory Card



Image Quality	Recording Time per Memory Card	
	8 GB	32 GB
	29 min. 39 sec.	1 hr. 59 min. 43 sec.
	42 min. 11 sec.* ¹	2 hr. 50 min. 19 sec.* ²
	1 hr. 28 min. 59 sec.	5 hr. 59 min. 10 sec.
	26 min. 24 sec.	1 hr. 46 min. 35 sec.
	52 min. 28 sec.	3 hr. 31 min. 49 sec.

*¹ 27 min. 39 sec. for iFrame movies (see *Camera User Guide*).

*² 1 hr. 51 min. 37 sec. for iFrame movies (see *Camera User Guide*).

- These values are measured according to Canon standards and may change depending on the subject, memory card and camera settings.
- Recording will automatically stop when the file size of an individual clip being recorded reaches 4 GB, or when the recording time reaches approximately 29 minutes and 59 seconds (for  or  movies) or approximately 1 hour (for  movies).
- On some memory cards, recording may stop before the maximum clip length has been reached. Speed Class 6 or higher memory cards are recommended.

Flash Range

Maximum wide angle ()	30 cm – 3.5 m (12 in. – 11 ft.)
Maximum telephoto ()	1.0 – 3.0 m (3.3 – 9.8 ft.)

Shooting Range

Shooting Mode	Focusing Range	Maximum Wide Angle ()	Maximum Telephoto ()
	–	1 cm (0.4 in.) – infinity	1 m (3.3 ft.) – infinity
	 MF	1 – 50 cm (0.4 in. – 1.6 ft.)	–
Other modes		5 cm (2.0 in.) – infinity	1 m (3.3 ft.) – infinity
		1 – 50 cm (0.4 in. – 1.6 ft.)	–
	MF*	1 cm (0.4 in.) – infinity	1 m (3.3 ft.) – infinity

* Not available in some shooting modes.

- Approximately 1.3x for underwater shots.

Continuous Shooting Speed

Approx. 1.9 shots/sec.

Shutter Speed

AUTO mode, automatically set range	1 – 1/1600 sec.
Range in all shooting modes	15 – 1/1600 sec.

Aperture

f/number	f/3.9, f/8.0 (W), f/4.8, f/10 (T)
----------	-----------------------------------

Battery Pack NB-6L

Type	Rechargeable lithium-ion battery
Rated Voltage	3.7 V DC
Rated Capacity	1000 mAh
Charging Cycles	Approx. 300 times
Operating Temperature	0 – 40 °C (32 – 104 °F)
Dimensions	34.4 x 41.8 x 6.9 mm (1.35 x 1.65 x 0.27 in.)
Weight	Approx. 21 g (approx. 0.74 oz.)

Battery Charger CB-2LY/CB-2LYE

Rated Input	100 – 240 V AC (50/60 Hz), 0.085 A (100 V) – 0.05 A (240 V)
Rated Output	4.2 V DC, 0.7 A
Charging Time	Approx. 1 hour 55 min. (when using NB-6L)
Charge Indicator	Charging: orange / Fully charged: green (two-indicator system)
Operating Temperature	0 – 40 °C (32 – 104 °F)
Dimensions	58.6 x 86.4 x 24.1 mm (2.31 x 3.40 x 0.95 in.)
Weight	Approx. 70 g (approx. 2.47 oz.) (CB-2LY) Approx. 61 g (approx. 2.15 oz.) (CB-2LYE, excluding power cord)

- All data is based on tests by Canon.
- Camera specifications or appearance are subject to change without notice.

CAUTION

RISK OF EXPLOSION IF BATTERY IS REPLACED BY AN INCORRECT TYPE.
DISPOSE OF USED BATTERIES ACCORDING TO LOCAL REGULATION.

FCC Notice

(Digital Camera, Model PC1734 systems)

This device complies with Part 15 of the FCC Rules. Operation is subject to the following two conditions;

- (1) this device may not cause harmful interference, and
- (2) this device must accept any interference received, including interference that may cause undesired operation.

Note: This equipment has been tested and found to comply with the limits for Class B digital devices, pursuant to Part 15 of the FCC rules. These limits are designed to provide reasonable protection against harmful interference in a residential installation. This equipment generates, uses and can radiate radio frequency energy and, if not installed and used in accordance with the instructions, may cause harmful interference to radio communications. However, there is no guarantee that interference will not occur in a particular installation. If this equipment does cause harmful interference to radio or television reception, which can be determined by turning the equipment off and on, the user is encouraged to try to correct the interference by one or more of the following measures:

- Reorient or relocate the receiving antenna.
- Increase the separation between the equipment and receiver.
- Connect the equipment into an outlet on a circuit different from that to which the receiver is connected.
- Consult the dealer or an experienced radio/TV technician for help.

The cable with the ferrite core provided with the digital camera must be used with this equipment in order to comply with Class B limits in Subpart B of Part 15 of the FCC rules.

Do not make any changes or modifications to the equipment unless otherwise specified in the manual. If such changes or modifications should be made, you could be required to stop operation of the equipment.

Canon U.S.A., Inc.

One Canon Plaza, Lake Success, NY 11042, U.S.A.

Tel No. (516) 328-5600

Canadian Radio Interference Regulations

This Class B digital apparatus complies with Canadian ICES-003.



USA and Canada only:

The Lithium ion/polymer battery that powers the product is recyclable. Please call 1-800-8-BATTERY for information on how to recycle this battery.

For CA, USA only

Included lithium battery contains Perchlorate Material - special handling may apply. See www.dtsc.ca.gov/hazardouswaste/perchlorate/ for details.

Accessories

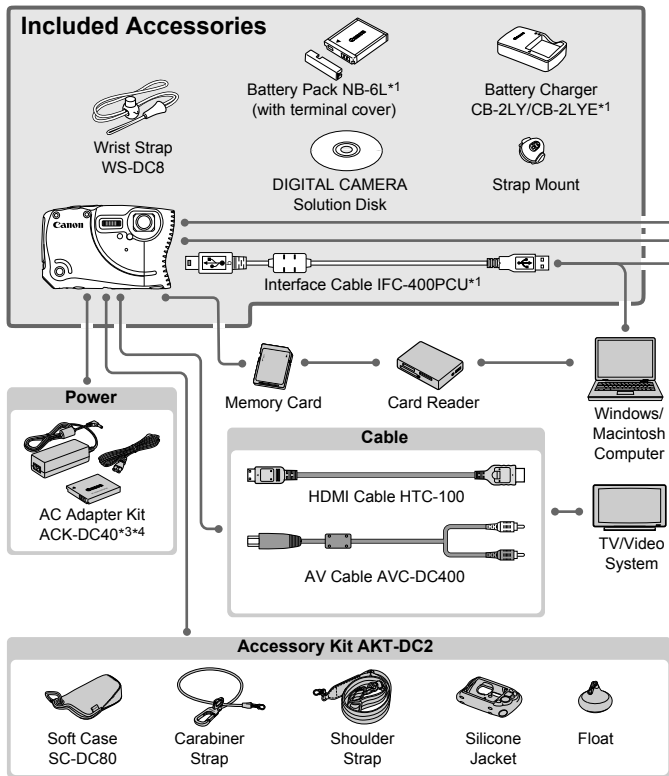

*1 Also available for purchase separately.

*2 High-Power Flash HF-DC1 also supported.

*3 The included DC coupler is not used.

*4 These accessories can also be used with the camera: ACK-DC10, ACK-DC30, ACK-DC60, ACK-DC70, ACK-DC80, and ACK-DC90.

Flash Unit

High-Power Flash
HF-DC2*2

Cases

Waterproof Case
WP-DC45



Soft Case
SC-DC80

Canon PictBridge-Compatible Printers**Use of genuine Canon accessories is recommended.**

This product is designed to achieve excellent performance when used with genuine Canon accessories.

Canon shall not be liable for any damage to this product and/or accidents such as fire, etc., caused by the malfunction of non-genuine Canon accessories (e.g., a leakage and/or explosion of a battery pack). Please note that this warranty does not apply to repairs arising out of the malfunction of non-genuine Canon accessories, although you may request such repairs on a chargeable basis.

Battery Charger CB-2LY

**IMPORTANT SAFETY INSTRUCTIONS-
SAVE THESE INSTRUCTIONS.**

**DANGER-TO REDUCE THE RISK OF FIRE
OR ELECTRIC SHOCK, CAREFULLY
FOLLOW THESE INSTRUCTIONS.**

For connection to a supply not in the U.S.A., use an attachment plug adapter of the proper configuration for the power outlet, if needed.

This Category II radiocommunication device complies with Industry Canada Standard RSS-310.

Operation is subject to the following two conditions: (1) this device may not cause interference, and (2) this device must accept any interference, including interference that may cause undesired operation of the device

In certain countries and regions, the use of GPS may be restricted. Therefore, be sure to use GPS in accordance with the laws and regulations of your country or region. Be particularly careful when traveling outside your home country.

Trademark Acknowledgments

- The SDXC logo is a trademark of SD-3C, LLC.
- This device incorporates exFAT technology licensed from Microsoft.
- HDMI, the HDMI logo and High-Definition Multimedia Interface are trademarks or registered trademarks of HDMI Licensing LLC.
- The iFrame logo and the iFrame symbol are trademarks of Apple Inc.

About MPEG-4 Licensing

This product is licensed under AT&T patents for the MPEG-4 standard and may be used for encoding MPEG-4 compliant video and/or decoding MPEG-4 compliant video that was encoded only (1) for a personal and non-commercial purpose or (2) by a video provider licensed under the AT&T patents to provide MPEG-4 compliant video.

No license is granted or implied for any other use for MPEG-4 standard.

* Notice displayed in English as required.

Disclaimer

- Reprinting, transmitting, or storing in a retrieval system any part of this guide without the permission of Canon is prohibited.
- Canon reserves the right to change the contents of this guide at any time without prior notice.
- Illustrations and screenshots in this guide may differ slightly from the actual equipment.
- The above items notwithstanding, Canon accepts no liability for damages due to mistaken operation of the products.