

PIXMA MX850_{series}

Network Setup Guide

This manual contains the setup information required to use the machine over wired LAN.

If you use the machine with USB connection, refer to your setup sheet.

Table of Contents

Setup Outline

Setting Up the Machine and the Computer (Windows)	1
1 Preparing for Setup	2
2 Installing the Software	3
2-1 Setting Up for Use over Wired LAN	6
2-2 Setting Up an Additional LAN-connected Computer	11
Setting Up the Machine and the Computer (Macintosh)	16
1 Preparing for Setup	17
2 Installing the Software	18
2-1 Setting Up for Use over Wired LAN	23
2-2 Setting Up an Additional LAN-connected Computer	27
Troubleshooting	30
Cannot Install the MP Drivers	31
Cannot Connect to the Machine (the machine is not detected)	32
The Following Screen Is Displayed during Setup	33
Setting Up the Machine Again for Use over Network	37
Changing the Port Name (Windows)	37
Checking Information about the Network	38



Setup Outline

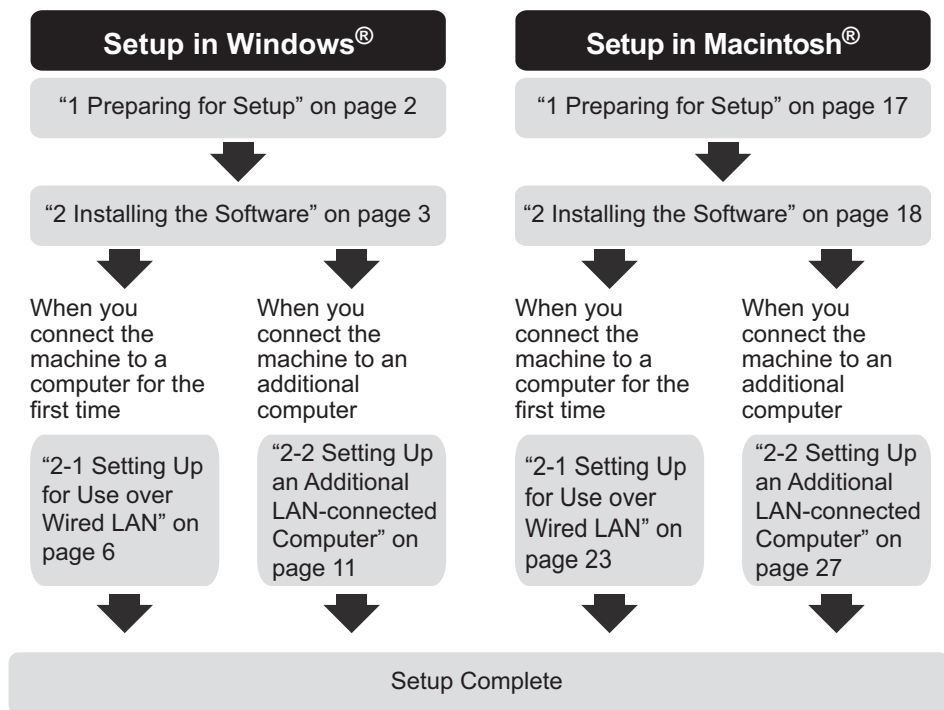

If any problem occurs during the setup, see “Troubleshooting” on page 30.

■ Symbols Used in This Manual

This *Network Setup Guide* uses the following symbols to indicate important information. Always observe the instructions indicated by these symbols.

 **Important** Instructions that must be observed for safe operation.

 **Note** Instructions as notes for operation or additional explanations.

 **Windows** Indicates operations in Windows.

 **Macintosh** Indicates operations in Macintosh.

■ Trademarks

- “Microsoft” is a registered trademark of Microsoft Corporation.
- “Windows” is a trademark of Microsoft Corporation, registered in the U.S. and other countries.
- “Windows Vista” is a trademark of Microsoft Corporation.
- “Macintosh” and “Mac” are trademarks of Apple Inc., registered in the U.S. and other countries.
- “Ethernet” is a trademark of Xerox Corporation.

© CANON INC. 2008

All rights reserved. No part of this publication may be transmitted or copied in any form whatsoever without the express written permission.

Setting Up the Machine and the Computer (Windows)

To use the machine connected to a computer, you need to install the software called “MP Drivers” in the computer.

The following two connection types are described in this manual.

Setting Up for Use over Wired LAN

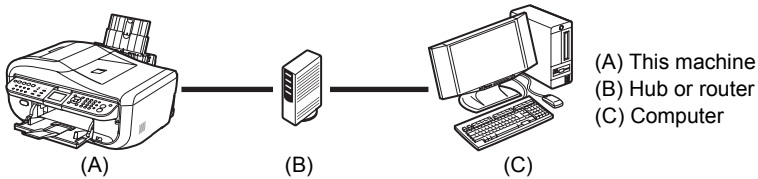

When the machine has not been connected to the network, perform this setup to use the machine over wired LAN. This setup procedure requires settings to be performed on the machine and the computer.

Note

- To set up the machine that is not yet connected to a wired LAN, connect the machine and the computer with a USB cable.
- Even if the machine has been set up to be used with the USB connection, follow the setup procedure described in this manual to connect the machine to a wired LAN for the first time.

Setting Up an Additional LAN-connected Computer

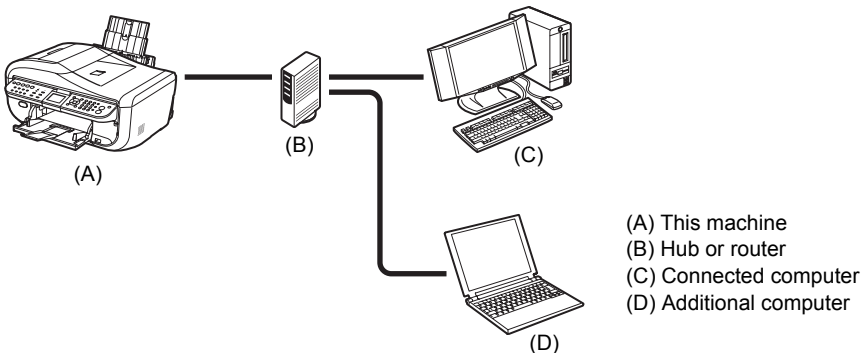

When the machine has already been set up to connect to the network, perform this setup to use the machine from an additional computer over wired LAN. This setup procedure only requires settings to be performed on the additional computer.

1 Preparing for Setup

Before installing the MP Drivers in your computer, make sure of the following.

- If the installation and adjustment of the machine have not been finished, refer to your setup sheet to set up the machine properly.
- Turn off the firewall function temporarily or change its setting. If you disable the firewall function, disconnect your network from the Internet.

For information on the firewall function of your security software, refer to its instruction manual or contact its manufacturer.

Important

After setup is complete, turn back on the firewall function you disabled for setup.

If you connect to a network that is not protected with security measures, there is a risk of disclosing data such as your personal information to a third party.

- Make sure that the configuration of computers, hubs, and other network devices is complete, and computers can connect to the network.

The configuration and the type of the device vary depending on your network environment. For details, refer to your device's instruction manual or contact its manufacturer.

Important

A hub and LAN cable are required to connect this machine to a wired LAN. These must be purchased separately.

Important

Depending on the country or region of purchase, the following two CD-ROMs are included in the package for the Windows setup.

- Windows (CD-1)
- Windows (CD-2) Macintosh

In this case, insert the *Setup CD-ROM* "Windows (CD-1)" first to start the installation, and follow the on-screen instructions to complete the installation.

Note

- In an office setup, consult your network administrator.
- Quit all running applications before installation.
- Log into a user account with the administrator privilege.
- Do not switch user accounts during installation.
- A message asking for your confirmation to restart your computer may appear during the installation process. If this message is displayed, follow the on-screen instructions and click **OK**.
The installation resumes from where it left off when your computer has been restarted. While restarting, do not remove the *Setup CD-ROM*.

The screens in this manual refer to Windows Vista™ operating system Ultimate Edition (hereafter referred to as "Windows Vista") installation. Screens may vary depending on the operating system you are using and also depending on the country or region of purchase.

2 Installing the Software

Note

If the **Found New Hardware** or **Found New Hardware Wizard** screen appears automatically during the installation process, remove the USB cable connected to your computer. Click **Cancel** to quit the screen. In Windows Vista, the screen may close automatically when the USB cable is unplugged. Then turn off the machine and proceed from step 3 to install the software.



- 1 Turn off the machine.

Note

Confirm that all the lamps on the Operation Panel have gone out.

- 2 Turn the computer on and start Windows.

- 3 Insert the *Setup CD-ROM*.

The setup program should run automatically.

If the setup program does not run automatically, see "Installation does not start automatically when the *Setup CD-ROM* is inserted into your computer's disc drive." in "Cannot Install the MP Drivers" on page 31.

In Windows Vista, go to step 4.

In Windows XP and Windows 2000, go to step 6.

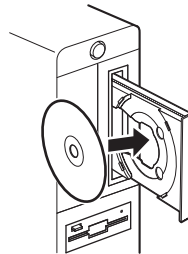

Important

If two CD-ROMs are included in the package for the Windows setup, insert the *Setup CD-ROM* "Windows (CD-1)".

Note

- If the **Select Language** screen appears, select a language, then click **Next**.
- If the **Select Your Place of Residence** screen appears, select your place of residence, then click **Next**.

4 If the **AutoPlay** screen appears, click **Run Msetup4.exe**.

This screen will not appear in Windows XP and Windows 2000.



5 If the **User Account Control** screen appears, click **Continue**.

If the same screen reappears in subsequent steps, click **Continue**.

This screen will not appear in Windows XP and Windows 2000.

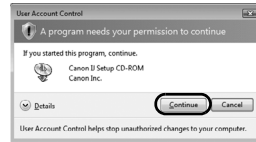

Note

- If the **Select Language** screen appears, select a language, then click **Next**.
- If the **Select Your Place of Residence** screen appears, select your place of residence, then click **Next**.

6 When the screen shown on the right appears, click **Easy Install**.

The MP Drivers, On-screen Manuals, and application software are installed automatically.

Note

If you want to select particular items to install, click **Custom Install** and follow the on-screen instructions to proceed with the installation.



7 When the **Easy Install** screen appears, confirm the contents, then click **Install**.

Note

- Move the cursor over items to display explanations of each application.
- The list of applications may vary depending on the country or region of purchase.

Users in Asia

- Scan Soft OmniPage SE can be installed only on an English operating system.

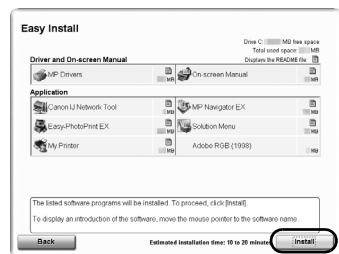

8 Read the License Agreement carefully and click **Yes**.

Installation of the MP Drivers, On-screen Manuals, and application software will begin.

The software installation screen may appear during the installation process. Read the contents on the screen and follow the on-screen instructions to install the software.

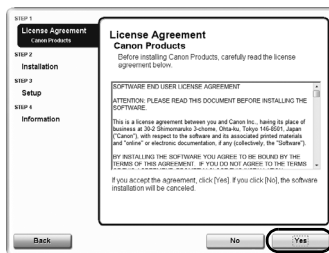

9 When the **Setup Method** screen appears, confirm the connection type.

The next procedure varies depending on how you intend to connect the machine and the computer.

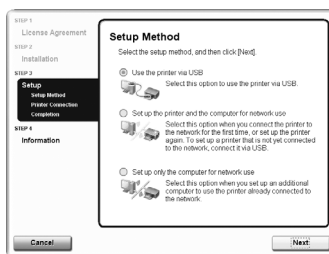

When you connect the machine to a computer for the first time

See “2-1 Setting Up for Use over Wired LAN” on page 6.

When the machine has not been connected to the network, perform this setup to use the machine over wired LAN. This setup procedure requires settings to be performed on the machine and the computer.

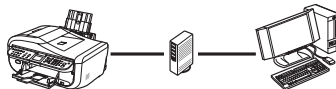

When you connect the machine to an additional computer

See “2-2 Setting Up an Additional LAN-connected Computer” on page 11.

When the machine has already been set up to connect to the network, perform this setup to use the machine from an additional computer over wired LAN. This setup procedure only requires settings to be performed on the additional computer.

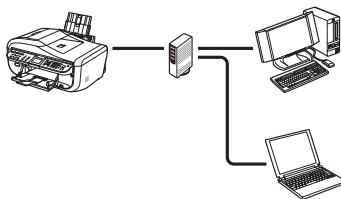

2-1 Setting Up for Use over Wired LAN

(continued from step 9 on page 5)

Important

When the machine has not been connected to the network, to set up the machine to be used from a LAN-connected computer, the necessary software must be installed on the computer. See “1 Preparing for Setup” on page 2 and “2 Installing the Software” on page 3 to confirm that the software installation is complete, then proceed with the procedure below.

- 1 On the **Setup Method** screen, select **Set up the printer and the computer for network use**, then click **Next**.

Note

If you select **Use the printer via USB**, the machine is set up to be used with USB connection.

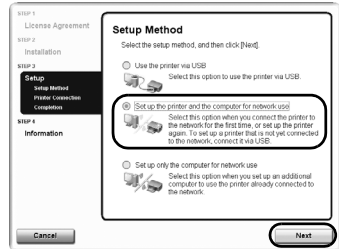

- 2 When the **Printer Connection** screen appears, connect the machine to the computer with a USB cable, then turn on the machine.

When you turn on the machine, the **COPY** button flashes green, then remains lit.

When the computer detects the machine, the next screen will appear automatically.

Note

- To set up the machine that is not yet connected to a wired LAN, connect the machine and the computer with a USB cable.
- If you cannot go to the next procedure after three minutes, see “Cannot Install the MP Drivers” on page 31.

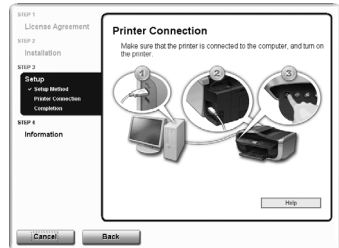

- 3 When the **Setup Preparations** dialog box appears, confirm that preparation is complete, then click **Next**.

Note

If the machine’s network settings are already configured, the **Setup Environment Confirmation** dialog box appears asking for your confirmation to use the machine with the current settings. You can proceed with the setup using the current network settings. To do so, click **Use it as is**. To reconfigure the network settings, click **Reconfigure**.

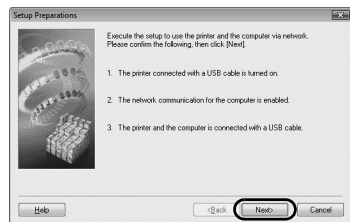

4 When the **Check Wired LAN Connection** dialog box appears, remove the LAN connector cap, connect the machine to the network devices such as hubs with a LAN cable, then click **Yes**.

- (A) Wired LAN connector
- (B) LAN connector cap

Note

The connection may vary depending on your network environment.

The machine connected with the USB cable is detected automatically via LAN connection.

In Windows Vista, go to step 6.

In Windows XP and Windows 2000, go to step 5.

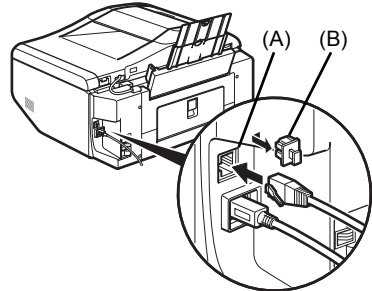

Note

If the machine was not detected, the **Set Printer IP Address** dialog box appears. Make sure of the following, then click **Connect**.

- The network devices such as hubs or routers are turned on, and the machine and the computer are connected to the network.
- The machine is connected to the computer with the USB cable.
- The IP address to be set for the machine is displayed on the **Set Printer IP Address** dialog box.

If it is different from the address you want to set for the machine, select **Use next IP address** and enter the desired IP address.

(If the machine is turned off, the **Set Printer IP Address** dialog box does not appear.)

If it still fails, see "The Set Printer IP Address dialog box is displayed" on page 33.

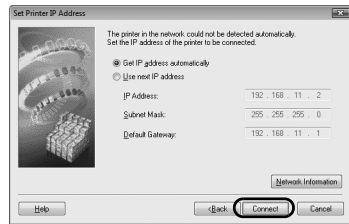

- 5** When the **Network Setup of the Card Slot** dialog box appears, specify the drive letter, then click **Next**.

This screen will not appear in Windows Vista.

Note

- The Card Slot of the machine must be mounted to be used as the memory card drive of the LAN-connected computer.
To write files to a memory card, set the **Read/write attribute** setting under **Device settings** to **LAN enabled**. If the setting is set to **USB enabled**, you cannot access the network drive of the Card Slot.
- If **“Communication with the Card Slot failed.”** is displayed, click **Retry**. If it still fails, see **“Communication with the Card Slot failed.”** is displayed” on page 35.
- If **“Cannot map any more drives, because all the drive letters are assigned.”** is displayed, click **Skip** to complete the setup. After software installation is complete, remove any drive letter and try the network setup of the Card Slot again using the Canon IJ Network Tool.
- If **“The Card Slot is already mapped as Network Drive to this computer.”** is displayed, the Card Slot is already set up. Click **OK**, then click **Next**.

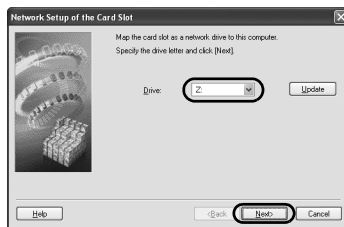

- 6** When the **Setup Completion** dialog box appears, remove the USB cable, then click **Finish**.

The network connection between the machine and the computer is now successfully established.

To confirm the setup results, click **View Setup Results**.

Note

- To change the port name, click **View Setup Results**, then click **Set Port Name** on the **Setup Results** dialog box. For details, see **“Changing the Port Name (Windows)”** on page 37.
- If **“Unsafe Removal of Device”** is displayed, click **OK**.

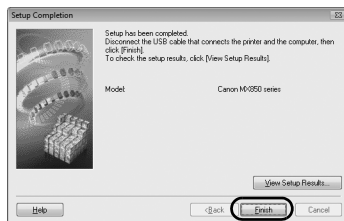

- 7** When the **Setup Complete** screen appears, click **Next**.



8 When the **User Registration** screen appears, click **Next**.

Note

- It is required to connect to the Internet to register your product. Turn on the firewall function before connecting your network to the Internet.
- To register later, click **Cancel** and go to step 9. After software installation is complete, double-click  on the desktop.
- If a message asking for your confirmation to restart your computer appears, follow the on-screen instructions to restart your computer.
- The **User Registration** screen may not be displayed depending on the country or region of purchase.

If your network is connected to the Internet, the registration screen will appear. Follow the on-screen instructions to register your product.

You will need your product serial number (A), which is located on the inside of the machine.

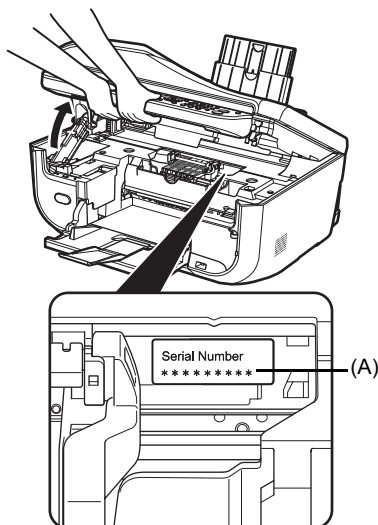

9 When the **PIXMA Extended Survey Program** screen appears, confirm the message.

We would appreciate it if you would take part in the PIXMA Extended Survey Program regarding the use of Canon printers. If you can agree, click **Agree**.

If **Do not agree** is clicked, the PIXMA Extended Survey Program will not be installed but you can use the machine normally.

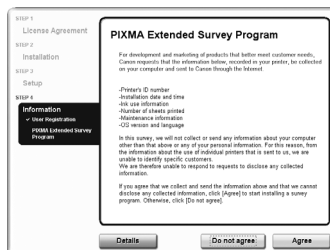

10 The Installation completed successfully screen appears.

If only one CD-ROM is included in the package for the Windows setup

Click **Exit**.

The *Setup CD-ROM* will be ejected.

If it is not ejected automatically, remove it manually.

If **Restart** is displayed, make sure that the **Restart the system now (recommended)** check box is selected, then click **Restart**. After the computer restarts, remove the *Setup CD-ROM*.

Note

Keep the CD-ROM in a safe place in case you need to reinstall the software.

If two CD-ROMs are included in the package for the Windows setup

When the **Continue to Windows CD-2** screen appears, perform the following steps (1) to (3) to complete the installation.

(1) Click **Exit**.

The *Setup CD-ROM* will be ejected.

If it is not ejected automatically, remove it manually.

If **Restart** is displayed, make sure that the **Restart the system now (recommended)** check box is selected, then click **Restart**. After the computer restarts, remove the *Setup CD-ROM*.

(2) Insert the *Setup CD-ROM* "Windows (CD-2) Macintosh".

(3) Follow the on-screen instructions to proceed with the setup.

After installation is complete, the *Setup CD-ROM* will be ejected.

If it is not ejected automatically, remove it manually.

Note

Keep the CD-ROMs in a safe place in case you need to reinstall the software.

When using Windows Vista:

To use the Card Slot over network, mount the Card Slot using the Canon IJ Network Tool after software installation is complete. For details, refer to "Using the Card Slot over a Network" in the *User's Guide* on-screen manual.



2-2 Setting Up an Additional LAN-connected Computer

(continued from step 9 on page 5)

Important

To set up an additional LAN-connected computer, the necessary software must be installed on the additional computer. See "1 Preparing for Setup" on page 2 and "2 Installing the Software" on page 3 to confirm that the software installation is complete, then proceed with the procedure below.

- 1 Make sure that the machine is connected to the network device with a LAN cable, then turn on the machine.

When you turn on the machine, the **COPY** button flashes green, then remains lit.

Note

- If MAC address filtering is configured to restrict access to the machine, make sure beforehand to register the address of the computer you are setting up. To register the address, use the Canon IJ Network Tool on the computer that has already been set up.
- Make sure that the computer you are setting up is not connected to the machine with a USB cable. This setup procedure does not involve connecting the USB cable.

- 2 On the **Setup Method** screen, select **Set up only the computer for network use**, then click **Next**.

The machine connected to the network is detected automatically.

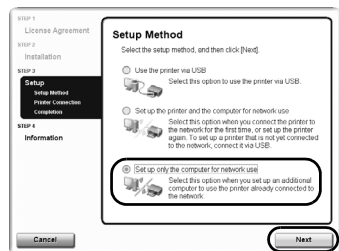

3 Select the machine on the **Printers** dialog box, then click **Next**.

In Windows Vista, go to step 5.

In Windows XP and Windows 2000, go to step 4.

Note

If the machine has not been detected, make sure of the following, then click **Update**.

- The machine is turned on and connected to the network device with the LAN cable.
- The machine is not set to use access control (MAC address filtering).
- The firewall function of any security software is turned off.
Some programs that switch the network environment depending on your system environment will enable a firewall function by default. Check the settings on any such software.

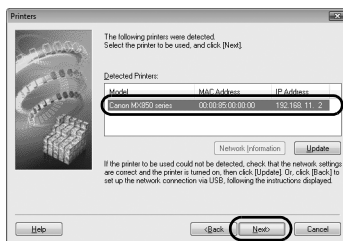

4 When the **Network Setup of the Card Slot** dialog box appears, specify the drive letter, then click **Next**.

This screen will not appear in Windows Vista.

Note

- The Card Slot of the machine must be mounted to be used as the memory card drive of the LAN-connected computer.
To write files to a memory card, set the **Read/write attribute** setting under **Device settings** to **LAN enabled**. If the setting is set to **USB enabled**, you cannot access the network drive of the Card Slot.
- If **“Communication with the Card Slot failed.”** is displayed, click **Retry**. If it still fails, see **““Communication with the Card Slot failed.”** is displayed”
- If **“Cannot map any more drives, because all the drive letters are assigned.”** is displayed, click **Skip** to complete the setup. After software installation is complete, remove any drive letter and try the network setup of the Card Slot again using the Canon IJ Network Tool.
- If **“The Card Slot is already mapped as Network Drive to this computer.”** is displayed, the Card Slot is already set up. Click **OK**, then click **Next**.

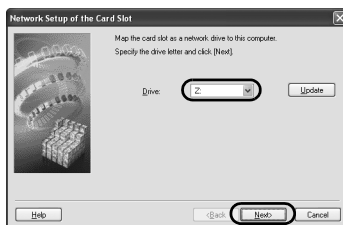

5 When the **Setup Completion** dialog box appears, click **Finish**.

The network connection between the machine and the computer is now successfully established.

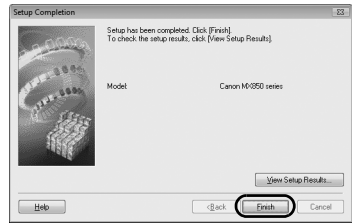

6 When the **Setup Complete** screen appears, click **Next**.



7 When the **User Registration** screen appears, click **Next**.

Note

- If you have already registered your product, click **Cancel**.
- It is required to connect to the Internet to register your product. Turn on the firewall function before connecting your network to the Internet.
- To register later, click **Cancel** and go to step 8. After software installation is complete, double-click  on the desktop.
- If a message asking for your confirmation to restart your computer appears, follow the on-screen instructions to restart your computer.
- The **User Registration** screen may not be displayed depending on the country or region of purchase.

If your network is connected to the Internet, the registration screen will appear. Follow the on-screen instructions to register your product.

You will need your product serial number (A), which is located on the inside of the machine.

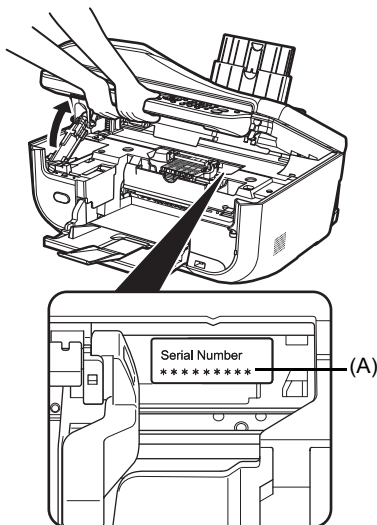

8 When the **PIXMA Extended Survey Program** screen appears, confirm the message.

We would appreciate it if you would take part in the PIXMA Extended Survey Program regarding the use of Canon printers. If you can agree, click **Agree**.

If **Do not agree** is clicked, the PIXMA Extended Survey Program will not be installed but you can use the machine normally.

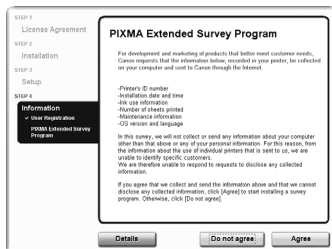

9 The Installation completed successfully screen appears.

If only one CD-ROM is included in the package for the Windows setup

Click **Exit**.

The *Setup CD-ROM* will be ejected.

If it is not ejected automatically, remove it manually.

If **Restart** is displayed, make sure that the **Restart the system now (recommended)** check box is selected, then click **Restart**. After the computer restarts, remove the *Setup CD-ROM*.



Note

Keep the CD-ROM in a safe place in case you need to reinstall the software.

If two CD-ROMs are included in the package for the Windows setup

When the **Continue to Windows CD-2** screen appears, perform the following steps (1) to (3) to complete the installation.

(1) Click **Exit**.

The *Setup CD-ROM* will be ejected.

If it is not ejected automatically, remove it manually.

If **Restart** is displayed, make sure that the **Restart the system now (recommended)** check box is selected, then click **Restart**. After the computer restarts, remove the *Setup CD-ROM*.

(2) Insert the *Setup CD-ROM* "Windows (CD-2) Macintosh".

(3) Follow the on-screen instructions to proceed with the setup.

After installation is complete, the *Setup CD-ROM* will be ejected.

If it is not ejected automatically, remove it manually.

Note

Keep the CD-ROMs in a safe place in case you need to reinstall the software.

When using Windows Vista:

To use the Card Slot over network, mount the Card Slot using the Canon IJ Network Tool after software installation is complete. For details, refer to "Using the Card Slot over a Network" in the *User's Guide* on-screen manual.

Setting Up the Machine and the Computer (Macintosh)

To use the machine connected to a computer, you need to install the software called “MP Drivers” in the computer.

The following two connection types are described in this manual.

Setting Up for Use over Wired LAN

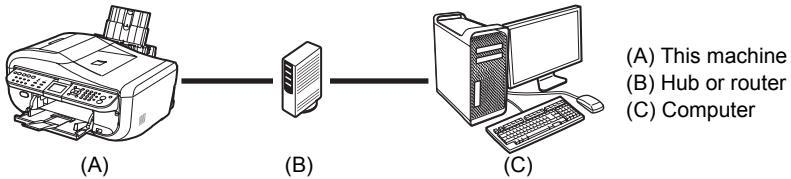

When the machine has not been connected to the network, perform this setup to use the machine over wired LAN. This setup procedure requires settings to be performed on the machine and the computer.

Note

- To set up the machine that is not yet connected to a wired LAN, connect the machine and the computer with a USB cable.
- Even if the machine has been set up to be used with the USB connection, follow the setup procedure described in this manual to connect the machine to a wired LAN for the first time.

Setting Up an Additional LAN-connected Computer

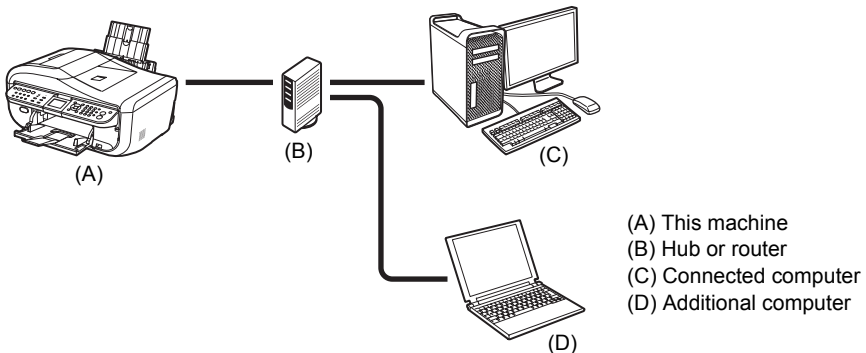

When the machine has already been set up to connect to the network, perform this setup to use the machine from an additional computer over wired LAN. This setup procedure only requires settings to be performed on the additional computer.

1 Preparing for Setup

Before installing the MP Drivers in your computer, make sure of the following.

- If the installation and adjustment of the machine have not been finished, refer to your setup sheet to set up the machine properly.
- Turn off the firewall function temporarily or change its setting. If you disable the firewall function, disconnect your network from the Internet.

For information on the firewall function of your security software, refer to its instruction manual or contact its manufacturer.

Important

After setup is complete, turn back on the firewall function you disabled for setup.

If you connect to a network that is not protected with security measures, there is a risk of disclosing data such as your personal information to a third party.

- Make sure that the configuration of computers, hubs, and other network devices is complete, and computers can connect to the network.

The configuration and the type of the device vary depending on your network environment. For details, refer to your device's instruction manual or contact its manufacturer.

Important

A hub and LAN cable are required to connect this machine to a wired LAN. These must be purchased separately.

Note

- In an office setup, consult your network administrator.
- Since Mac[®] OS 9, Mac OS X Classic environments, or Mac OS X v.10.3.8 or earlier are not supported, do not connect the machine to these.
- Log on as an Administrator.
- Quit all running applications before installation.

The screens in this manual refer to Mac OS X v.10.4.x installation. Screens may vary depending on the operation system you are using and also depending on the country or region of purchase.

2 Installing the Software

To set up an additional LAN-connected computer, you do not need to connect it to the machine with a USB cable. Start from step 2.

- 1 Connect the machine and the computer with a USB cable.

(A) USB port

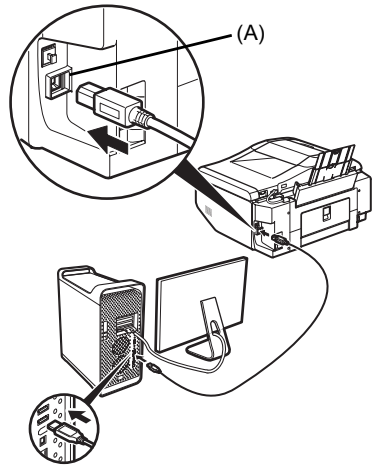

- 2 Turn on your Mac.

Note

Make sure that the machine is turned on.

- 3 Insert the *Setup CD-ROM*.

If the CD-ROM folder does not open automatically, double-click the CD-ROM icon  on the desktop.

Important

If two CD-ROMs are included in the package for the Windows setup, insert the *Setup CD-ROM "Windows (CD-2) Macintosh"* for the Macintosh setup.

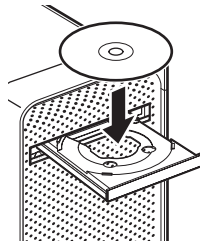

- 4 Double-click the **Setup** icon.



- 5 When the **Authenticate** screen appears, enter your administrator name and password, then click **OK**.

 **Note**

- If you do not know your administrator name or password, click  on the lower-left corner of the screen, then follow the on-screen instructions.
- If the **Select Language** screen appears, select a language, then click **Next**.
- If the **Select Your Place of Residence** screen appears, select your place of residence, then click **Next**.



- 6 When the screen shown on the right appears, click **Easy Install**.

The MP Drivers, On-screen Manuals, and application software are installed automatically.

 **Note**

If you want to select particular items to install, click **Custom Install** and follow the on-screen instructions to proceed with the installation.

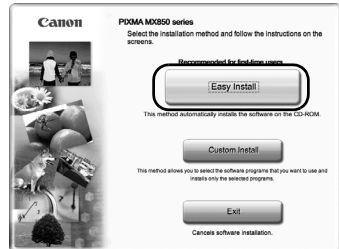

- 7 When the **Easy Install** screen appears, confirm the contents, then click **Install**.

 **Note**

- Move the cursor over items to display explanations of each application.
- The list of applications may vary depending on the country or region of purchase.

Users in Asia

- To view the *User's Guide* on-screen manual in a language other than the installed one, double-click the **Manual** folder in the *Setup CD-ROM*, **Canon** folder, and then copy a language folder to your hard disk.

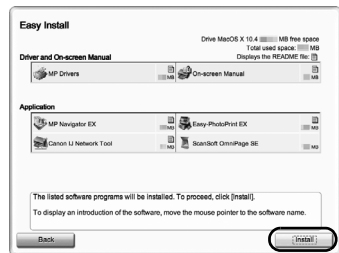

- 8 Read the License Agreement carefully and click **Yes**.

Installation of the MP Drivers, On-screen Manuals, and application software will begin.

The software installation screen may appear during the installation process. Read the contents on the screen and follow the on-screen instructions to install the software.

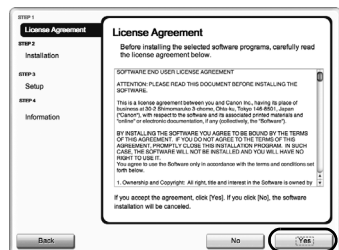

9 When the **Setup Complete** screen appears, click **Next**.

 **Note**

The **Setup Complete** screen may not be displayed depending on the country or region of purchase.

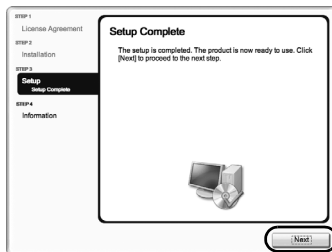

10 When the **User Registration** screen appears, click **Next**.

 **Note**

- It is required to connect to the Internet to register your product. Turn on the firewall function before connecting your network to the Internet.
- To register later, click **Cancel** and go to step 11.
- After software installation is complete, double-click  on the desktop.
- The **User Registration** screen may not be displayed depending on the country or region of purchase.



If your network is connected to the Internet, the registration screen will appear. Follow the on-screen instructions to register your product.

You will need your product serial number (A), which is located on the inside of the machine.

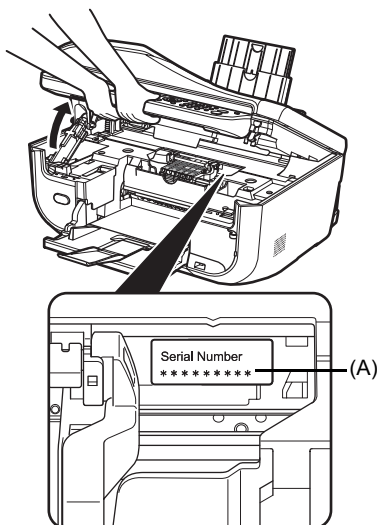

11 When the **Installation completed successfully** screen appears, click **Restart**.

The software installation is complete.

When the computer restarts, the Canon IJ Network Tool will start up automatically. Proceed with the network setup from following step 12.

After the computer restarts, remove the *Setup CD-ROM*.

Note

Keep the CD-ROM in a safe place in case you need to reinstall the software.

When using Mac OS X v.10.3.9:

Restarting the computer while connected to the machine may cause the machine not to be detected. To resolve this, either unplug the USB cable then plug it back in again, or turn the machine off then back on again.

Note

When using Mac OS X v.10.3.9, before using the Operation Panel on the machine to save scanned originals to the computer, it is necessary to select **MP Navigator EX** as the launch application on **Image Capture** under **Applications**. For details, refer to "Scanning Images" in the *User's Guide* on-screen manual.

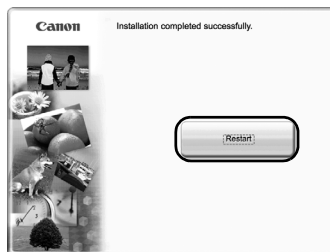

12 When the **Canon IJ Network Tool** screen appears, confirm the connection type.

The next procedure varies depending on how you intend to connect the machine and the computer.

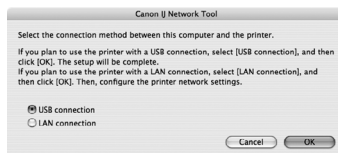

When you connect the machine to a computer for the first time

See "2-1 Setting Up for Use over Wired LAN" on page 23.

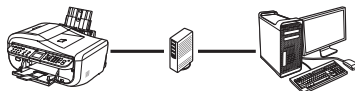

When the machine has not been connected to the network, perform this setup to use the machine over wired LAN. This setup procedure requires settings to be performed on the machine and the computer.

When you connect the machine to an additional computer

See "2-2 Setting Up an Additional LAN-connected Computer" on page 27.

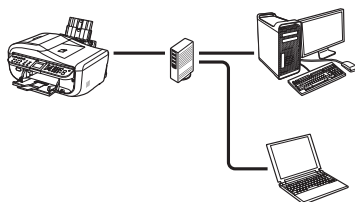

When the machine has already been set up to connect to the network, perform this setup to use the machine from an additional computer over wired LAN. This setup procedure only requires settings to be performed on the additional computer.

2-1 Setting Up for Use over Wired LAN

(continued from step 12 on page 22)

Important

When the machine has not been connected to the network, to set up the machine to be used from a LAN-connected computer, the necessary software must be installed on the computer. See “1 Preparing for Setup” on page 17 and “2 Installing the Software” on page 18 to confirm that the software installation is complete, then proceed with the procedure below.

1 On the **Canon IJ Network Tool** screen, select **LAN connection**, then click **OK**.

If the Canon IJ Network Tool does not start up automatically, select **Library > Printers > Canon > BJPrinter > Utilities > Canon IJ Network Tool**.

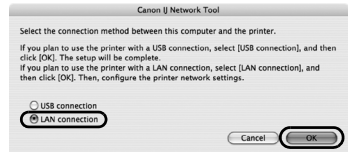

Note

If you select **USB connection**, the Canon IJ Network Tool will exit without setting up the machine to be used over wired LAN.

If the screen shown on the right appears, make sure of the following, then click **OK**.

- The machine is turned on.
- The machine is connected to the computer with a USB cable.
- The MP Drivers have been installed.



2 Select **Setup** in the pop-up menu, select your machine’s name in **Printers**, then click **OK**.

Note

- If no printer is detected, click **OK**. Make sure of the following, then click **Update**.
 - The machine is connected to the computer with a USB cable.
 - The machine is turned on.
- If the machine’s network settings are already configured, the **Setup Environment Confirmation** dialog box appears asking for your confirmation to use the machine with the current settings. You can proceed with the setup using the current network settings. To do so, click **Use as is**. To reconfigure the network settings, click **Reconfigure**.

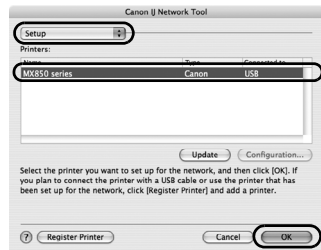

3 When the **Check Wired LAN Connection** dialog box appears, remove the LAN connector cap, connect the machine to the network devices such as hubs with a LAN cable, then click **Yes**.

- (A) Wired LAN connector
- (B) LAN connector cap

Note

The connection may vary depending on your network environment.

The machine connected with the USB cable is detected automatically via LAN connection.

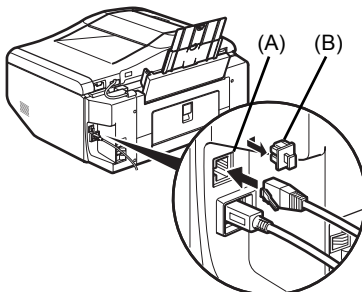

Note

If the machine was not detected, the **Set Printer IP Address** dialog box appears. Make sure of the following, then click **Connect**.

- The network devices such as hubs or routers are turned on, and the machine and the computer are connected to the network.
- The machine is connected to the computer with the USB cable.
- The IP address to be set for the machine is displayed on the **Set Printer IP Address** dialog box.

If it is different from the address you want to set for the machine, select **Use following IP address** in **TCP/IP Setting** and enter the desired IP address. (If the machine is turned off, the **Set Printer IP Address** dialog box does not appear.)

If it still fails, see "The Set Printer IP Address dialog box is displayed" on page 33.

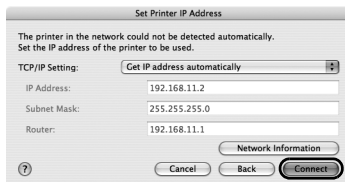

4 When the **Setup Completion** dialog box appears, remove the USB cable, then click **OK**.

The network connection between the machine and the computer is now successfully established.

The Printer Setup Utility and Canon IJ Network Scanner Selector will start up.

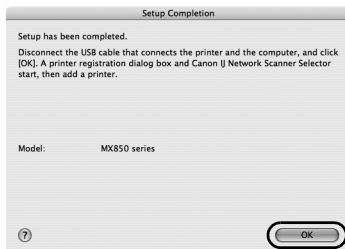

5 On the **Printer List** dialog box, click **Add**.

In Mac OS X v.10.4.x, go to step 6.

In Mac OS X v.10.3.9, go to step 7.

Note

The machine displayed in the list is the one connected with the USB cable. You need to add the machine connected to the network to the list.

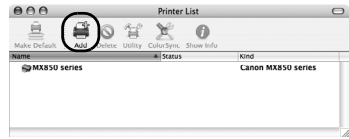

6 On the **Printer Browser** dialog box, click **More Printers**.

This screen will not appear in Mac OS X 10.3.9.



7 Select **Canon IJ Network** in the pop-up menu, select your machine's name in the list of printers, then click **Add**.

Note

The alphanumeric string after the machine's name is its MAC address.

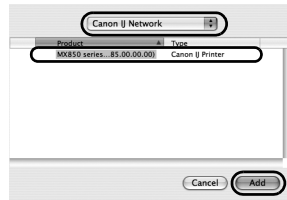

8 Confirm that your machine's name is added to the list of printers.

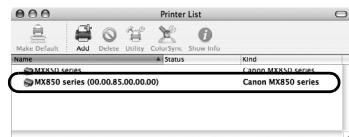

9 On the **Canon IJ Network Scanner Selector** screen, select **Canon XXX Network** (where “**XXX**” is your machine’s name) in **TWAIN Data Source Name** and the MAC address of the machine in **Network Device List**, then click **Apply** to use the machine as a scanner.

Confirm that a check mark is displayed, then click **Exit** to close the dialog box.

The setup of the machine and the computer is complete.

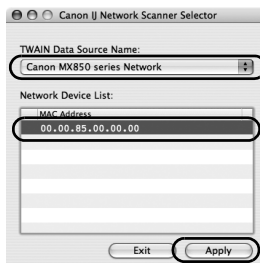

Note

- To confirm the machine’s MAC address, display the machine’s network setting information. See “Checking Information about the Network” on page 38.
- For details on how to scan, refer to the *User’s Guide* and *Scanning Guide* on-screen manuals.

After the installation is complete, start up the Canon IJ Network Tool to mount the Card Slot. For details on the network setup of the Card Slot, refer to “Using the Card Slot over a Network” in the *User’s Guide* on-screen manual.

2-2 Setting Up an Additional LAN-connected Computer

(continued from step 12 on page 22)

Important

To set up an additional LAN-connected computer, the necessary software must be installed on the additional computer. See "1 Preparing for Setup" on page 17 and "2 Installing the Software" on page 18 to confirm that the software installation is complete, then proceed with the procedure below.

- 1 Make sure that the machine is connected to the network device with a LAN cable.

Note

- If MAC address filtering is configured to restrict access to the machine, make sure beforehand to register the address of the computer you are setting up. To register the address, use the Canon IJ Network Tool on the computer that has already been set up.
- Make sure that the computer you are setting up is not connected to the machine with a USB cable. This setup procedure does not involve connecting the USB cable.

- 2 On the **Canon IJ Network Tool** screen, select **LAN connection**, then click **OK**.

If the Canon IJ Network Tool does not start up automatically, select **Library > Printers > Canon > BJPrinter > Utilities > Canon IJ Network Tool**.

Note

If you select **USB connection**, the Canon IJ Network Tool will exit without setting up the machine to be used over wired LAN.

- 3 When the screen shown on the right appears, click **OK**.

- 4 Select **Setup** in the pop-up menu, then click **Register Printer**.

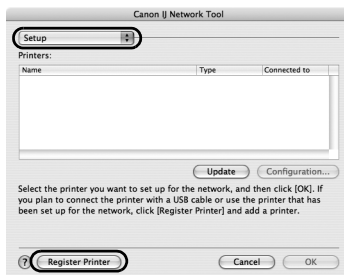
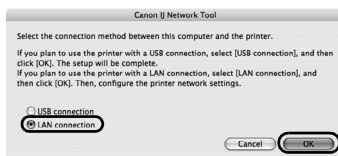

5 When the **Cancel Setup** screen appears, click **Cancel**.

The Printer Setup Utility and Canon IJ Network Scanner Selector will start up.

If “**You have no printers available.**” is displayed, click **Cancel**.



6 On the **Printer List** dialog box, click **Add**.

In Mac OS X v.10.4.x, go to step 7.

In Mac OS X v.10.3.9, go to step 8.



7 On the **Printer Browser** dialog box, click **More Printers**.

This screen will not appear in Mac OS X 10.3.9.



8 Select **Canon IJ Network** in the pop-up menu, select your machine's name in the list of printers, then click **Add**.

Note

- The alphanumeric string after the machine's name is its MAC address.
- If the machine has not been detected, make sure of the following.
 - The machine is turned on and connected to the network device with the LAN cable.
 - The machine is not set to use access control (MAC address filtering).
 - The firewall function of any security software is turned off.

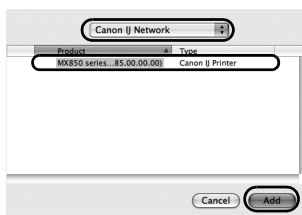

9 Confirm that your machine's name is added to the list of printers.



10 On the **Canon IJ Network Scanner Selector** screen, select **Canon XXX Network** (where “**XXX**” is your machine’s name) in **TWAIN Data Source Name** and the MAC address of the machine in **Network Device List**, then click **Apply** to use the machine as a scanner.

Confirm that a check mark is displayed, then click **Exit** to close the dialog box.

The setup of the machine and the computer is complete.

 **Note**

- To confirm the machine’s MAC address, display the machine’s network setting information. See “Checking Information about the Network” on page 38.
- For details on how to scan, refer to the *User’s Guide* and *Scanning Guide* on-screen manuals.

After the installation is complete, start up the Canon IJ Network Tool to mount the Card Slot. For details on the network setup of the Card Slot, refer to “Using the Card Slot over a Network” in the *User’s Guide* on-screen manual.

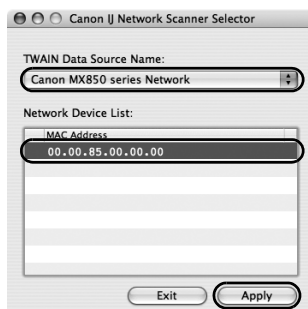



Troubleshooting

This section describes troubleshooting tips for problems you may encounter when setting up.

Note

If you do not find a description for your trouble here, refer to “Troubleshooting” in the *User’s Guide* on-screen manual.

Troubles in setup/connections

- “Cannot Install the MP Drivers” on page 31
- “Cannot Connect to the Machine (the machine is not detected)” on page 32
- “The Following Screen Is Displayed during Setup” on page 33
 - “The Set Printer IP Address dialog box is displayed” on page 33
 - “The Enter Password dialog box is displayed” on page 34
 - ““Communication with the Card Slot failed.” is displayed” on page 35
 -  ““The Card Slot is already mapped as Network Drive to this computer.” is displayed” on page 36
 -  ““Cannot map any more drives, because all the drive letters are assigned.” is displayed” on page 36



Other troubles



Refer to “Troubleshooting” in the *User’s Guide* on-screen manual.

Other useful information

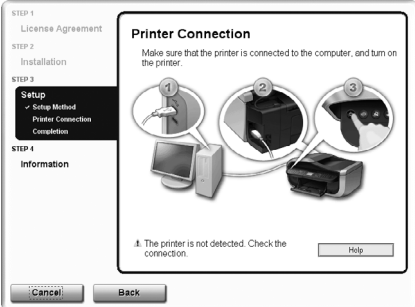
- “Setting Up the Machine Again for Use over Network” on page 37
- “Changing the Port Name (Windows)” on page 37
- “Checking Information about the Network” on page 38

Cannot Install the MP Drivers

Cause	Action
<p>Windows</p> <p>Unable to proceed beyond the Printer Connection screen.</p>	<p>If you were unable to proceed beyond the Printer Connection screen, make sure that the USB cable is securely plugged into the USB port of the machine and is connected to the computer, and then follow the procedure below to reinstall the MP Drivers.</p> <p>In Windows Vista, "The printer is not detected. Check the connection." may be displayed depending on the computer you use. In this case, wait for a while. If you still cannot proceed to the next step, follow the procedure below to reinstall the MP Drivers.</p>  <ol style="list-style-type: none"> (1) Click Cancel on the Printer Connection screen. (2) Click Start Over on the Installation Failure screen. (3) Click Back on the screen that appears next. (4) Click Exit, then remove the CD-ROM. (5) Turn the machine off. (6) Restart the computer. (7) Make sure you have no application software running. (8) Follow the procedure described in "Setting Up the Machine and the Computer (Windows)" on page 1 to reinstall the MP Drivers.
<p>Installation does not start automatically when the <i>Setup CD-ROM</i> is inserted into your computer's disc drive.</p>	<p>Windows</p> <ol style="list-style-type: none"> (1) Click Start then Computer. In Windows XP, click Start then My Computer. In Windows 2000, double-click the My Computer icon on the desktop. (2) Double-click the CD-ROM icon  on the displayed window. If the contents of the CD-ROM are displayed, double-click MSETUP4.EXE. <p>Macintosh</p> <ol style="list-style-type: none"> (1) Double-click the CD-ROM icon  displayed on your desktop to start installation. <p>Note</p> <p>If the CD-ROM icon is not displayed, perform the following.</p> <ul style="list-style-type: none"> – Remove the CD-ROM from your computer, then insert it again. – Restart your computer. <p>If the icon is still not displayed, try different discs and see if they are displayed. If other discs are displayed, there is a problem with the <i>Setup CD-ROM</i>. Contact your Canon service representative.</p>

Cause	Action
<p>Installation procedure not followed correctly.</p>	<p>Follow the procedure described in “Setting Up the Machine and the Computer (Windows)” on page 1 or “Setting Up the Machine and the Computer (Macintosh)” on page 16 for proper installation.</p> <p>If the MP Drivers were not installed correctly, uninstall the MP Drivers, restart your computer, and then reinstall the MP Drivers. Refer to the <i>PC Printing Guide</i> on-screen manual.</p> <p> Windows</p> <p> Note</p> <p>If the installer was forced to be terminated due to a Windows error, the system may be in an unstable condition and you may not be able to install the MP Drivers. Restart your computer before reinstalling.</p>

Cannot Connect to the Machine (the machine is not detected)

Cause	Action
<p>The machine is not detected</p>	<ul style="list-style-type: none"> ● Make sure that the machine is turned on. ● Firewall function provided by security software may prevent proper setup or communication over a network. When setting up the machine to be used over a network, disable any firewall function provided by security software during the setup.
<p>The machine is not detected after the network settings are changed</p>	<ul style="list-style-type: none"> ● Wait until the IP address is assigned to the computer. Search for the machine again after confirming a valid IP address is assigned to the computer. ● The IP version may be set to IPv6. If the IP version of the machine is set to IPv6, change it to IPv4. For details, refer to “LAN Settings” in “Device Settings” in “Changing the Machine Settings” of the <i>User’s Guide</i> on-screen manual.

The Following Screen Is Displayed during Setup

■ The Set Printer IP Address dialog box is displayed

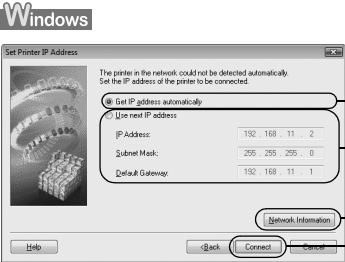
Cause	Action
<p>The machine in the network was not detected.</p>	<p>Specify the IP address of the machine and click Connect to retry the detection of the machine.</p>  <p>The IP address currently set for the machine is displayed on the dialog box.</p> <p>(1) Get IP address automatically Select to use an IP address provided by a DHCP server. This requires that the DHCP function is enabled on the router.</p> <p>(2) Use next IP address Select to manually specify an IP address, for example if there is no DHCP server functionality in the network environment in which you are using the machine.</p> <p>IP Address/Subnet Mask/Default Gateway Enter each value to specify a fixed IP address when Use next IP Address is selected.</p> <p>(3) Network Information Click to display the Network Information dialog box, and confirm network settings when your machine cannot be detected automatically during setup for use over the network.</p> <p>(4) Connect Click to search for the machine with the specified settings. If the machine is still not detected with a specified IP address, see "Cannot Connect to the Machine (the machine is not detected)" on page 32.</p>

Cause	Action
<p>The machine in the network was not detected. (Continued)</p>	<div data-bbox="412 140 896 363"> </div> <p>The IP address currently set for the machine is displayed on the dialog box.</p> <p>(1) TCP/IP Setting Select Get IP address automatically or Use following IP address. Select Get IP address automatically to use an IP address provided by a DHCP server. This requires that the DHCP function is enabled on the router. Select Use following IP address to manually specify an IP address, for example if there is no DHCP server functionality in the network environment in which you are using the machine. IP Address/Subnet Mask/Router Enter each value to specify a fixed IP address when Use following IP address is selected.</p> <p>(2) Network Information Click to display the Network Information dialog box, and confirm network settings when your machine cannot be detected automatically during setup for use over the network.</p> <p>(3) Connect Click to search for the machine with the specified settings. If the machine is still not detected with a specified IP address, see "Cannot Connect to the Machine (the machine is not detected)" on page 32.</p>

■ The Enter Password dialog box is displayed

Cause	Action
<p>The administrator password is set to the machine that has already been set up.</p>	<div data-bbox="412 922 1008 1109"> </div> <p>Enter the administrator password you have set.</p> <p>Admin Password The administrator password consists of alphanumeric characters and is no longer than 32 characters. The password is case sensitive. For security, your entry will be displayed by "*" or "+" (bullets).</p>

■ “Communication with the Card Slot failed.” is displayed

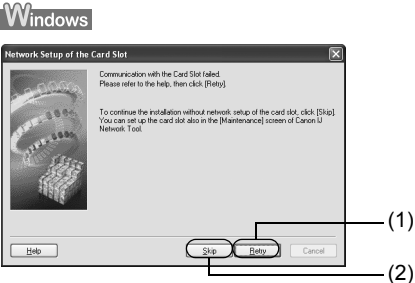
Cause	Action
<p>The network setup of the Card Slot fails.</p>	<p>Wait for a while, then click Retry.</p>  <p>(1) Retry Click to retry the network setup of the Card Slot.</p> <p>(2) Skip Click to continue installation without the network setup of the Card Slot.</p> <p>If it fails again after clicking Retry, follow the procedure below.</p> <ul style="list-style-type: none"> ● Make sure that the computer is communicating with the network properly, then try again. ● Disable the Windows Firewall function, or open port 137:139 to allow communication with the machine following the procedure below. For information on other security software, refer to its instruction manual or contact its manufacturer. <p>Important</p> <p>If you disabled the firewall function, disconnect your network from the Internet. To do this, configure your router not to connect to the Internet or WAN.</p> <p>To disable the Windows Firewall:</p> <ol style="list-style-type: none"> (1) Click Start > Control Panel > Security Center > Windows Firewall. (2) Select Off, and click OK. <p>To open port 137:139:</p> <ol style="list-style-type: none"> (1) Click Start > Control Panel > Security Center > Windows Firewall. (2) Select the Exceptions tab, and click Add port. (3) On the Add a Port dialog box, input the following information, and click OK. <ul style="list-style-type: none"> Name: Input any name for the port. Port number: Input “137”. TCP/UDP: Select TCP. (4) Repeat steps (2) and (3). On the Add a Port dialog box, input the same information as you did in step (3) except for selecting UDP in TCP/UDP. (5) Use the same procedure to open the other ports (138TCP, 138UDP, 139TCP, and 139UDP). (6) Confirm that the port names are added on the Exceptions sheet, and click OK.

Cause	Action
<p>The network setup of the Card Slot fails. (Continued)</p>	<ul style="list-style-type: none"> ● Change the workgroup name to "WORKGROUP" following the procedure below. <ol style="list-style-type: none"> (1) Right-click My Computer, then select Properties. (2) Select the Computer Name tab, then click Change. (3) Change the workgroup name to "WORKGROUP", then click OK. <p>If the problem is not resolved, click Skip to complete the installation without the network setup of the Card Slot. After installation is complete, to mount the Card Slot using the Canon IJ Network Tool, refer to "Using the Card Slot over a Network" in the <i>User's Guide</i> on-screen manual. To mount the Card Slot manually, refer to "Cannot Mount the Card Slot" in "Troubles When Using the Machine over Network" in "Troubleshooting" of the <i>User's Guide</i> on-screen manual.</p> <p>Macintosh</p> <ul style="list-style-type: none"> ● Make sure that a memory card is inserted in the Card Slot. If it is not inserted, insert it. <p> Note</p> <p>Depending on the Mac OS version, the authentication screen may appear. If it appears, click OK.</p> <p>If the problem is not resolved, click Skip to complete the setup without the network setup of the Card Slot. To mount the Card Slot manually, refer to "Cannot Mount the Card Slot" in "Troubles When Using the Machine over Network" in "Troubleshooting" of the <i>User's Guide</i> on-screen manual.</p>

Windows

- "The Card Slot is already mapped as Network Drive to this computer." is displayed

Cause	Action
<p>The Card Slot has already been mapped as the network drive.</p>	<p>The Card Slot is already available. Click OK to close the dialog, then click Next on the Network Setup of the Card Slot dialog box.</p>

Windows

- "Cannot map any more drives, because all the drive letters are assigned." is displayed

Cause	Action
<p>All drive letters are assigned.</p>	<p>Click Skip to complete the setup. After software installation is complete, remove any drive letter and try the network setup of the Card Slot again using the Canon IJ Network Tool. For details, refer to "Using the Card Slot over a Network" in the <i>User's Guide</i> on-screen manual.</p>

Setting Up the Machine Again for Use over Network

Restore the machine settings to the default and set up the machine to be used over network.

For details on restoring the machine settings to the default, refer to “Initializing Network Settings” in “Displaying and Initializing Network Settings” of the *User’s Guide* on-screen manual.

For details on setting up the machine again, see “2 Installing the Software” on page 3 for Windows or “2 Installing the Software” on page 18 for Macintosh. Click **Custom Install** in step 6, then select **MP Drivers** and **Canon IJ Network Tool** to install. If you have downloaded the latest MP Drivers from our website and installed them on your computer, select **Canon IJ Network Tool** only to install.

Changing the Port Name (Windows)

To change the port name, click **View Setup Results** on the **Setup Completion** dialog box, then click **Set Port Name**.

The **Set Port Name** dialog box is displayed, where you specify the port name. By changing the port name, you can change the name of the machine. When you set up an additional computer to use the machine whose port name you changed, the machine is displayed with the changed port name.

When multiple computers or printers are present, it is useful to change the name to one that is easy to remember.

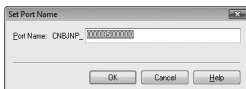

Port Name

Port names should consist of alphanumeric characters and be no longer than 21 characters, excluding the prefix. The port name includes the fixed prefix “CNBJNP_”, which you do not need to enter.

Checking Information about the Network

■ Checking the IP address or the MAC address of the machine

To check the IP address or the MAC address of the machine, display the network setting information using the Operation Panel of the machine or the Canon IJ Network Tool.

To display the network setting information using the Operation Panel, refer to “Displaying Network Setting Information” in “Displaying and Initializing Network Settings” of the *User’s Guide* on-screen manual.

To display the network setting information using the Canon IJ Network Tool, select **Network Information** on the **View** menu.

■ Checking the IP address or the MAC address of the computer

To check the IP address or MAC address assigned to the computer, follow the procedure below.

Windows

- (1) Click **Start > All Programs** (or **Programs**) > **Accessories > Command Prompt**.
- (2) Enter “ipconfig /all” and press the **Enter** key.
The IP addresses and the MAC addresses of the network devices installed on your computer are displayed. When the network device is not connected to the network, the IP address is not displayed.

Macintosh

- (1) Click **System Preferences** in the Dock, then click **Network**.
- (2) In the **Show** pop-up menu, select **Built-in Ethernet**.
Selecting **TCP/IP** displays the IP address. Selecting **Ethernet** displays the MAC address.

■ Checking the network setting information

For details on displaying the network setting information, refer to “Displaying Network Setting Information” in “Displaying and Initializing Network Settings” of the *User’s Guide* on-screen manual.

Windows

■ Confirming the version of Windows XP

If you are using Windows XP, you may need to confirm your system version to configure the network setting of your computer.

To check the version of your Windows XP, follow the procedure below.

- (1) Right-click **My Computer** on the **Start** menu and select **Properties**.
The **System Properties** dialog box will be displayed.
- (2) Select the **General** tab.
- (3) Confirm the version of your Windows XP under **System**.

The following ink tanks are compatible with this product.



For information on product specifications, please visit our website at

www.canon-asia.com

canon.com.au

www.canon.ca

canon.co.nz

www.usa.canon.com