

Canon

CanoScan LiDE 20/LiDE 30

English

Quick Start Guide

Be sure to install the software programs before connecting the scanner to the computer!

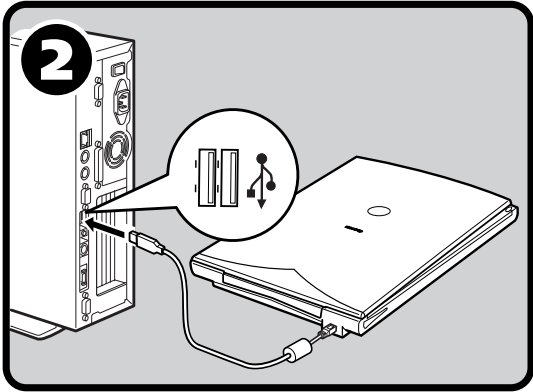
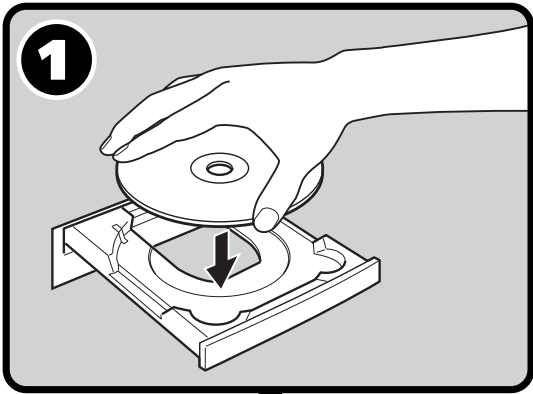

Setup and Scanning

- Check the Package Contents p.3
- ↓
- 1 Install the Software
 - Windows p.4
 - Macintosh p.5
- ↓
- Unlock the Scanning Unit p.6
- ↓
- 2 Connect the Scanner p.7
- ↓
- Try Scanning p.8

Try the Additional Features

- Using the Scanner Buttons p.11
- Using the Scanner in the Upright Position p.12

Guide to the Manuals

Open the Package

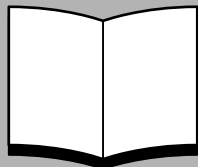

Quick Start Guide (this guide)

This guide describes a series of processes, from opening the package to using the scanner.

READ THIS GUIDE FIRST!



HTML

Scanning Guide (HTML format manual)

Refer to this guide when you have finished setting up the scanner according to the procedures in the Quick Start Guide. It describes how to utilize the scanner with the bundled software, and how to solve problems when they occur. You can install this manual onto the hard disk together with the software programs. When you install it, the Scanning Guide icon will appear on the desktop. Double-click the icon to view it with a browser program, such as Internet Explorer.



PDF

User's Guides for Application Programs (PDF format manuals)

- ArcSoft PhotoStudio
- ArcSoft PhotoBase
- OmniPage SE

Select the "View the Electronic Manuals" menu on the CanoScan Setup Utility CD-ROM. To read these manuals, Adobe Acrobat Reader should be installed on your computer.

Use of a shielded cable with the ferrite core(s) provided with the scanner is necessary to comply with the technical requirements of the EMC Directive.

Warning

When you use this product, you should pay attention to the following legal issues:

- Scanning of certain documents, such as bank notes (bank bills), government bonds and public certificates, may be prohibited by law and may result in criminal and/or civil liability.
- You may be required under law to obtain authorization from a person possessing copyrights or other legal rights to the item being scanned.

If you are uncertain of the legality of scanning any particular item, you should consult your legal adviser in advance.

- CanoScan and ScanGear are trademarks of Canon Inc.
- Adobe® and Acrobat® are trademarks of Adobe Systems Incorporated.
- Microsoft and Windows are registered trademarks of Microsoft Corporation in the U.S. and other countries.
- Macintosh, Power Macintosh and Mac OS are trademarks of Apple Computer, Inc., registered in the U.S. and other countries.
- ScanSoft and OmniPage are trademarks of ScanSoft, Inc.
- Other names and products not mentioned above may be trademarks or registered trademarks of their respective companies.

In this guide the screen shots are taken with Windows XP in the explanation common to all operating systems.

Check the Package Contents

Scanner and Accessories

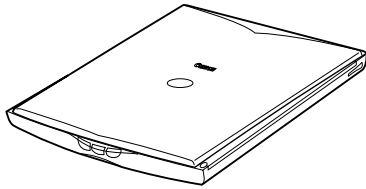

Scanner

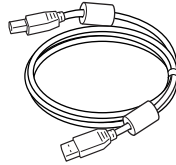

USB Interface Cable

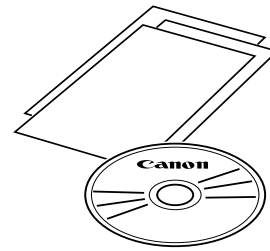
Stand
Page 12

Documents and Software Programs

- Quick Start Guide (this guide)
- Additional documents
- CanoScan Setup Utility CD-ROM

ScanGear CS (25 MB / 5 MB) - Scanner Driver

It allows you to scan and load images from the scanner.

CanoScan Toolbox (5 MB / 3 MB) - Scanning Utility Program

It enables you to scan images and copy (print), attach images to e-mail messages or save images with simple steps. It also works with the scanner buttons.

ArcSoft PhotoStudio (30 MB / 19 MB) - Image Editing Program

It allows you to load images from the scanner, edit and retouch them, and apply special effects and enhancements.

ArcSoft PhotoBase (75 MB / 5 MB) - Photo Album Program

It allows you to create and edit image albums, perform image searches and create slide shows.

ScanSoft OmniPage SE (65 MB / 48 MB) - OCR (Optical Character Recognition) Program

It converts characters scanned from a book, magazine or newspaper into text data for editing or digital transmission.

Adobe Acrobat Reader (24 MB / 24 MB) - Electronic Manual Viewer Program (PDF manual)

Electronic manuals for the above software programs (HTML (5 MB) and PDF manuals)



- The two figures in the brackets above indicate the respective sizes of the Windows/ Macintosh versions of the software.
- Approximately 229 MB (for Windows) / 109 MB (for Macintosh) of hard disk space on your computer is required to install all the programs. Additional free hard disk space is required to operate the programs.

Windows

Install the Software (Windows)



- With Windows XP/2000, you should log on with an administrator user name when you install or uninstall software programs.

1 Turn the computer on.

If the "Found New Hardware Wizard" or "Add New Hardware Wizard" appears, click [Cancel].

2 Place the CanoScan Setup Utility CD-ROM in the drive. After you select your language, the CanoScan Setup Utility main menu will display.

3 Click [Install the Software]. Read the SOFTWARE USER LICENSE AGREEMENT. Click [Yes] if you accept the terms.

The [Install] window will display.

4 Click [Start Installation]. You will install six software programs and the Scanning Guide (HTML format manual).

5 The installation procedure will start. Follow the on-screen message prompts and click [Yes] or [Next] to continue the installation.

6 When the installation is complete, click [Yes]. The computer will restart.

7 After Windows restarts, remove the CD-ROM from the drive and store it in a safe place.

➔ Continue on P. 6.

4

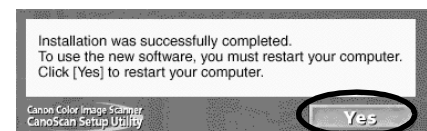
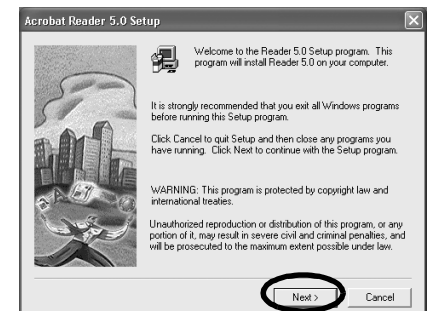
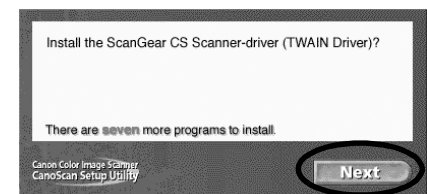
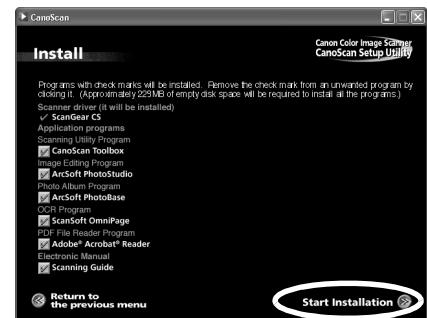

Install the Software (Macintosh)

- 1** Turn the computer on.

If the "...Would you like to look for the software on the Internet?" appears, click [Cancel].

- 2** Place the CanoScan Setup Utility CD-ROM in the drive.

After you select your language, the CanoScan Setup Utility main menu will display.

If no window displays, double-click the CD-ROM icon, then the Setup icon.

- 3** Click [Install the Software].
Read the SOFTWARE USER LICENSE AGREEMENT. Click [Yes] if you accept the terms.

The [Install] window will display.

- 4** Click [Start Installation].
You will install six software programs and the Scanning Guide (HTML format manual).

- 5** The installation procedure will start.
Follow the on-screen message prompts and click [Yes], [Next] or [Install] to continue the installation.

- 6** When the installation is complete, click [Yes].
The computer will restart.

- 7** After restarting, remove the CD-ROM from the drive and store it in a safe place.

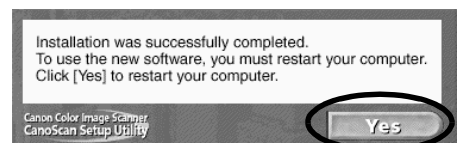
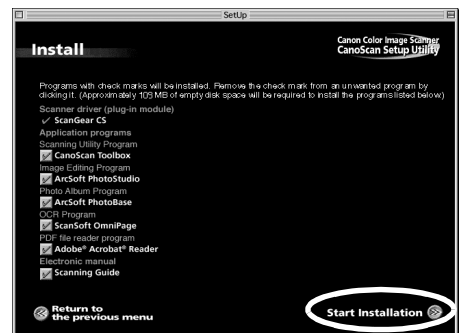

Unlock the Scanning Unit



• Unlock the Scanning Unit before connecting the scanner to the computer. If it is left locked, a malfunction or other problem may occur.

- 1** Peel the caution seal on the front of the scanner.
- 2** Gently turn the scanner over.

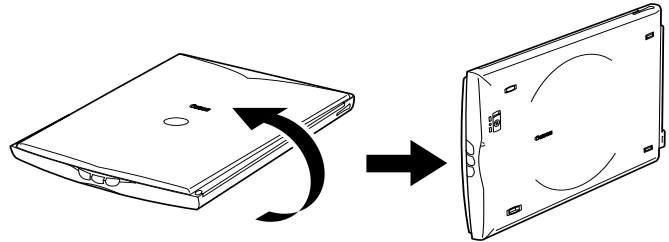

- 3** Push the lock switch toward the unlock mark (🔓).

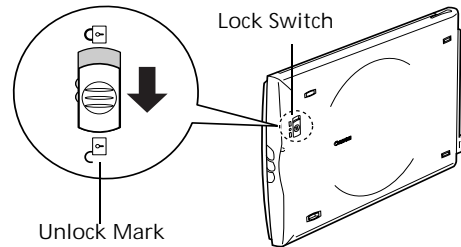

- 4** Return the scanner to a horizontal position.



• When transporting the scanner, always lock the scanning unit by pushing the lock switch toward the lock mark (🔒).
• Carrying or transporting the scanner without locking the scanning unit may damage it. Be particularly careful to lock the scanning unit when transporting the scanner in a vehicle.

Connect the Scanner

- Confirm that the Scanning Unit is unlocked. (P.6)

- 1 Peel the caution seal on the back of the scanner.
- 2 Connect the scanner to the computer with the supplied USB interface cable.

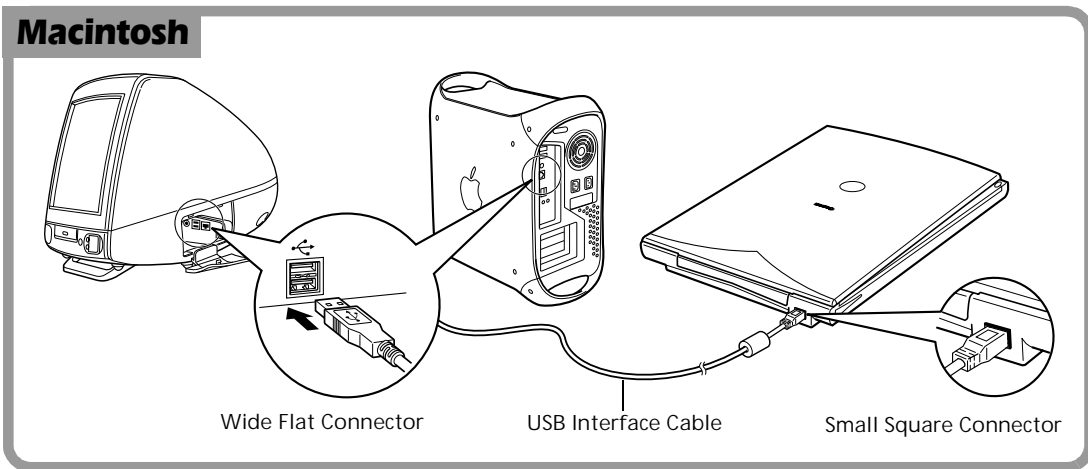
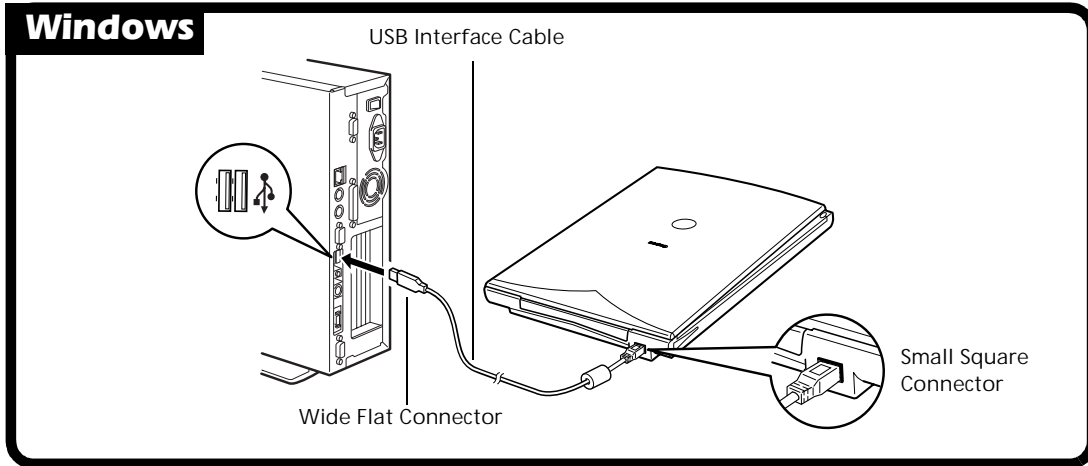

- Only use the USB interface cable provided with the scanner. Use of other cables may lead to a malfunction.
- The scanner does not have a power switch. The power is activated as soon as the computer is turned on.

Try Scanning

The following steps explain how to scan with ArcSoft PhotoStudio.

- 1 Place a photo or a picture on the glass by aligning its top edge with the alignment mark, and close the document cover.

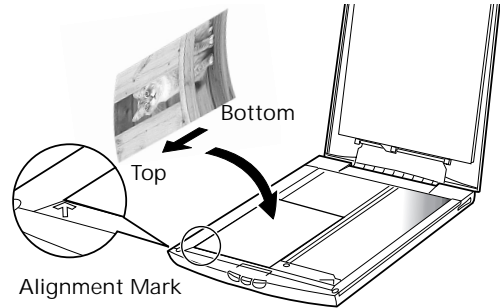

Windows

- 2 Select [Start], [Programs] or [All Programs], [ArcSoft PhotoStudio] and [PhotoStudio 5].

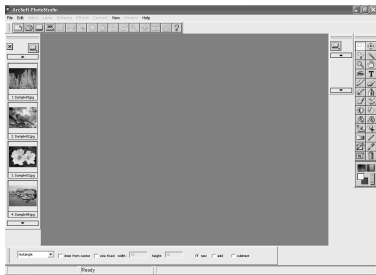
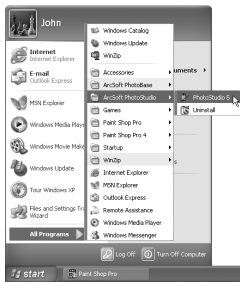

PhotoStudio will start.

- 3 Select this scanner.
 - a. Click the [File] menu and select [Select Source].
 - b. Highlight the scanner name and click [OK].



This step is required only for the first time.

Macintosh

- 2 Double-click the [Applications (Mac OS 9)] folder and [PhotoStudio] folders and the [PhotoStudio] icon.

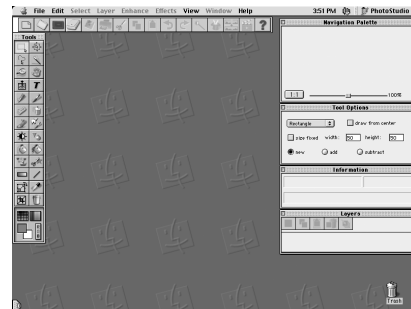

PhotoStudio will start.

- 3 Select this scanner.
 - a. Click the [File] menu and select [Select Source].
 - b. Highlight the driver name and click [OK].

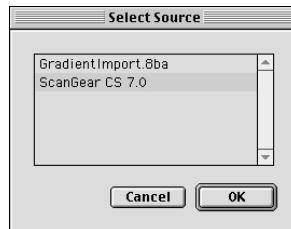

This step is required only for the first time.

Try Scanning

English

Windows

- 4** Click the Acquire icon  or click the [File] menu and select [Acquire].



ScanGear CS will start.

Macintosh

- 4** Click the Acquire icon  or click the [File] menu and select [Import..].

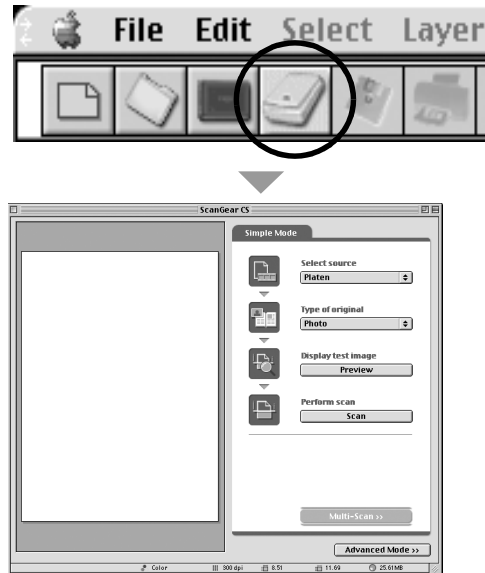

ScanGear CS will start.

- 5** Select "Type of original".
You can select "Photo", "Magazine", "Newspaper" or "Document".

- Photo: Color, 300 dpi
- Magazine: Color, 150 dpi
- Newspaper: Black and White, 300 dpi
- Document: Grayscale, 300 dpi

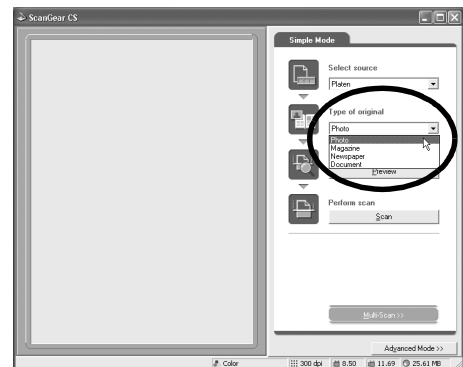

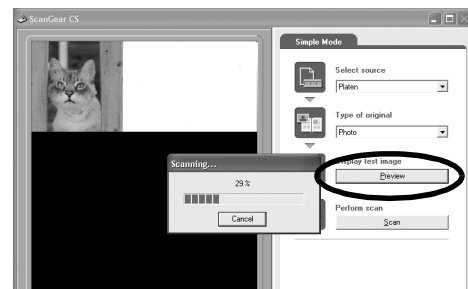

- 6** Click [Preview].
After calibration, the preview scan will start and gradually display the image.
The image is automatically cropped in the original size.
If you want to trim the image further, drag the mouse diagonally to select the area.



Try Scanning

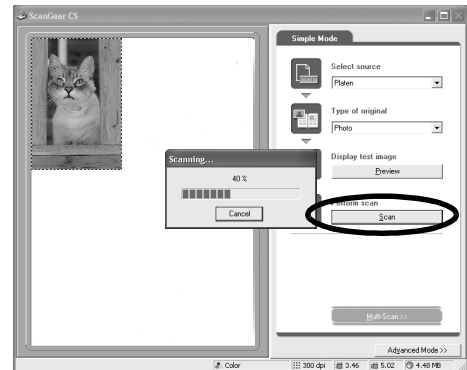

- 7** Click [Scan].
The final scan will start.

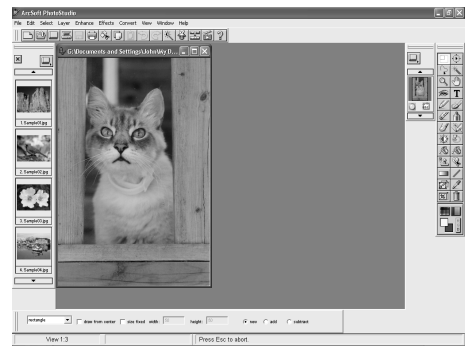

- 8** Click  or  (close box) in the ScanGear CS window to close it.
The scanned image will appear in the PhotoStudio window.



- 9** Save the scanned image.
Click the [File] menu and select [Save As]. Select the folder where you wish to store the image file, enter a file name, select a file type (JPG format is recommended) and click [Save].

- 10** Click  or  (close box) in the PhotoStudio window to close it.

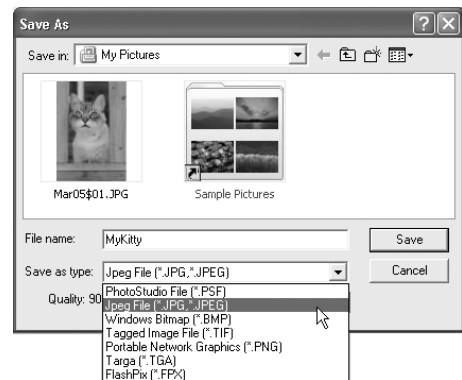

- If the scanner does not perform as described above, read the "Troubleshooting" section of the Scanning Guide.
- For details about the bundled software, read the Scanning Guide or the User's Guide (PDF format manual) for each software program on the CanoScan Setup Utility CD-ROM.

Using the Scanner Buttons

You can use the three convenient buttons on the front of the scanner to scan and perform related tasks easily with a single touch of the button. Place an item on the scanner before pressing a button



- To use these buttons, ScanGear CS, CanoScan Toolbox and ArcSoft PhotoBase should be installed from the CanoScan Setup Utility CD-ROM.

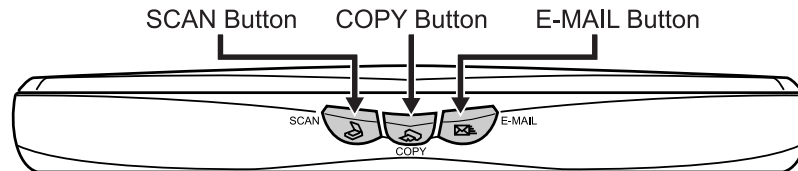

SCAN Button

To open the scanned image in the PhotoBase window:

- 1 Press the [SCAN] button.
- 2 The scanner will scan the item.
- 3 The scanned image will appear in the PhotoBase window.

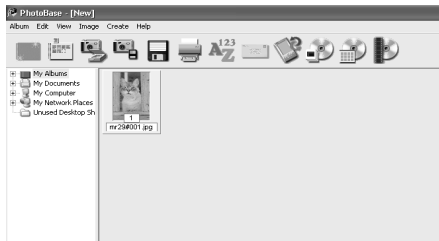

COPY Button

To print (copy) the scanned image with a printer:

- 1 Press the [COPY] button.
 - 2 The scanner will scan the item.
 - 3 The scanned image will print.
- The printer driver should be installed and the printer should be on-line to use this function.



E-MAIL Button

To e-mail the scanned image as an attached file:

- 1 Press the [E-MAIL] button.
- 2 The scanner will scan the item.
- 3 The [E-mail software selection] dialog will appear. Select an option from the list and click [OK].
This step is required only for the first scan.
- 4 The e-mail software will start and the scanned image will be attached in a new message window.
- 5 Enter the receiver's address and title, write a message, confirm the required settings, and send the message.

- The e-mail software such as Outlook Express, Microsoft Outlook, Eudora or Netscape Messenger should be installed and enabled. With certain e-mail programs, you should enable MAPI function (for Windows).



- While scanning, you can change the default settings for scanning by clicking the [Cancel] button. For changing settings or arranging the scanner button assignments, refer to the CanoScan Toolbox section of Scanning Guide (HTML format manual).

Using the Scanner in the Upright Position

Installing the Stand

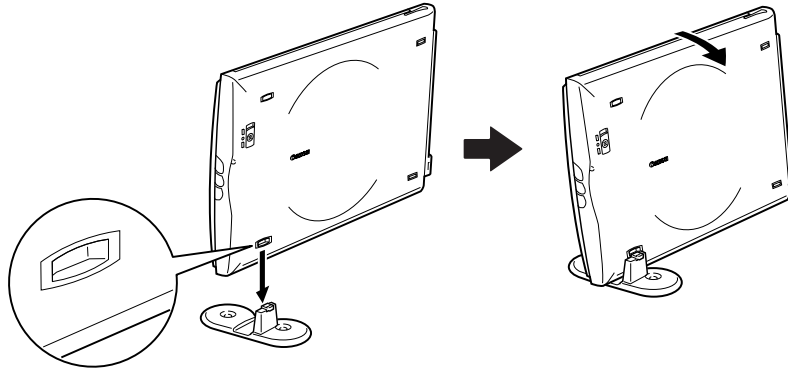

Positioning an Item

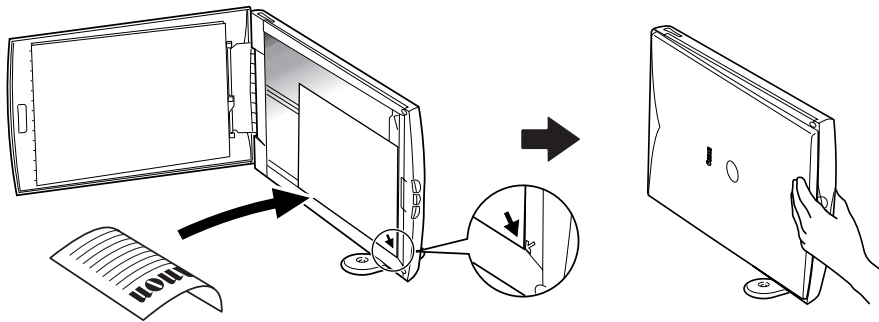

Removing the Stand

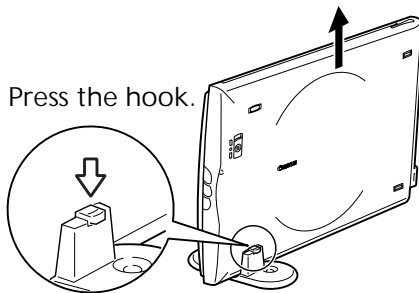

System Information

This form should be used to record the operating environment for the purchased scanner. If any problems occur with the scanner, you will need this information when you contact our Customer Support Help Desk. Be sure to record the information and store it in a safe location.

- This information is also required to request a repair under warranty. Make sure you record the information and store it in a safe location.
- Guaranteed servicing for this equipment will expire five years after production ceases.

Date of Purchase:

Dealer Tel:

Dealer Address:

Scanner Model: CanoScan LiDE 20 LiDE 30

Serial Number (on the back of the equipment):

• About the Computer Used

Manufacturer:

Model:

CPU:

Clock Speed:

MHz

Memory Capacity (RAM):

MB

Hard Disk Capacity:

MB

Space Available:

MB

OS: Windows XP Me 2000 98

 Macintosh OS 9.0 OS 9.1 OS 9.2 OS X v10.1

Monitor Type:

Monitor Size:

inches

Printer:

Manufacturer:

Type of Printer:

Printer Resolutions:

Installed Virus Protection Program:

Installed Compression Program:

On-Board Expansion Cards:

Attached Peripherals:

Connected Network System:

Specifications

		CanoScan LiDE 20	CanoScan LiDE 30
Scanner Type		Flatbed	
Scanning Element		CIS (Contact Image Sensor)	
Light Source		3-color (RGB) LED	
Optical Resolution		600 x 1200 dpi	1200 x 2400 dpi
Selectable Resolution		25 - 9600 dpi (ScanGear CS)	
Scanning Bit Depth	Color	16 bit input / 8 bit output for each color (RGB)	
	Grayscale	16 bit input/8 bit output	
Scanning Speed ^{*1}	Color	16 msec/line (600 dpi)	16 msec/line (600 dpi) 32 msec/line (1200 dpi)
	Grayscale	5.3 msec/line (600 dpi)	5.3 msec/line (600 dpi) 10.6 msec/line (1200 dpi)
	B&W	5.3 msec/line (600 dpi)	5.3 msec/line (600 dpi) 10.6 msec/line (1200 dpi)
Preview Speed ^{*2}		15 sec (approx.)	
Interface		USB 1.1	
Maximum Document Size		A4/Letter: 216 x 297mm (8.5 x 11.7 in.)	
Scanner Buttons		3 buttons: SCAN, COPY, E-MAIL	
Operating Range	Temperature	5° to 35° C (41° to 95° F)	
	Humidity	10% to 90% RH (without condensation formation)	
Power Requirements		Supplied via USB port	
Power Consumption		In operation: 2.5 watts maximum Stand-by: 1.25 watts	
Maximum Exterior Dimensions		256 x 383 x 34mm (10.1 x 15.1 x 1.3 in.)	
Weight		Approximately 1.5 kg (3.3 lbs.)	

*1 Transfer time to computer is not included.

*2 Calibration processing time is not included.

- Specifications are subject to change without notice.



• Before you upgrade to Windows XP from Windows 98/Me/2000, you must uninstall ScanGear CS and CanoScan Toolbox using the "Uninstall the Software" menu of the CanoScan Setup Utility CD-ROM. The scanner may not work if you upgrade to Windows XP with these programs still installed. After upgrading to Windows XP, reinstall ScanGear CS and CanoScan Toolbox according to the steps on page 4. For details, please read the "Troubleshooting" section of the Scanning Guide (HTML format manual).