

Canon

PIXMA MX700 series

Network Setup Guide

This manual contains the setup information required to use the machine over wired LAN.
If you use the machine with USB connection, refer to your setup sheet.

Introduction

To use the machine connected to a computer, you need to install the software called "MP Drivers" in the computer.

The following two connection types are described in this manual.

Important

- A hub and LAN cable are required to connect this machine to a LAN. These must be purchased separately.
- If the installation and adjustment of the machine have not been finished, refer to your setup sheet to set up the machine properly.

Note

- The configuration and the type of the device vary depending on your network environment. For details, refer to your device's instruction manual or contact its manufacturer.
- In an office setup, consult your network administrator.

Setting up for use over LAN

When the machine has not been connected to the network, perform this setup to use the machine over LAN. This setup procedure requires settings to be performed on the machine and the computer.

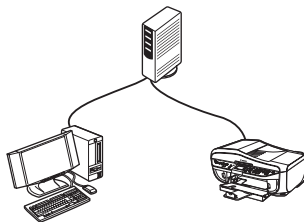

Note

- To set up the machine that is not yet connected to a LAN, connect the machine and the computer with a USB cable.
- Even if the machine has been set up to be used with the USB connection, follow the setup procedure described in this manual to connect the machine to a LAN for the first time.



QT51386V01

Setting up an additional LAN-connected computer

When the machine has already been set up to connect to the network using a computer, perform this setup to use the machine from an additional computer over LAN. This setup procedure only requires settings to be performed on the additional computer.

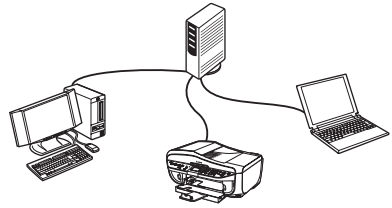

Trademark Notices

- “Microsoft” is a registered trademark of Microsoft Corporation.
- “Windows” is a trademark of Microsoft Corporation, registered in the U.S. and other countries.
- “Windows Vista” is a trademark of Microsoft Corporation.
- “Macintosh” and “Mac” are trademarks of Apple Inc., registered in the U.S. and other countries.

Confirming the Network Environment

- Turn off the firewall function temporarily or change its setting. If you disable the firewall function, disconnect your network from the Internet.
- Make sure that the configuration of computers, hubs, and other network devices is complete, and computers can connect to the network.

Important

After setup is complete, turn back on any security functions you disabled for setup. If you connect to a network that is not protected with security measures, there is a risk of disclosing data such as your personal information to a third party.

Note

- For information on the firewall function of your security software, refer to its instruction manual or contact its manufacturer.
- In an office setup, consult your network administrator.
- **If you are using Windows®**
See “Setting Up the Machine and the Computer (Windows)” on page 4.
- **If you are using Macintosh®**
See “Setting Up the Machine and the Computer (Macintosh)” on page 17.

Setting Up the Machine and the Computer (Windows)

- Before installing the MP Drivers, disable all anti-virus programs and automatically loading programs.
- Log into a user account with the administrator privilege.
- A message asking for your confirmation to restart your computer may appear during the installation process. If this message is displayed, follow the on-screen instructions and click **OK**. The installation resumes from where it left off when your computer has been restarted. While restarting, do not remove the *Setup CD-ROM*.

Important

Depending on the country or region of purchase, the following two CD-ROMs are included in the package for the Windows setup.

- Windows (CD-1)
- Windows (CD-2) Macintosh

In this case, insert the *Setup CD-ROM* “Windows (CD-1)” first to start the installation, and follow the on-screen instructions to complete the installation.

Note

The screens below refer to Windows Vista™ operating system Ultimate Edition (hereafter referred to as “Windows Vista”) installation. Screens may vary depending on the operating system you are using and also depending on the country or region of purchase.

1 Installing the software

Note

If the **Found New Hardware** or **Found New Hardware Wizard** screen appears automatically during the installation process, remove the USB cable connected to your computer. Click **Cancel** to quit the screen. In Windows Vista, the screen may close automatically when the USB cable is unplugged. Then turn off the machine and proceed from step 3 to install the MP Drivers.



- 1 Turn off the machine.

Note

Make sure that the **Power** lamp is turned off.

- 2 Turn the computer on and start Windows.

3 Insert the *Setup CD-ROM*.

The setup program should run automatically.

In Windows Vista, go to step 4.

In Windows XP and Windows 2000, go to step 6.

Important

If two CD-ROMs are included in the package for the Windows setup, insert the *Setup CD-ROM "Windows (CD-1)"*.

Note

- If the **Select Language** screen appears, select a language, then click **Next**.
- If the **Select Your Place of Residence** screen appears, select your place of residence, then click **Next**.

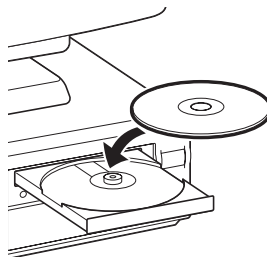

4 If the **AutoPlay** screen appears, click **Run Msetup4.exe**.



5 If the **User Account Control** screen appears, click **Continue**.

If the same screen reappears in subsequent steps, click **Continue**.

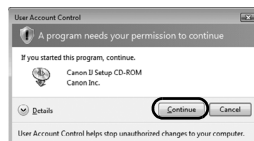

6 When the screen shown on the right appears, click **Easy Install**.

The MP Drivers, On-screen Manuals, and application software are installed automatically.

Note

If you want to select particular items to install, click **Custom Install** and follow the on-screen instructions to proceed with the installation.

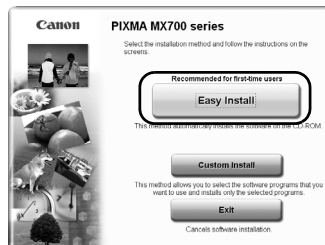

7 When the **Easy Install** screen appears, confirm the contents, then click **Install**.

Note

- Move the cursor over items to display explanations of each application.
- The list of applications may vary depending on the country or region of purchase.

Users in Asia

- Scan Soft OmniPage SE can be installed only on an English operating system.

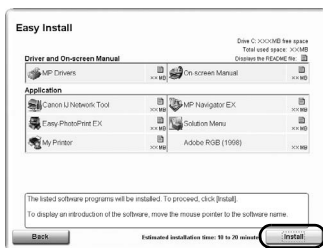

8 Read the License Agreement carefully and click **Yes**.

Installation of the MP Drivers, On-screen Manuals, and application software will begin.

The software installation screen may appear during the installation process. Follow the on-screen instructions to install the software.

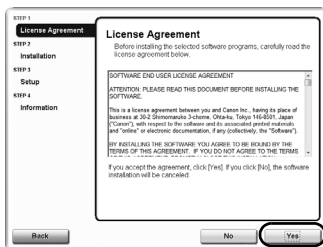

9 Confirm the connection type.

The next procedure varies depending on how you intend to connect the machine and the computer.

Setting up for use over LAN

See “2-A Setting up for use over LAN” on page 7.

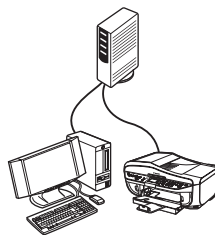

Setting up an additional LAN-connected computer

See “2-B Setting up an additional LAN-connected computer” on page 12.

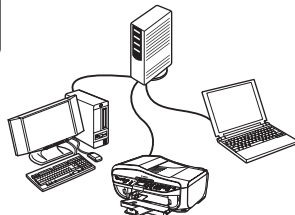

To use a USB connection, refer to your setup sheet.

2-A Setting up for use over LAN

This section describes how to set up the machine to be used over wired LAN, when the machine has not been connected to the network. This setup procedure requires settings to be performed on the machine and the computer.

- 1 On the **Setup Method** screen, select **Set up the printer and the computer for network use**, then click **Next**.

Note

If you select **Use the printer via USB**, the machine is set up to be used with USB connection.

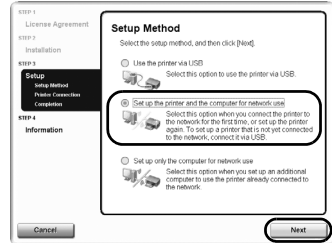

- 2 When the **Printer Connection** screen appears, connect the machine to the computer with a USB cable, then turn on the machine.

When the machine is turned on, the **Power** lamp lights up green. When the computer detects the machine, the next screen will appear automatically.

When using Windows 2000:

When you connect the machine to the computer with a USB cable, a message asking for your confirmation to restart your computer is displayed. Click **Yes**. Then when an error message is displayed, click **OK** to proceed with the installation.

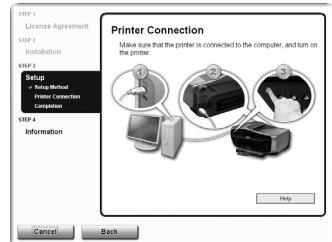

Note

- To set up the machine that is not yet connected to a LAN, connect the machine and the computer with a USB cable.
- If you cannot go to the next procedure after 3 minutes, refer to “Cannot Install the MP Drivers” in “Troubleshooting” in the *User’s Guide* on-screen manual.

- 3 When the **Setup Preparations** dialog box appears, confirm that preparation is complete, then click **Next**.

Note

If the machine’s network settings are already configured, the **Setup Environment Confirmation** dialog box appears asking for your confirmation to use the machine with the current settings. You can proceed with the setup using the current network settings. To do so, click **Use it as is**. To reconfigure the network settings, click **Reconfigure**.

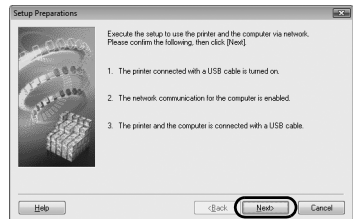

- 4 When the **Check Wired LAN Connection** dialog box appears, remove the LAN connector cap, connect the machine to the network devices such as hubs with a LAN cable, then click **Yes**.

(A) Wired LAN connector

 **Note**

The connection may vary depending on your network environment.

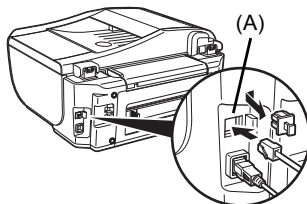

- 5 Confirm that the setup program detects the machine automatically.

The machine connected with the USB cable is detected automatically via LAN connection.

In Windows Vista, go to step 7.

In Windows XP and Windows 2000, go to step 6.

 **Note**

If the machine was not detected, the **Set Printer IP Address** dialog box appears. Make sure of the following, then click **Connect**.

- The network devices such as hubs or routers are turned on, and the machine and the computer are connected to the network.
- The machine is connected to the computer with the USB cable.
- The IP address to be set for the machine is displayed on the **Set Printer IP Address** dialog box. If it is different from the address you want to set for the machine, enter the desired IP address on the **Set Printer IP Address** dialog box.
(If the machine is turned off, the **Set Printer IP Address** dialog box does not appear.)

If it still fails, see "The Set Printer IP Address dialog box is displayed during setup" on page 29.

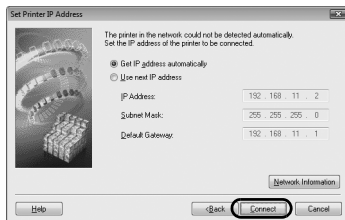

- 6 When the **Network Setup of the Card Slot** dialog box appears, specify the drive letter, then click **Next**.

 **Note**

The Card Slot of the machine must be mounted to be used as the memory card drive of the LAN-connected computer.

To write files to a memory card, set the **Read/write attribute** setting under **Device settings** to **LAN enabled**. If the setting is set to **USB enabled**, you cannot access the network drive of the Card Slot.

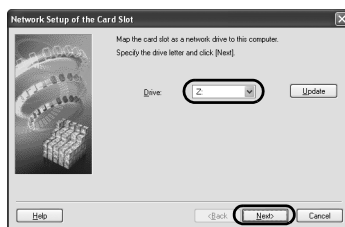

If “Communication with the Card Slot failed.” is displayed, click **Retry**. If it still fails, click **Skip** to complete the setup. Then try the network setup of the Card Slot using the Canon IJ Network Tool.

Note

- If “Cannot map any more drives, because all the drive letters are assigned.” is displayed, click **Skip** to complete the setup. After software installation is complete, remove any drive letter and try the network setup of the Card Slot again using the Canon IJ Network Tool. For details, refer to “Using the Card Slot over a Network” in the *User’s Guide* on-screen manual.
- If “The Card Slot is already mapped as Network Drive to this computer.” is displayed, the Card Slot is already set up. Click **OK**, then click **Next**.

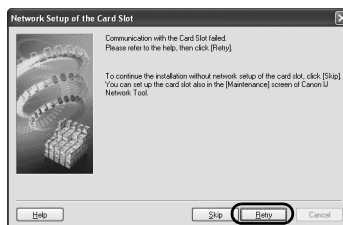

7 When the **Setup Completion** dialog box appears, remove the USB cable, then click **Finish**.

The network connection between the machine and the computer is now successfully established.

To confirm the setup results, click **View Setup Results**.

Note

- To change the port name, click **View Setup Results**, then click **Set Port Name** on the **Setup Results** dialog box. For details, refer to “Changing the Port Name” in “Troubleshooting” in the *User’s Guide* on-screen manual.
- If “Unsafe Removal of Device” is displayed, click **OK**.

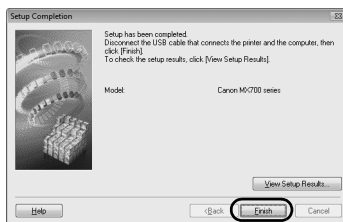

8 When the **Setup Complete** screen appears, click **Next**.



9 When the **User Registration** screen appears, click **Next**.

Note

- It is required to connect to the Internet to register your product. Turn on the firewall function before connecting your network to the Internet.
- To register later, click **Cancel** and go to step 10. After software installation is complete, double-click  on the desktop.
- The **User Registration** screen may not be displayed depending on the country or region of purchase.

If your network is connected to the Internet, the registration screen will appear. Follow on-screen instructions to register your product. You will need your product serial number, which is located on the inside of the machine.

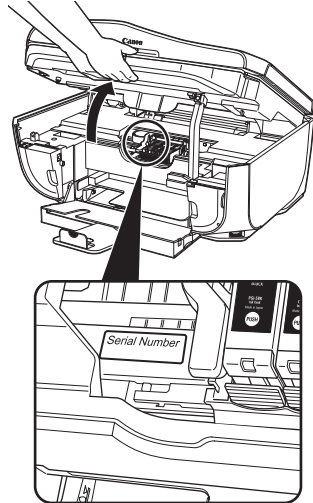

10 When the **PIXMA Extended Survey Program** screen appears, confirm the message.

We would appreciate it if you would take part in this program regarding the use of Canon printers. If you can agree, click **Agree**.

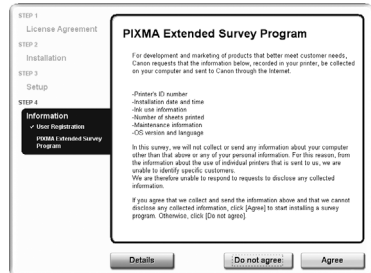

11 The Installation completed successfully screen appears.

When using Windows Vista:

To use the Card Slot over network, mount the Card Slot using the Canon IJ Network Tool after software installation is complete. For details, refer to "Using the Card Slot over a Network" in the *User's Guide* on-screen manual.

If only one CD-ROM is included in the package for the Windows setup

Click **Exit**.

After clicking **Exit**, remove the CD-ROM.

Note

- If **Restart** is displayed, make sure that the **Restart the system now (recommended)** check box is selected, then click **Restart**.
Remove the CD-ROM after clicking **Restart** and restarting the computer.
- Keep the CD-ROM in a safe place in case you need to reinstall the software.

If two CD-ROMs are included in the package for the Windows setup

When the **Continue to Windows (CD-2)** screen appears, perform the following steps (1) to (3) to complete the installation, then go to step 11.

(1) Click **Exit**.

Note

If **Restart** is displayed, make sure that the **Restart the system now (recommended)** check box is selected, then click **Restart**.

(2) Remove the *Setup CD-ROM* "Windows (CD-1)" and insert the *Setup CD-ROM* "Windows (CD-2) Macintosh".

(3) Follow the on-screen instructions to proceed with the setup.
After installation is complete, remove the CD-ROM.

Note

Keep the CD-ROMs in a safe place in case you need to reinstall the software.



2-B Setting up an additional LAN-connected computer

This section describes how to set up an additional computer to use the machine over wired LAN, when the machine has already been set up to connect to the network using another computer. This setup procedure only requires settings to be performed on the additional computer.

- 1 Make sure that the machine is connected to the network device with a LAN cable, then turn on the machine.

When the machine is turned on, the **Power** lamp lights up green.

Note

- If MAC or IP address filtering is configured to restrict access to the machine, make sure beforehand to register those addresses of the computer you are setting up.
- Make sure that the computer you are setting up is not connected to the machine with a USB cable. This setup procedure does not involve connecting the USB cable.

- 2 On the **Setup Method** screen, select **Set up only the computer for network use**, then click **Next**.

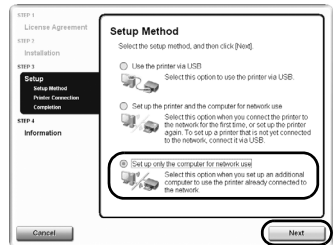

3 Confirm that the setup program detects the machine automatically.

The machine connected to the network is detected automatically.

Note

If the machine has not been detected, make sure of the following, then click **Update**.

- The machine is turned on and connected to the network device with the LAN cable.
- The machine is not set to use access control.
- The firewall function of any security software is turned off.

If the firewall function is turned on in Windows XP with Service Pack 1 or earlier, a message asking whether to turn the firewall function off is displayed during setup. If it is displayed, click **Yes** to turn it off. The firewall function is turned back on automatically after setup is complete.

- For information on how to confirm Windows XP Service Pack versions, refer to “Checking Information about the Network” in “Troubleshooting” in the *User’s Guide* on-screen manual.
- Some programs that switch the network environment depending on your system environment will enable a firewall function by default. Check the settings on any such software.

4 Select the machine on the **Printers** dialog box, then click **Next**.

In Windows Vista, go to step 6.

In Windows XP and Windows 2000, go to step 5.

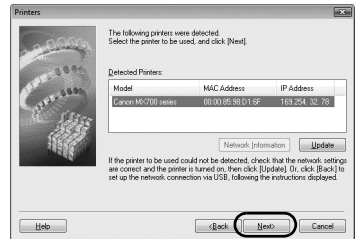

5 When the **Network Setup of the Card Slot** dialog box appears, specify the drive letter, then click **Next**.

Note

The Card Slot of the machine must be mounted to be used as the memory card drive of the LAN-connected computer.

To write files to a memory card, set the **Read/write attribute** setting under **Device settings** to **LAN enabled**. If the setting is set to **USB enabled**, you cannot access the network drive of the Card Slot.

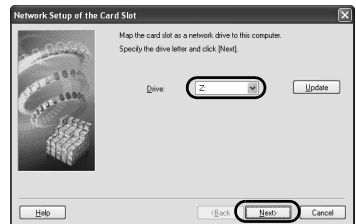

If “Communication with the Card Slot failed.” is displayed, click **Retry**. If it still fails, click **Skip** to complete the setup. Then try the network setup of the Card Slot using the Canon IJ Network Tool.

Note

- If “Cannot map any more drives, because all the drive letters are assigned.” is displayed, click **Skip** to complete the setup. After software installation is complete, remove any drive letter and try the network setup of the Card Slot again using the Canon IJ Network Tool. For details, refer to “Using the Card Slot over a Network” in the *User’s Guide* on-screen manual.
- If “The Card Slot is already mapped as Network Drive to this computer.” is displayed, the Card Slot is already set up. Click **OK**, then click **Next**.

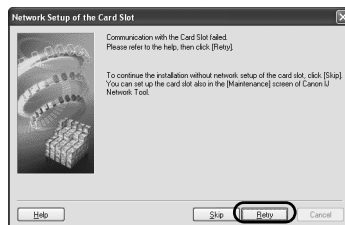

6 When the **Setup Completion** dialog box appears, click **Finish**.

The network connection between the machine and the computer is now successfully established.

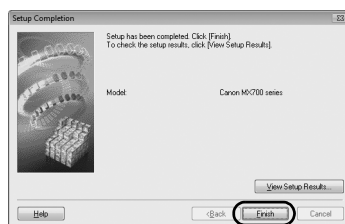

7 When the **Setup Complete** screen appears, click **Next**.

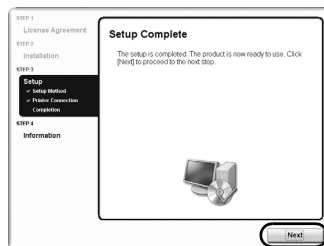

8 When the **User Registration** screen appears, click **Next**.

Note

- If you have already registered your product, click **Cancel**.
- It is required to connect to the Internet to register your product. Turn on the firewall function before connecting your network to the Internet.
- To register later, click **Cancel** and go to step 9. After software installation is complete, double-click  on the desktop.
- The **User Registration** screen may not be displayed depending on the country or region of purchase.



If your network is connected to the Internet, the registration screen will appear. Follow on-screen instructions to register your product. You will need your product serial number, which is located on the inside of the machine.

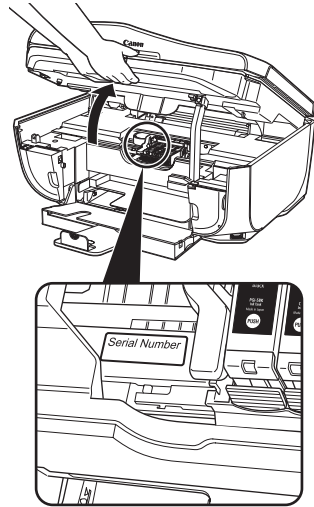

9 When the **PIXMA Extended Survey Program** screen appears, confirm the message.

We would appreciate it if you would take part in this program regarding the use of Canon printers. If you can agree, click **Agree**.

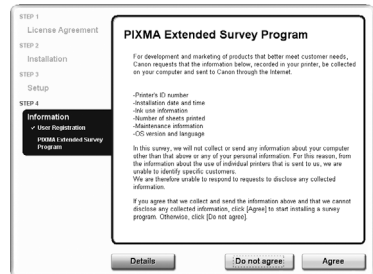

10 The Installation completed successfully screen appears.

When using Windows Vista:

To use the Card Slot over network, mount the Card Slot using the Canon IJ Network Tool after software installation is complete. For details, refer to "Using the Card Slot over a Network" in the *User's Guide* on-screen manual.

If only one CD-ROM is included in the package for the Windows setup

Click **Exit**.

After clicking **Exit**, remove the CD-ROM.



Note

- If **Restart** is displayed, make sure that the **Restart the system now (recommended)** check box is selected, then click **Restart**.
Remove the CD-ROM after clicking **Restart** and restarting the computer.
- Keep the CD-ROM in a safe place in case you need to reinstall the software.

If two CD-ROMs are included in the package for the Windows setup

When the **Continue to Windows (CD-2)** screen appears, perform the following steps (1) to (3) to complete the installation, then go to step 10.

(1) Click **Exit**.

Note

If **Restart** is displayed, make sure that the **Restart the system now (recommended)** check box is selected, then click **Restart**.

- (2) Remove the *Setup CD-ROM* "Windows (CD-1)" and insert the *Setup CD-ROM* "Windows (CD-2) Macintosh".
- (3) Follow the on-screen instructions to proceed with the setup.
After installation is complete, remove the CD-ROM.

Note

Keep the CD-ROMs in a safe place in case you need to reinstall the software.

Setting Up the Machine and the Computer (Macintosh)

- Since Mac® OS 9, Mac OS X Classic environments, or Mac OS X v.10.2.7 or earlier are not supported, do not connect the machine to these.
- Log on as an Administrator.
- Before installing the MP Drivers, disable all anti-virus programs and automatically loading programs or remove them from your system folder.

Note

The screens below refer to Mac OS X v.10.4.x installation. Screens may vary depending on the operation system you are using and also depending on the country or region of purchase.

1 Installing the software

To set up an additional LAN-connected computer, you do not need to connect it to the machine with a USB cable. Start from step 2.

- 1 Connect the machine and the computer with a USB cable.

(A) USB port

Note

Make sure that the machine is turned on.

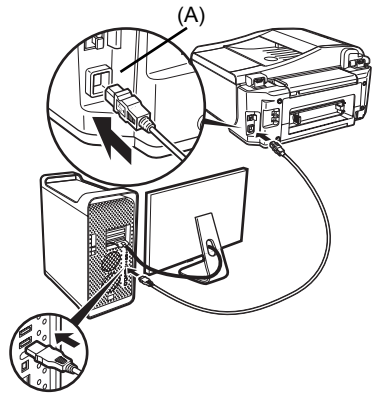

- 2 Start your Mac.
- 3 Insert the *Setup CD-ROM*.

Important

If two CD-ROMs are included in the package for the Windows setup, insert the *Setup CD-ROM "Windows (CD-2) Macintosh"* for the Macintosh setup.

Note

If the CD-ROM folder does not open automatically, double-click the CD-ROM icon  on the desktop.

4 Double-click the **Setup** icon.

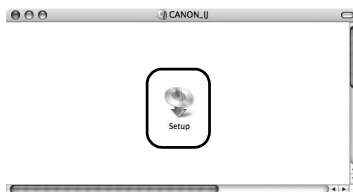

5 When the **Authenticate** screen appears, enter your administrator name and password, then click **OK**.

Note

- If you do not know your administrator name or password, click **?** on the lower-left corner of the screen, then follow the on-screen instructions.
- If the **Select Language** screen appears, select a language, then click **Next**.
- If the **Select Your Place of Residence** screen appears, select your place of residence, then click **Next**.



6 When the screen shown on the right appears, click **Easy Install**.

The MP Drivers, On-screen Manuals, and application software are installed automatically.

Note

If you want to select particular items to install, click **Custom Install** and follow the on-screen instructions to proceed with the installation.

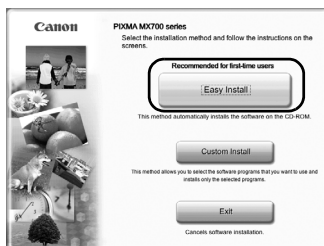

7 When the **Easy Install** screen appears, confirm the contents, then click **Install**.

Note

- Move the cursor over items to display explanations of each application.
- The list of applications may vary depending on the country or region of purchase.

Users in Asia

- To install the *User's Guide* on-screen manual in a language other than the installed one, double-click the **Manual** folder in the *Setup CD-ROM*, **Canon** folder, and then copy a language folder to your hard disk.

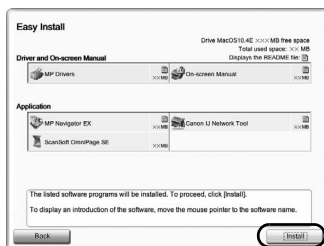

8 Read the License Agreement carefully and click **Yes**.

Installation of the MP Drivers, On-screen Manuals, and application software will begin.

The software installation screen may appear during the installation process. Follow the on-screen instructions to install the software.

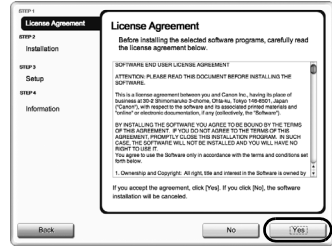

9 When the **Setup Complete** screen appears, click **Next**.

Note

The **Setup Complete** screen may not be displayed depending on the country or region of purchase.



10 When the **User Registration** screen appears, click **Next**.

Note

- It is required to connect to the Internet to register your product. Turn on the firewall function before connecting your network to the Internet.
- To register later, click **Cancel** and go to step 11. After software installation is complete, double-click  on the desktop.
- The **User Registration** screen may not be displayed depending on the country or region of purchase.

If your network is connected to the Internet, the registration screen will appear. Follow on-screen instructions to register your product. You will need your product serial number, which is located on the inside of the machine.

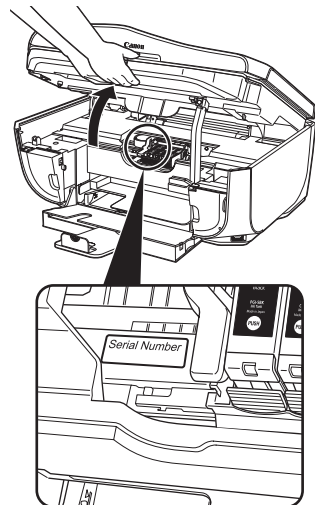
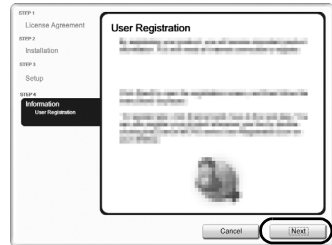

11 When the **Installation completed successfully** screen appears, click **Restart**.

Remove the CD-ROM after clicking **Restart** and restarting the computer.

Note

Keep the CD-ROM in a safe place in case you need to reinstall the software.

When the computer restarts, the Canon IJ Network Tool will start up automatically.

When using Mac OS X v.10.2.8 to v.10.3.3:

Restarting the computer while connected to the machine may cause the machine not to be detected. To resolve this, either unplug the USB cable then plug it back in again, or turn the machine off then back on again.

Note

When using Mac OS X v.10.2.8 to v.10.3.x, before using the Operation Panel on the machine to save scanned originals to the computer, it is necessary to select **MP Navigator EX** as the launch application on **Image Capture** under **Applications**. For details, refer to “Scanning Images” in the *User’s Guide* on-screen manual.



12 Confirm the connection type.

The next procedure varies depending on how you intend to connect the machine and the computer.

Setting up for use over LAN

See “2-A Setting up for use over LAN” on page 21.

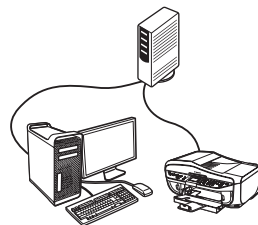

Setting up an additional LAN-connected computer

See “2-B Setting up an additional LAN-connected computer” on page 24.

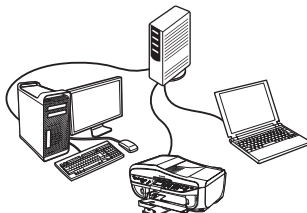

To use a USB connection, refer to your setup sheet.

2-A Setting up for use over LAN

This section describes how to set up the machine to be used over wired LAN, when the machine has not been connected to the network. This setup procedure requires settings to be performed on the machine and the computer.

- 1 On the **Canon IJ Network Tool** screen, select **LAN connection**, then click **OK**.

If the Canon IJ Network Tool does not start up automatically, select **Library > Printers > Canon > BJPrinter > Utilities > Canon IJ Network Tool**.

Note

If you select **USB connection**, the Canon IJ Network Tool will exit without setting up the machine to be used over LAN.

If the screen shown on the right appears, make sure of the following and click **OK**.

- The machine is turned on.
- The machine is connected to the computer with a USB cable.
- The MP Drivers have been installed.

- 2 Select **Setup** in the pop-up menu, select your machine's name in **Printers**, then click **OK**.

Note

- If no printer is detected, click **OK**. Make sure that the machine is connected to the computer with a USB cable and turned on, then click **Update**.
- If the machine's network settings are already configured, the **Setup Environment Confirmation** dialog box appears asking for your confirmation to use the machine with the current settings. You can proceed with the setup using the current network settings. To do so, click **Use as is**. To reconfigure the network settings, click **Reconfigure**.

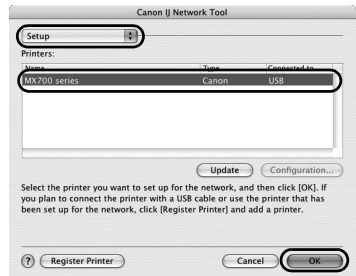
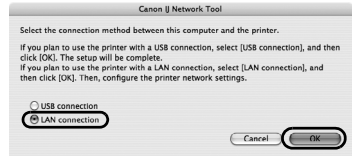

- 3 When the **Check Wired LAN Connection** dialog box appears, remove the LAN connector cap, connect the machine to the network devices such as hubs with a LAN cable, then click **Yes**.

(A) Wired LAN connector

 **Note**

The connection may vary depending on your network environment.

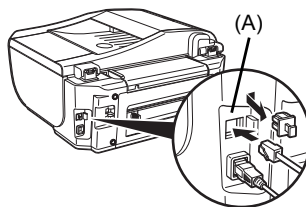

- 4 Confirm that the setup program detects the machine automatically.

The machine connected with the USB cable is detected automatically via LAN connection.

 **Note**

If the machine was not detected, the **Set Printer IP Address** dialog box appears. Make sure of the following, then click **Connect**.

- The network devices such as hubs or routers are turned on, and the machine and the computer are connected to the network.
- The machine is connected to the computer with the USB cable.
- The IP address to be set for the machine is displayed on the **Set Printer IP Address** dialog box. If it is different from the address you want to set for the machine, enter the desired IP address on the **Set Printer IP Address** dialog box.

(If the machine is turned off, the **Set Printer IP Address** dialog box does not appear.)

If it still fails, see “The Set Printer IP Address dialog box is displayed during setup” on page 29.

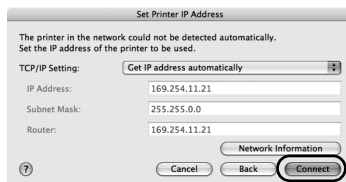

- 5 When the **Setup Completion** dialog box appears, remove the USB cable, then click **OK**.

The network connection between the machine and the computer is now successfully established.

The Printer Setup Utility (Print Center in Mac OS X v.10.2.8) and Canon IJ Network Scanner Selector will start up.

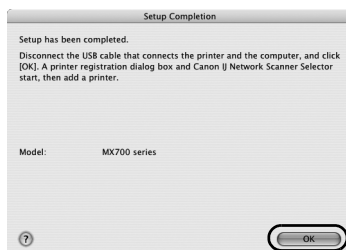

6 On the **Printer List** dialog box, click **Add**.

Note

The machine displayed in the list is the one connected with the USB cable. You need to add the machine connected to the network to the list.



7 On the **Printer Browser** dialog box, click **More Printers**.



8 Select **Canon IJ Network** in the pop-up menu, select your machine's name in the list of printers, then click **Add**.

Note

The alphanumeric string after the machine's name is its MAC address.

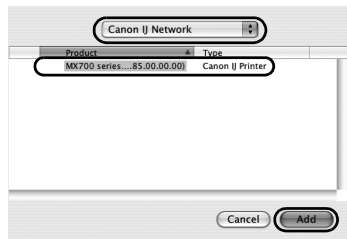

9 Confirm that your machine's name is added to the list of printers.

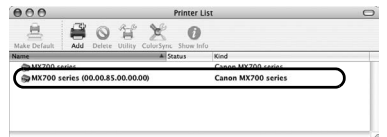

10 On the **Canon IJ Network Scanner Selector** screen, confirm that **Canon XXX Network** (where **XXX** is your machine's name) is selected in **TWAIN Data Source Name** and a check mark is displayed on the MAC address of the machine in **Network Device List**, then click **Exit** to close the dialog box.

If a check mark is not displayed, select the MAC address of the machine in **Network Device List**, then click **Apply** to use the machine as a scanner.



Note

- To confirm the machine's MAC address, display the machine's network setting information referring to "Displaying and Initializing Network Settings" in the *User's Guide* on-screen manual.
- For details on how to scan, refer to the *User's Guide* and *Scanning Guide* on-screen manuals.

11 After the MP Drivers are installed, start up the Canon IJ Network Tool to mount the Card Slot.

For details on the network setup of the Card Slot, refer to "Using the Card Slot over a Network" in the *User's Guide* on-screen manual.

2-B Setting up an additional LAN-connected computer

This section describes how to set up an additional computer to use the machine over wired LAN, when the machine has already been set up to connect to the network using another computer. This setup procedure only requires settings to be performed on the additional computer.

1 Make sure that the machine is connected to the network device with a LAN cable.

Note

- If MAC or IP address filtering is configured to restrict access to the machine, make sure beforehand to register those addresses of the computer you are setting up. To register the addresses, use the Canon IJ Network Tool on the computer that has already been set up.
- Make sure that the computer you are setting up is not connected to the machine with a USB cable. This setup procedure does not involve connecting the USB cable.

2 On the **Canon IJ Network Tool** screen, select **LAN connection**, then click **OK**.

If the Canon IJ Network Tool does not start up automatically, select **Library > Printers > Canon > BJPrinter > Utilities > Canon IJ Network Tool**.

Note

If you select **USB connection**, the Canon IJ Network Tool will exit without setting up the machine to be used over LAN.

3 When the screen shown on the right appears, click **OK**.

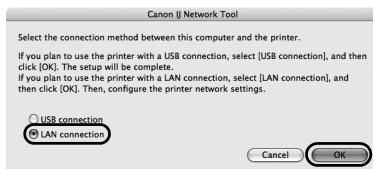

- 4 Select **Setup** in the pop-up menu, then click **Register Printer**.

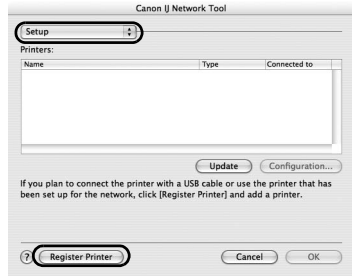

- 5 When the **Cancel Setup** screen appears, click **Cancel**.

The Printer Setup Utility (Print Center in Mac OS X v.10.2.8) and Canon IJ Network Scanner Selector will start up.



If "You have no printers available." is displayed, click **Cancel**.

- 6 On the **Printer List** dialog box, click **Add**.



- 7 On the **Printer Browser** dialog box, click **More Printers...**



- 8 Select **Canon IJ Network** in the pop-up menu, select your machine's name in the list of printers, then click **Add**.

 **Note**

- The alphanumeric string after the machine's name is its MAC address.
- If the machine has not been detected, make sure of the following.
 - The machine is turned on and connected to the network device with the LAN cable.
 - The machine is not set to use access control.
 - The firewall function of any security software is turned off.

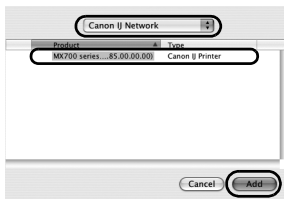

- 9 Confirm that your machine's name is added to the list of printers.



- 10 On the **Canon IJ Network Scanner Selector** screen, confirm that **Canon XXX Network** (where "XXX" is your machine's name) is selected in **TWAIN Data Source Name** and a check mark is displayed on the MAC address of the machine in **Network Device List**, then click **Exit** to close the dialog box.

If a check mark is not displayed, select the MAC address of the machine in **Network Device List**, then click **Apply** to use the machine as a scanner.

 **Note**

- To confirm the machine's MAC address, display the machine's network setting information referring to "Displaying and Initializing Network Settings" in the *User's Guide* on-screen manual.
- For details on how to scan, refer to the *User's Guide* and *Scanning Guide* on-screen manuals.

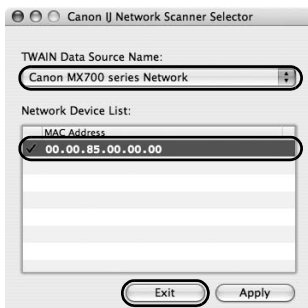

- 11 After the MP Drivers are installed, start the Canon IJ Network Tool to mount the Card Slot.

For details on the network setup of the Card Slot, refer to "Using the Card Slot over a Network" in the *User's Guide* on-screen manual.



Troubleshooting

This section describes troubleshooting tips for problems you may encounter when setting up.

Note

If you do not find a description for your trouble here, refer to “Troubleshooting” in the *User’s Guide* on-screen manual.

Troubles in setup/connections

- “Cannot connect to the machine (the machine is not detected)” on page 28
 - “The machine is not detected” on page 28
 -  “No printer is detected after the network settings are changed” on page 28
- “The following screen is displayed during setup” on page 29
 - “The Set Printer IP Address dialog box is displayed during setup” on page 29
 - “The Enter Password or Password Input dialog box is displayed during setup” on page 30
 - ““Communication with the Card Slot failed.” is displayed during the network setup of the Card Slot” on page 31
 -  ““The Card Slot is already mapped as Network Drive to this computer.” is displayed during setup” on page 32
 -  ““Cannot map any more drives, because all the drive letters are assigned.” is displayed during the network setup of the Card Slot” on page 32

Other troubles



Refer to “Troubleshooting” in the *User’s Guide* on-screen manual.

Cannot connect to the machine (the machine is not detected)

Problem	Possible Cause and Measures
The machine is not detected	<ul style="list-style-type: none">● Make sure that the machine is turned on.● Firewall function provided by security software may prevent proper setup or communication over a network. When setting up the machine to be used over a network, disable any firewall function provided by security software during the setup. If the firewall function is turned on in Windows XP with Service Pack 1 or earlier, a message asking whether to turn the firewall function off is displayed during setup. If it is displayed, click Yes to turn it off. The firewall function is turned back on automatically after setup is complete. For information on how to confirm Windows XP Service Pack versions, refer to "Checking Information about the Network" in "Troubleshooting" in the <i>User's Guide</i> on-screen manual.
 No printer is detected after the network settings are changed	Wait until the IP address is assigned to the computer. Search for the machine again after confirming a valid IP address is assigned to the computer.

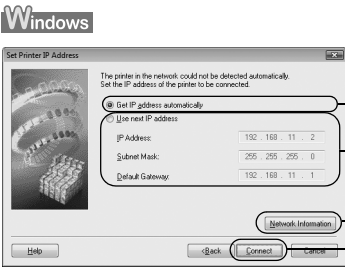
The following screen is displayed during setup

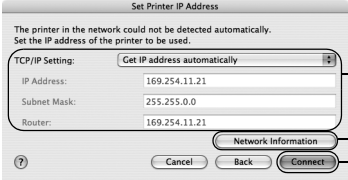
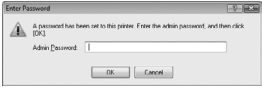
Problem	Possible Cause and Measures
<p>The Set Printer IP Address dialog box is displayed during setup</p>	<p>The following dialog box is displayed if no printer was detected on the network. Specify the IP address of the machine and click Connect to retry the detection of the machine.</p>  <p>The IP address currently set for the machine is displayed on the dialog box.</p> <p>(1) Get IP address automatically Select to use an IP address provided by a DHCP server. This requires that the DHCP function is enabled on the router.</p> <p>(2) Use next IP address Select to manually specify an IP address, for example if there is no DHCP server functionality in the network environment in which you are using the machine.</p> <p>IP Address/Subnet Mask/Default Gateway Enter each value to specify a fixed IP address when Use next IP Address is selected.</p> <p>(3) Network Information Click to display the Network Information dialog box, and confirm network settings when your machine cannot be detected automatically during setup for use over the network.</p> <p>(4) Connect Click to search for the machine with the specified settings. If the machine is still not detected with a specified IP address, see "Cannot connect to the machine (the machine is not detected)" on page 28.</p>

Problem	Possible Cause and Measures
<p>The Set Printer IP Address dialog box is displayed during setup (Continued)</p>	<p>Macintosh</p>  <p>The IP address currently set for the machine is displayed on the dialog box.</p> <p>(1) TCP/IP Setting</p> <p>Select Get IP address automatically or Use following IP address.</p> <p>Select Get IP address automatically to use an IP address provided by a DHCP server. This requires that the DHCP function is enabled on the router.</p> <p>Select Use following IP address to manually specify an IP address, for example if there is no DHCP server functionality in the network environment in which you are using the machine.</p> <p>IP Address/Subnet Mask/Router</p> <p>Enter each value to specify a fixed IP address when Use following IP address is selected.</p> <p>(2) Network Information</p> <p>Click to display the Network Information dialog box, and confirm network settings when your machine cannot be detected automatically during setup for use over the network.</p> <p>(3) Connect</p> <p>Click to search for the machine with the specified settings. If the machine is still not detected with a specified IP address, see “Cannot connect to the machine (the machine is not detected)” on page 28.</p>
<p>The Enter Password or Password Input dialog box is displayed during setup</p>	<p>The following dialog box is displayed if an administrator password is set to the machine which has already been set up.</p> <div style="display: flex; justify-content: space-around;"> <div data-bbox="415 874 676 1015"> <p>Windows</p>  </div> <div data-bbox="710 874 1009 1031"> <p>Macintosh</p>  </div> </div> <p>Admin Password</p> <p>Enter the administrator password you have set. The administrator password consists of alphanumeric characters and is no longer than 32 characters. The password is case sensitive.</p> <p>For security, your entry will be displayed by “*” (asterisks) in Windows and “•” (bullets) in Macintosh.</p>

Problem

"Communication with the Card Slot failed." is displayed during the network setup of the Card Slot

Possible Cause and Measures

This message is displayed if installation of the network drive for the Card Slot fails during setup.

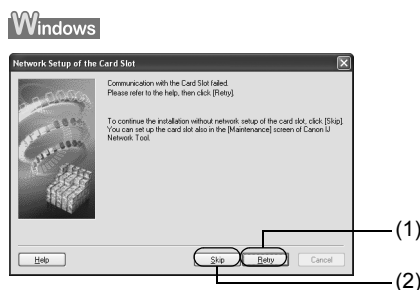

(1) Retry

Click to retry the network setup of the Card Slot.

(2) Skip

Click to continue installation without the network setup of the Card Slot.

When this message is displayed, wait for a while, then click **Retry**. If it fails again, follow the procedure below.

- Make sure that the computer is communicating with the network properly, then try again.
- When using Windows Vista, mount the Card Slot using the Canon IJ Network Tool after software installation is complete. For details, refer to "Using the Card Slot over a Network" in the *User's Guide* on-screen manual.
- Disable the Windows Firewall function, or open port 137:139 to allow communication with the machine following the procedure below. For information on other security software, refer to its instruction manual or contact its manufacturer.

Important

If you disabled the firewall function, disconnect your network from the Internet. To do this, configure your router not to connect to the Internet or WAN.

To disable the Windows Firewall:

(1) Click **Start > Control Panel > Security Center > Windows Firewall**.

(2) Select **Off**, and click **OK**.

To open port 137:139:

(1) Click **Start > Control Panel > Security Center > Windows Firewall**.

(2) Select the **Advanced** tab, select the target connection, and click **Settings**.

(3) Select the **Services** tab, and click **Add**.

(4) On the **Service Settings** dialog box, input the following information, and click **OK**.

Description of service: Input the name of this service.

Name or IP address: Input the IP address of the machine. For details, refer to "Displaying and Initializing Network Settings" in the *User's Guide* on-screen manual.





External Port number for this service: Input "137".

TCP/UDP: Select TCP.

Internal Port number for this service: Input the same number as External Port number.

(5) Repeat steps (1) to (3). On the **Service Settings** dialog box, input the same information as you did in step (4) except for selecting UDP in **TCP/UDP**.

(6) Use the same procedure to open the other ports (138TCP, 138UDP, 139TCP, and 139UDP).

Problem	Possible Cause and Measures
<p>"Communication with the Card Slot failed." is displayed during the network setup of the Card Slot (Continued)</p>	<p>If the setup is in progress, click Skip to complete the setup. Then mount the Card Slot using the Canon IJ Network Tool.</p> <ul style="list-style-type: none"> ● Change the workgroup name to "WORKGROUP" following the procedure below. <ol style="list-style-type: none"> (1) Right-click My Computer, then select Properties. (2) Select the Computer Name tab, then click Change. (3) Change the workgroup name to "WORKGROUP", then click OK. <p> Important</p> <p>If you change the firewall or workgroup settings of the computer during the setup, you may be prompted to restart the computer to enable the settings. In this case, click Skip to complete the setup without changing any settings. You can set up the Card Slot in the Maintenance screen of the Canon IJ Network Tool after changing the necessary settings and restarting the computer. For details, refer to "Using the Card Slot over a Network" in the <i>User's Guide</i> on-screen manual.</p> <p>If these do not resolve the problem, click Skip to complete the setup without the network setup of the Card Slot. To mount the Card Slot as the network drive after setup, refer to "Troubles in the Network Setup of the Card Slot" in "Troubleshooting" in the <i>User's Guide</i> on-screen manual.</p> <p> Macintosh</p> <ul style="list-style-type: none"> ● Make sure that a memory card is inserted in the Card Slot. If it is not inserted, insert it. <p> Note</p> <p>Depending on the Mac OS version, the authentication screen may appear. If it appears, click OK.</p> <p>If these do not resolve the problem, click Skip to complete the setup without the network setup of the Card Slot. To mount the Card Slot as the network drive after setup, refer to "Troubles in the Network Setup of the Card Slot" in "Troubleshooting" in the <i>User's Guide</i> on-screen manual.</p>
<p> Windows</p> <p>"The Card Slot is already mapped as Network Drive to this computer." is displayed during setup</p>	<p>The Card Slot is already available. Click OK to close the dialog, then click Next on the Network Setup of the Card Slot dialog box.</p>
<p> Windows</p> <p>"Cannot map any more drives, because all the drive letters are assigned." is displayed during the network setup of the Card Slot</p>	<p>Click Skip to complete the setup. After software installation is complete, remove any drive letter and try the network setup of the Card Slot again using the Canon IJ Network Tool. For details, refer to "Using the Card Slot over a Network" in the <i>User's Guide</i> on-screen manual.</p>