

Canon

SPEEDLITE
430EX III-RT

SPEEDLITE
430EX III



**INSTRUCTION
MANUAL**

Introduction

The Canon Speedlite 430EX III-RT/430EX III is an EOS-dedicated external Speedlite, compatible with E-TTL II/E-TTL autoflash systems.

Wireless Flash Shooting		430EX III-RT	430EX III
Radio transmission wireless function	Sender	○	—
	Receiver	○	—
Optical transmission wireless function	Sender	—	—
	Receiver	○	○

Before Starting to Shoot, Be Sure to Read the Following

To avoid botched pictures and accidents, first read the “Safety Precautions” (pages 8-9).

Read This Instruction Manual While Also Referring to Your Camera’s Instruction Manual

Before using the product, read this instruction manual and your camera’s instruction manual to familiarize yourself with their operations.

Using the Speedlite with a Camera

● Using with an EOS DIGITAL camera (Type-A camera)

You can use the Speedlite for easy flash shooting by autoflash control in the same way as a camera’s built-in flash.

● Using with an EOS film camera

● An EOS camera with E-TTL II/E-TTL autoflash metering system (Type-A camera)

You can use the Speedlite for easy flash shooting by autoflash control in the same way as a camera’s built-in flash.

● An EOS camera with TTL autoflash metering system (Type-B camera)

See page 102.

* This instruction manual assumes that the Speedlite is used with a Type-A camera.

Cautions when using continuous flash

Flashes will fire repeatedly in continuous shooting using a flash, multi-flash shooting, modeling flash, etc. Some people may experience seizures, etc. due to visual overstimulation from continuous flashes (including light reflected off brightly colored walls, etc.). Stop using flashes immediately if any symptoms emerge.

Chapters









	Introduction	2
1	Getting Started and Basic Operations Preparing for flash shooting and basic flash shooting	15
2	Advanced Flash Photography Advanced shooting utilizing the flash shooting functions	23
3	Setting Flash Functions with Camera Operations Setting the flash functions from the camera's menu screen	39
4	Wireless Flash Photography: Radio Transmission Wireless (sender/receiver) flash shooting using radio transmission	45
5	Wireless Flash Photography: Optical Transmission Wireless (receiver) flash shooting using optical transmission	71
6	Customizing the Speedlite Customizing with Custom Functions and Personal Functions	79
7	Reference System map, Troubleshooting guide, Using with a type-B camera	89







When using a “Speedlite 430EX III”, which is not equipped with the radio transmission function, the wireless flash shooting described in Chapter 4 is not available. To shoot with the optical transmission wireless flash using the receiver function, see Chapter 5.

Conventions Used in this Manual







Icons in this Manual



-  : Indicates the Select dial.
- <ZOOM> <MODE> : < > Indicates the top, bottom, left, and right buttons of the cross keys.
- < > < > : Indicates the Select/Set button.
-  : Indicates that the respective function remains active for approx. 12 sec. or 16 sec. after you let go of the button.
-  : Reference page numbers for more information.
- (p.**)
-  : Warning to prevent shooting problems.
-  : Supplemental information.
- ☆ : ☆ shown on the upper right of the page title indicates that the function is performed when the camera's shooting mode is set to <P>, <Tv>, <Av>, <M>, or (Creative Zone mode).

Basic Assumptions

- The operation procedures assume that both the Speedlite and the camera's power switches are set to ON.
- The icons used for buttons, dials, and symbols in the text match the icons found on the Speedlite and the camera.
- The selection operation performed when setting a function basically describes selecting a function by turning < >. A selection can also be made by pressing the top, bottom, left, and right (<ZOOM> <MODE> < > < > buttons) of the < > cross keys.
- When you want to end function setup, press the < > button.
- The operation procedures assume that the Custom Functions and Personal Functions of the Speedlite, and the menu and Custom Functions of the camera are at their default settings.
- All figures are based on the use of four AA/LR6 alkaline batteries and Canon's testing standards.
- The explanations use Speedlite 430EX III-RT illustrations.

Contents

Introduction	2
Chapters	3
Conventions Used in this Manual	4
Index to Features	7
Safety Precautions	8
Nomenclature	10
Accessories provided	14
1 Getting Started and Basic Operations	15
Installing the Batteries	16
Attaching and Detaching the Speedlite to and from the Camera	17
Turning on the Power	18
ETTL : Fully Automatic Flash Photography	20
E-TTL II/E-TTL Autoflash by Shooting Mode	21
2 Advanced Flash Photography	23
 Flash Exposure Compensation	24
FEL: FE Lock	25
 High-speed Sync	26
 Second-curtain Sync	27
 Bounce	28
Catchlight Shooting	29
 Bounce Adapter	30
Zoom : Setting the Flash Coverage	32
Wide Panel	33
M : Manual Flash	34
Modeling Flash	36
 Color Filter	37
Clearing Speedlite Settings	38
3 Setting Flash Functions with Camera Operations	39
Flash Control from the Camera's Menu Screen	40

4	Wireless Flash Photography: Radio Transmission	45
	(P) Radio Transmission Wireless Flash Shooting	46
	Wireless Settings.....	50
	ETTL : Fully Automatic Wireless Flash Shooting	55
	A:B : Wireless Multiple Flash Shooting with Flash Ratio.....	59
	M : Wireless Multiple Flash Shooting with Manual Output	62
	Gr : Shooting in a Different Flash Mode for Each Group	63
	Test Flash and Modeling Flash with a Receiver Unit	65
	Remote Release from a Receiver Unit.....	66
	Linked Shooting with Radio Transmission	67
5	Wireless Flash Photography: Optical Transmission	71
	Optical Transmission Wireless Flash Shooting.....	72
	Wireless Settings.....	73
	ETTL : Fully Automatic Wireless Flash Shooting	75
	 Manual Flash Setting on a Receiver Unit	78
6	Customizing the Speedlite	79
	C.Fn / P.Fn : Setting Custom and Personal Functions.....	80
	C.Fn : Setting Custom Functions.....	83
	P.Fn : Setting Personal Functions.....	86
7	Reference	89
	430EX III-RT/430EX III System.....	90
	 Flash Firing Restriction due to Temperature Increase	92
	Troubleshooting Guide	94
	Specifications	98
	Using with a Type-B Camera	102
	Radio Transmission Wireless Function	103
	Index.....	106

Index to Features

Power Source

- Batteries → p.16
- Firing interval/frequency → p.16
- Power ON/OFF → p.18
- Flash ready → p.18
- Quick flash → p.18
- Auto power off → p.18

Operations

- Attaching and detaching the Speedlite → p.17
- Lock function → p.19
- LCD panel illumination → p.19

Normal Shooting

- Full auto (E-TTL) → p.20
- Autoflash by shooting mode → p.21
- Manual flash → p.34

Functions

- Flash exposure compensation → p.24
- FE lock → p.25
- High-speed sync → p.26
- Second-curtain sync → p.27
- Modeling flash → p.36
- AF-assist beam → p.22
- Flash coverage → p.32
 - Wide panel → p.33
- Bounce → p.28
 - Catchlight → p.29
 - Adapter → p.30

- Color filter → p.37
- Clearing settings (Reverting to defaults) → p.38
- Flash function settings → p.39
- Flash firing restriction → p.92
- Type-B camera → p.102

Radio Transmission Wireless Flash Photography

- Full auto → p.55
- Manual flash → p.62
- Group flash → p.63
- Test flash/Modeling flash → p.65
- Remote release → p.66
- Linked shooting → p.67
- Memory function → p.54

Optical Transmission Wireless Flash Photography

- Full auto → p.75
- Memory function → p.74
- Individual receiver → p.78

Customization

- Custom Functions (C.Fn) → p.83
- Personal Functions (P.Fn) → p.86
- Clear all → p.82

Safety Precautions

The following precautions are provided to prevent harm or injury to yourself and others. Make sure to thoroughly understand and follow these precautions before using the product.

If you experience any malfunctions, problems, or damage to the product, contact the nearest Canon Service Center or the dealer from whom you purchased the product.



Warnings: Follow the warnings below. Otherwise, death or serious injuries may result.

- To prevent fire, excessive heat, chemical leakage, explosions, and electrical shock, follow the safeguards below:
 - Do not insert any foreign metallic objects into the electrical contacts of the product, accessories, connecting cables, etc.
 - Do not use any batteries, power sources, or accessories not specified in the Instruction Manual. Do not use any deformed or modified batteries.
 - Do not short-circuit, disassemble, or modify the product or batteries. Do not apply heat or solder to the battery. Do not expose the battery to fire or water. Do not subject the battery to strong physical shock.
 - Do not insert the battery's plus and minus ends incorrectly, or mix new batteries with used ones or batteries of different type.
- Do not use the product in locations where there is flammable gas. This is to prevent an explosion or a fire.
- Do not fire the flash at anyone driving a car or other vehicle. It may cause an accident.
- Do not disassemble or modify the equipment. High-voltage internal parts can cause electrical shock.
- If you drop the equipment and the casing breaks open to expose the internal parts, do not touch the internal parts. There is a possibility of an electrical shock.
- Do not store the product in dusty or humid places or location with lots of oil smoke. This is to prevent a fire or electrical shock.
- Before using this product inside an airplane or hospital, check if it is allowed. Electromagnetic waves emitted by the product may interfere with the plane's instruments or the hospital's medical equipment.
- If the battery leaks, changes color, deforms, or emits smoke or fumes, remove it immediately. Be careful not to get burned in the process. It may cause a fire, electrical shock or skin burn if you keep using it.
- Keep the battery and other accessories out of the reach of children and infants. If a child or infant swallows a battery or accessory, consult a physician immediately. (Battery chemicals may harm the stomach and intestines.)
- Be careful not to get the product wet. If you drop the product in the water or if water or metal get inside the product, promptly remove the battery. This is to prevent a fire and an electrical shock.
- Do not cover or wrap the product with a cloth. Doing so may trap heat within and cause the casing to deform or catch fire.

- Keep the equipment out of the reach of children and infants, including when in use. Straps or cords may accidentally cause choking, electrical shock, or injury. Choking or injury may also occur if a child or infant accidentally swallows a part or accessory. If a child or infant swallows a part or accessory, consult a physician immediately.
- When the equipment is not in use, make sure to remove the battery, and disconnect the external power source and cable from the equipment before storing. This is to prevent electrical shock, excessive heat, fire, or corrosion.
- Prevent any battery leakage from contacting your eyes, skin, and clothing. It can cause blindness or skin problems. If the battery leakage contacts your eyes, skin, or clothing, flush the affected area with lots of clean water without rubbing it. See a physician immediately.
- Do not use paint thinner, benzene, or other organic solvents to clean the product. Doing so may cause fire or a health hazard.
- Do not fire the flash near a person's eyes. It may impair the person's vision. When using flash to photograph an infant, keep at least 1 meter/3.3 feet away.



Cautions: Follow the cautions below. Otherwise physical injury or property damage may result.

- When the product is not in use for a prolonged period, make sure to remove the battery before storing. This is to prevent malfunction or corrosion.
- When disposing of a battery, insulate the electrical contacts with tape to prevent contact with other metallic objects or batteries. This is to prevent a fire or an explosion.
- Do not use, store, or leave the product in a vehicle in the direct sunlight or with interior of a high-temperature, or near a high-temperature object. The product may become hot and cause skin burns if touched. Doing so may also cause battery heat generation, breakage, leakage, and the like.
- Do not fire the flash with the flash head (light-emitting unit) contacted a human body or any object. Doing so may result in the risk of burn and fire.
- Do not leave the product in a low-temperature environment for an extended period of time. The product will become cold and may cause injury when touched.
- Do not directly touch any part of the product that becomes hot. Long contact on the skin may result in low temperature contact burns.
- If you replace the batteries after continually firing, the batteries may be hot. Be careful not to get burned in the process. It may cause a skin burn.

Nomenclature

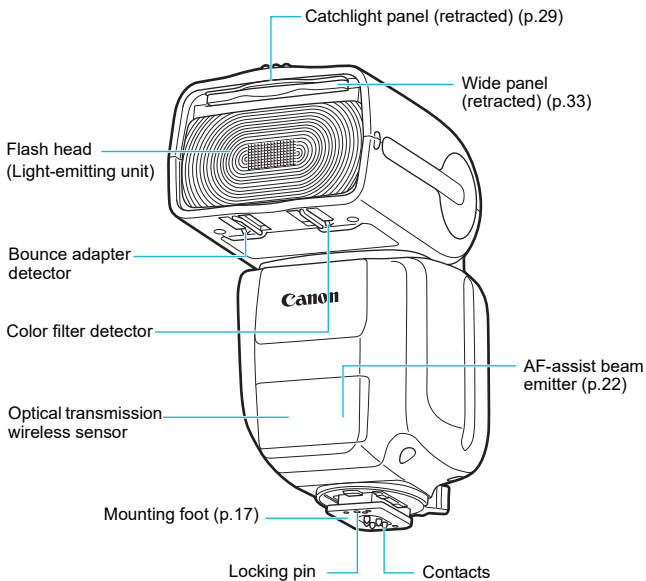

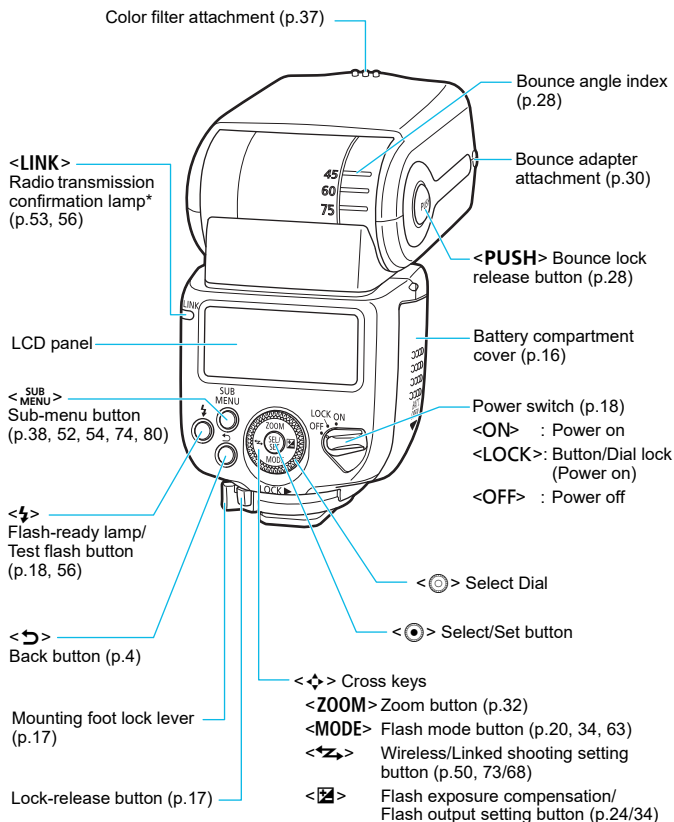

* Not available with Speedlite 430EX III.

LCD Panel

E-TTL II/E-TTL Autoflash (p.21)

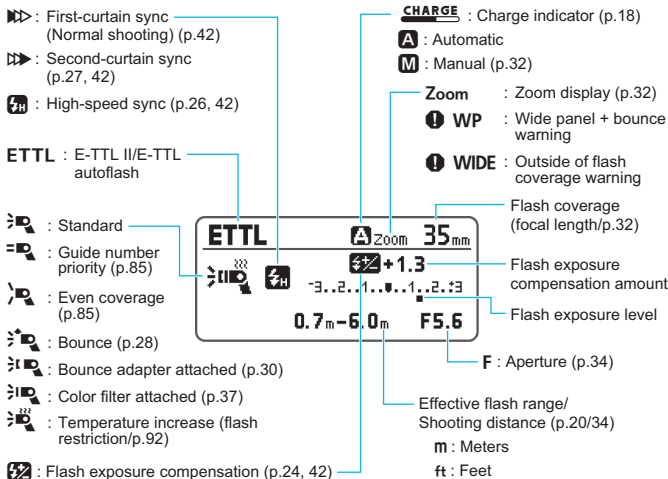

Manual Flash (p.34)

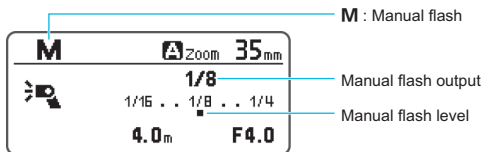

- The displays shown are examples. The display will show only the settings currently applied.
- When a button or dial is operated, the LCD panel illuminates (p.19).
- With **<Gr>** group flash (p.13), select the flash mode from **<ETTL>**, **<M>**, **<Ext.A>** (auto external flash), and **<OFF>**.

Radio Transmission Wireless Shooting/ Optical Transmission Wireless Shooting

(p.45/71)

● Radio transmission wireless: Sender unit (430EX III-RT only)

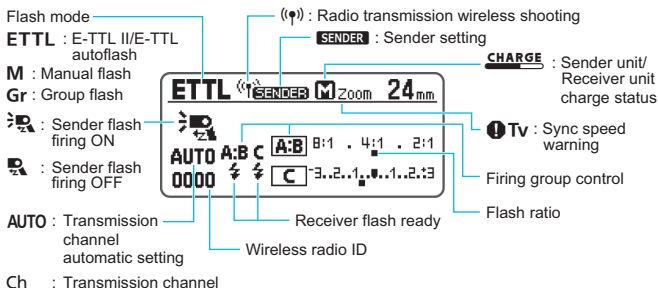

● Radio/Optical transmission wireless: Receiver unit

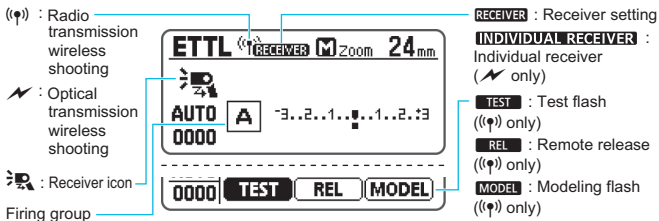

Radio Transmission: Linked Shooting

(430EX III-RT only/p.67)

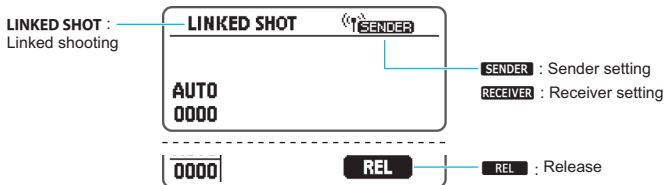

Accessories provided (Common to 430EX III-RT/430EX III)

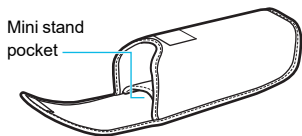

Speedlite case

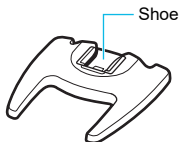

Mini stand
(p.47, 72)



Bounce adapter
SBA-E2
(p.30)



Color filter SCF-E2
(p.37)



**Bounce adapter/
color filter case**

1

Getting Started and Basic Operations

This chapter describes the preparations before starting flash photography and the basic shooting operations.

Cautions for firing continuous flash

- To avoid degrading and damaging the flash head due to overheating, do not fire more than 20 continuous flashes. After 20 continuous flashes, allow a rest time of at least 10 min.
- If you fire 20 continuous flashes, and then fire the flash again repeatedly with short intervals, the safety function may activate and restrict flash firing. While flash firing is restricted, the firing interval is automatically set to approx. 8 to 25 sec. If this happens, allow a rest time of at least 20 to 30 min.
- For details, see “Flash Firing Restriction due to Temperature Increase” on page 92.

Installing the Batteries

Install four AA/R6 batteries for power supply.

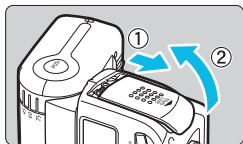

1 Open the cover.

- Slide the battery compartment cover down, then open the battery compartment cover.

2 Install the batteries.

- Make sure the “+” and “-” battery contacts are correctly oriented as shown in the battery compartment.

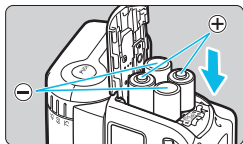

3 Close the cover.

- Close the battery compartment cover and slide it up by following the procedure of step 1 in reverse.

Firing Interval and Number of Flashes

Firing Interval		Number of Flashes
Quick Flash	Normal Flash	
Approx. 0.1 to 2.5 sec.	Approx. 0.1 to 3.5 sec.	Approx. 180 to 1200 times

- Based on new AA/LR6 alkaline batteries and Canon's testing standards.
- The Quick flash function enables flash shooting before the flash is fully charged (p.18).

⚠ CAUTION

● **Do not use AA/R6 lithium batteries.**

Note that certain AA/R6 lithium batteries may become extremely hot in rare cases during usage. Due to safety reasons, do not use “AA/R6 lithium batteries”.

● **When continually firing, do not touch the flash head, batteries, or the area near the battery compartment.**

When continuous flash or modeling flash is repeatedly fired with short intervals, do not touch the flash head, battery, or the area near the battery compartment. The flash head, batteries, and area near the battery compartment become hot, resulting in the risk of burn.

● **Do not use the Speedlite while touching the same part for a long period of time.**

Even if the product does not feel too hot, prolonged contact with the same body part may cause skin redness, blistering or low-temperature contact burns. Using a tripod is recommended for people with circulation problems or very sensitive skin, or when using the product in very hot places.



Using AA/R6 batteries other than the alkaline type may cause contact failure due to the irregular shape of the battery contacts.



- When  is displayed or the LCD panel display turns off during recycling, replace the batteries with new ones.
- Use a new set of four batteries of the same brand. When replacing the batteries, replace all four at one time.
- AA/HR6 Ni-MH batteries can also be used.

Attaching and Detaching the Speedlite to and from the Camera

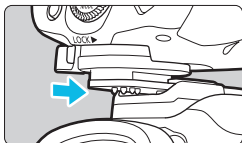

1 Attach the Speedlite.

- Slip the Speedlite's mounting foot **all the way** into the camera's hot shoe.

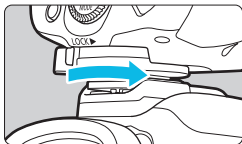

2 Secure the Speedlite.

- Slide the mounting foot lock lever to the right.
- ▶ When the lock lever clicks in place, it is locked.

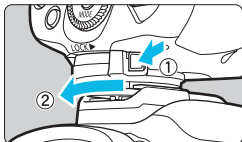

3 Detach the Speedlite.

- While pressing the lock-release button, slide the lock lever to the left and detach the Speedlite from the camera.



Be sure to turn off the Speedlite before attaching or detaching it.

Turning on the Power

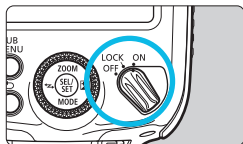

1 Set the power switch to <ON>.

- ▶ The flash recycling starts.
- ▶ During recycling, < **CHARGE** > is displayed on the LCD panel. When flash recycling is complete, this indicator disappears.

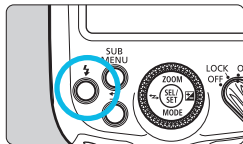

2 Check that the flash is ready.

- The status of the flash-ready lamp changes from **off** to **green** (Quick flash ready) to **red** (fully charged).
- You can press the test flash button (flash-ready lamp) to fire a test flash.

Quick Flash

The Quick flash function enables flash shooting when the flash-ready lamp is lit green (before the flash is fully charged). Quick flash is available regardless of the camera's drive mode setting. The flash output will be approx. 1/2 to 1/3 of the full output, but it is effective for shooting with a shorter firing interval. During manual flash shooting, this function is available when the flash output is set to 1/4 to 1/128. Note that you cannot use Quick flash during wireless flash shooting.

Auto Power Off

To save battery power, the power will turn off automatically after approx. 90 sec. of idle use. To turn on the Speedlite again, press the camera's shutter button halfway or press the test flash button (flash-ready lamp).

During radio transmission wireless sender flash shooting (p.57) or during linked shooting (p.69), the time until auto power off takes effect is approx. 5 min.

ⓘ A test flash cannot be fired when the camera's $\frac{1}{4}$ / $\frac{1}{6}$ / $\frac{1}{8}$ / $\frac{1}{10}$ / $\frac{1}{16}$ timer is active.

ⓘ For the display of < **CHARGE** > when set as the sender unit during radio transmission wireless shooting, see page 54.

Lock Function

By setting the power switch to <LOCK>, you can disable the flash's button and dial operations. It is effective when you want to prevent the flash function settings from being accidentally changed after you set them. If you operate a button or dial, <LOCKED> is displayed on the LCD panel.

LCD Panel Illumination

When a button or dial is operated, the LCD panel illuminates for approx. 12 sec (12). When setting a function, the illumination continues until the setting is complete.

During normal flash shooting, when set as the sender unit in radio transmission flash shooting (p.46), or when set as the "sender camera unit" in linked shooting (p.67), the LCD panel illuminates in green. When it is set as a receiver unit in wireless flash shooting or when set as a "receiver camera unit" in linked shooting, the LCD panel illuminates in orange.

For the LCD panel illumination when set as the sender unit during radio transmission wireless shooting, see page 54.

 When Quick flash is fired during continuous shooting, underexposure may occur since the flash output decreases.

- 
- The flash settings will remain in effect even after the power is turned off. To retain the settings when replacing the batteries, replace the batteries within 1 min. after turning off the power switch and removing the batteries.
 - When the temperature of flash head has risen due to continuous flash firing, the time until auto power off takes effect may increase.
 - You can fire a test flash while the power switch is set to <LOCK>. Also, when a button or dial is operated, the LCD panel illuminates.
 - Auto power off can be disabled (C.Fn-01/p.83).
 - You can change the setting of the LCD panel illumination (C.Fn-22/p.85).
 - You can change the color of the LCD panel illumination (P.Fn-02 to 04/p.86).
 - You can disable Quick flash (P.Fn-06/p.87).

ETTL: Fully Automatic Flash Photography

When you set the camera's shooting mode to <P> (Program AE) or fully automatic mode, you can shoot in E-TTL II/E-TTL fully automatic flash mode.

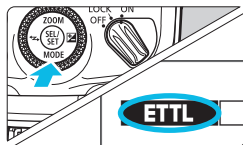

1 Set the flash mode to <ETTL>.

- Press the <MODE> button of the <◀▶> cross keys.
- Turn <◁> to select <ETTL>, then press <○>.



2 Focus on the subject.

- Press the shutter button halfway to focus.
- ▶ The shutter speed and aperture are displayed in the viewfinder.
- Check that <⚡> is lit in the viewfinder.

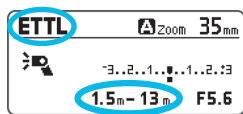

Effective flash range

3 Take the picture.

- Check that the subject is in the effective flash range.
- When you press the shutter button completely, the flash will fire and the picture will be taken.

- If the subject is dark (underexposed) when you check the shot image, move closer to the subject and shoot again. You can also increase the ISO speed when using a digital camera.
- “Fully automatic mode” refers to <A+>, <□>, and <CA> shooting modes.
- Even when attached to a camera that supports the E-TTL II autoflash system, <ETTL> is displayed on the LCD panel.

E-TTL II/E-TTL Autoflash by Shooting Mode

Simply set the camera's shooting mode to <Tv> (shutter-priority AE), <Av> (aperture-priority AE), or <M> (manual exposure) and you can use E-TTL II/E-TTL autoflash suitable for each shooting mode.

Tv	Select this mode when you want to set the shutter speed manually. The camera will then automatically set the aperture matching the shutter speed to obtain a standard exposure based on the metering of the camera. <ul style="list-style-type: none">● If the aperture display blinks, it means that the background exposure will be underexposed or overexposed. Adjust the shutter speed until the aperture display stops blinking.
Av	Select this mode when you want to set the aperture manually. The camera will then automatically set the shutter speed, matching the aperture to obtain a standard exposure based on the metering of the camera. If the scene is dark, a slow sync speed will be used to obtain a standard exposure for both the main subject and background. Standard exposure of the main subject is obtained with the flash light, while a standard exposure of the background is obtained with a long exposure using a slow shutter speed. <ul style="list-style-type: none">● Since a slow shutter speed will be used for low-light scenes, using a tripod is recommended.● If the shutter speed display blinks, it means that the background exposure will be underexposed or overexposed. Adjust the aperture until the shutter speed display stops blinking.
M	Select this mode if you want to set both the shutter speed and aperture manually. Standard exposure of the main subject is obtained with the flash light. The exposure of the background is obtained with the shutter speed and aperture combination you set.

- If you use the <DEP> or <A-DEP> shooting mode, the result will be the same as using the <P> (Program AE) mode.

Flash Sync Speeds and Apertures by Shooting Mode

	Shutter Speed	Aperture
P	Automatically set (1/X sec. - 1/60 sec.)	Automatically set
Tv	Manually set (1/X sec. - 30 sec.)	Automatically set
Av	Automatically set (1/X sec. - 30 sec.)	Manually set
M	Manually set (1/X sec. to 30 sec., Bulb)	Manually set

- 1/X sec. is the camera's maximum flash sync speed.

Auto Zoom Adjustment to Image Sensor Size

EOS DIGITAL cameras have three sizes of image sensors, and the effective focal length of the attached lens varies depending on the model. 430EX III-RT/430EX III automatically recognizes the image sensor size of the EOS DIGITAL camera and automatically sets the flash coverage that is ideal for the effective focal length of the lens in the range of 24-105 mm.

Color Temperature Information Transmission

This function optimizes the white balance during flash shooting by transmitting the color temperature information to the EOS DIGITAL camera when the flash fires. When you set the camera's white balance to <AWB> or <☀>, the function is enabled automatically.

Refer to the specifications in your camera's instruction manual to find out if it is compatible with this function.

AF-Assist Beam

When it is difficult to autofocus on the subject in low-light or when contrast is low during viewfinder shooting, intermittent flashes (a series of small flashes) are emitted to help autofocus. The effective range of the AF-assist beam is approx. 0.7 - 4 m/2.3 - 13.1 ft. at center and approx. 0.7 - 3.5 m/2.3 - 11.5 ft. at periphery in the viewfinder.

- 
 - The AF-assist beam, which uses a series of small flashes, is emitted when 430EX III-RT/430EX III is attached to an EOS DIGITAL camera with a function for controlling external flashes from the camera's menu screen. Note that, depending on the camera model, the camera's firmware may need to be updated.
 - When the color filter is attached (p.37), the AF-assist beam, which uses a series of small flashes, is not emitted. If AF-assist beam is required, set P.Fn-05-1 (p.87).

- 
 - During Live View shooting, the AF-assist beam, which uses a series of small flashes, is emitted even when the AF method is set to [Quick AF].
 - AF-assist beam firing can be disabled (C.Fn-08/p.84).
 - Infrared AF-assist beam can be emitted (P.Fn-05/p.87).

2

Advanced Flash Photography

This chapter describes advanced shooting operations utilizing the flash functions.



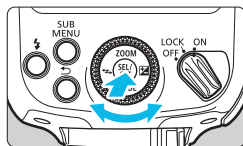
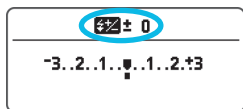
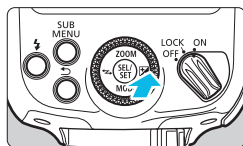

 When the camera's shooting mode is set to a fully automatic mode or a Basic Zone mode, the functions with ☆ added to the right side of the page title cannot be set. Set the camera's shooting mode to <P>, <Tv>, <Av>, <M>, or (Creative Zone mode) to enable all the operations in this chapter.

Flash Exposure Compensation [☆]



With a similar procedure as exposure compensation, you can adjust the flash output. The flash exposure compensation amount can be set up to ± 3 stops in 1/3-stop increments.







1 Press the button.

- Press the  button of the  cross keys.
- You can also select a flash exposure compensation symbol by pressing  and turning .

2 Set the flash exposure compensation amount.

- Turn  to set the flash exposure compensation amount, then press .
- ▶ The flash exposure compensation amount is set.
- "0.3" indicates 1/3 stop and "0.7" indicates 2/3 stops.
- To cancel flash exposure compensation, return the compensation amount to ± 0 .

- 
- Generally, set an increased exposure compensation for bright subjects and set a decreased exposure compensation for dark subjects.
 - If the camera's exposure compensation is set in 1/2-stop increments, flash exposure compensation will be up to ± 3 stops in 1/2-stop increments.
 - When the flash exposure compensation is set on both the flash and the camera, priority is given to the flash setting.
 - Without pressing the  button of the  cross keys, you can directly turn  and set the amount of flash exposure compensation (C.Fn-13/p.84).

FEL: FE Lock ☆

The FE (Flash Exposure) lock locks the correct flash exposure setting for any part of the scene.

While <ETTL> is displayed on the LCD panel, press the camera's <M-Fn> button. For cameras without a <M-Fn> button, press the <★> (AE lock) or <FEL> button.



1 Focus on the subject.

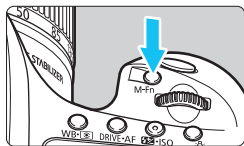

2 Press the <M-Fn> button. (Ⓜ16)

- With the subject at the center of the viewfinder, press the camera's <M-Fn> button.
- ▶ The Speedlite will fire a preflash and the required flash output for the subject is retained in memory.
- ▶ “FEL” will be displayed in the viewfinder for approx. 0.5 sec.
- Each time you press the <M-Fn> button, a preflash will be fired and the new flash output required at that time is retained in memory.



- If a correct exposure cannot be obtained when FE lock is performed, <⚡> blinks in the viewfinder. Move closer to the subject or open the aperture, and perform FE lock again. You can also set a higher ISO speed and perform FE lock again when using a digital camera.
- If the target subject is too small in the viewfinder, FE lock may not be effective.

High-speed Sync [☆]

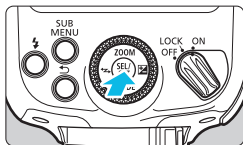

With high-speed sync, you can shoot with a flash even at shutter speeds that exceed the maximum flash sync speed. This is convenient when you want to shoot in the aperture-priority AE <Av> mode (open aperture) with background blur in locations such as outdoors in daylight.



1 Press <>.





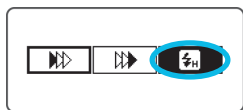

2 Select the symbol in the illustration.



- Turn <> to select the symbol shown in the illustration, then press <>.



3 Select <>.

- Turn <> to select <>, then press <>.
- Check that <> is lit in the viewfinder, then shoot.

 With high-speed sync, the faster the shutter speed, the lower the guide number will be. You can check the effective flash range on the LCD panel.

- When the shutter speed is less than or equal to the maximum flash sync speed, <> is not displayed in the viewfinder.
- To return to normal flash shooting, select <> (first-curtain sync) in step 3. (<> will not be displayed on the LCD panel after you perform this setting.)

▶▶ Second-curtain Sync ☆

Shooting with a slow shutter speed and second-curtain sync captures the trajectory of the light sources of a moving subject, such as car lights, in a natural way. The flash fires right before the exposure finishes (shutter closes).

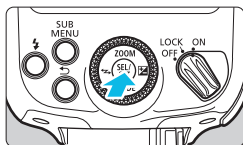

1 Press <⊙>.



2 Select the symbol in the illustration.

- Turn <⊙> to select the symbol shown in the illustration, then press <⊙>.

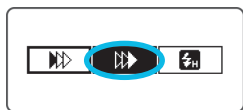

3 Select <▶▶>.

- Turn <⊙> to select <▶▶>, then press <⊙>.



- The second-curtain sync works well when the camera's shooting mode is set to (bulb shooting).
- When the flash mode is set to <ETTL>, the flash fires twice. The first flash is a preflash to determine the flash output. It is not a malfunction.
- Second-curtain sync is not available during wireless flash shooting.
- To return to normal flash shooting, select <▶▶> (first-curtain sync) in step 3. (<▶▶> will not be displayed on the LCD panel after you perform this setting.)

Bounce

By pointing the flash head toward a ceiling or wall, the flash light will bounce off the surface before illuminating the subject, making it possible to soften the shadows of the subject for a more natural-looking shot. This shooting method is called “Bounce shooting”.

Set the Bounce Direction

- You can turn the flash head while pressing the <PUSH> button as shown. When you turn the flash head, the display changes to .
- When the flash head is turned while the flash coverage is set to <A> (automatic), the flash coverage is set at 50 mm and <--> is displayed.
- You can also set the flash coverage manually (p.32).

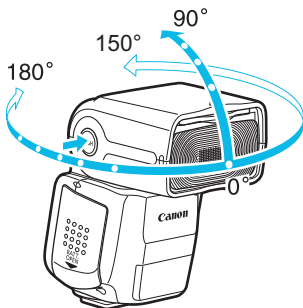

- If the ceiling or wall is too far away, shooting with the appropriate exposure may not be possible since the bounced flash may be too weak.
- If the picture appears dark, use a larger aperture opening (smaller f/ number) and try again. You can also increase the ISO speed when using a digital camera.
- The ceiling or wall should be plain white for high reflectance. If the bounce surface is not white, shooting with the appropriate exposure may not be possible, since a color cast may result in the picture or the bounced flash may be too weak.
- When Quick flash is fired in bounce shooting, underexposure may occur since the flash output decreases.

- Since the flash guide number decreases in bounce shooting, focusing with AF-assist beam using a series of small flashes may not be possible. During bounce shooting, using infrared AF-assist beam is recommended (P.Fn-05-1/p.87).

Catchlight Shooting

Using the catchlight panel when shooting a portrait enables you to capture reflected light in a person's eyes and create a more vivid expression.

1 Turn the flash head 90° up.

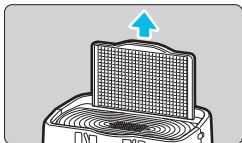

2 Pull up the wide panel.

- Pull up the protruding area located in the center of the wide panel.
- ▶ The white catchlight panel is pulled out at the same time.

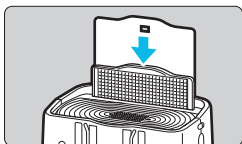

3 Push back the wide panel.

- Push back the wide panel only, keeping just the catchlight panel upward.
- Shoot using the same method as bounce shooting.

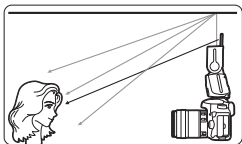

- Position the flash head toward the front and 90° up. When the flash head is rotated to the left or right, the catchlight is not very effective.
- To effectively obtain the catchlight in a person's eyes, shoot within approx. 1.5 m/4.9 ft. (at ISO 100) from the subject.
- Do not pull up the wide panel with excessive force. Doing so may detach the wide panel from the Speedlite.

Bounce Adapter

If you attach the provided bounce adapter to the Speedlite and bounce the flash light on the ceiling or wall, etc., you can spread the flash light across a larger area and suppress the shadows of the subject.

Also, if the flash head is turned 90° upward to bounce the flash light on the ceiling, etc., the diffused flash light emitted out of the side facing the subject will be casted on the front of the subject (shooting distance guidance: within approx. 1.5 m/4.9 ft., at ISO 100), further suppressing the shadow of the subject. When shooting portraits, catchlight effect can also be obtained.

"Canon" logo

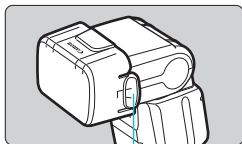
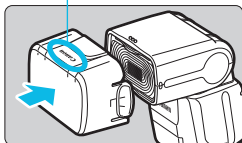

Removal tab

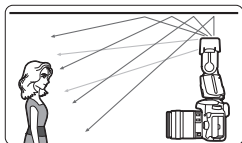
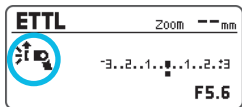

1 Attach the bounce adapter.

- Attach the adapter securely to the flash head until it clicks in place, as shown.
- Check that the display changes to .
- When removing the adapter, lift the left and right removal tabs and remove the adapter from the flash head.

2 Take the picture.

- Take the picture with the flash light bouncing off the ceiling, walls or the like.



- When the bounce adapter is attached, or when the bounce adapter and the wide panel are used together, underexposure may result since the flash output decreases. Take necessary countermeasures such as increasing ISO speed on the camera or applying flash exposure compensation (p.24).
- Since the flash guide number decreases when the bounce adapter is attached, focusing with AF-assist beam using a series of small flashes may not be possible. Using infrared AF-assist beam is recommended (P.Fn-05-1/p.87).
- When Quick flash (p.18) is fired with the bounce adapter attached, taking the picture after the flash-ready lamp is lit in red is recommended since the flash output may not be sufficient.
- The flash coverage is set automatically when the bounce adapter is attached. You cannot change the setting.
- If you attach the bounce adapter to the flash when using an EOS DIGITAL camera released up to 2004, set the white balance to <AWB>. If you shoot with <⚡>, appropriate white balance may not be obtained.



- The flash light is further softened when the wide panel (p.33) is used together.
- If the subject is dark (underexposed) when you check the shot image, perform the flash exposure compensation (p.24). You can also increase the ISO speed when using a digital camera.

Zoom: Setting the Flash Coverage [☆]

Flash coverage (the range covered by the flash light) can be set automatically or manually. With the **<A>** (automatic) setting, the flash coverage is adjusted automatically according to the focal length (shooting angle of view) of the lens in use and the image sensor size (p.22). With the **<M>** (manual) setting, you can manually set flash coverage in the range of 24 to 105 mm.

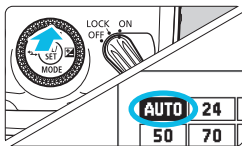

- 1 Press the **<ZOOM>** button.**
 - Press the **<ZOOM>** button of the **<◇>** cross keys.

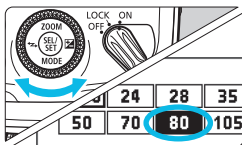

- 2 Set the flash coverage.**
 - When you want to set the flash coverage automatically, set **<AUTO>**. When you want to set the flash coverage manually, select a number (indicating the focal length in mm).
 - Turn **<⊙>** to select the flash coverage, then press **<⊙>**.

- 
- When you set the flash coverage manually, set the same or a wider coverage than the angle of view for shooting to avoid darkening the periphery of the picture.
 - When a lens with a focal length less than 24 mm is attached, the **<ⓘ WIDE>** warning is displayed on the LCD panel. When using a camera with the image sensor size smaller than full-frame, the **<ⓘ WIDE>** warning is displayed when the actual shooting angle of view is wider than the angle of view of a 24mm lens.

Wide Panel

When you use the flash's built-in wide panel together, you can perform flash shooting with ultra-wide angle lenses with a focal length up to 14 mm.

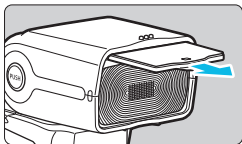

1 Pull out the wide panel.

- Pull out the protruding area located in the center of the wide panel.
- ▶ The white catchlight panel is pulled out at the same time.

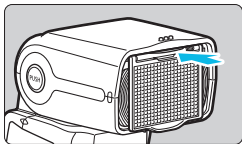

2 Push back the catchlight panel.

- Push back the catchlight panel only, keeping the wide panel down.



- Since underexposure may occur, the <⚡ WP> warning is displayed on the LCD panel when using the wide panel with bounce shooting.
- Do not pull out the wide panel with excessive force. Doing so may detach the wide panel from the Speedlite.
- Angle of view of EF15mm f/2.8 Fisheye or EF8-15mm f/4L Fisheye USM is not supported.



The flash coverage is set automatically when using the wide panel. You cannot change the setting.

M: Manual Flash ☆

You can set the flash output from 1/1 full output to 1/128 power in 1/3-step increments.

Use a flash meter (commercially available) to determine the required flash output to obtain a correct flash exposure. Setting the camera's shooting mode to <Av> or <M> is recommended.

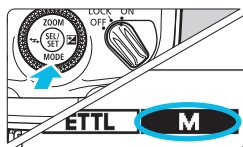

1 Set the flash mode to <M>.

- Press the <MODE> button of the <⬅➡> cross keys.
- Turn <⦿> to select <M>, then press <⦿>.

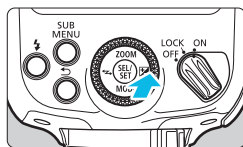

2 Set the flash output.

- Press the <⏏> button of the <⬅➡> cross keys.
- Turn <⦿> to set the flash output, then press <⦿>.

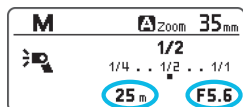
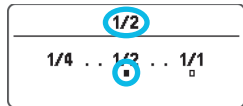

Shooting distance Aperture

- When you press the camera's shutter button halfway, an indication of the shooting distance and the aperture setting are displayed.

- For guide number details with manual flash, refer to page 101.
- Without pressing the <⏏> button of the <⬅➡> cross keys, you can directly turn <⦿> to set the amount of flash output (C.Fn-13/p.84).

Metered Manual Flash Exposures

When using an EOS-1D series camera, the flash exposure level can be manually set before shooting. This is effective when you are close to the subject. Use a 18% gray reflector (commercially available) and shoot as follows.

1 Configure the camera and Speedlite settings.

- Set the camera's shooting mode to <M> or <Av>.
- Set the Speedlite flash mode to <M>.

2 Focus on the subject.

- Focus manually.

3 Set up an 18% gray reflector.

- Place the gray reflector at the subject's position.
- Aim the camera so that the entire spot metering circle within the viewfinder center is over the gray reflector.

4 Press the <M-Fn>, <✳>, or <FEL> button. (☺16)

- ▶ The Speedlite will fire a preflash and the required flash output for the correct flash exposure is retained in memory.
- ▶ On the right side of the viewfinder, the exposure level indicator will show the flash exposure level against the standard exposure.

5 Set the flash exposure level.

- Adjust the Speedlite's manual flash output and the aperture so that the flash exposure level aligns with the standard exposure index.

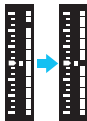

6 Take the picture.

- Remove the gray reflector and take the picture.



Metered manual flash is available only with EOS-1D series cameras.

Modeling Flash ☆

When the camera's depth-of-field preview button is pressed, the flash fires continuously for approx. 1 sec. This feature is called "modeling flash". This is effective for checking shadow effects on the subject with the flash light and the lighting balance during wireless flash shooting (p.45, 71).

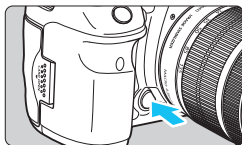

Press the depth-of-field preview button on the camera.

- ▶ The flash fires continuously for approx. 1 sec.

- ⚠ To avoid degrading and damaging the flash head due to overheating, do not fire the modeling flash more than 20 times continuously. After firing it 20 times continuously, allow a rest time for at least 10 min.
- If the modeling flash is fired more than 20 times continuously, the safety function may activate and restrict flash firing. If this happens, allow a rest time for at least 20 to 30 min.
- During Live View shooting, firing modeling flash (by operating the camera) is not possible.
- Modeling flash (by operating the camera) is disabled when using the flash with EOS M3, EOS M2, EOS M, EOS Elan II/Elan II E/50/50E, EOS REBEL 2000/300, EOS REBEL G/500N, EOS REBEL K2/3000V, EOS REBEL XS N/REBEL G II/3000N/66, EOS IX, or EOS IX Lite/IX7. Set C.Fn-02 to 1 or 2 (p.83), and fire modeling flash using the test flash button.

- 📡 During normal flash shooting or when using the flash as the sender unit in radio transmission wireless shooting, you can fire the modeling flash with the test flash button (C.Fn-02/p.83).

Color Filter

When shooting with flash under incandescent lighting (a tungsten light source), reddish, unnatural colors may result on the subject background where the flash light does not reach. By attaching the provided color filter to the flash, automatic adjustments are made by the camera's white balance function so that both the subject and background can be shot with appropriate white balance.

"Canon" logo

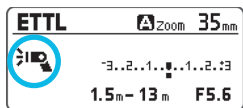
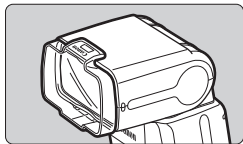
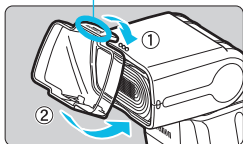

1 Attach the color filter.

- Attach the filter securely to the flash head until it clicks in place, as shown.
- Check that the display changes to .
- To remove the filter, follow the procedure in reverse order. Raise the attachment pins on the lower side of the filter and remove the filter from the flash head.

2 Take the picture.

- Set the camera's white balance to , and take the picture.
- With EOS DIGITAL cameras released in and after 2012, you can also set the white balance to **<AWB>** for shooting (except with EOS REBEL T5/1200D).
- Check the resulting image and perform white balance compensation on the camera as required.



- The flash guide number decreases when you use the color filter. When performing manual flash, compensate flash output, approximately +1 stop.
- Do not use a commercial color filter in combination with the provided color filter.

- With cameras that are not compatible with color temperature information transmission (p.22), take a shot and set it for manual white balance using the color filter in the shooting environment, set the white balance to <☺>, and shoot.
- Attaching the color filter to the flash head does not affect the flash coverage.
- If dirt or dust adheres to the color filter, wipe it off with a soft, dry cloth.
- You can also attach the bounce adapter (p.30) when using the color filter.
- If you want to shoot with the ambience of tungsten-light (warm color cast), set the white balance compensation toward the amber side.

Clearing Speedlite Settings ☆

You can revert the settings of the Speedlite shooting functions and wireless shooting settings to their defaults.

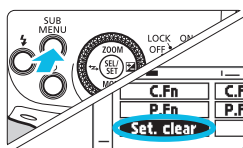

1 Display the Clear Settings screen.

- Press the <SUB MENU> button.
- Turn <⊙> to select <Set. clear>, then press <⊙>.
- ▶ A confirmation screen is displayed.

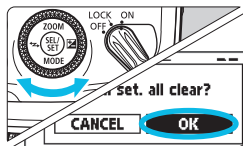

2 Clear the settings.

- Turn <⊙> to select <OK>, then press <⊙>.
- ▶ The Speedlite settings are cleared, and normal shooting and <ETTL> flash mode will be set.

Even when the settings have been cleared, the transmission channel and wireless radio ID during wireless shooting as well as the settings of the Custom Functions (C.Fn) and Personal Functions (P.Fn) will not be cleared.

3

Setting Flash Functions with Camera Operations

This chapter describes how to set the flash functions from the camera's menu screen.

 When the camera's shooting mode is set to a fully automatic mode or a Basic Zone mode, the operations in this chapter are not available. Set the camera's shooting mode to <P>, <Tv>, <Av>, <M>, or (Creative Zone mode).

Flash Control from the Camera's Menu Screen

When using EOS DIGITAL cameras released in and after 2007, you can set flash functions or Custom Functions from the camera's menu screen.

For camera operations, refer to the camera's instruction manual.

Flash Function Settings

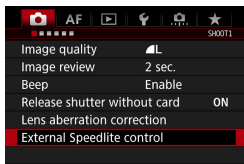

1 Select [External Speedlite control].

- Select [External Speedlite control] or [Flash control].

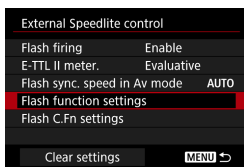

2 Select [Flash function settings].

- Select [Flash function settings] or [External flash func. setting].
- ▶ The setting screen is displayed.

3 Set the function.

- The setting screen and items displayed vary depending on the camera.
- Select an item and set the function.

Example 1

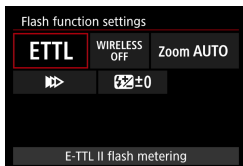

Example 2

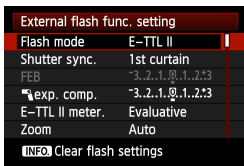

Settings Available on the Flash Function Settings Screen

- **EOS DIGITAL cameras released in and after 2012**

On the camera's **[Flash function settings]** or **[External flash func. setting]** screen, you can configure normal shooting and radio transmission wireless shooting settings.

* Although EOS REBEL T5/1200D was released after 2012, the configurable functions are the same as with EOS DIGITAL cameras released from 2007 to 2011.

- **EOS DIGITAL cameras released from 2007 to 2011**

EOS-1Ds Mark III, EOS-1D Mark IV/III, EOS 5D Mark II, EOS 7D, EOS 60D, EOS 50D, EOS 40D, EOS REBEL T3i/600D, EOS REBEL T2i/550D, EOS REBEL T1i/500D, EOS REBEL XSi/450D, EOS REBEL T3/1100D, EOS REBEL XS/1000D

On the **[Flash function settings]** or **[External flash func. setting]** screen, you can configure normal shooting settings. To use "Radio transmission wireless shooting", set the functions by operating the flash.

The configurable functions are as follows. The settings available vary by the camera used, flash mode, and wireless function settings, etc.

Functions	
Flash firing	Enable / Disable
E-TTL II flash metering	Evaluative / Average
Flash synchronization speed in Av mode	
Flash mode	E-TTL II (autoflash) / Manual flash
Shutter synchronization	1st curtain / 2nd curtain / High-speed
Flash exposure compensation	
Zoom (flash coverage)	
Wireless flash functions	Wireless:Off / Wireless:Radio transmission
Clear settings	

- **Flash firing**

To perform flash shooting, set to **[Enable]**. To use the flash's AF-assist beam only, set to **[Disable]**.

- **E-TTL II flash metering**

For normal exposures, set it to **[Evaluative]**. If **[Average]** is set, the flash exposure will be averaged for the entire scene metered by the camera. Flash exposure compensation may be necessary depending on the scene. This setting is for advanced users.

- **Flash synchronization speed in Av mode**

You can set the flash synchronization speed when shooting in aperture-priority AE (**Av**) mode with flash.

- **Flash mode**

You can select **[E-TTL II]** or **[Manual flash]** according to your shooting objective.

- **Shutter synchronization**

You can select the flash firing timing/method from **[1st curtain]**, **[2nd curtain]**, or **[High-speed synchronization]**. To perform normal flash shooting, set **[1st curtain]**.

- **Flash exposure compensation**

In the same way as normal exposure compensation, you can set exposure compensation for flash. The flash exposure compensation amount can be set up to ± 3 stops in 1/3-stop increments.

- **Zoom (flash coverage)**

You can set the Speedlite flash coverage. When **[Auto]** is selected, the flash coverage is set automatically according to the focal length of the shooting lens and the image sensor size of the camera (p.22).



- **[Flash firing]** and **[E-TTL II flash metering]** are displayed in step 2 or step 3 on page 40. (Display layouts and procedures vary by camera model.)
- When **[Flash sync. speed in Av mode]** is not displayed, it can be set with the camera's Custom Functions.

- **Wireless flash functions**

You can set radio transmission wireless flash shooting. For details, see Chapter 4 (p.45).

- **Clear settings**

You can revert the settings of Speedlite to their default settings.



- When P.Fn-05-0 is set (p.87), AF-assist beam (p.22), which uses a series of small flashes, is emitted as necessary, even if you set **[Flash firing]** to **[Disable]**.
- If the flash coverage is automatically set such as when the bounce adapter is attached or the wide panel is used, setting **[Zoom]** (flash coverage) is not possible.



When the flash exposure compensation is set on the flash, flash exposure compensation cannot be performed from the camera. If both are set at the same time, priority is given to the setting on the flash.

Flash Custom Function Settings

You can set Custom Functions for the Speedlite from the camera's menu screen. The details displayed vary by the camera. If C.Fn-21 to 23 are not displayed, set them by operating the Speedlite. For the Custom Functions, see pages 83-85.

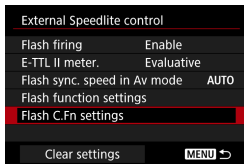

1 Select [Flash C.Fn settings].

- Select [Flash C.Fn settings] or [External flash C.Fn setting].
- ▶ The flash Custom Function settings screen is displayed.

Custom Function number

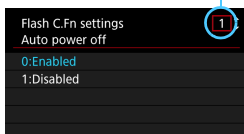

2 Set the Custom Function.

- Select the Custom Function number, then set the function.
- To clear all the Custom Function settings, select ([Clear settings],) [Clear all Speedlite C.Fn's] or [Clear ext. flash C.Fn set.] in step 1.

- When using a camera released in 2011 or earlier, or EOS REBEL T5/1200D, the C.Fn-21 to 23 settings are not cleared even if [Clear all Speedlite C.Fn's] or [Clear ext. flash C.Fn set.] is selected. When the procedure described in "Clearing All the Custom/Personal Functions" on page 82 is performed, all the Custom Functions (except C.Fn-00) are cleared.
- Personal Functions (P.Fn/p.86) cannot be set or all cleared at once from the camera's menu screen. Set them by operating the Speedlite.

4

Wireless Flash Photography: Radio Transmission

This chapter describes wireless flash shooting using the radio transmission wireless sender/receiver function. For the accessories required for radio transmission wireless shooting, see the system map (p.90). For the regions of use, restrictions, and precautions related to radio transmission, see page 103.

- **When using a “Speedlite 430EX III”, which is not equipped with the radio transmission function, shootings described in this chapter are not available.** To shoot with optical transmission wireless flash using the receiver function, see Chapter 5 (p.71).
- When the camera's shooting mode is set to a fully automatic mode or a Basic Zone mode, the operations in this chapter are not available. Set the camera's shooting mode to <P>, <Tv>, <Av>, <M>, or (Creative Zone mode).



- The procedures for wireless flash shooting are described, using the 430EX III-RT for both the sender and receiver unit.
- The 430EX III-RT attached to the camera is called “sender”, and the 430EX III-RT controlled wirelessly is called “receiver”.

(☑) Radio Transmission Wireless Flash Shooting

Using a Canon Speedlite (sender/receiver) equipped with the radio transmission wireless shooting function, you can easily perform wirelessly-controlled shooting with multiple flashes in the same way as normal E-TTL II/E-TTL autoflash shooting.

The system is designed so that the settings of the 430EX III-RT (sender) attached to the camera are automatically applied to the wirelessly controlled 430EX III-RT (receiver). Therefore, you do not need to operate the receiver unit while shooting.

Positioning and Operation Range (Wireless flash shooting examples)

● Autoflash Shooting Using One Receiver Unit (p.55)

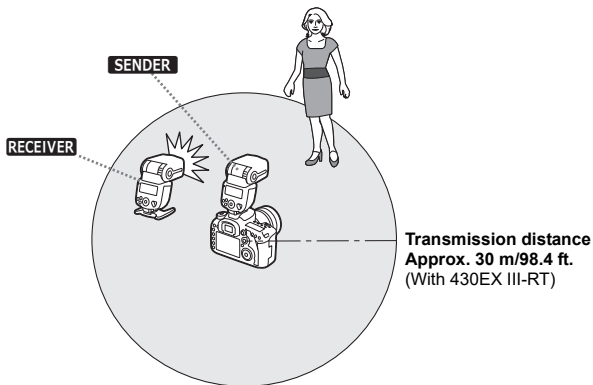

- You can also wirelessly control a 430EX III-RT set as the receiver unit with a device that is equipped with the radio transmission wireless sender function other than a 430EX III-RT. For details on setting the sender unit functions, refer to the instruction manual of the device.
- Position the receiver unit, using the provided mini stand (p.14).

Wireless Multiple Flash Shooting

You can divide the receiver units into two or three groups and perform E-TTL II/E-TTL autoflash shooting while changing the flash ratio (flash output rate).

In addition, you can set and shoot in a different flash mode for each firing group with up to 5 groups (p.48).

● Autoflash Shooting with Receiver Groups

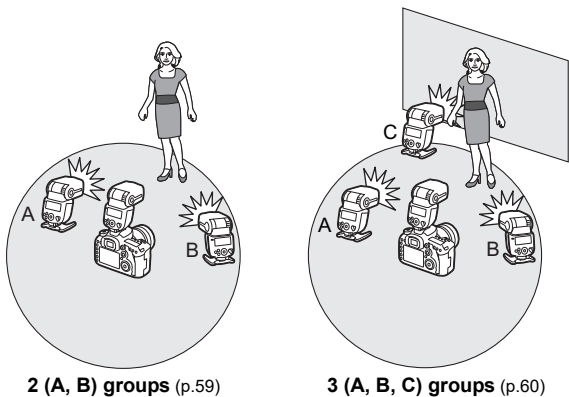

- Before shooting, perform a test flash (p.18) and test shooting.
- The transmission distance may be shorter depending on the conditions such as the positioning of receiver units, the surrounding environment, and weather conditions.

● Shooting in a Different Flash Mode Set for Each Group (p.63)

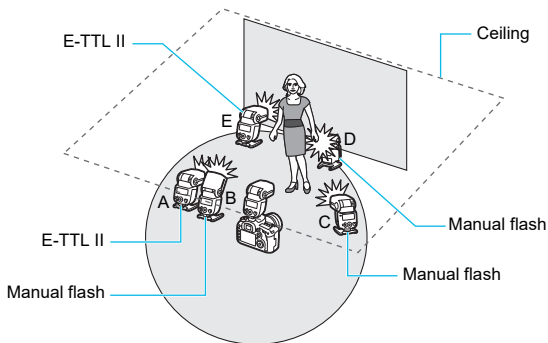

* The flash mode settings are indicated only as an example.

Difference between Radio Transmission and Optical Transmission

Wireless shooting using radio transmission has advantages over wireless shooting using optical transmission, such as being less affected by obstacles, and not having to point the receiver unit's wireless sensor toward the sender unit. The main functional differences are as follows.

Function		Radio Transmission	Optical Transmission
Transmission distance		Approx. 30 m/98.4 ft.	Approx. 15 m/49.2 ft. (indoors)
Firing group control		Up to 5 groups*1 (A, B, C, D, E)	Up to 3 groups (A, B, C)
Receiver unit control		Up to 15 units	No restriction
Channel		Auto, Ch. 1 - 15	Ch. 1 - 4
Wireless radio ID		0000-9999	-
Receiver operations	Test flash firing	○	-
	Modeling flash	○*2	-
	Release	○*3	-

*1-3: Some restrictions apply depending on the camera used.

(See p.49 and 63 for *1, p.65 for *2, and p.66 for *3.)

Restrictions on Functions Depending on the Camera Used

When performing radio transmission wireless flash shooting, function restrictions may apply, depending on the camera used.

● EOS DIGITAL cameras released in and after 2012

When using the flash with a camera such as the EOS-1D X, you can shoot without any restrictions on the flash mode and flash sync speed, etc.

* Although EOS REBEL T5/1200D was released after 2012, restrictions on functions are the same as with EOS DIGITAL cameras released up to 2011. (See the following explanation for details.)

● EOS cameras compatible with E-TTL and released up to 2011

When using the flash with the cameras listed below, radio transmission wireless shooting using E-TTL autofocus is not possible. Shoot with the manual flash (p.62) or optical transmission wireless receiver function (p.71).

EOS-1Ds, EOS-1D, EOS-1V, EOS-3, EOS Elan II/Elan II E/50/50E, EOS REBEL 2000/300, EOS REBEL G/500N, EOS REBEL XS N/REBEL G II/3000N/66, EOS IX, EOS IX Lite/IX7

Also, when using the flash with an EOS DIGITAL camera or EOS film camera released up to 2011, the following restrictions apply.

1. The flash sync speed is 1 stop slower.

Check the flash sync speed ($X = 1/^{***}$ sec.) of your camera and shoot with a shutter speed up to 1 stop slower than the flash sync speed (Example: When $X = 1/250$ sec., radio transmission wireless shooting is possible from $1/125$ sec. to 30 sec.).

When you set the shutter speed 1 stop slower than the flash sync speed, the <Tv> warning icon will disappear.

2. High-speed sync shooting is not possible.

3. Group flash is not possible (p.63).

4. Modeling flash from the receiver unit (p.65) as well as remote release from the receiver unit (p.66) are not possible.

5. The camera cannot be used for a “receiver camera unit” during linked shooting (p.67).

The camera can only be used for a “sender camera unit”.

Wireless Settings

To perform radio transmission wireless shooting, set the sender unit and receiver unit with the following procedure.

Sender Unit Setting

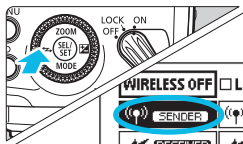

Set to <((P)) **SENDER**>.

- Press the <↔> button of the <⬠> cross keys.
- Turn <⊙> to select <((P)) **SENDER**>, then press <⊙>.

Receiver Unit Setting

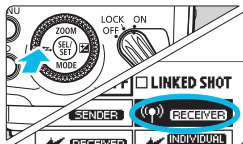

Set to <((P)) **RECEIVER**>.

- Operate and set the flash you want to set as the receiver unit.
- Select <((P)) **RECEIVER**> in the same way as for the sender unit setting.

ⓘ To perform normal flash shooting, select <WIRELESS OFF> to clear the wireless (sender/receiver) settings.

Transmission Channel/Wireless Radio ID Settings

To avoid interference with wireless flash systems using radio transmission used by other photographers or with other devices using radio waves (wireless), you can change the transmission channel and wireless radio ID. **Set the same channel and ID for both the sender unit and receiver unit.**

ⓘ When establishing multiple radio transmission wireless flash systems, interference between flash systems may occur even if the flashes are set to different channels. Set different wireless radio transmission IDs for each channel (p.51).

● Setting the Transmission Channel/Wireless Radio ID

Use the following procedure to set the transmission channels and wireless radio IDs of the sender unit and receiver unit. Set the same channel and ID for both the sender unit and receiver unit. Note that the procedure is the same for the sender unit and receiver unit.

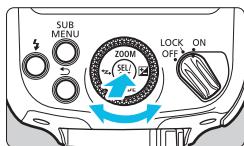

Transmission channel

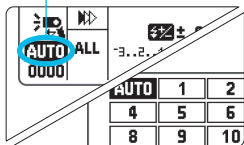

Wireless radio ID

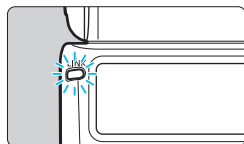
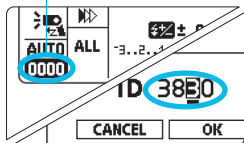

1 Set a channel.

- Press <⊙>.
- Turn <⊙> to select the channel symbol, then press <⊙>.
- Turn <⊙> to select <AUTO> or any channel between Ch. <1> and <15>, then press <⊙>.

2 Set a wireless radio ID.

- Press <⊙>.
 - Turn <⊙> to select the ID symbol, then press <⊙>.
 - Turn <⊙> to select the position (digit) to be set, then press <⊙>.
 - Turn <⊙> to select a number from 0 to 9, then press <⊙>.
 - Set a 4-digit number with the same procedure, and select <OK>.
- ▶ When transmission between the sender unit and receiver unit is established, the <LINK> lamp is lit in green.

● Scanning and Setting the Sender Unit Transmission Channels

You can scan the radio reception status and set the sender unit's transmission channel automatically or manually. When the channel is set to "AUTO", the channel with the best reception signal is set automatically. When setting the channel manually, you can reset the transmission channel while referring to the scan results.

Scanning when "AUTO" is set

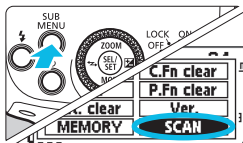

Run the scan.

- Press the < SUB MENU > button.
- Turn < ⓪ > to select < SCAN >, then press < ⓪ >.
- Select < OK >.
- ▶ The scan is performed, and the channel with the best reception signal is set.

Scanning when a channel between Ch. 1 and 15 is set

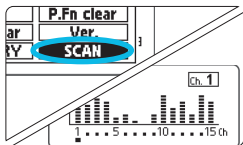

1 Run the scan.

- Press the < SUB MENU > button.
- Turn < ⓪ > to select < SCAN >, then press < ⓪ >.
- Select < OK >.
- ▶ The scan is performed and the reception status is displayed in a graph.
- The higher the peak of the channel in the graph, the better the radio reception signal.

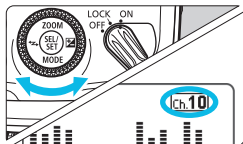

2 Set a channel.

- Turn < ⓪ > to select a channel from Ch. 1 to 15.
- Press < ⓪ > to set the channel.

The <LINK> Lamp

You can check the transmission status by viewing the color of the <LINK> lamp.

Color	Status	Description	Action
Green	Lit	Transmission OK	—
Red	Lit	Not connected	Check the channel and ID.
	Blinking	Too many units	Change the sender and receiver unit total to 16 or less.
		Error	Turn the sender unit and receiver unit off and on again.



- If the transmission channels of the sender unit and receiver unit are different, the receiver unit will not fire. Set both to the same number or set both to “AUTO”.
- If the wireless radio IDs of the sender unit and receiver unit are different, the receiver unit does not fire. Set to the same number.

Sender Flash Firing ON/OFF

You can set whether or not to fire the sender unit as a wireless flash that controls the receiver unit. When sender flash firing is set to ON, the sender unit is fired as firing group A.

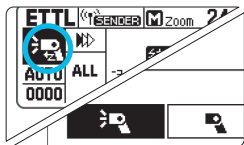
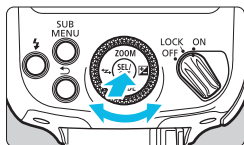

Set sender flash firing to ON or OFF.

- Press <SEL>.
- Turn <LOCK ON> to select the flash firing symbol, then press <SEL>.
- Turn <LOCK ON> to select sender flash firing ON or OFF, then press <SEL>.
 - ☑ : Sender flash firing ON
 - ☒ : Sender flash firing OFF

LCD Panel Illumination

During radio transmission wireless shooting, the sender unit's LCD panel illuminates or turns off according to the charge status of the sender unit and receiver units (firing groups). The sender unit's LCD panel illuminates if the sender unit and receiver units are not fully charged. When the sender unit and receiver units are fully charged, the LCD panel illumination will turn off after approx. 12 sec. As the charge for the sender unit and receiver units becomes insufficient when you take a picture, the sender unit's LCD panel will be illuminated again.

 If any of the sender unit or receiver unit (firing group) is not fully charged, **< CHARGE >** will be displayed on the sender unit's LCD panel. Make sure to take the picture after checking either the **< CHARGE >** icon is not displayed on the LCD panel or the LCD panel is not illuminated.

Memory Function

You can save the wireless settings to the sender unit and receiver unit, and recall the settings later. Operate the sender unit or receiver unit separately depending on which unit's settings are to be saved or recalled.

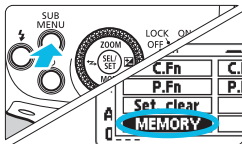

1 Select **<MEMORY>**.

- Press the **< SUB MENU >** button.
- Turn **< ⓪ >** to select **<MEMORY>**, then press **< ⓪ >**.

2 Save or load the settings.

- Turn **< ⓪ >** to select **< SAVE >** (save) or **< LOAD >** (load), then press **< ⓪ >**.
- Select **< OK >**.
- ▶ The settings are saved (stored in the memory) or the settings that were saved are set.



ETTL: Fully Automatic Wireless Flash Shooting

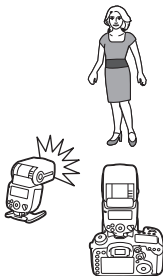

This section describes the basic fully automatic wireless shooting when using a 430EX III-RT attached to the camera (sender) and a 430EX III-RT set as a receiver unit.

Autoflash Shooting Using One Receiver Unit



1 Set the sender unit.

- Set the 430EX III-RT attached to the camera as the sender unit (p.50).
- You can also use a device equipped with the radio transmission wireless sender function as the sender unit.



Firing group

2 Set the receiver unit.

- Set the 430EX III-RT to be controlled wirelessly from the sender as the receiver unit (p.50).
- Set the firing group to A, B, or C (p.59). The flash will not fire if it is set to D or E.

3 Check the channel and ID.

- If the transmission channels and wireless radio IDs of the sender unit and receiver unit are different, set them to the same settings (p.51, 52).

4 Position the camera and the flash.

- Position them within the range shown on page 46.

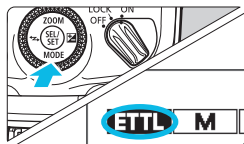

5 Set the flash mode to <ETTL>.

- Press the <MODE> button of the <⬆️⬇️⬇️⬆️> cross keys of the sender unit.
- Turn <⌚> to select <ETTL>, then press <⌚>.
- The receiver unit is set automatically to <ETTL> during shooting via the control from the sender unit.
- Check that the firing group control is set to <ALL>.

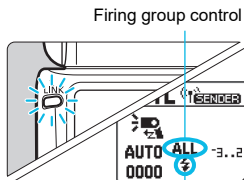

Firing group control

6 Check the transmission status and charge status.

- Check that the <LINK> lamp is lit in green.
- When the receiver flash is ready, the AF-assist beam emitter blinks at approx. 1-second intervals.
- Check that the <⚡> receiver flash-ready icon is lit on the sender unit's LCD panel (<CHARGE> is not displayed).
- For the sender unit's LCD panel illumination, see page 54.
- Check that the sender unit's flash-ready lamp is lit.

Receiver flash ready

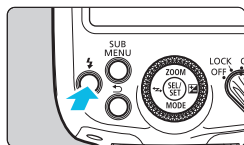
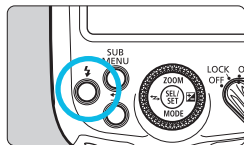

7 Check the performance.

- Press the sender unit's test flash button.
- ▶ The receiver unit fires. If it does not fire, check that it is placed within the transmission range (p.46).

8 Take the picture.

- Set the camera and take the picture in the same way as with normal flash shooting.

Autoflash Shooting Using Multiple Receiver Units

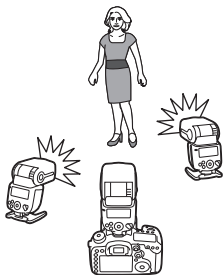

When you need more flash output or you want to perform lighting more easily, you can increase the number of receiver units and fire them as a single flash.

To add receiver units, perform the same procedure as “Autoflash Shooting Using One Receiver Unit” (p.55). Set the firing group to A, B, or C (p.59). The flash will not fire if it is set to D or E.

When the number of receiver units is increased or sender flash firing is set to ON, automatic control is performed to fire all flashes at the same flash output and to ensure that the total flash output results in the standard exposure.



- If any of the sender unit or receiver unit (firing group) is not fully charged, **<CHARGE>** will be displayed on the sender unit's LCD panel. Make sure to take the picture after checking the **<CHARGE>** icon is not displayed.
- If the **<LINK>** lamp is red, radio transmission has not been established. Check the transmission channels and wireless radio IDs of the sender unit and receiver unit again. If you cannot connect with the same settings, turn the sender unit and receiver unit off and on again.



- The sender/receiver flash coverage is set to 24 mm. You can also set the flash coverage manually.
- To also fire the sender unit, set the sender flash firing to ON in step 5 (p.53).
- You can press the depth-of-field preview button on the camera to fire the modeling flash (p.36).
- When a Speedlite is set as the sender unit, the time until auto power off takes effect is approx. 5 min.
- If a receiver unit's auto power off takes effect, press the sender unit's test flash button (p.56) to turn on the receiver unit. Note that the test flash cannot be performed while the camera's timer is operating.

Advanced Shooting with Fully Automatic Wireless Flash

Flash exposure compensation and other settings set on the sender unit will be set automatically on the receiver unit(s). You do not need to operate the receiver unit(s). Wireless flash shooting with the following settings can be performed in the same way as in normal flash shooting.

- **Flash exposure compensation** (Fn/p.24)
- **High-speed sync** (Fn/p.26)
- **FE lock** (p.25)
- **Manual flash** (p.34, 62)



- You can also directly operate the receiver unit to separately set flash exposure compensation and flash coverage on each receiver unit.
- You can also perform FEB shooting and stroboscopic flash using the 430EX III-RT set as a receiver unit with a sender unit equipped with FEB and stroboscopic flash functions.

Sender Units

You can use two or more sender units (sender units + receiver units = maximum of 16 units). By preparing multiple cameras with sender units attached, you can perform wireless flash shooting by changing cameras while keeping the same lighting (receiver units).

Note that when using two or more sender units, the color of the <LINK> lamp varies depending on the order in which the power was turned on. The first sender (main sender) is green, and the second and subsequent senders (sub-senders) are orange.



If the <LINK> lamp is red, the connection has not been established. After checking the transmission channel and wireless radio ID, turn each sender unit off and on again.



You can take pictures regardless of the main sender and sub sender status.

A:B: Wireless Multiple Flash Shooting with Flash Ratio

Autoflash Shooting with Two Receiver Groups

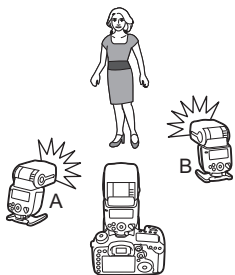

You can divide the receiver units into two firing groups, A and B, and adjust the lighting balance (flash ratio) for shooting. The exposure is controlled automatically so that the total flash output of firing groups A and B results in the standard exposure.

Firing groups

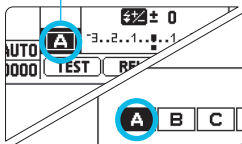

1 Set the firing group of the receiver units.

- Operate and set the receiver units one by one.
- Press $\langle \odot \rangle$.
- Turn $\langle \odot \rangle$ to select the firing group symbol, then press $\langle \odot \rangle$.
- Turn $\langle \odot \rangle$ to select $\langle \mathbf{A} \rangle$ or $\langle \mathbf{B} \rangle$, then press $\langle \odot \rangle$.
- Set one unit to $\langle \mathbf{A} \rangle$, and the other unit to $\langle \mathbf{B} \rangle$.

Firing group control

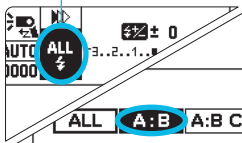

2 Set the sender unit to $\langle \mathbf{A:B} \rangle$.

- The procedures in steps 2 to 3 are to be set on the sender unit.
- Press $\langle \odot \rangle$.
- Turn $\langle \odot \rangle$ to select the firing group control symbol, then press $\langle \odot \rangle$.
- Turn $\langle \odot \rangle$ to select $\langle \mathbf{A:B} \rangle$, then press $\langle \odot \rangle$.

A:B flash ratio

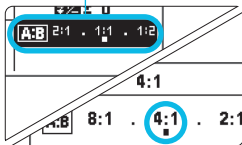

3 Set the A:B flash ratio.

- Turn $\langle \odot \rangle$ to select the A:B flash ratio symbol, then press $\langle \odot \rangle$.
- Turn $\langle \odot \rangle$ to set the flash ratio, then press $\langle \odot \rangle$.

4 Take the picture.

- ▶ The receiver units fire at the set flash ratio.

Autoflash Shooting with Three Receiver Groups

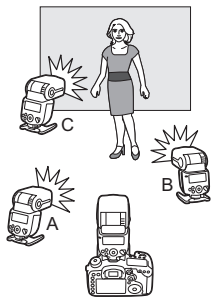

You can add firing group C to firing groups A and B. C is convenient to set lighting so as to eliminate the subject's shadow.

The basic setting procedure is the same as "Autoflash Shooting with Two Receiver Groups".

1 Set the receiver unit to firing group C.

- Set the receiver unit you want to add to flash firing group $\langle \mathbf{C} \rangle$ in the same way as step 1 on the preceding page.

2 Set the sender unit to $\langle \mathbf{A:B C} \rangle$.

- Set sender firing group control to $\langle \mathbf{A:B C} \rangle$ in the same way as step 2 on the preceding page.

3 Set the A:B flash ratio.

- Set the A:B flash ratio in the same way as step 3 above.



Receiver C flash exposure compensation amount

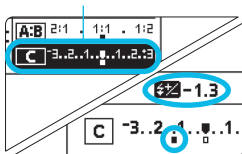

4 Set the flash exposure compensation amount for receiver C.

- Set it by operating the sender.
- Set the amount as necessary.
- Press $\langle \odot \rangle$.
- Turn $\langle \odot \rangle$ to select the flash exposure compensation amount symbol for C, then press $\langle \odot \rangle$.
- Turn $\langle \odot \rangle$ to set the flash exposure compensation amount, then press $\langle \odot \rangle$.

Group Control

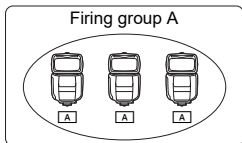

If you need more flash output or wish to perform more sophisticated lighting, you can increase the number of receiver units. Simply set an additional receiver unit to the firing group (A, B, or C) whose flash output you want to increase. You can increase the number of receiver units up to 15 units in total.

For example, if you set a firing group with three receiver units to $\langle \blacksquare A \rangle$, the three units are treated and controlled as a single firing group A with a large flash output.



- To fire the three firing groups A, B, and C at the same time, set $\langle \blacksquare A:B \rangle$. With the $\langle \blacksquare A:B \rangle$ setting, firing group C does not fire.
- If you shoot with firing group C pointing directly toward the main subject, overexposure may result.



The flash ratio of 8:1 to 1:1 to 1:8 is equivalent to 3:1 to 1:1 to 1:3 (1/2-stop increments) when converted to the number of stops.

M: Wireless Multiple Flash Shooting with Manual Output

This section describes wireless (multiple flash) shooting using manual flash. You can shoot with a different flash output setting for each receiver unit (firing group). Configure all the settings on the sender unit.



1 Set the flash mode to <M>.

- Press the <MODE> button of the <◀▶> cross keys of the sender unit.
- Turn <⊙> to select <M>, then press <⊙>.

Firing group control

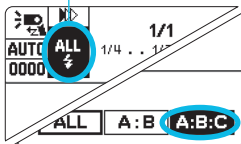

2 Set firing group control.

- Press <⊙>.
- Turn <⊙> to select the firing group control symbol, then press <⊙>.
- Turn <⊙> to select the group to be fired, then press <⊙>.

- <ALL> : Set all groups to the same flash output
- <A:B> : Set the flash output of A and B
- <A:B:C> : Set the flash output of A, B, and C

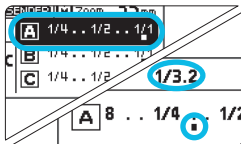

3 Set the flash output.

- Turn <⊙> to select the firing group symbol, then press <⊙>.
- Turn <⊙> to set the flash output, then press <⊙>.
- With <A:B> and <A:B:C>, repeat steps 3 to set the flash output for all groups.

4 Take the picture.

- ▶ Each group fires at the set flash ratio.

⚠ When <ALL> is set, set A, B, or C as the firing group for the receiver units (p.59). The flash will not fire if it is set to D or E.

Gr: Shooting in a Different Flash Mode for Each Group

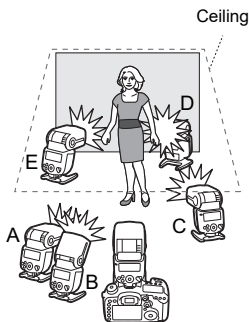

When using an EOS DIGITAL camera released in and after 2012, such as the EOS-1D X, you can shoot in a different flash mode set for each firing group with up to 5 groups (A, B, C, D, and E).

The flash modes that can be set are ① E-TTL II/E-TTL autoflash, ② Manual flash, and ③ Auto external flash metering. When the flash mode is ① or ③, exposure is controlled to result in standard exposure for the main subject as a single group.

This function is for advanced users who are very knowledgeable and experienced in lighting.

Wireless flash shooting using the <Gr> flash mode cannot be performed with cameras released up to 2011 or EOS REBEL T5/1200D. Shooting with up to 3 groups (A, B and C) will be applied (p.60).

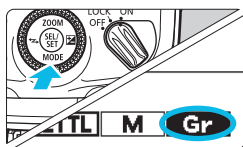

1 Set the flash mode to <Gr>.

- Press the <MODE> button of the <◇> cross keys of the sender unit.
- Turn <⊙> to select <Gr>, then press <⊙>.

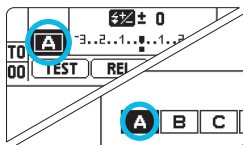

2 Set the firing group of the receiver units.

- Operate and set the receiver units one by one.
- Press <⊙>.
- Turn <⊙> to select the firing group symbol, then press <⊙>.
- Turn <⊙> to select <A>, , <C>, <D>, or <E>, then press <⊙>.
- Set the firing group (A, B, C, D, or E) for all the receiver units.

Flash exposure compensation for all firing groups

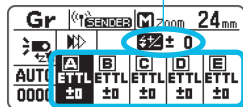

Firing groups

Flash mode

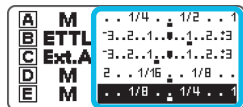
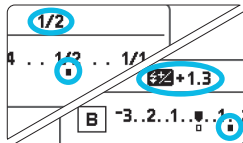
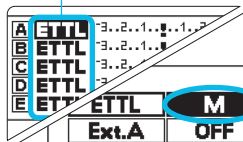

Flash output / flash exposure compensation amount

3 Set each firing group.

- Set the flash mode, flash output, or flash exposure compensation amount of each firing group by operating the sender unit.
- Press $\langle \odot \rangle$.
- Turn $\langle \odot \rangle$ to select the firing group to be set, then press $\langle \odot \rangle$.

Setting the flash mode

- Turn $\langle \odot \rangle$ to select the flash mode displayed on the right of $\langle A \rangle$ to $\langle E \rangle$, then press $\langle \odot \rangle$.
- Turn $\langle \odot \rangle$ to select the flash mode, then press $\langle \odot \rangle$.

Setting the flash output and flash exposure compensation amount

- Turn $\langle \odot \rangle$ to select the flash output or flash exposure compensation amount symbol, then press $\langle \odot \rangle$.
- When using the $\langle M \rangle$ mode, set the flash output. When using the $\langle ETTL \rangle$ or $\langle Ext.A \rangle$ mode (auto external flash metering), set the flash exposure compensation amount as required.
- Repeat step 3 to set the flash function of all firing groups.
- Once the settings are complete, press the $\langle \curvearrowright \rangle$ button to return to the screen of step 3.
- You can set the flash exposure compensation for the entire firing group by selecting the flash exposure compensation $\langle \boxplus \rangle$ symbol, using the screen of step 3.

4 Take the picture.

- ▶ Each receiver unit fires at the same time in each flash mode set.



- While the flash mode can be set to **<Ext.A>** auto external flash metering when 430EX III-RT is set as a sender unit, this function is effective when using a receiver unit that supports **<Ext.A>** (example: 600EX-RT).
- 430EX III-RT does not support **<Ext.A>**. As a result, when the flash mode of the sender unit is set to **<Ext.A>**, 430EX III-RT units set as the receivers do not fire. When using 430EX III-RT as a receiver and setting the flash mode with the sender, do not set the flash mode to **<Ext.A>**.
- When 430EX III-RT is set as the sender unit and the flash mode of firing group "A" is set to **<Ext.A>**, sender flash firing is not performed even if 430EX III-RT is set to "Sender flash firing: ON" (p.53).
- When the flash mode is set to **<ETTL>** or **<Ext.A>**, exposure is controlled as a single group to obtain the standard exposure for the main subject. If you shoot with multiple firing groups pointing toward the main subject, overexposure may result.



- For **<Ext.A>**, refer to the instruction manual of a Speedlite compatible with auto external flash metering.
- When you do not want a certain group to fire, select **<OFF>** when setting the flash mode in step 3.
- The order of firing among firing groups does not need to be consecutive; for example, A, C, E can be set.
- You can set the flash output or flash exposure compensation amount by simply pressing **<⊙>**, selecting the firing group using the **<⬅>** cross keys, and turning **<⊙>** (P.Fn-08/p.88).

Test Flash and Modeling Flash with a Receiver Unit

In radio transmission wireless shooting, you can fire the test flash and modeling flash (p.36) from a 430EX III-RT set as a receiver unit.

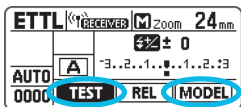

Select **<TEST>** or **<MODEL>**.

- Press **<⊙>** of the receiver unit.
- Turn **<⊙>** to select **<TEST>** or **<MODEL>**, then press **<⊙>**.
- ▶ A flash signal is sent from the receiver unit to the sender unit, and a wireless system test flash or modeling flash is fired.

- Modeling flash is not possible from a receiver unit with cameras released up to 2011 or EOS REBEL T5/1200D.
- For the precautions related to modeling flash, see page 36.
- When C.Fn-02-1 is set on the sender unit, modeling flash will not be fired even if you select < **MODEL** >.



 When there are two or more sender units (p.58), the flash signal is sent to the main sender that has the < **LINK** > lamp lit in green.

Remote Release from a Receiver Unit

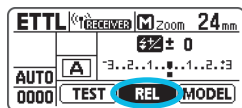
When using an EOS DIGITAL camera released in and after 2012, such as EOS-1D X, you can perform remote release (remote control shooting) from a 430EX III-RT set as a receiver unit during radio transmission wireless shooting.



Select < **REL** >.

- Press <  > of the receiver unit.
- Turn <  > to select < **REL** >, then press <  >.
- ▶ A release signal is sent from the receiver unit to the sender unit, and the picture is taken.

- Remote release is not possible from a receiver unit with cameras released up to 2011 or EOS REBEL T5/1200D.
- Shooting is not possible when autofocus fails. It is recommended that you set the focus mode switch of the lens to < **MF** >, manually focus on the subject, then release.

 Remote release is performed with “Single shooting” regardless of the camera’s drive mode setting.

- When there are two or more sender units (p.58), the release signal is sent to the main sender that has the < **LINK** > lamp lit in green.

Linked Shooting with Radio Transmission

When using an EOS DIGITAL camera released in and after 2012 (except EOS REBEL T5/1200D), such as EOS-1D X, you can perform linked shooting, which automatically releases the shutter of a receiver camera unit by linking it to the sender camera unit. You can perform linked shooting with up to 16 units, including both sender units and receiver units. This is convenient when you want to shoot a subject from multiple angles at the same time.

To perform linked shooting, attach a Speedlite or a Speedlite Transmitter that supports radio transmission wireless shooting to the camera.

Note that when used with a camera released up to 2011 or EOS REBEL T5/1200D, the unit can be used only as a “sender camera unit”. The unit cannot be used as a “receiver camera unit”.

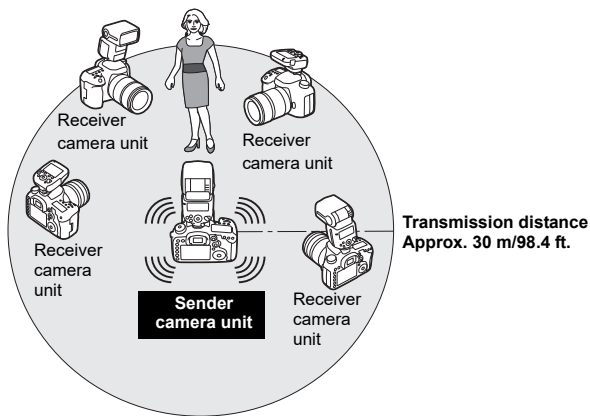

Before performing the operations on the next page, attach a Speedlite or transmitter to all the cameras to be used for linked shooting. For details on setting other devices, refer to the instruction manuals of the devices.

 The combination of an EOS camera and 430EX III-RT set with linked shooting function is called either “sender camera unit” or “receiver camera unit”.

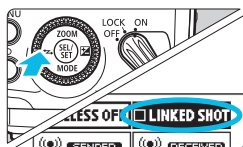

1 Set to linked shooting mode.

- Press the <↔> button of the <⬆> cross keys.
- Turn <⊙> to select < LINKED SHOT >, then press <⊙>.

▶ The display changes to < LINKED SHOT >.



2 Set the sender/receiver unit.

- Turn <⊙> to select < SENDER > or < RECEIVER >, then press <⊙>.

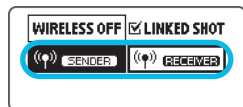

3 Set the transmission channel and wireless radio ID.

- For details on the setting procedure, see pages 50 to 53.

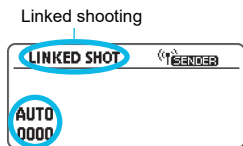

Transmission channel/
Wireless radio ID

4 Set the camera's shooting functions.

5 Set all the Speedlites.

- Set all the Speedlites to perform linked shooting to "sender unit" or "receiver unit" in linked shooting.
- Set the transmitters in the same way if any to be used in linked shooting.

- When changing the setting from “receiver unit” to “sender unit” in step 2, other Speedlites (or transmitters) that were set as “sender unit” until then automatically switch to “receiver unit”.

6 Set up the receiver camera units.

- Set up all the receiver camera units within approximately 30 m/98.4 ft. of the sender camera unit.
- Check that the <LINK> lamps of the receiver units are lit in green.

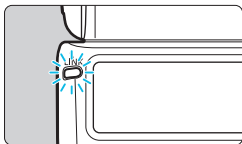

7 Take the picture.

- Check that the <LINK> lamp of the sender unit is lit in green and take the picture.
 - ▶ The receiver camera units are released linked with release of the sender camera unit.
 - ▶ After shooting with linked shooting, the <LINK> lamps of the receiver units are briefly lit in orange.



- When you want to clear linked shooting, operate the Speedlites one by one to change the setting to <□ LINKED SHOT> in step 1.
- You can use this function as a remote control for linked shooting without attaching a Speedlite to a camera. Press <⊙> of the sender unit and select <■ REL ■> to release all receiver camera units.
- During linked shooting, the time until auto power off takes effect is approx. 5 min. for both the sender and the receiver units. Note that when the interval of linked shooting is 5 min. or longer, set the “Auto power off” to “OFF” on both the sender and the receiver units (C.Fn-01-1, p.83).

- Setting the focus mode switches of the lenses attached to the receiver cameras to **<MF>** and taking the picture with manual focusing is recommended. If focus cannot be achieved with autofocus, linked shooting is not possible with the corresponding receiver camera units.
- There is a short time lag between the release of the receiver camera units and the release timing of the sender camera unit. Perfectly simultaneous shooting is not possible.
- You can fire the Speedlite during linked shooting when P.Fn-07-1 is set (p.88), but the appropriate exposure may not be obtained or uneven exposure may result if you fire multiple Speedlites at the same time during linked shooting.
- When **[Flash firing]** in **[External Speedlite control]** or **[Flash control]** is set to **[Disabled]** (p.42), linked shooting cannot be performed.
- When performing linked shooting with a Live View image displayed and P.Fn-07-0 set (p.88), set **[Silent LV shoot.]** on the sender camera unit menu to **[Disabled]**. If **[Mode 1]** or **[Mode 2]** is set, the receiver camera units will not be released.
- The transmission distance may be shorter depending on the conditions such as the positioning of receiver flashes, the surrounding environment, and weather conditions.
- The linked shooting function is the similar function as the linked shooting featured by the WFT series of wireless file transmitters. However, linked shooting cannot be performed in combination with the WFT series. Moreover, the release time lag differs from linked shooting performed using the WFT series.

● **Linked Shooting Using Live View Function**

Linked shooting in Live View status is not possible when the Speedlite set to P.Fn-07-0 is attached to one of the cameras below set as the sender camera unit.

Perform linked shooting after switching Live View shooting to viewfinder shooting or set the Speedlite to P.Fn-07-1.

EOS REBEL T6S/760D, EOS REBEL T6i/750D, EOS REBEL T5i/700D,
EOS REBEL T4i/650D, EOS REBEL T3i/600D, EOS REBEL T2i/550D,
EOS REBEL T1i/500D, EOS REBEL XSi/450D, EOS REBEL XS/1000D

5

Wireless Flash Photography: Optical Transmission

This chapter describes wireless flash shooting using the optical transmission wireless receiver function. For the accessories required for optical transmission wireless shooting, see the system map (p.90).

 When the camera's shooting mode is set to a fully automatic mode or a Basic Zone mode, the operations in this chapter are not available. Set the camera's shooting mode to <P>, <Tv>, <Av>, <M>, or (Creative Zone mode).

- 
- The optical transmission wireless receiver function is available with both Speedlite 430EX III-RT and Speedlite 430EX III.
 - You can wirelessly control a 430EX III-RT/430EX III set as an optical transmission wireless receiver unit using a device equipped with the optical transmission wireless sender function (p.91).
 - The device equipped with the optical transmission wireless sender function is called the “sender”, and a 430EX III-RT/430EX III that is controlled wirelessly is called a “receiver”.

Optical Transmission Wireless Flash Shooting

Using a Canon device with an optical transmission wireless sender function and 430EX III-RT/430EX III set as a receiver unit makes it easy to shoot with wireless multiple flash lighting in the same way as normal E-TTL II/E-TTL autoflash shooting.

The system is designed so that the settings of the sender unit are set automatically on the 430EX III-RT/430EX III (receiver) that is wirelessly controlled. Therefore, you do not need to operate the receiver unit during shooting (except when set as the individual receiver, p.78).

For details on how to perform optical transmission wireless flash shooting, refer to the instruction manual of the device equipped with the sender function.

Positioning and Operation Range (Wireless flash shooting examples)

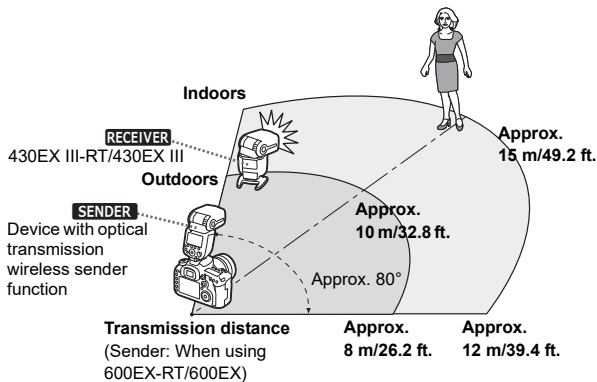

- To avoid interfering with transmission, do not place any obstacles between the sender unit and receiver unit.
- The transmission distance differs according to the sender unit used. Refer to the instruction manual of the sender unit.
- Before shooting, perform a test flash (p.18) and test shooting.

 Position the receiver unit, using the provided mini stand (p.14).



- Turn transmission wireless sensor (p.10) of the receiver unit toward the sender, using the bounce function (p.28).
- When shooting indoors, since the transmission signal is reflected off the walls, operation may be possible even with slightly imprecise positioning.

Wireless Settings

To perform flash shooting using the optical transmission wireless receiver function, configure the settings as follows.

Receiver Unit Setting

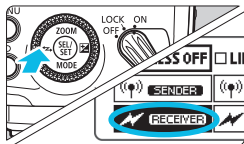

Set to <⚡ **RECEIVER**>.

- Operate and set the flash you want to set as the receiver unit.
- Press the <⚡> button of the <⬆> cross keys.
- Turn <⊙> to select <⚡ **RECEIVER**>, then press <⊙>.



To perform normal flash shooting, select <**WIRELESS OFF**> to clear the wireless (receiver) settings.

Transmission Channel Setting

To avoid interference with optical transmission wireless flash systems used by other photographers, you can change the transmission channel. **Set the same channel for both the sender unit and receiver unit.**

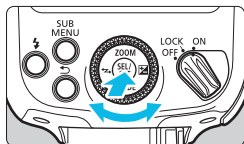

Set a channel.

- Press <⊙>.
- Turn <⊙> to select the channel symbol, then press <⊙>.

Transmission channel

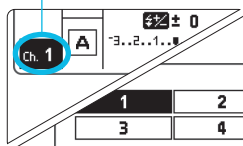

- Turn <⊙> to select any channel between Ch. “1” and “4”, then press <⊙>.

⚠ If the transmission channels of the sender unit and receiver unit are different, the receiver unit will not fire. Set to the same number.

Memory Function

You can save the wireless settings to the receiver unit, and recall the settings later. Operate each receiver unit individually as you desire to save or recall its settings.

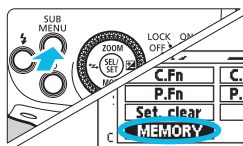

1 Select <MEMORY>.

- Press the <SUB MENU> button.
- Turn <⊙> to select <MEMORY>, then press <⊙>.



2 Save or load the settings.

- Turn <⊙> to select <SAVE> (save) or <LOAD> (load), then press <⊙>.
- Select <OK>.
- ▶ The settings are saved (stored in the memory) or the settings that were saved are set.

ETTL: Fully Automatic Wireless Flash Shooting

This section describes basic fully automatic wireless shooting when using a device (sender) equipped with the optical transmission wireless sender function and a 430EX III-RT/430EX III set as a receiver unit. For details on optical transmission wireless flash shooting and sender unit operation procedure, refer to the instruction manual of the sender device.



1 Set the sender unit.

- Set the device with the sender function as the optical transmission wireless sender unit.

2 Set the receiver unit.

- Set the 430EX III-RT/430EX III to be controlled wirelessly from the sender unit as the receiver unit (p.73).
- A, B, or C can be set as the firing group.

3 Set a channel.

- If the channels of the sender unit and receiver unit are different, set them to the same number (p.73).

4 Position the camera and the flash.

- Position them within the range shown on page 72.

5 Set the flash mode to <ETTL>.

- Set the flash mode of the sender unit to <ETTL>.
- The receiver unit is set automatically to <ETTL> during shooting by control from the sender unit.
- Check that the firing group control is set to <ALL> (no flash ratio control is set: **RATIO OFF**).



6 Check that the flash is ready.

- When the receiver flash is ready, the AF-assist beam emitter blinks with approx. 1-second intervals.
- Check that the sender unit's flash-ready lamp is lit.

7 Check the performance.

- Fire a test flash from the sender unit.
- ▶ The receiver unit fires. If it does not fire, check that it is placed within the transmission range (p.72).

8 Take the picture.

- Set the camera and take the picture in the same way as with normal flash shooting.

 If there is a fluorescent light or computer monitor near a receiver unit, the presence of the light source may cause the receiver unit to malfunction and fire inadvertently.

- 
- The receiver flash coverage is set to 24 mm. You can also set the flash coverage manually.
 - If the receiver unit's auto power off takes effect, press the sender unit's test flash button to turn on the receiver unit.

Advanced Shooting with Fully Automatic Wireless Flash

Since flash exposure compensation and other settings set on the sender unit will be set automatically on the receiver unit(s), you do not need to operate the receiver unit. Wireless flash shooting with the following settings can be performed in the same way as in normal flash shooting.

- **Flash exposure compensation** (Fn/p.24)
- **High-speed sync** (Fn/p.26)
- **FE lock** (p.25)
- **Manual flash** (p.34, 78)



- You can also directly operate the receiver unit to separately set flash exposure compensation and flash coverage on each receiver unit.
- You can also perform FEB shooting and stroboscopic flash using the 430EX III-RT/430EX III set as a receiver unit when the sender is equipped with FEB and stroboscopic flash functions.

Setting the Firing Group

Set the firing group when performing two-group (A, B) or three-group (A, B, C) shooting using 430EX III-RT/430EX III set as the receiver units.

Firing group

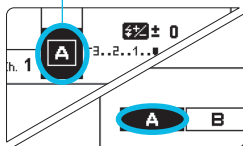

Set the firing group of the receiver units.

- Operate and set the receiver units one by one.
- Press <Fn>.
- Turn <Fn> to select the firing group symbol, then press <Fn>.
- Turn <Fn> to select <A>, , or <C>, then press <Fn>.

You can directly operate the receiver unit to manually set the flash output. This function is called individual receiver. This is convenient when, for example, you use the Speedlite Transmitter ST-E2 (sold separately) to perform wireless manual flash.

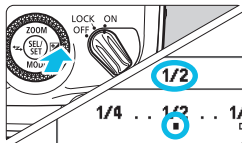
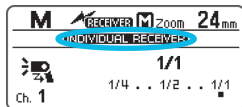
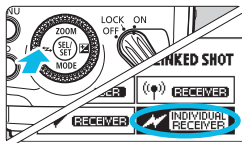

1 Set the individual receiver.

- Press the <↔> button of the <⬠> cross keys.
- Turn <⦿> to select <⚡ INDIVIDUAL RECEIVER >, then press <⦿>.
- ▶ <INDIVIDUAL RECEIVER > appears on the LCD panel.
- ▶ The flash mode is set to <M>.

2 Set the flash output.

- Press the <⏏> button of the <⬠> cross keys.
- Turn <⦿> to set the flash output, then press <⦿>.

 A receiver unit that is set as an individual receiver cannot receive flash mode control from the sender unit. The unit is always fired at the manually set flash output.

6

Customizing the Speedlite

This chapter describes how to customize the Speedlite with the Custom Functions (C.Fn) and Personal Functions (P.Fn).



When the camera's shooting mode is set to a fully automatic mode or a Basic Zone mode, the operations in this chapter are not available. Set the camera's shooting mode to **<P>**, **<Tv>**, **<Av>**, **<M>**, or **** (Creative Zone mode).

C.Fn / P.Fn: Setting Custom and Personal Functions

You can customize the Speedlite features to suit your shooting preferences. The functions used to do this are called the Custom Functions and Personal functions. The Personal Functions are customizable functions unique to the 430EX III-RT/430EX III.

C.Fn: Custom Functions

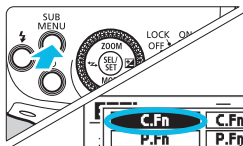

1 Display the Custom Functions screen.

- Press the $\langle \text{SUB MENU} \rangle$ button.
- Turn $\langle \text{ZOOM SEL/SET} \rangle$ to select $\langle \text{C.Fn} \rangle$, then press $\langle \text{ZOOM SEL/SET} \rangle$.
- ▶ The Custom Functions screen is displayed.

2 Select an item to set.

- Turn $\langle \text{ZOOM SEL/SET} \rangle$ to select an item (number) to set.

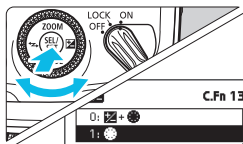

3 Change the setting.

- Press $\langle \text{ZOOM SEL/SET} \rangle$.
- ▶ The setting is displayed.
- Turn $\langle \text{ZOOM SEL/SET} \rangle$ to select the desired setting, then press $\langle \text{ZOOM SEL/SET} \rangle$.
- Press the $\langle \text{LEFT} \rangle$ button to apply the setting.

P.Fn: Personal Functions

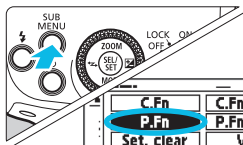











1 Display the Personal Functions screen.

- Select $\langle \text{P.Fn} \rangle$ and press $\langle \text{ZOOM SEL/SET} \rangle$ in the same way as step 1 for the Custom Functions.
- ▶ The Personal Functions screen is displayed.









2 Set the function.

- Set the Personal Functions in the same way as steps 2 and 3 for the Custom Functions.

Custom Function List

Number	Function		Page
C.Fn-00		Distance indicator display	p.83
C.Fn-01		Auto power off	
C.Fn-02	 MODELING	Modeling flash	
C.Fn-08		AF-assist beam firing	p.84
C.Fn-10		Receiver auto power off timer	
C.Fn-11		Receiver auto power off cancel	
C.Fn-13		Flash exposure compensation setting	
C.Fn-21		Light distribution	p.85
C.Fn-22		LCD panel illumination	
C.Fn-23		Receiver flash charge check	

Personal Function List

Number	Function		Page
P.Fn-01		LCD panel display contrast	p.86
P.Fn-02		LCD panel illumination color: Normal shooting	
P.Fn-03		LCD panel illumination color: Sender	
P.Fn-04		LCD panel illumination color: Receiver	
P.Fn-05		AF-assist beam emission method	p.87
P.Fn-06		Quick flash	
P.Fn-07		Flash firing during linked shooting	p.88
P.Fn-08		Dial setting changes	

Clearing All the Custom/Personal Functions

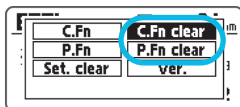

You can clear all Custom Functions or Personal Functions by selecting < **C.Fn clear** > or < **P.Fn clear** > on the screen on the left, and selecting < **OK** >.

- Even if you clear all Custom Functions, C.Fn-00 will not be cleared.
- P.Fn-03 and 07 are not displayed on the Speedlite 430EX III.

 You can set or clear all Custom Functions of the Speedlite on the camera's menu screen (p.44).

C.Fn: Setting Custom Functions

C.Fn-00: m/ft (Distance indicator display)

You can select the distance indicator display on the LCD panel from meters and feet.

0: m (Meters (m))

1: ft (Feet (ft))

C.Fn-01: (Auto power off)

When the Speedlite is not operated for approx. 90 seconds, the power turns off automatically to save energy. You can disable this function.

0: ON (Enabled)

1: OFF (Disabled)



- When the temperature of the flash head rises due to continuous flash firing, etc., the time until auto power off takes effect may become longer.
- During radio transmission wireless sender flash shooting (p.57) or during linked shooting (p.69), the time until auto power off takes effect is approx. 5 min.

C.Fn-02: MODELING (Modeling flash)

0:  (Enabled (Depth-of-field preview button))

Press the camera's depth-of-field preview button to fire the modeling flash.

1:  (Enabled (Test firing button))

Press the Speedlite's test flash button to fire the modeling flash.

2:  (Enabled (with both buttons))

Press the camera's depth-of-field preview button or the Speedlite's test flash button to fire the modeling flash.

3: OFF (Disabled)

Disables the modeling flash.

C.Fn-08: AF (AF-Assist beam firing)

0: ON (Enabled)

1: OFF (Disabled)

This disables the emission of the AF-assist beam from the Speedlite.

 The flash symbol displayed with C.Fn-08 set changes according to the setting of P.Fn-05 (p.87).

C.Fn-10: (Receiver auto power off timer)

You can change the time for the receiver unit's auto power off to take effect. Note that when the receiver unit's auto power off takes effect,  is displayed on the LCD panel. Set this function on each receiver unit.

0: 60min (60 minutes)

1: 10min (10 minutes)

C.Fn-11: (Receiver auto power off cancel)

When you press the test flash button of sender unit, you can turn on the receiver units in the auto power off status. You can change the time for the receiver units in auto power off status to accept this function. Set this function on each receiver unit.



0: 8h (Within 8 hours)

1: 1h (Within 1 hour)

C.Fn-13: (Flash exposure compensation setting)

0:  +  (Speedlite button and dial)

1:  (Speedlite dial only)

You can directly set the flash exposure compensation amount and flash output by turning  without pressing the  button of the  cross keys.

C.Fn-21:  (Light distribution)

You can change the flash light distribution (flash coverage) of the Speedlite in relation to the shooting angle of view when the flash coverage is set to  (automatic).

0:  (Standard)

The optimum flash coverage for the shooting angle of view is set automatically.

1:  (Guide number priority)

Although the periphery of the picture is slightly darker than the 0 setting, this is convenient when you want to give priority to the flash output. The flash coverage is set automatically to a slightly more telephoto position than the actual shooting angle of view. The display changes to .

2:  (Even coverage)



Although the effective flash shooting distance becomes slightly shorter than the 0 setting, this is convenient when you want to minimize light fall off at the periphery of the picture. The flash coverage is set automatically to a slightly wider position than the actual shooting angle of view. The display changes to .

C.Fn-22:  (LCD panel illumination)

When a button or dial is operated, the LCD panel illuminates. You can change this illumination setting.

0: 12sec (On for 12 sec.)**1: OFF (Disable panel illumination)****2: ON (Illumination always on)****C.Fn-23:  (Receiver flash charge check)**

When the receiver unit is fully charged during wireless flash shooting, the AF-assist beam emitter of the receiver unit blinks. You can disable this operation. Set this function on each receiver unit.

0:  (AF-assist beam,  lamp)**1:  (Lamp)**

P.Fn: Setting Personal Functions

P.Fn-01: (LCD panel display contrast)

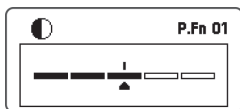

You can adjust the contrast of the LCD panel in 5 levels.

P.Fn-02: (LCD panel illumination color: Normal shooting)

You can select the color of the LCD panel illumination for normal shooting (on-camera flash shooting).

0: GREEN (Green)

1: ORANGE (Orange)

P.Fn-03: (LCD panel illumination color: Sender)

You can select the color of the LCD panel illumination for the Speedlite set as the sender unit for wireless flash shooting using radio transmission or linked shooting. P.Fn-03 is not displayed on the Speedlite 430EX III.

0: GREEN (Green)

1: ORANGE (Orange)

P.Fn-04: (LCD panel illumination color: Receiver)

You can select the color of the LCD panel illumination for the Speedlite set as the receiver unit for wireless flash shooting using radio or optical transmission or linked shooting.

0: ORANGE (Orange)

1: GREEN (Green)

P.Fn-05:  /  AF (AF-assist beam emission method)

You can select AF-assist beam emission method.

0:  (Small series of flashes fired by flash)

AF-assist beam, which uses a small series of flashes, is emitted (p.22).

1:  (Infrared)

Infrared AF-assist beam aiming at the center AF point is emitted. Position the subject in the center of the viewfinder and focus. The effective range is approx. 0.7 - 8 m/2.3 - 26.2 ft.



- When 1 is set, manually select the center AF point. When an AF point other than the center AF point is selected, focusing with the AF-assist beam is not possible (AF-assist beam is not emitted).
- When the color filter is attached (p.37), the AF-assist beam, which uses a series of small flashes, is not emitted. If AF-assist beam is required, set the value to 1.

P.Fn-06:  QUICK (Quick flash)

You can set whether or not to fire the flash when the flash-ready lamp is lit in green (before the flash is fully charged) to shorten the charge waiting time. Quick flash also functions during continuous shooting.

0: ON (Enabled)**1: OFF (Disabled)**

When Quick flash is fired during continuous shooting, underexposure may occur since the flash output decreases.

P.Fn-07: LINKED SHOT (Flash firing during linked shooting)

When performing linked shooting function (p.67), you can set whether or not to fire the flash attached to the camera. Set it on each flash to be used in linked shooting. P.Fn-07 is not displayed on the Speedlite 430EX III.

0: OFF (Disabled)

The flash does not fire during linked shooting.



1: ON (Enabled)

The flash fires during linked shooting.

 If you fire multiple Speedlites at the same time during linked shooting, the appropriate exposure may not be obtained or uneven exposure may result.

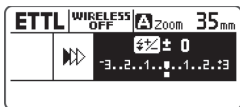
P.Fn-08: DIRECT (Dial setting changes)





When  is pressed and the screen displays the settings as shown on the left, you can set whether or not the following functions can be directly set by simply turning .

0: OFF (Disabled)

This is the normal operation procedure.

1: ON (Enabled)

You can directly specify the settings by simply selecting the “Flash exposure compensation amount”, “Manual flash output”, “Firing group control”, “Flash ratio”, “Flash mode for each firing group in group flash”, and “Receiver firing group” symbols using the  cross keys, and turning .

7

Reference

This chapter provides a system map, trouble shooting guide, use of the Speedlite with Type-B cameras, etc.

430EX III-RT/430EX III System

Wireless Flash Shooting

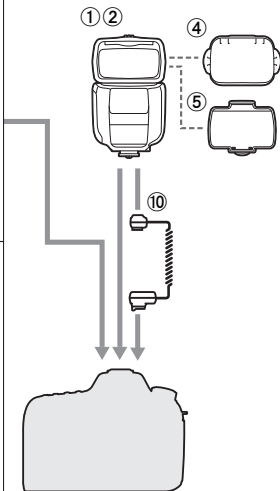
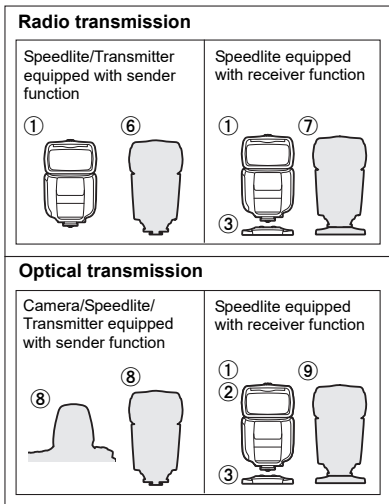

- ① **Speedlite 430EX III-RT**
- ② **Speedlite 430EX III**
- ③ **Mini stand** (provided with 430EX III-RT/430EX III)
- ④ **Bounce adapter SBA-E2** (provided with 430EX III-RT/430EX III)
- ⑤ **Color filter SCF-E2** (provided with 430EX III-RT/430EX III)

- ⑥ **Device equipped with radio transmission wireless sender function**
600EX-RT and ST-E3-RT
- ⑦ **Speedlite equipped with radio transmission wireless receiver function**
600EX-RT
- ⑧ **Device equipped with optical transmission wireless sender function**
600EX-RT, 600EX, 580EX II, 580EX, 550EX, 90EX, MT-24EX, MR-14EX II, MR-14EX, ST-E2, and EOS DIGITAL cameras with optical transmission wireless sender function by built-in flash
- ⑨ **Speedlite equipped with optical transmission wireless receiver function**
600EX-RT, 600EX, 580EX II, 580EX, 550EX, 430EX II, 430EX, 420EX, 320EX, 270EX II
- ⑩ **Off-Camera Shoe Cord OC-E3**
Enables the 430EX III-RT/430EX III to be connected to the camera up to approx. 60 cm / 2 ft. away.



 When using a Speedlite without a function for switching the firing groups (A, B, C) in ⑨, you can use the Speedlite as a receiver in firing group A during wireless flash shooting (you cannot use it as a receiver in firing group B or C).

Flash Firing Restriction due to Temperature Increase

When continuous flash or modeling flash is repeatedly fired in short intervals, the temperature of the flash head, batteries, and the area near the battery compartment may increase. Repeated firings of the flash automatically activates the flash firing restriction to avoid degrading or damaging the flash head due to overheating. When flash firing is restricted, a warning icon is displayed to indicate the increase in temperature, and the firing interval (with which the flash shootings can be performed) is set automatically between approx. 8 and 25 sec.

Temperature Increase Warning

As the internal temperature of the Speedlite increases, the warning is displayed in two levels.

Display	Level 1 (Firing Interval: Approx. 8 sec.)	Level 2 (Firing Interval: Approx. 25 sec.)
Icon		
LCD panel	Red (lit)	Red (blinking)

Number of Continuous Flash and Rest Time

The following table shows the number of continuous flash until the warning is displayed, and the necessary rest time (guideline) until normal flash shooting can be performed.

Function	Number of Continuous Flash to Reach Level 1 Warning (Guideline)	Necessary Interval Time (Guideline)
Continuous flash* (p.15)	32 times or more	20 min. or longer
Modeling flash (p.36)		

* At full output.



- Even when Level 1 warning is not displayed, the firing interval will be extended as the flash head begins to heat up.
- If Level 2 warning is displayed, allow a rest time for at least 30 min.
- For cautions on the number of flash firings, see page 15 (continuous flashes) or page 36 (modeling flash).
- When Level 2 warning is displayed and remote release (p.66), test flash or modeling flash (p.65) is performed by a receiver, the firing interval becomes approx. 40 sec.
- Do not touch the flash head, batteries, or the area near the battery compartment immediately after firing continuous flash or modeling flash. Touching them may result in a burn. Before replacing the batteries, make sure that they are cooled.
- When C.Fn-22-1 is set (p.85), the warning with red illumination of the LCD panel will not be displayed even if the temperature of the flash head rises.

Troubleshooting Guide

If a problem occurs with the flash, first refer to this Troubleshooting Guide. If this Troubleshooting Guide does not resolve the problem, contact your dealer or nearest Canon Service Center.

● Normal Shooting

The power does not turn on.

- Make sure that the batteries are installed in the correct orientation (p.16).
- Make sure that the battery compartment cover is closed (p.16).
- Replace the batteries with new ones.

The Speedlite does not fire.

- Insert the mounting foot into the camera's hot shoe all the way, slide the lock lever to the right, and secure the Speedlite to the camera (p.17).
- If the < **CHARGE** > indication remains displayed for approx. 40 sec. or longer, replace the batteries (p.16).
- If the electrical contacts of the Speedlite or camera are dirty, wipe the contacts (p.10) with a dry cloth, etc.
- When you perform continuous firing repeatedly over a short period of time, causing the temperature of the flash head to rise and flash firing to be restricted, the firing interval increases (p.92).

The power turns off by itself.

- The Speedlite's auto power off has activated. Press the shutter button halfway or press the test flash button (p.18).

Pictures are underexposed or overexposed.

- If the main subject looks very dark or very bright, set flash exposure compensation (p.24).
- If there is a highly reflective object in the picture, use FE lock (p.25).
- With high-speed sync, the faster the shutter speed, the lower the guide number becomes. Move closer to the subject (p.26).

The bottom of the picture looks dark.

- Move at least 0.7 m/2.3 ft. away from the subject.
- Remove the lens hood if attached.

The picture periphery looks dark.

- Set the flash coverage to **<A>** (automatic) (p.32).
- When using the manual setting for the flash coverage, set a flash coverage wider than the shooting angle of view (p.32).
- Check that C.Fn-21-1 is not set (p.85).

The picture is very blurred.

- When the shooting mode is set to the aperture-priority AE **<Av>** mode and the scene is dark, slow sync is enabled automatically (the shutter speed becomes slower). Use a tripod or set the shooting mode to the program AE **<P>** or fully automatic mode (p.21). Note that you can also set the sync speed in **[Flash sync. speed in Av mode]** (p.42).

The flash coverage is not set automatically.

- Set the flash coverage to **<A>** (automatic) (p.32).
- Insert the mounting foot into the camera's hot shoe all the way, slide the lock lever to the right, and secure the Speedlite to the camera (p.17).

The flash coverage cannot be set manually.

- Remove the bounce adapter (p.30).
- Retract the wide panel (p.33).

The AF-assist beam does not fire.

- When the color filter is attached, the AF-assist beam, which uses a series of small flashes, is not emitted. Set P.Fn-05-1 (p.87).

Functions cannot be set (**LOCKED** displayed).

- Set the camera's shooting mode to **<P>**, **<Tv>**, **<Av>**, **<M>**, or **** (Creative Zone mode).
- Set the power switch to the **<ON>** position.

● Radio Transmission Wireless Flash Shooting

Wireless shooting does not work.

- When using a “Speedlite 430EX III”, which is not equipped with the radio transmission function, wireless flash shooting using radio transmission is not available. Perform flash shooting using the optical transmission wireless receiver function.

The receiver unit does not fire.

- Set the sender to <(☺) **SENDER**> and the receiver to <(☺) **RECEIVER**> (p.50).
- Set the transmission channels and wireless radio IDs of the sender unit and receiver unit to the same numbers (p.50-52).
- Check that the receiver unit is within the transmission range of the sender unit (p.46).
- The camera’s built-in flash cannot be used as the sender unit in radio transmission wireless shooting.
- 430EX III-RT does not support <**Ext.A**> auto external flash metering (p.65).

The receiver unit does not fire or unexpectedly fires at full output.

- Run the transmission channel scan and set the channel with the best reception signal (p.52).
- Position the receiver unit at a location with possible clearest view of the sender unit.
- Face the front side of the receiver’s main body toward the sender unit.

Pictures are overexposed.

- When using autoflash shooting with three firing groups A, B, and C, do not fire with firing group C pointed toward the main subject (p.61).
- When shooting in a different flash mode set for each firing group, do not fire with multiple firing groups set to <**ETTL**> or <**Ext.A**> pointing toward the main subject (p.65).

<TV> is displayed.

- Set the shutter speed 1 stop slower than the flash sync speed (p.49).

The LCD panel illumination turns on and off.

- The sender unit's LCD panel illuminates or turns off according to the charge status of the sender unit and receiver units (firing groups). See "LCD Panel Illumination" on page 54.

● Linked Shooting**Standard exposure is not obtained / Uneven exposure occurs.**

- If you fire multiple Speedlites at the same time during linked shooting, the appropriate exposure may not be obtained or uneven exposure may result. It is recommended to set only one Speedlite to fire or to use a self-timer to space out the timing of the flashes.

● Optical Transmission Wireless Flash Shooting**The receiver unit does not fire.**

- Set the receiver unit to <⚡ **RECEIVER**> (p.73).
- Set the transmission channels of the sender unit and receiver unit to the same numbers (p.73).
- Check that the receiver unit is within the transmission range of the sender unit (p.72).
- Point the wireless sensor of the receiver unit toward the sender unit (p.72).
- If the sender unit and receiver unit are too close, the transmission may not take effect properly.
- When using the camera's built-in flash as the sender unit, raise the camera's built-in flash, and set [**Wireless func.**] on the camera's [**Built-in flash func. setting**] screen.

Specifications

● Type

Type:	E-TTL II/E-TTL autoflash Shoe-mount Speedlite
Compatible cameras:	Type-A EOS cameras (E-TTL II/E-TTL autoflash) * Autoflash is not possible when using Type-B EOS cameras.

● Flash Head (Light-emitting unit)

Guide No.:	Approx. 43/141.1 (at 105 mm flash coverage, ISO 100, in meters/feet) * Without color filter or bounce adapter
Flash coverage:	Supports a shooting angle of view with a lens focal length of 24-105 mm (with wide panel use: 14 mm) <ul style="list-style-type: none">• Automatic setting (Automatically sets the flash coverage depending on the shooting angle of view and the image sensor size.)• Manual setting
Bounce:	90° up, 150° left, 180° right Bounce adapter provided can be used
Flash duration:	Normal flash: Approx. 1.8 ms or less, Quick flash: 2.3 ms or less
Color temperature information transmission:	Flash light color temperature information transmitted to camera when flash is fired
Color filter:	Color filter provided can be used

● Exposure Control

Exposure control system:	E-TTL II/E-TTL autoflash, manual flash
Effective flash range: (with EF50mm f/1.4 lens at ISO 100)	Normal flash: Approx. 0.7 - 23.6 m / 2.3 - 77.4 ft. Quick flash: Approx. 0.7 - 13.6 m / 2.3 - 44.6 ft. (at Guide No. 19.1/62.7, in meters/feet) High-speed sync: Approx. 0.7 - 12.8 m / 2.3 - 42.0 ft. (at 1/250 sec.)
Flash exposure compensation:	±3 stops in 1/3- or 1/2-stop increments
FE lock:	Possible with the camera's Multi-function button or FE lock/AE lock buttons
High-speed sync:	Possible * During radio transmission wireless shooting, high-speed sync is possible only with EOS DIGITAL cameras released in and after 2012 (except with EOS REBEL T5/1200D).
Manual flash:	1/1 - 1/128 power (1/3-step increments)
Modeling flash:	Fired with camera's depth-of-field preview button or Speedlite's test flash button

● Flash Recycling

Firing interval (Recycling time):	Normal flash: Approx. 0.1 - 3.5 sec., Quick flash: Approx. 0.1 - 2.5 sec. * When using AA/LR6 alkaline batteries
Flash-ready lamp:	Lights up in red: normal flash available Lights up in green: Quick flash available

● AF-Assist Beam

Emission method:	Switchable in Personal Functions between Intermittent flashes (a series of small flashes) and Infrared AF-assist beam
Emitting small series of flashes:	Supported during viewfinder shooting, and Quick mode during Live View shooting or movie shooting Effective distance: At center: Approx. 0.7 - 4 m / 2.3 - 13.1 ft., At periphery: Approx. 0.7 - 3.5 m / 2.3 - 11.5 ft.
Infrared AF-assist beam:	Center AF point in viewfinder supported Effective distance: Approx. 0.7 - 8 m / 2.3 - 26.2 ft.

● Radio Transmission Wireless Sender/Receiver Function (430EX III-RT only)

Frequency:	2405 MHz - 2475 MHz
Modulation system:	Primary modulation: OQPSK, Secondary modulation: DS-SS
Wireless settings:	Sender/receiver
Channel:	Auto, Ch. 1 - 15
Wireless radio ID:	0000 - 9999
Receiver unit control:	Up to 5 groups (A, B, C, D, E), up to 15 units
Receiver unit setting:	Firing group A, B, C, D, E
Transmission distance:	Approx. 30 m / 98.4 ft. * When there are no obstacles or obstructions between the sender and receiver units with no radio interference with other devices * Transmission distance may be shorter depending on the relative positions of the units, surrounding environment, weather conditions, etc.
Flash ratio control:	1:8 - 1:1 - 8:1, 1/2-step increments
Receiver flash charge confirmation:	Receiver unit charge status and receiver flash ready icon are displayed on the sender unit's LCD panel, AF-assist beam emitter blinks and flash-ready lamp lights up on the receiver unit
Linked shooting:	Possible

● Optical Transmission Wireless Receiver Function

Connection method:	Optical pulse
Wireless settings:	Receiver
Channel:	Ch. 1 - 4
Receiver unit setting:	Firing group A, B, C
Reception angle:	$\pm 40^\circ$ horizontally and $\pm 30^\circ$ vertically, facing the sender unit
Receiver flash charge indication:	AF-assist beam emitter blinks and flash-ready lamp lights up on the receiver unit

● Customizable Functions

Custom Functions:	10 types
Personal Functions:	430EX III-RT: 8 types / 430EX III: 6 types

● Power Source

Speedlite power source:	Four AA/LR6 alkaline batteries * AA/HR6 Ni-MH batteries can be used
Battery life (number of flashes):	Approx. 180 - 1200 times * When using AA/LR6 alkaline batteries
Radio transmission wireless shooting time:	Approx. 9 continuous hours * When Sender flash firing OFF, using AA/LR6 alkaline batteries
Auto power off:	Power off after approx. 90 sec. of idle operation * When set as radio transmission wireless sender unit, or in linked shooting: approx. 5 min. * When set as receiver unit: approx. 60 min.

● Dimensions and Weight

Dimensions (W x H x D):	Approx. 70.5 x 113.8 x 98.2 mm / 2.78 x 4.48 x 3.87 in.
Weight:	430EX III-RT: Approx. 295 g / 10.41 oz., 430EX III: Approx. 290 g / 10.23 oz. (Speedlite only, excluding batteries)

● Operation Environment

Working temperature range:	0 °C - 45 °C / 32 °F - 113 °F
Working humidity:	85 % or less

- All specifications above are based on Canon's testing standards.
- Product specifications and the exterior are subject to change without notice.

Guide Number (ISO 100, in approx. meters/feet)**Normal Flash (Full Output)/Quick Flash**

Flash Coverage (mm)	14	24	28	35
Normal Flash (Full Output)	14.0 / 45.9	22.0 / 72.2	24.0 / 78.7	28.0 / 91.9
Quick Flash	Same as approx. 1/2 - 1/3 of full output			

Flash Coverage (mm)	50	70	80	105
Normal Flash (Full Output)	33.0 / 108.3	40.0 / 131.2	41.0 / 134.5	43.0 / 141.1
Quick Flash	Same as approx. 1/2 - 1/3 of full output			

Manual Flash

Flash Output	Flash Coverage (mm)			
	14	24	28	35
1/1	14.0 / 45.9	22.0 / 72.2	24.0 / 78.7	28.0 / 91.9
1/2	9.9 / 32.5	15.6 / 51.2	17.0 / 55.8	19.8 / 65.0
1/4	7.0 / 23.0	11.0 / 36.1	12.0 / 39.4	14.0 / 45.9
1/8	5.0 / 16.4	7.8 / 25.6	8.5 / 27.9	9.9 / 32.5
1/16	3.5 / 11.5	5.5 / 18.0	6.0 / 19.7	7.0 / 23.0
1/32	2.5 / 8.2	3.9 / 12.8	4.2 / 13.8	5.0 / 16.4
1/64	1.8 / 5.9	2.8 / 9.2	3.0 / 9.8	3.5 / 11.5
1/128	1.2 / 3.9	1.9 / 6.2	2.1 / 6.9	2.5 / 8.2

Flash Output	Flash Coverage (mm)			
	50	70	80	105
1/1	33.0 / 108.3	40.0 / 131.2	41.0 / 134.5	43.0 / 141.1
1/2	23.3 / 76.4	28.3 / 92.8	29.0 / 95.1	30.4 / 99.7
1/4	16.5 / 54.1	20.0 / 65.6	20.5 / 67.3	21.5 / 70.5
1/8	11.7 / 38.4	14.1 / 46.3	14.5 / 47.6	15.2 / 49.9
1/16	8.3 / 27.2	10.0 / 32.8	10.3 / 33.8	10.8 / 35.4
1/32	5.8 / 19.0	7.1 / 23.3	7.3 / 24.0	7.6 / 24.9
1/64	4.1 / 13.5	5.0 / 16.4	5.1 / 16.7	5.4 / 17.7
1/128	2.9 / 9.5	3.5 / 11.5	3.6 / 11.8	3.8 / 12.5

Using with a Type-B Camera

This section describes the available and unavailable functions when using the Speedlite 430EX III-RT/430EX III with a Type-B camera (EOS film camera supporting A-TTL/TTL autoflash).

Although <ETTL> is displayed on the flash LCD panel when the Speedlite is attached to a Type-B camera, autoflash is not

available. If you take a picture in this status, the flash will always fire at full output.

Functions available with Type-B cameras

- Manual flash
- Second-curtain sync

Functions not available with Type-B cameras

- E-TTL II/E-TTL/TTL autoflash
- Speedlite flash exposure compensation
- FE lock
- High-speed sync
- Quick flash
- Modeling flash
- Wireless flash shooting with radio transmission
- Linked shooting

Radio Transmission Wireless Function

■ Countries and Regions Permitting Radio Transmission Wireless Function Use

Use of radio transmission wireless function is restricted in some countries and regions, and illegal use may be punishable under national or local regulations. To avoid violating radio transmission wireless function regulations, visit the Canon Web site to check where use is allowed.

Note that Canon cannot be held liable for any problems arising from radio transmission wireless function use in other countries and regions.

■ Model Number

430EX III-RT : DS401121 (including radio transmission wireless module model: CH9-1216)

**Complies with
IDA Standards
DB00671**

This equipment is installed with the Radio Transmission Wireless Module which is certified to standards set by IDA Singapore.

FCC/IC NOTICE

**Model: DS401121 (including Radio Transmission Wireless Module
Model: CH9-1216, FCC ID: AZD216 / IC: 498J-216)**

This device complies with Part 15 of FCC Rules and Industry Canada's licence-exempt RSSs. Operation is subject to the following two conditions: (1) this device may not cause harmful interference, and (2) this device must accept any interference received, including interference that may cause undesired operation.

This equipment must not be co-located or operated in conjunction with any other antenna or equipment except Canon accessories supplied or designated for this product.

This equipment complies with FCC/IC radiation exposure limits set forth for an uncontrolled environment and meets the FCC radio frequency (RF) Exposure Guidelines and RSS-102 of the IC radio frequency (RF) Exposure rules. This equipment has very low levels of RF energy that are deemed to comply without testing of specific absorption rate (SAR).

Hereby, Canon Inc. declares that this 430EX III-RT, CH9-1216 is in compliance with the essential requirements and other relevant provisions of Directive 1999/5/EC.

Please contact the following address for the original Declaration of Conformity:

CANON EUROPA N.V.

Bovenkerkerweg 59, 1185 XB Amstelveen, The Netherlands

CANON INC.

30-2, Shimomaruko 3-chome, Ohta-ku, Tokyo 146-8501, Japan



Model: DS401121/ DS401122 systems

This device complies with Part 15 of the FCC Rules. Operation is subject to the following two conditions: (1) This device may not cause harmful interference, and (2) this device must accept any interference received, including interference that may cause undesired operation.

Note: This equipment has been tested and found to comply with the limits for class B digital devices, pursuant to Part 15 of the FCC Rules. These limits are designed to provide reasonable protection against harmful interference in a residential installation. This equipment generates, uses and can radiate radio frequency energy and, if not installed and used in accordance with the instructions, may cause harmful interference to radio communications. However, there is no guarantee that interference will not occur in a particular installation. If this equipment does cause harmful interference to radio or television reception, which can be determined by turning the equipment off and on, the user is encouraged to try to correct the interference by one or more of the following measures:

- Reorient or relocate the receiving antenna.
- Increase the separation between the equipment and receiver.
- Connect the equipment into an outlet on a circuit different from that to which the receiver is connected.
- Consult the dealer or an experienced radio/TV technician for help.

Do not make any changes or modifications to the equipment unless otherwise specified in the manual. If such changes or modifications should be made, you could be required to stop operation of the equipment.

CAN ICES-3 (B) / NMB-3 (B)

The apparatus shall not be exposed to dripping or splashing.

Batteries shall not be exposed to excessive heat such as sunshine, fire, or the like.

Dry batteries shall not be subjected to charging.



Only for European Union and EEA (Norway, Iceland and Liechtenstein)

This symbol indicates that this product is not to be disposed of with your household waste, according to the WEEE Directive (2012/19/EU) and national legislation. This product should be handed over to a designated collection point, e.g., on an authorized one-for-one basis when you buy a new similar product or to an authorized collection site for recycling waste electrical and electronic equipment (EEE). Improper handling of this type of waste could have a possible negative impact on the environment and human health due to potentially hazardous substances that are generally associated with EEE. At the same time, your cooperation in the correct disposal of this product will contribute to the effective usage of natural resources. For more information about where you can drop off your waste equipment for recycling, please contact your local city office, waste authority, approved WEEE scheme or your household waste disposal service. For more information regarding return and recycling of WEEE products, please visit www.canon-europe.com/weee.

Index

- Numerics**
12 sec., 16 sec. timer..... 4
- A**
Accessory shoe 17
AF-assist beam..... 22, 81, 84, 87
Auto power off..... 18, 83, 84
Auto zoom adjustment to image sensor size..... 22
Av (Aperture-priority AE)..... 21
- B**
Batteries..... 16
Bounce..... 28
Bounce adapter 30
- C**
C.Fn..... 80, 81, 83
Case 14
Catchlight shooting 29
Clear all..... 44, 82
Clearing settings
(Reverting to defaults) 38, 41
Color filter 14, 37, 90
Color temperature information transmission..... 22
Creative Zone 4, 23, 39, 45, 71, 79
☆ (Creative Zone) icon..... 4
Custom Functions (C.Fn).... 80, 81, 83
- D**
Distance indicator display ... 20, 34, 83
- E**
Effective flash range 12, 20
E-TTL II (flash metering)..... 42
E-TTL II/E-TTL autoflash 20, 21
- F**
FE lock..... 25
Firing groups..... 59, 60, 62, 63, 77
Firing interval 16, 92
- 106
- First-curtain sync..... 42
Flash control..... 40
Flash coverage..... 32, 85
Flash exposure compensation..... 24, 42, 58, 77
Flash exposure level 12, 24, 35
Flash firing restriction 92
Flash function setting 39
Flash head
(Light-emitting unit) 10, 28
Flash metering 42
Flash mode 12, 20, 34, 42
Flash operation (transmission) range 46, 72
Flash output 34, 62
Flash positions 46, 72
Flash ratio
 Three groups (A:B C)..... 60
 Two groups (A:B)..... 59
Flash sync. speed 42, 49
Flash sync. speed in Av mode 42
Flash-ready lamp 18, 56, 87
Fully automatic flash photography... 20
Function settings 39
- G**
Group control 61
Group firing 63
Guide number 101
- H**
High-speed sync 26, 49, 58, 77
- I**
INDIVIDUAL RECEIVER..... 13, 78
Individual receiver 78
- L**
LCD panel 12
 Contrast 86
 Illumination..... 19, 54, 85

- Illumination color.....86
 Light distribution.....85
 Light-emitting unit
 (Flash head).....10, 28
 LINK.....11, 53, 56
 Linked shooting.....13, 67, 88
 LOCK.....19
 Lock function.....19
- M**
- M (Manual exposure).....21
 M (Manual flash).....34, 62
 Manual flash.....34, 62
 Memory function.....54, 74
 Metered manual flash.....35
 Modeling flash.....36, 65
- N**
- Normal flash.....16, 101
 Number of flashes.....16
- O**
- Optical transmission wireless flash
 shooting.....71
- P**
- P (Program AE).....20
 P.Fn.....80, 81, 86
 Personal Functions (P.Fn)...80, 81, 86
 Power switch.....18
- Q**
- Quick flash.....16, 18, 87
- R**
- Radio transmission wireless flash
 shooting.....45
 Fully automatic one receiver unit...55
 Fully automatic three groups
 (A:B C).....60
 Fully automatic two groups
 (A:B).....59
- Group firing.....63
 Manual flash.....62
 Receiver unit.....13, 45, 71
 Charge indication.....54, 56, 76, 85
 Receiver unit setting.....50, 73
 Recycling.....18
 Remote release.....66
- S**
- Scan.....52
 Second-curtain sync.....27
 Sender flash firing ON/OFF.....53
 Sender unit.....13, 45, 71
 Sender unit setting.....50
 Shutter speed.....21
 Shutter sync settings.....42
 Sync speed.....21, 42, 49
 System map.....90
- T**
- Temperature increase.....92
 Test flash.....18, 56, 65, 76
 Transmission channel.....50, 73
 Transmission distance.....46, 48, 72
 Transmitter.....67, 90
 TTL autoflash.....102
 Tv (Shutter-priority AE).....21
 Type-A camera.....2
 Type-B camera.....102
- W**
- Warning.....92
 Wide panel.....33
 Wireless button.....11, 50, 73
 Wireless radio ID.....50, 51
 Wireless settings.....50, 73
 Wireless shooting.....45, 71
- Z**
- Zoom.....32

Canon