



Remote Camera

User Manual

CR-X300 Firmware ver. 1.3.0

Table of Contents

	Introduction.....	6
	Safety Precautions and Handling Instructions (Disclaimer)	6
	Trademarks	9
	Software License Agreement.....	9
	Third Party Software.....	9
	User Manuals.....	12
	Types of User Manuals	12
	How to Use This Document	12
	Names of Parts	13
	Receptacle Unit	14
	Examples of System Configuration.....	17
Chapter 1	Installation and Connection	
	Installation.....	20
	Carrying the Product.....	20
	Mounting the Head Unit	20
	Using a Tripod	21
	Attaching the Connector Cover	21
	Routine Maintenance.....	23
	Confirmation of Video Image	23
	Cleaning Method.....	23
Chapter 2	Default Settings	
	Security Checking/Settings	25
	Checking the Firewall Settings (Windows).....	25
	Initial Camera Settings.....	26
	Settings Using the Camera Search Tool.....	26
	Camera's Settings Page from the Web Browser.....	28
Chapter 3	Camera Setup	
	Overview.....	30
	Accessing from a Web Browser	30
	Configuration of the Settings Page	30
	Camera Operation	34
	Operation by Clicking on the Video Display Area or by Slider	34
	Exposure Settings.....	36
	WB/Color Settings.....	41
	Image Quality Settings	43
	Image Quality Details Settings	44
	Focus Settings	46
	Autofocus.....	46
	Manual Focus.....	48

PTZ/IS Settings	49
Preset Settings.....	50
Registering Presets.....	50
Calling Presets and Speed Specification	51
Deleting Presets.....	52
Other Functions Settings	53
System Settings	54
Screen Configuration	54
Setting Items	55
Common Operations.....	55
[System] > [Video and Audio] > [HDMI/SDI]	57
HDMI/SDI	57
SDI	57
[System] > [Video and Audio] > [IP Streaming Video].....	58
Mainstream	58
Substream 1.....	59
Substream 2.....	59
[System] > [Video and Audio] > [Audio].....	60
General audio	60
IP Audio Streaming	60
[System] > [Video and Audio] > [Movement Range].....	61
Pan/Tilt	61
[System] > [Server] > [HTTP/Video].....	62
HTTP Server	62
Video Server.....	62
[System] > [Server] > [RTP]	63
RTP Server	63
Audio Settings.....	63
RTP Mainstream, RTP Substream 1, RTP Substream 2.....	64
[System] > [Communication] > [Network].....	65
LAN	65
IPv4	65
IPv6	66
DNS.....	66
mDNS.....	67
[System] > [Communication] > [External Connection (IP)].....	68
Standard Communication (IP).....	68
NDI HX	68
RTMP.....	69
Output Tracking Data.....	69
SRT.....	70
[System] > [Communication] > [External Connection (Serial)]	72
Serial Port.....	72
Standard Communication (Serial).....	73
[System] > [Security] > [Certificate Management]	74
Server Certificate Management	74
Create Certificate	74

[System] > [Security] > [SSL/TLS]	75
Encrypted Communications.....	75
Server Certificates.....	75
[System] > [Security] > [User Management]	76
Administrator Account	77
Authorized User Account.....	77
User Authority	77
[System] > [Security] > [Host Access Restrictions].....	78
IPv4 Host Access Restrictions	78
IPv6 Host Access Restrictions	79
[System] > [System] > [Camera]	80
Camera Name.....	80
Installation Conditions.....	80
Camera Control.....	81
Color Bars	81
AUX OUT.....	81
Tally Lamp.....	82
Genlock.....	82
[System] > [System] > [Add-On]	83
Add-On Management	83
Information About the Selected Application	84
[System] > [System] > [Date and Time].....	85
Current Date and Time.....	85
Settings	85
[System] > [System] > [Environment]	87
Environment	87
[System] > [Maintenance] > [General]	88
Device Information	88
Tool	88
Initialization	88
[System] > [Maintenance] > [Backup/Restore]	90
Backup.....	90
Restore.....	90
[System] > [Maintenance] > [Update Firmware]	91
Device Information	91
Update Firmware	91
[System] > [Maintenance] > [Log]	92
View Logs.....	92

Chapter 4

Appendix

Troubleshooting.....	94
List of Log Messages	96
Log Messages on the Camera.....	96
Error Log	96
Warning Log.....	99
Notification Log	102

Restoring to the Factory Default Settings	106
Restoring to the Initial Settings from a Web Browser.....	106
Restoring to the Factory Default Settings with the RESET Switch on the Camera.....	106
List of Factory Default Settings	107
Specifications	110
CR-X300 Main Unit.....	110
Operating Environment.....	113
Appearance.....	114
Security Measures	116
Basic Measure 1: Setting Administrator Name and Password	117
Basic Measure 2: Using the Latest Firmware	117
Basic Measure 3: Setting Date and Time	117
Basic Measure 4: Monitoring the Log	117
Measures Suitable to the Users' Environment 1: User Management	118
Measures Suitable to the Users' Environment 2: Host Access Restrictions	118
Measures Suitable to the Users' Environment 3: Setting to the Digest Authentication.....	118
Measures Suitable to the Users' Environment 4: Changing the Port Number	119
Measures Suitable to the Users' Environment 5: Encrypting Communication.....	119
Measures Suitable to the Users' Environment 6: Disabling Unused Functions.....	119
Precautions When Disposing the Camera	120
Encrypting Backup Information	120
Index.....	121

Introduction

Thank you for purchasing a Canon Remote Camera (hereafter referred to as the camera).

This "User Manual" explains the camera installation, settings and operations. Read this document carefully before using the camera to ensure correct use. In addition, please be sure to read the next section, "Safety Precautions and Handling Instructions (Disclaimer)".

For the latest information on this product (firmware and software, user manuals, operating environment, etc.), refer to the Canon website.

Safety Precautions and Handling Instructions (Disclaimer)

Be sure to read these instructions in order to operate the product safely. Follow these instructions to prevent injury or harm to the operator of the product or others.

 Warning	Failure to follow the instructions may result in death or serious injury.
--	---

Installation

Request a professional installer for all installation work.

Never try to install the product yourself. Doing so may result in unforeseen accidents such as dropping the camera or electric shock. For installation or inspection of this camera, consult the dealer where you purchased the product.

Wiring work such as power supply and network should be carried out safely and securely in accordance with the relevant regulations.

Do not install the product in a location where there is the risk of ignition or combustion.

Installing the product in a location where flammable gases are produced or concentrated may cause ignition and result in fire.

Do not install the product in unstable places, places subject to significant vibration or impact, or places subject to salt damage or corrosive gas.

When installing the product in an elevated location, make sure to take appropriate measures in advance to prevent the equipment and parts from falling off.

Be sure to attach a safety wire when installing in a high place.

Depending on the installation location, install in such a way that sufficient holding strength can be secured.

Make sure that the mounting location and brackets and screws used for the mounting are capable of withstanding the total weight.

Failure to do so may result in the product falling or other accidents.

Do not install the product in locations subject to high temperatures, such as places exposed to excessive heat, near heat-generating objects, or in confined or enclosed places.

When installed outdoors, attach the included connector cover and protect the connection of the cover and a commercially available wiring hose using a commercially available cable protecting cover to prevent the intrusion of rain, etc.

When thunder starts to sound, stop installation or inspection, etc., and do not touch the camera, connection cable, etc.

Failure to follow the instructions may result in fire or electric shock.

Do not use the product for medical devices or other life-support systems.

Canon will assume no liability for any accident or damage resulting from use of the product under the conditions above.

Power Supply

Connect the power cable securely by inserting the plug fully into the camera correctly on one end, and properly wiring the other end.

Failure to follow the instructions may result in fire or electric shock.

Do not connect or disconnect the power cable or plug with wet hands.

Failure to do so may result in electric shock.

Do not leave the product plugged in for extended periods of time in locations exposed to high levels of dust, moisture or oily smoke.

Doing so may cause insulation failures and even fires.

Periodically wipe the terminal of the power cable and power outlet with a dry cloth to remove dust buildup.
Failure to follow the instructions may result in fire.

When using the DC IN 12V terminal, use the included power cable.
Using an unsuitable power cable may cause electric shock and fire.

When using a commercially available AC adaptor, use one that complies with the safety standards.
Using an unsuitable AC adapter may cause electric shock and/or fire.

If DC power is not used, do not connect the power cable.
Turn off the power when the camera is not used for a long period of time.
Failure to follow the instructions may result in fire or electric shock.

Handling

If any defective conditions such as smoke, strange sounds, heat, strange odors, damage or cracks on the external case are discovered, immediately stop using the product, disconnect from the power supply, and contact your nearest dealer.

Do not use flammable sprays near the product.

Do not allow liquids or foreign matter inside the unit.

Failure to follow the instructions may result in fire or electric shock.

Do not expose the product to strong shocks or vibration.

Failure to do so may result in the product falling or other accidents.

Do not scratch, pull, or forcefully bend the cables, or put a load on their connections.

Failure to follow the instructions may damage the cable, cause electrical leakage, and result in fire or electric shock.

Maintenance and Inspection

Stop the power supply before cleaning it.

Cleaning the product with a wet cloth with the power being supplied may result in electric shock.

Do not use organic solvents such as alcohol, benzene or paint thinner to clean the product.

Failure to follow the instructions may result in fire.

Do not disassemble or modify the product.

Failure to follow the instructions may result in fire or electric shock.

Inspect mountings regularly (every six months to one year) to ensure that screws are not rusted or they are securely tightened.

Failure to do so may result in the product falling or other accidents.

 Caution	Failure to observe the following precautions may result in injury or property damage.
--	---

Installation

Take care not to damage wiring or piping.

Failure to do so may result in damage to peripheral items.

Handling

Make sure that there are no people within the operating range of pan-tilt head section and camera housing section.

Do not touch the pan-tilt head section and the camera housing section during initialization.

The product hitting a person may cause injury.

Do not touch the edges of metal parts with bare hands.

Failure to do so may result in injuries.

■ Handling Precautions

- Do not hold the camera housing section. Failure to follow the instructions may result in damage.
- Take measures to remove static electricity before performing any procedures.
- Do not connect a PoE cable to the RS-422 terminal.
- Confirm that the video can be captured correctly, before using the camera, when the power is turned on for the first time after installation, or after not being turned on for a long time.
- After turning off the power, do not turn the power on again for at least five seconds.

- Do not point the camera at strong light sources (such as the sun on a clear day or strong artificial light sources). Internal components such as the image sensor could be damaged.
- Do not use or store the product outside the operating or storage environment. Failure to do so may result in damage due to the degradation of image quality or internal components.
- This product complies with the Dust-resistant/Waterproof Specification (IP65) rating. However, long exposure to rain may result in the corrosion of the outer shell, due to acid and heavy metals in the rain water.
- If there is condensation, wait to power on, until the condensation dissipates.
- Beware of freezing conditions. The product does not have a freeze-proof structure so take precautions when installing it in locations that may freeze. The product may not operate correctly if frozen.
- If the camera is installed outdoors, rain, snow, frost, etc. may adhere to the lens protector on the front of the camera, and visibility of the acquired video can be impaired. In addition, the lens protector may become dirty and the image quality may deteriorate due to the effect of dust or automobile exhaust fumes in the air. When installing the product outdoors, pay close attention to the impact of the surroundings on the video.
- Move the pan-tilt head regularly. Dust, water, snow, etc. may accumulate and cause image degradation or malfunction. In addition, to prevent dust from sticking to the lens, it is recommended that the pan-tilt head be tilted down with the enhanced ND filter activated when not in use for a long period of time.
- Pan and tilt may not operate properly in locations where strong winds may blow at 15 m/s or more.
- Do not use for vehicle-mounted operations. Vibration may cause loss of image quality or damage to internal components.



Important

- To prevent lightning damage, it is recommended to use a lightning rod or arrester (surge protective device or lightning protection transformer).

Disclaimer

- Canon shall bear no responsibility for damage resulting from improper operation of this product by the customer.
- Regarding this product's quality, functionality or instruction manual, Canon shall make no guarantees about its marketability or suitability for the customer's purpose. Moreover, Canon shall not be liable for any damage, direct or incidental, that results from using the product for the customer's purpose.
- Canon shall bear no responsibility for any loss, damage, direct or indirect, or any incidental loss, damage (including filming expenses and loss of filming earnings) arising out of the failure of this product or arising out of the use of this product.
- The product specifications, configuration, and appearance are subject to change without prior notice.
- For further information on repairs, maintenance, or adjustments not mentioned in this instruction manual, contact a Canon sales representative.
- Note that Canon may be unable to undertake servicing or repair of a product if it is modified without consulting Canon or your Canon sales representative.

Compliance with Applicable Laws/intellectual Property Rights: Please note that your use of this product may subject you to certain laws, rules and regulations, including but not limited to, privacy, wiretapping and intellectual property and publicity laws. Please be sure your use of this product and/or any resulting recordings or footage complies with applicable laws, rules and regulations.

Canon Inc. and its affiliates shall have absolutely no liability with respect to any claims made by third parties that your use of this product does not comply with applicable laws, rules and regulations and any resulting claims brought against you by third parties alleging non-compliance with such laws, or otherwise violates any third party's intellectual property, personal, privacy or proprietary rights as a result of your use of the product. We are also not responsible to you for any liability whatsoever resulting from your use, and/or installation of this product, and/or any loss of any recordings or footage.

Limited Warranty: Please check the in-box materials for more information about the limited warranty that pertains to your product.

Installation: This product should NOT be installed outdoors. You are solely responsible for the proper installation of this product. **To the extent permitted by law, Canon Inc. and its affiliates shall have absolutely no liability to you with respect to any damages or liabilities associated with the improper use of, or the installation of this product, or for any personal injuries sustained by you or any third parties as a result of any such improper**

use or installation of this product, whether or not the installation of this product was by you, or by any third party.

Privacy:

- Do not install this product in areas where people have a reasonable expectation of privacy, including but not limited to, bedrooms, dressing rooms, locker rooms and rest room facilities.
- Some jurisdictions require signage disclosing the existence of camera equipment. Please check your own area's laws for requirements.
- Making audio recordings is heavily regulated and can vary significantly by area. Please check laws in your jurisdiction before making any audio recordings.

OTHER IMPORTANT INFORMATION: Please see other important information pertaining to the use of this product by reading our User Manual, which can also be found at global.canon/ncsp, prior to using this product.

Trademarks

- Microsoft, Windows and Microsoft Edge are trademarks or registered trademarks of Microsoft Corporation in the United States and other countries.
- Windows is legally recognized as the Microsoft Windows Operating System.
- macOS is a trademark of Apple Inc., registered in the United States and other countries.
- Safari is a trademark of Apple Inc.
- IOS is a trademark or registered trademark of Cisco in the U.S. and other countries and is used under license.
- The terms HDMI, HDMI High-Definition Multimedia Interface, HDMI Trade dress and the HDMI Logos are trademarks or registered trademarks of HDMI Licensing Administrator, Inc.
- NDI is a trademark or registered trademark of Vizrt NDI AB in the United States and other countries.
- All other company or product names used in this document are trademarks or registered trademarks of their respective holders.



Software License Agreement

For the software license agreement, refer to the text file provided with the software and installer.

Except as expressly permitted by the law in effect in the jurisdiction in which you are located, you shall not reverse engineer the firmware which is contained in this product ("Firmware") and you shall not modify the Firmware. TO THE FULL EXTENT PERMITTED BY APPLICABLE LAW, IN NO EVENT SHALL EITHER CANON, OR CANON'S LICENSORS BE LIABLE FOR ANY DAMAGES WHATSOEVER ARISING OUT OF USING THE FIRMWARE. The Firmware may contain third party software components. Notwithstanding anything contained herein to the contrary, the terms and conditions of such third party software components shall be applied to your usage of the Firmware.

Third Party Software

This camera contains third party software modules. Confirm each module's license conditions in [System] > [Maintenance] > [General] > [Tool] > [See Third Party Software License Conditions] on the Settings Page.

This product partly contains software of which the source code is provided in accordance with the license.

- (1) Please access <<https://global.canon/en/oss/scd/index.html>> to fill the request form so that you receive an email with the URL to download the source code; or
- (2) Please send us a letter in writing with the following information, so that you receive the source code via postal mail. In case you have chosen this (2), WE MAY CHARGE YOU no more than the cost of performing this distribution.
 - (i) Your Address (Country/Region, ZIP code, Address, Your name) [mandatory]
 - (ii) Your e-mail address (for the purpose of possible communication with us) [optional]
 - (iii) Product Name/Application Name [mandatory]

(iv) Product/Application Software Version [optional]

If you do not specify a version, we will send source code corresponding to the latest version.

– Address:

Open Source Promotion Division, Canon Inc.

30-2, Shimomaruko 3-chome, Ohta-ku, Tokyo 146-8501, Japan

– Please see Privacy Notice at Canon Global

<<https://global.canon/en/oss/scd/privacy-notice.html>>.

This product is licensed under AT&T patents for the MPEG-4 standard and may be used for encoding MPEG-4 compliant video and/or decoding MPEG-4 compliant video that was encoded only (1) for a personal and non-commercial purpose or (2) by a video provider licensed under the AT&T patents to provide MPEG-4 compliant video. No license is granted or implied for any other use for MPEG-4 standard.

THIS PRODUCT IS LICENSED UNDER THE AVC PATENT PORTFOLIO LICENSE FOR THE PERSONAL USE OF A CONSUMER OR OTHER USES IN WHICH IT DOES NOT RECEIVE REMUNERATION TO (i) ENCODE VIDEO IN COMPLIANCE WITH THE AVC STANDARD ("AVC VIDEO") AND/OR (ii) DECODE AVC VIDEO THAT WAS ENCODED BY A CONSUMER ENGAGED IN A PERSONAL ACTIVITY AND/OR WAS OBTAINED FROM A VIDEO PROVIDER LICENSED TO PROVIDE AVC VIDEO. NO LICENSE IS GRANTED OR SHALL BE IMPLIED FOR ANY OTHER USE. ADDITIONAL INFORMATION MAY BE OBTAINED FROM MPEG LA, L.L.C. SEE

[HTTP://WWW.MPEGLA.COM](http://www.mpegla.com)

This product comes with exFAT, a licensed file system technology from Microsoft.

Nur für Europäische Union und EWR (Norwegen, Island und Liechtenstein)

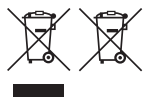

Diese Symbole weisen darauf hin, dass dieses Produkt gemäß WEEE-Richtlinie (2012/19/EU; Richtlinie über Elektro- und Elektronik-Altgeräte), Batterien-Richtlinie (2006/66/EG) und nationalen Gesetzen zur Umsetzung dieser Richtlinien nicht über den Hausmüll entsorgt werden darf.

Falls sich unter dem oben abgebildeten Symbol ein chemisches Symbol befindet, bedeutet dies gemäß der Batterien Richtlinie, dass in dieser Batterie oder diesem Akkumulator ein Schwermetall (Hg = Quecksilber, Cd = Cadmium, Pb = Blei) in einer Konzentration vorhanden ist, die über einem in der Batterien-Richtlinie angegebenen Grenzwert liegt.

Dieses Produkt muss bei einer dafür vorgesehenen Sammelstelle abgegeben werden. Dies kann z. B. durch Rückgabe beim Kauf eines neuen ähnlichen Produkts oder durch Abgabe bei einer autorisierten Sammelstelle für die Wiederaufbereitung von Elektro- und Elektronik-Altgeräten sowie Batterien und Akkumulatoren geschehen. Der unsachgemäße Umgang mit Altgeräten kann aufgrund potenziell gefährlicher Stoffe, die generell mit Elektro- und Elektronik-Altgeräten in Verbindung stehen, negative Auswirkungen auf die Umwelt und die menschliche Gesundheit haben.

Durch Ihre Mitarbeit bei der umweltgerechten Entsorgung dieses Produkts tragen Sie zu einer effektiven Nutzung natürlicher Ressourcen bei.

Um weitere Informationen über die Wiederverwertung dieses Produkts zu erhalten, wenden Sie sich an Ihre Stadtverwaltung, den öffentlich rechtlichen Entsorgungsträger, eine autorisierte Stelle für die Entsorgung von Elektro- und Elektronik-Altgeräten oder Ihr örtliches Entsorgungsunternehmen oder besuchen Sie www.canon-europe.com/sustainability/approach/.

Zusatzinformationen für Deutschland:

Dieses Produkt kann durch Rückgabe an den Händler unter den in der Verordnung des Elektro- und Elektronikgerätegesetzes beschriebenen Bedingungen abgegeben werden.

Als Endbenutzer und Besitzer von Elektro- oder Elektronikgeräten sind Sie verpflichtet:

- diese einer vom unsortierten Siedlungsabfall getrennten Erfassung zuzuführen,
- Altbatterien und Alttakkumulatoren, die nicht von Altgerät umschlossen sind, sowie Lampen, die zerstörungsfrei aus dem Altgerät entnommen werden können, vor der Abgabe an einer Erfassungsstelle vom Altgerät zerstörungsfrei zu trennen,
- personenbezogener Daten auf den Altgeräten vor der Entsorgung zu löschen.

Die Bedeutung von dem Symbol der durchgestrichenen Abfalltonne auf Rädern finden Sie oben in dieser Beschreibung.

Die Vertreiber von Elektro- oder Elektronikgeräten haben die Pflicht zur unentgeltlichen Rücknahme von Altgeräten. Die Vertreiber haben die Endnutzer über die von ihnen geschaffenen Möglichkeiten der Rückgabe von Altgeräten zu informieren.

Per l'Italia, Etichettatura ambientale: per il corretto riciclo degli imballaggi dei nostri prodotti e articoli, visita il sito <https://www.canon-europe.com/sustainability/approach/packaging>

-India only-

This product is not to be disposed of with your household waste. This product should be handed over to a designated collection point. For more information regarding return and recycling of WEEE products, please visit <https://in.canon/en/consumer/web/e-waste> or write to us at cipl.ewaste@canon.co.in

Also, this product including its components, consumables, parts and spares complies with the "E-Waste (Management) Rules, 2022" and prohibits use of lead, mercury, hexavalent chromium, polybrominated biphenyls or polybrominated diphenyl ethers in concentrations exceeding 0.1 % by weight and 0.01 % by weight for Cadmium, except for the exemptions set in Schedule II of the Rules.

Types of User Manuals

The following describes the different types of user manuals.

Important Information (included)

Explanation on safety precautions and downloading information from the Canon website.

User Manual (this document)

Explanation on procedures for installing and connecting the camera, settings on the Settings Page, troubleshooting, and major specifications.

How to Use This Document

The assumed reading format of this document is on a computer screen.

■ Notes



- 1 Any unauthorized reproduction of this document is prohibited.
- 2 The contents of this document are subject to change without any prior notice.
- 3 This document has been prepared with the utmost attention to accuracy. If you have any comments, however, please contact a Canon sales representative.
- 4 Canon shall assume no liability for any outcome of using this product, notwithstanding items 2 and 3 above.

■ Software Screenshots

The software screenshots samples shown in this document are for illustration only. The screenshots may differ from the actual screens displayed.

Descriptions use sample screens when connected to the camera, with Windows 10 for the operating system and Google Chrome for the web browser.

■ Symbols Used in This Document

Symbol	Meaning
 Important	Cautions and restrictions. Make sure to read these carefully.
 Notes	Supplementary descriptions and reference information.

Names of Parts

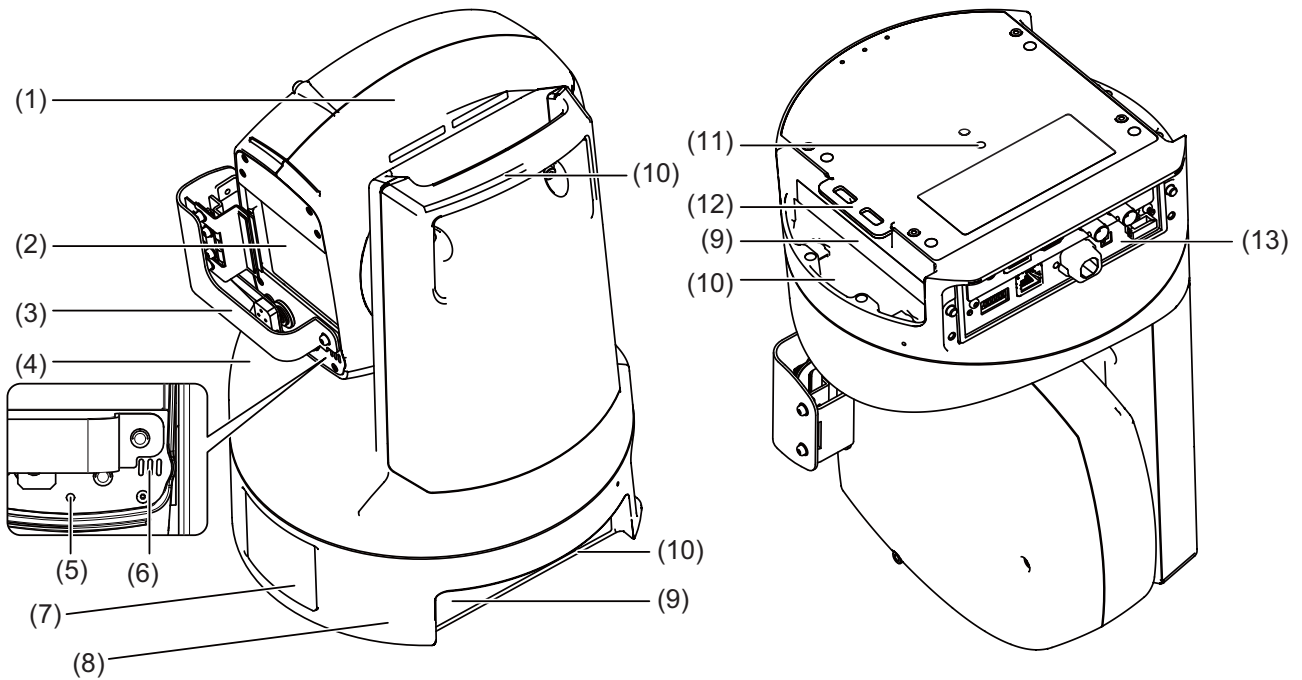

(1) Camera housing

(2) Lens protector

(3) Wiper

(4) Pan-tilt head

(5) Tally lamp

Red light is on during streaming. Lights are off when preparing for streaming (P. 31) or not streaming.

(6) Microphone

(7) Logo plate

(8) Base

(9) Rating label (x2)

(10) Handle (x3)

Refer to "Carrying the Product" (P. 20).

(11) Screw hole for tripod

(12) Through hole for safety wire

(13) Receptacle unit

Receptacle Unit

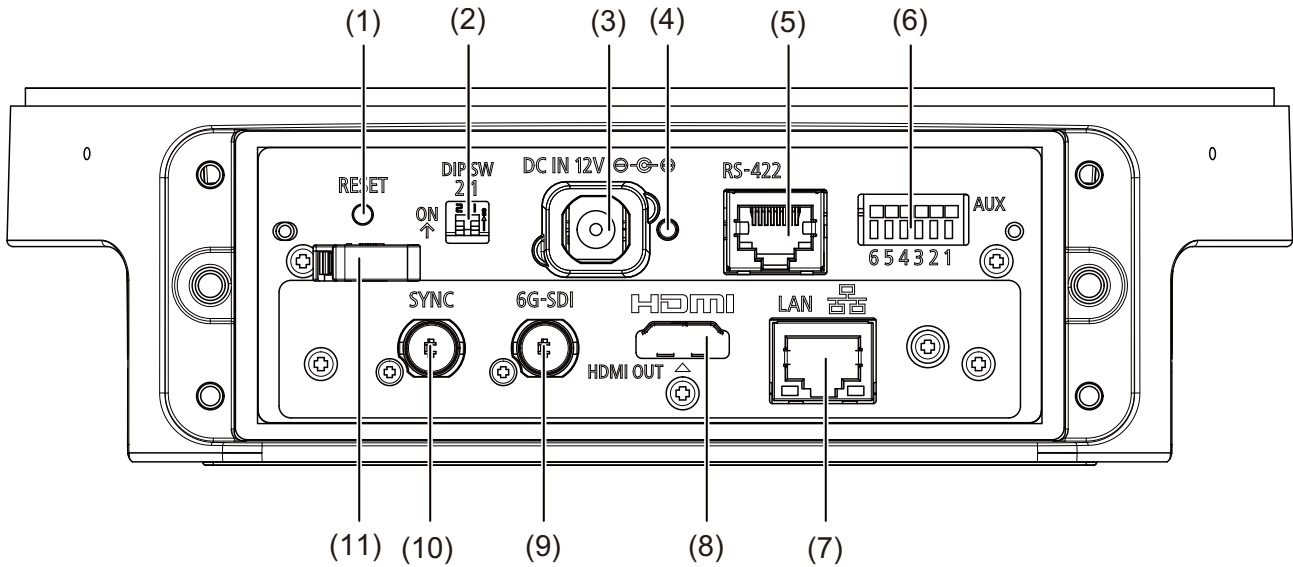

(1) RESET switch

Reset the camera settings to factory defaults.
For details, refer to "Restoring to the Factory Default Settings" (P. 106).

(2) DIP SW (switch)

Operation of the RESET switch for Add-On applications is changed using switch number 1. Frame frequency of the output video is changed using switch number 2 (factory default settings).

Frame frequency

59.94 Hz	<input type="checkbox"/>
50.00 Hz	<input type="checkbox"/>

(3) DC IN 12V terminal

Input terminal of the DC power supply. Use the included power cable to connect to the power supply. The black line with white indication line is +, and just the black line is -. Connect to the power supply that meets the installation site requirements (approved products and the environment) and product specifications. In addition, note that inrush current may cause the power supply to be insufficient and cause failure when power is turned on. Therefore, it is recommended to use a power supply with a power capacity of two to three times the rated capacity or more. For the power supply, refer to "Others" (P. 112).

Important

- Use the included power cable when using the DC power supply or AC adapter.
- The terminal has a block part to prevent incorrect insertion. Ensure the power cable is fully inserted into the terminal, and the POWER lamp blinks (green).
- The incorrect insertion prevention block part is designed to have a little room for play so that it can move. This is not a defect.

(4) POWER lamp

Lamp status	Status
Green light ON	Power ON
Green light BLINKING	Initializing (launching, restarting) Changing to or from standby
Orange light ON	Standby Insufficient power
Orange light BLINKING	Pan/Tilt position error Firmware being updated Device failure/Error

(5) **RS-422 Terminal**

Serial terminal (RJ-45 connector) supporting for RS-422.
Connect GND to each other to stabilize the voltage level of the signal.
Use category 5e or higher STP cables.

Pin number	Function	
1	TX-	Output (-)
2	TX+	Output (+)
3	RX-	Input (-)
4	GND	-
5	GND	-
6	RX+	Input (+)
7	NC	-
8	NC	-

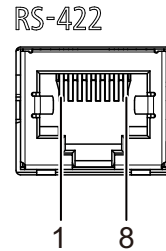

(6) **AUX (auxiliary) terminal**

Control terminal for external devices. Usable wire is AWG 28 to AWG 22, stripping wire length 9 to 10 mm.
When connecting with other device outdoors, use cables up to 3 m in length.

Number	Signal
1	ACC. CONT (open drain)
2	+12 V output (350 mA or less)
3	AUX OUT (3)
4	AUX OUT (4)
5	GND
6	AUX IN

Terminal for washer

To connect to a washer (commercially available), use ACC.CONT (open drain) and + 12 V output (350 mA or less) terminal.

Output terminal for external device

The external device output terminals consist of one set of two terminals (AUX OUT (3), AUX OUT (4)). There is no distinction between + and - for terminals. By controlling the internal controller, the conduction state and the insulation state between the two terminals can be switched. An optical coupling element is used for the output terminal, and it is separated from the internal circuit of the main unit.

Keep the connection load within the following ratings for the output terminal.

Rating between output terminals: DC maximum voltage 50 V

Continuous load current 200 mA

Input terminal for external device

The input terminal for external device consists of one set of two terminals (AUX IN and GND), and the GND terminal is connected to GND inside the main unit.

An interrupt is generated to the internal controller by connecting a cable to the AUX IN and GND terminals and electrically connecting (ON) or insulating them (OFF).

Connect the sensor or switch to a terminal that is electrically isolated from the power supply or GND.

Internal connection diagram

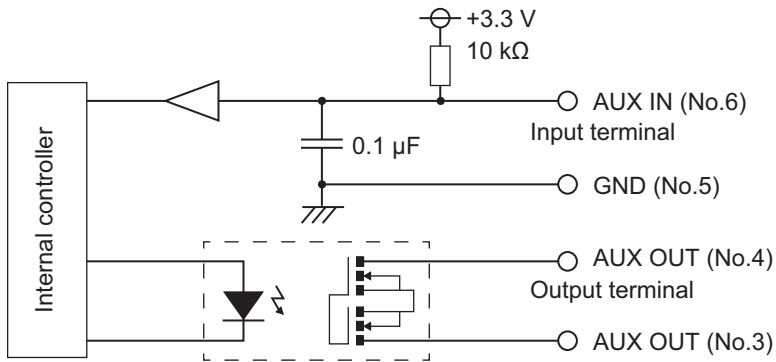

(7) LAN terminal

Terminal (RJ-45 connector) for network connections.

With PoE++ (Power over Ethernet++) capability, it is possible to provide power to the camera from the PoE++ supported hub which compile IEEE802.3bt Type 2 through a LAN cable.

Use an STP (shielded) type LAN cable with a length of 100 m or less and with a category 5e or more. Use a category 5 or less cable may reduce the power supply capacity.

Important

- Some PoE++ supported hubs can limit power usage on each port, however doing so may cause failure to operate correctly. In this case, do not limit power usage on any port.
- Other PoE++ supported hubs can limit the total power consumption of each port, however using multiple ports doing so may fail to operate correctly. Refer to the instruction manual of the PoE++ supported hub for use.

(8) HDMI OUT terminal

Terminal for HDMI output. Take necessary measures to prevent the cable from coming off, such as using a commercially available cable retaining part.

(9) 6G-SDI terminal

Output terminal (BNC connector) for uncompressed digital video and digital audio.

(10) SYNC terminal

Input terminal (BNC connector) for the external synchronization signal.

(11) Cable clamp

A cable clamp to prevent the power cable from coming off. Thread the cable to prevent it from coming off.

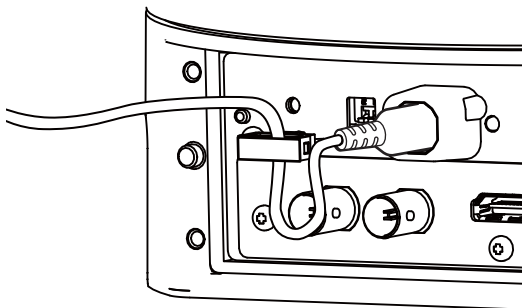

Note

- The camera does not have a power switch. Turn on/off the power by connecting/disconnecting the power cable or LAN cable or using the switch of the device that supplies power.
- If power is supplied from both DC power and PoE++, power from DC power has a priority. If the power supply is stopped from DC power while power is supplied from both DC power and PoE++, power supply to the camera will be stopped. In this case, disconnect the LAN cable to stop power supply from PoE++, reconnect the cable and restart, and power will be supplied again.

Examples of System Configuration

System Layout

This camera can be used by connecting with the following devices.

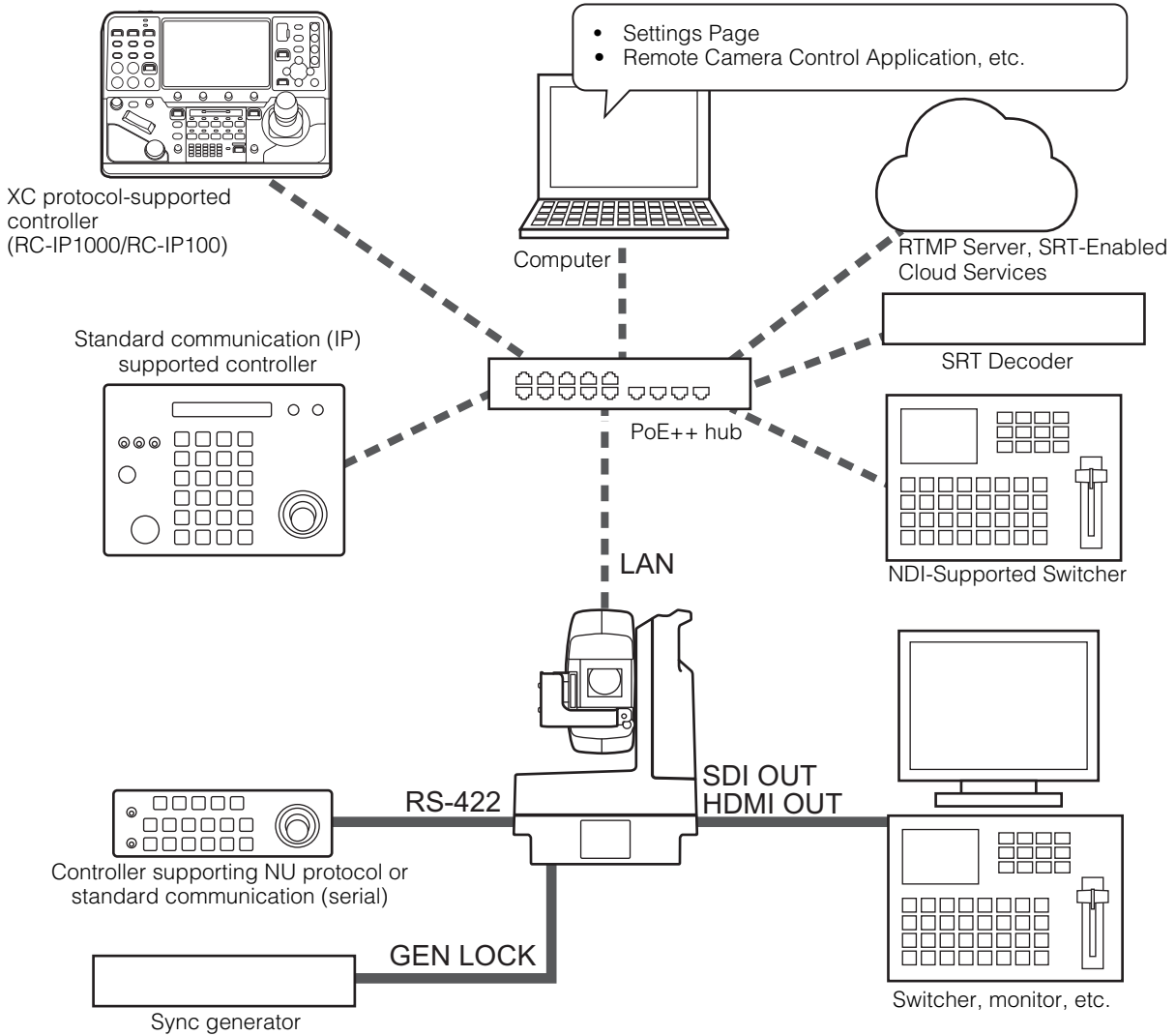

System Layout Example 1

The following is an example of a connection in which a network connected controller controls a camera and outputs SDI.

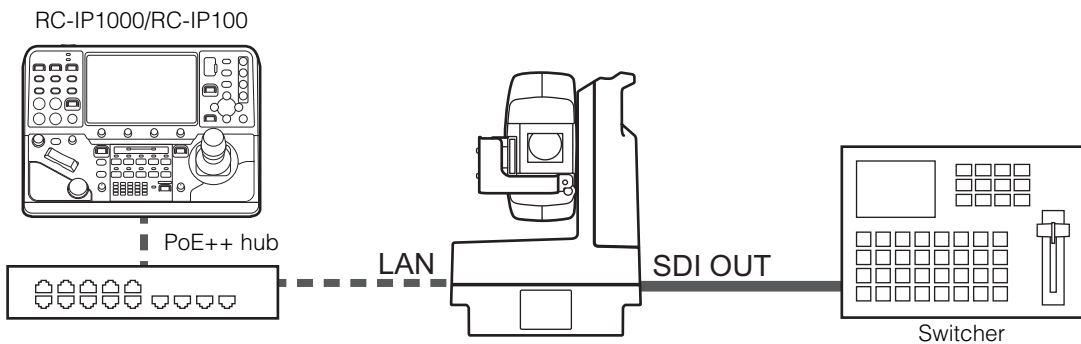

■ System Layout Example 2

The following is an example of network connected camera control using application.

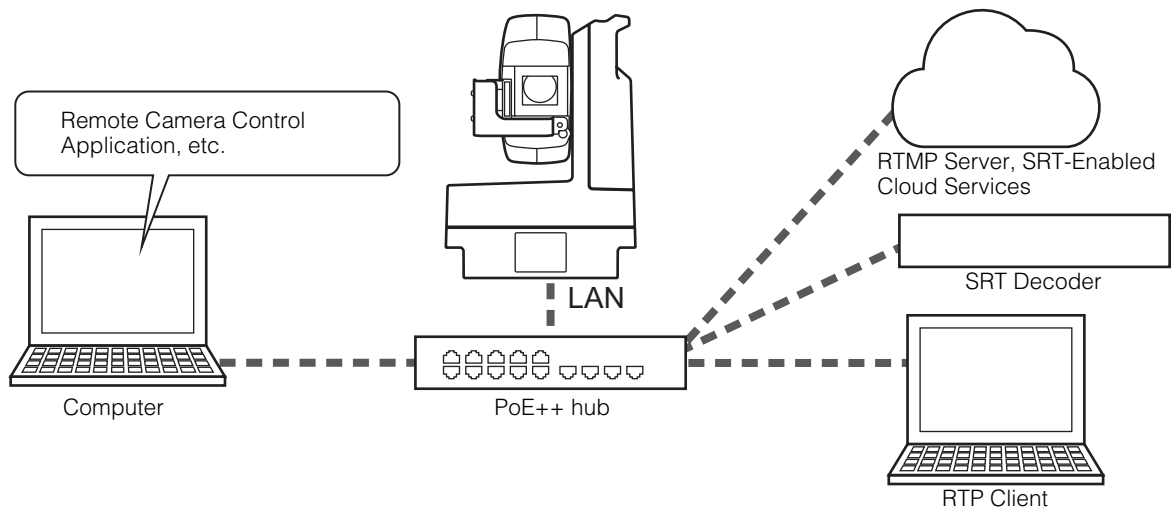

■ System Layout Example 3

The following is an example with no network connection. Even if network communication is not used during shooting, it is necessary to connect to the network beforehand and perform the initial settings from the computer.

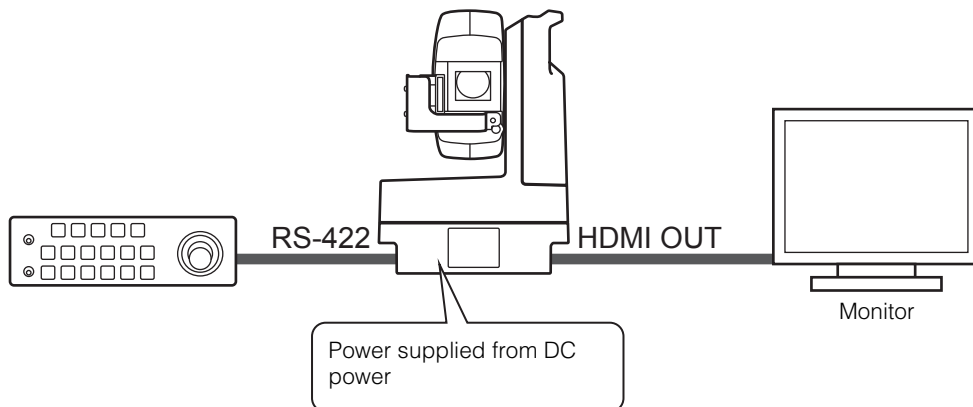

Chapter 1

Installation and Connection

This chapter explains the procedure for installing and connecting the camera and daily maintenance.

Installation

Carrying the Product

When carrying the product, hold the upper handle (1) or hold the two lower handles (2) simultaneously.

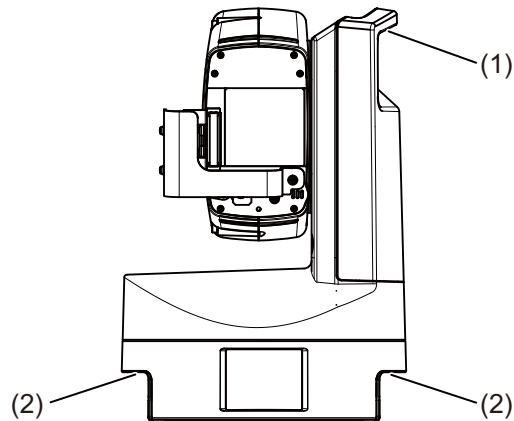

Mounting the Head Unit

Prepare a bracket matching the dimensions of the four M6 taps on the bottom surface.

Use steel screws with a bolt length equivalent to the bracket thickness + 15 to 20 mm, and fix it by tightening torque of 2 to 4.9 N · m (20 to 50 kg · cm).

Use a level to check that the base is horizontal.

■ Installation in a High Place

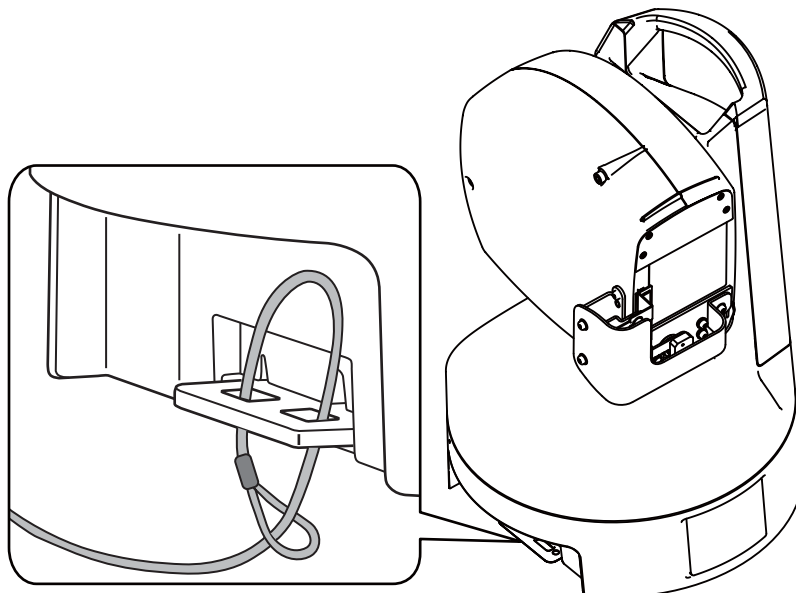

When there is a risk of falling, such as installation in a high place or mounting on the ceiling, be sure to insert a commercially available safety wire that can withstand the total weight including the camera and mounting bracket through the two through-holes and secure the wire to a sturdy structure.

■ Ceiling Mount

Do not use the screw holes for tripod but use the mounting bracket to install the camera.

When installing the product outdoors using a pole, etc., to prevent rain and bird damage, prepare mounting brackets of $\varnothing 290 \pm 5$ mm (mounting brackets of larger than $\varnothing 300$ mm will be captured) matching the dimensions of the four M6 taps on the bottom surface.

The logo plate can be turned upside-down. Pull up gently the right and left sides of the logo plate to pull it out, rotate it and push it back into place.

Using a Tripod

Attach the tripod by fixing a screw to the screw hole for tripod.

Use 1/4-20UNC screws and tighten them securely, and set the tripod on a flat surface with no steps.

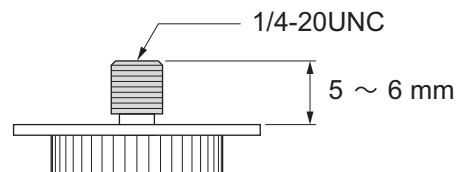

Attaching the Connector Cover

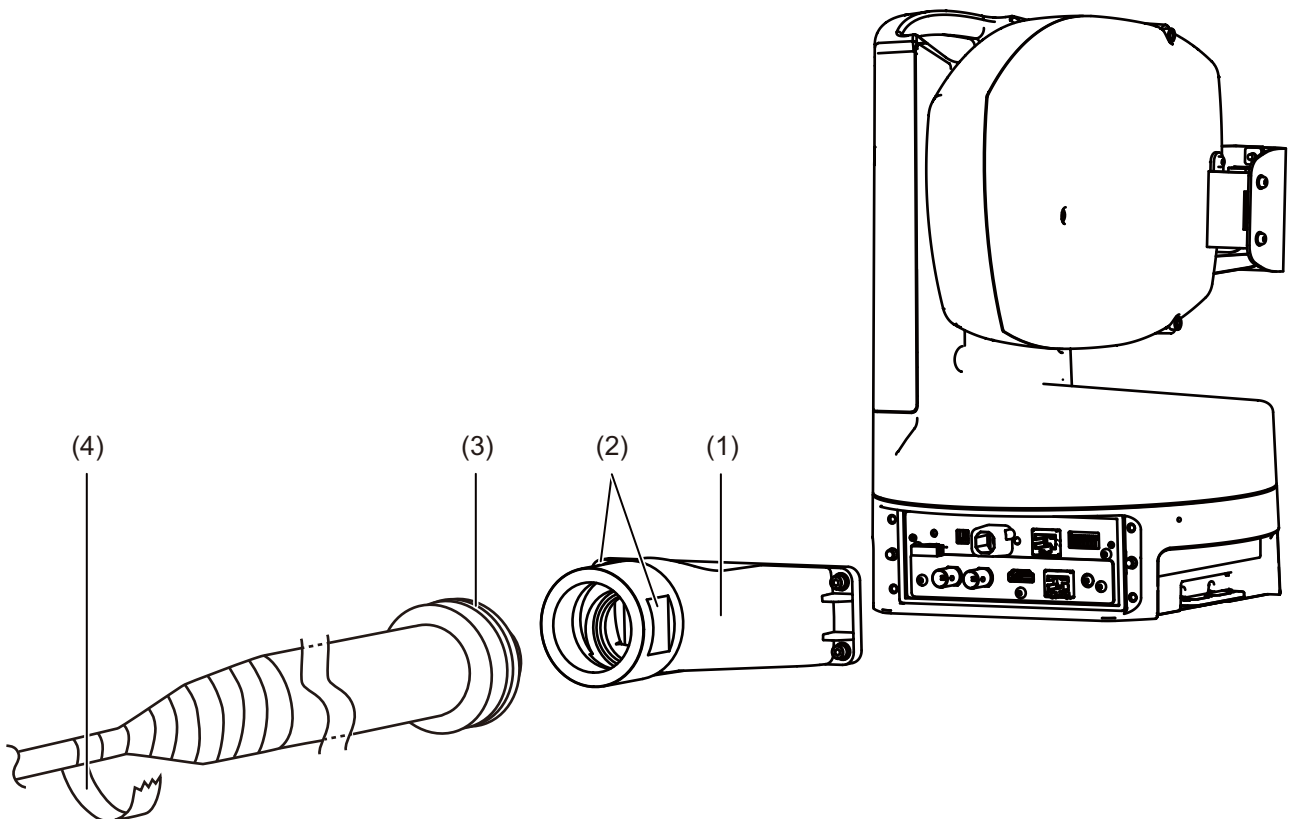

■ Preparation before Attaching

- Thread each cable through the connector cover (1).
- Connect each cable to each connector on the receptacle unit. Make sure that the cables are securely attached so that they will not come off. Use a cable clamp for the power cable (P. 16). For HDMI cable, if necessary, use a cable retaining part to take measures to prevent it from disconnecting.
- If not using an IP connection, configure the control protocol.
- Take necessary measures against lightning damage.

■ Attaching

- Connector cover
Attach the connector cover to the receptacle unit and affix it securely with four screws.
- Protecting cover
Prepare a commercially available cable protecting cover (3) which opening fits the M50 (screw length is 20 mm or shorter).
In mounting the protecting cover, hold two cuts on both sides of the cover (2) to avoid giving stress to the resin part of the cover.
Put the self-welding tape (4) firmly around the end of the protecting cover so that there is no space between the cable and the cable hose.

Protecting cover (recommended)

Made of metal

Manufacturer: SANKEI

Model: KMBM 42 (Connector for knockout)

KUU 42 (Hose, KEIFLEX)

Made of resin

Manufacturer: Flexa

Model: RQG48-M50 (RohrFlex connector)

FS-M 50 (Gasket for RohrFlex)

Routine Maintenance

Confirmation of Video Image

Regularly check to make sure the set capture area is not misaligned, and is still in focus.
If necessary, re-adjust the product.

Cleaning Method

Before beginning any work, turn off the power.

■ Cleaning the External Cover and Lens Protector

- 1** Wash off foreign substances such as dust and sand using clean water.
If the connector cover is not attached, wipe with a soft cloth dampened with clean water as it cannot be washed away directly with water.
- 2** If the lens protector is dirty with something that cannot be removed with water, such as fingerprints or oil, gently wipe the lens protector clean with a soft sponge or cloth dampened with a neutral dishwashing detergent diluted to approximately 1% with water.
- 3** Wipe them clean with a soft cloth that has been dampened with clean water to ensure that water droplets and detergent do not remain.



Important

By performing an incorrect cleaning method, the external cover or lens protector could become scratched and will need to be replaced for a fee. Therefore, follow the next set of instructions carefully.

- Because of dust, dirt, or fingerprints etc., the auto focus may not work properly or the reflection of backlight or infrared light may cause the image to become white and cloudy. In order to preserve the level of image quality, regular cleaning is necessary.
- Do not wipe with a dry cloth. Never wipe with a cloth especially without removing the attached grime. This may result in scratches to the external cover or lens protector.

Chapter 2

Default Settings

It describes the preparation and settings after installing the camera.

Security Checking/Settings

The security function of the OS or web browser may block the settings and operation of the camera. Check the security settings beforehand, and change the settings if required.

Checking the Firewall Settings (Windows)

To use the software on a computer with Windows Defender Firewall enabled, it is necessary to add each piece of software as an application that allows communication through the firewall.



Note

If applications were not added in this procedure, they can still be added as allowed applications in the [Windows Security Alert] dialog that appears when starting the software.

- 1** Click [Windows Defender Firewall] in [Control Panel] > [Systems and Security].
- 2** Click [Allow an app or feature through Windows Defender Firewall].
- 3** Click [Change Settings] > [Allow another app].
- 4** Select [CameraSearchTool.exe] downloaded from the website, and click [Add].

Initial Camera Settings

In order to use the camera, it is necessary to first connect the computer to the camera via network then complete the initial setup, including setting the Administrator Account.

This section explains how to use the Camera Search Tool and how to open the camera's initial settings screen directly on a web browser. Use the Multi-Camera Management Application to perform the initial settings for multiple cameras. For details, refer to the Multi-Camera Management Application User Manual.

Note

Even if you have not configured the initial settings, HDMI/SDI video is output and can be used for simple operation checks and other tasks as long as a LAN cable is not connected.

Settings Using the Camera Search Tool

Use the Camera Search Tool to access the camera's initial settings screen and perform the initial settings for factory-set cameras.

Camera detection by this tool is valid only for cameras in the same network.

- 1 Connect the camera to the computer on the same network, then turn on the power.
- 2 Double-click the Camera Search Tool icon downloaded from the website.



Windows: CameraSearchTool.exe
macOS: Camera Search Tool.app

When starting this tool, cameras on the same network are automatically detected and the acquired information is displayed in a list.

In the case the camera is not automatically detected, click [Search Camera].

Note

- Even if the network addresses of the computer and the camera are different, if IPv6 of the computer is enabled, the camera will be detected using the IPv6 link-local address.
- If IPv6 is not available, either assign an IPv4 address on the DHCP server or use the AutoIP feature to detect the camera. To use the AutoIP function, make the following settings, and connect the computer and camera to a network environment without a DHCP server. Each computer and camera will be assigned an IPv4 link-local address of 169.254.xxx.xxx and will belong to the same network, so the camera can be detected.

Windows: set the computer to [Automatically obtain IP address] in the Windows network settings.

macOS: [System Preferences] > [Network], then set [IPv4 Settings] to [Use DHCP server].

- 3 Click the IP address of the camera to be set up.

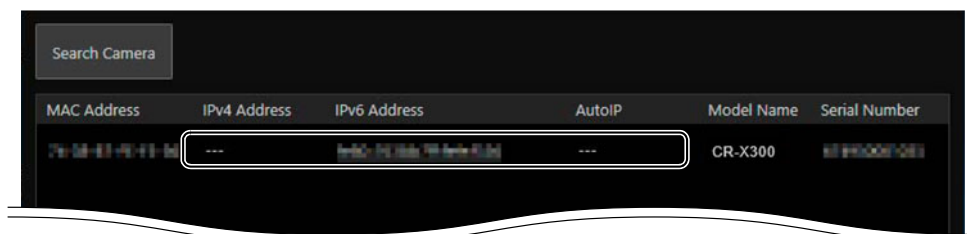

The web browser starts and the [Default Settings (1/2)] screen of the camera is displayed.

- 4 Enter the Administrator Name and Administrator Password, select [Language], and click [Apply and Reboot].

After rebooting the camera, the user name and password input dialog is displayed.



Important

To ensure system security, set the administrator password that should not be easily guessed by third parties. Be sure not to forget the new password.

- 5 Enter the user name (administrator name) and password (administrator password), and click [OK].

The [Default Settings (2/2)] screen of the camera is displayed.

- 6 Set the [Frame Frequency (Hz)], [Network], and [Date and Time], then click [Apply] or [Apply and Reboot].

After the camera reboots, the Settings Page is displayed and settings are able to be configured.

If the [Network] settings are changed, the camera may be unable to be connected from the operating web browser. In this case, check the connection with computer according to the set network settings, and then reconnect.

For details on the settings, refer to "System Settings" (P. 54).



Note

The video size and frame rate options for the output video are determined according to the set frame frequency.

- 7 Repeat steps 3 to 6 to initialize multiple cameras.

To exit the Camera Search Tool, click [Exit] in the menu or click the **X** button on the screen.

Camera's Settings Page from the Web Browser

Able to access the camera by directly specifying the IP address from a web browser.

If there is an IP address assigned by the DHCP server, specify it, otherwise specify "192.168.100.1".

Important

- Able to access with the IP address of 192.168.100.1 approximately two minutes after connecting the camera to the network environment.
- If an IPv4 address is assigned by the DHCP server, it will switch to that address and access by 192.168.100.1 will not be possible.
- If there is device with 192.168.100.1 on the same network, the same IP address will be assigned, and access to the camera with 192.168.100.1 will not be possible.

1 When accessing with 192.168.100.1., set the IP address of the computer.

Set the IP address of the computer to the same network as 192.168.100.1 such as 192.168.100.xxx.

2 Launch the web browser.

3 Enter the camera's IP address in the address column of the web browser and press [Enter].

The [Default Settings (1/2)] screen of the camera is displayed.

4 Perform steps 4 to 6 of the previous section "Settings Using the Camera Search Tool".

After the camera reboots, the Settings Page is displayed and settings are able to be configured.

Note

If necessary, restore the computer settings changed in step 1.

Chapter 3

Camera Setup

The settings required to use the camera are made on the Settings Page. Before starting operation, make various settings on the Settings Page according to the shooting conditions and purpose. There are also menus that can be performed during operation, such as camera maintenance.

Overview

Follow the steps below to connect to cameras to display the Settings Page.

Accessing from a Web Browser

Enter the IP address set in "Initial Camera Settings" (P. 26) directly into the web browser to display the Camera's Settings Page.

Generally, the Settings Page is accessed using a guest user account. For details on the user authority settings, refer to "User Authority" (P. 77).

Important

- In the case the Administrator Account is forgotten, return settings to factory default settings (P. 106). However, because the Administrator Account and other settings will be initialized, it will no longer be able to connect to the camera as it is. Use the Camera Search Tool to configure the default settings.
- To ensure security, close the web browser after completing the settings using the Settings Page.
- Do not open multiple Settings Pages at one time and try to change the settings of a single camera.

- 1** Launch the web browser.
- 2** Enter the IP address and press Enter.

Configuration of the Settings Page

The configuration of the Settings Page is as follows:

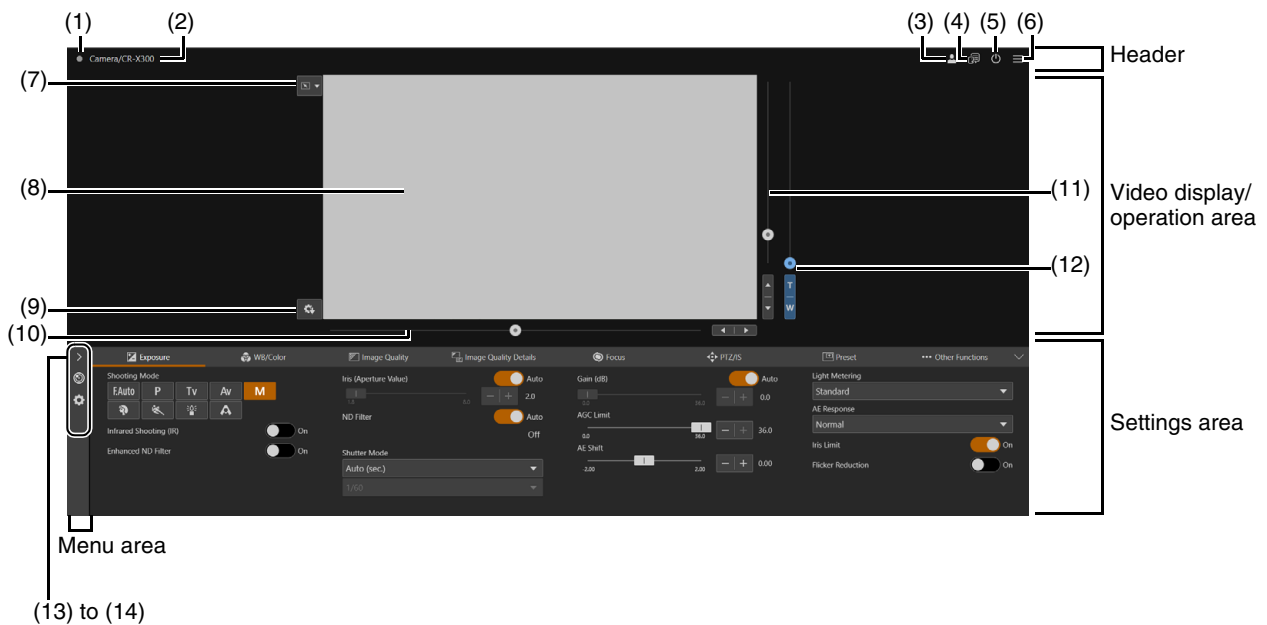

Settings area (When [Camera Control] is selected)

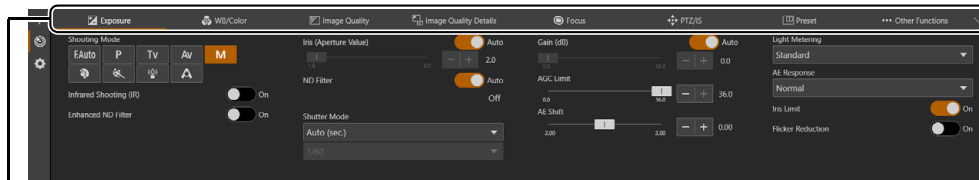

(16) to (22)

■ Header

This area is common to all Settings Pages.

(1) Tally Lamp Status Display

Displays the video distribution status with the Tally Lamp.

■: Distributing

■: Preparing for distribution

■: No distribution

(2) Camera Name / Model Name

Displays the camera name and the model name of the connected camera.

(3) Switch Account

Switch the account used to access the camera. To access the camera as a guest, check [Guest User].

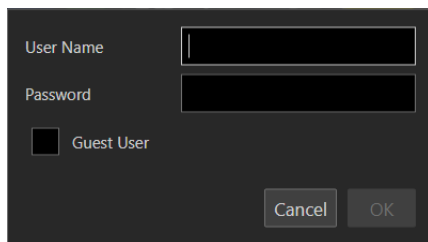

(4) Select Language

Set the language to be displayed on the Settings Page

(5) Power ON/Standby

Switches between the camera on and standby mode. Set it to standby mode if needing to stop HDMI/SDI output or IP distribution of videos.

If  is clicked while the camera is on, "This will switch to standby. Do you want to continue?" message will appear. Click [OK] and "On Standby" will appear in the video display area and will go into standby mode. Click [Start Up] to return to the power on state.

The Status of the camera can be confirmed by the POWER lamp at the rear of the camera (P. 14).

(6) Menu

Click to display a list of items in the settings area.

For details of the items, refer to "Settings area" (P. 32).

When using an account without camera control privileges, only [Video] and [System] can be selected. If [Video] is selected, the settings area and operation area are not displayed (only the video display area is displayed).

■ Video display/operation area

Displays the video received from the camera. Also, operates the pan, tilt, and zoom of the camera.

(7) Click Operation Menu

Select the operation performed when clicking on the video display area. Available operations will differ depending on the camera settings.

 [Pan/Tilt]: operates the camera angle (P. 34)

 [Focus]: focus related operations such as moving the focus frame or tracking (P. 46, P. 47).

 [Off]: no operation.

(8) Video Display Area

JPEG video is displayed.

When the image cannot be displayed, the  Reconnect button appears in the center of the screen.

(9) Save Preset

Save to preset 1 camera settings such as camera angle, exposure. The image at the time of preset registration is saved as a thumbnail.

(10) Pan Slider (P. 34)

Move the camera angle left or right. Use the ◀ or ▶ button to fine-tune the position.

(11) Tilt Slider (P. 34)

Move the camera angle up or down. Use the ▲ or ▼ button to fine-tune the position.

(12) Zoom Slider (P. 34)

Move up to zoom in (telephoto) or down to zoom out (wide angle).

Use the T or W button to fine-tune the position.

■ Menu Area

Display camera settings and shooting assistance function setting items on the settings area, or configure system settings. Click  and select a menu, or click each icon to switch the displayed menu.

(13) [Camera Control] menu

Sets camera related settings.

(14) [System] menu (P. 54)

Configure advanced camera system settings such as video and audio, server, communications, and security.

If this tab is clicked, the video display/operation area disappears, and the screen will be configured with the setting item category and the settings screen.

■ Settings area

Change camera settings. Click each tab to switch the settings area.

(15) [Exposure] tab (P. 36)

Sets exposure settings.

(16) [WB/Color] tab (P. 41)

Setting the white balance and color matrix settings.

(17) [Image Quality] tab (P. 43)

Setting the image quality.

(18) [Image Quality Details] tab (P. 44)

Sets advanced image quality settings.

(19) [Focus] (P. 46)

Sets focus settings.

(20) [PTZ/IS] tab (P. 49)

Sets pan, tilt, and zoom operations and image stabilizer settings.

(21) [Preset] tab (P. 50)

Sets the preset settings.

(22)  [Other Functions] tab (P. 53)

Sets the color bar output and Add-On settings.









Important

Do not use the [Back] and [Forward] buttons on the Web browser to navigate through the settings page. The changed settings may be reverted or unintended changes may be applied.



Note

- By clicking  at the right of the tab area, the Settings area will be hidden, and only the video display/operation area will be displayed.
It will be reverted by clicking .
- If the width of the screen is narrow, tabs can be switched by using the   buttons. Also, for each Settings area, it is possible to switch the display by using the   buttons at the bottom of the screen or by clicking .

Camera Operation

Set the camera angle by operating the camera's pan, tilt and zoom.

Note

Camera control by clicking and dragging does not guarantee exact precision.

Operation by Clicking on the Video Display Area or by Slider

Click and Drag Operation

When the click operation is set to [Pan/Tilt], if you click on the video display area, the camera angle moves so that the position of the mouse pointer is at the center. Also, dragging on the video display area operates the pan/tilt of the camera.

If a single click or drag does not result in the desired camera angle, repeat the operation.

Slider Operation

Dragging the pan and tilt slider knobs pans and tilts the camera.

Drag the zoom slider knob to operate the zoom.

The slider knob moves even if clicking the slider on the point without the knob.



Fine tune the pan, tilt, and zoom positions by clicking the ◀ or ▶, ▲ or ▼, or T or W buttons.

■ Slider Operation When Using the Digital Zoom and Digital Tele-Converter

When [PTZ/IS] > [Digital Zoom] is set to [400x], the digital zoom area is displayed on the zoom slider and digital zoom operation is enabled.

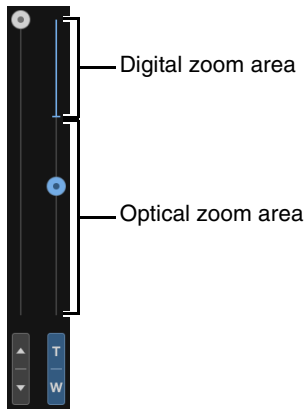

When [PTZ/IS] > [Digital Zoom] is set to [Digital Tele-Converter] (P. 49), the video is magnified according to the magnification selected, but the position of the slider does not change.

Exposure Settings

Settings for the shooting mode according to the shooting environment and subject, as well as the iris, shutter speed, and gain.

To display the [Exposure] tab, select the [Camera Control] menu to the left of the settings area.

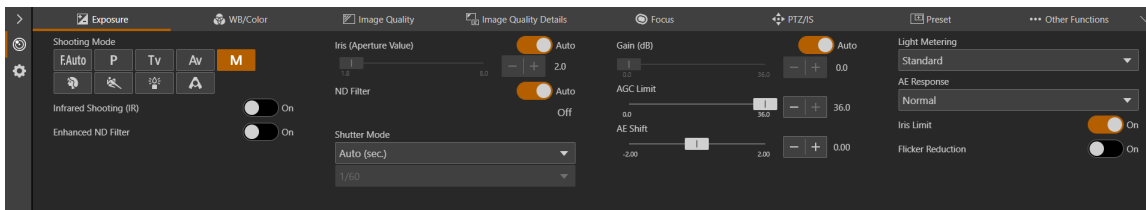

[Shooting Mode]

Switches the shooting mode according to the shooting environment and subject.

FAuto (Full Auto)

The exposure (iris, shutter speed, gain, etc.) and white balance settings are adjusted automatically.

P (Program AE)

The exposure (iris, shutter speed, gain, etc.) settings are adjusted automatically. It is possible to set [AGC Limit], [AE Shift], [Metering Mode], and [AE Response].

Tv (Shutter Priority AE)

The shutter speed is adjusted manually. The gain and iris are adjusted automatically.

Av (Iris Priority AE)

The iris is adjusted manually. The shutter speed and gain are adjusted automatically.

M (Manual Exposure)

The exposure (iris, shutter speed, gain, etc.) is adjusted manually.

Portrait

Blurs the background to make the subject stand out.

Sports

Captures fast moving subjects.

Low Light

Brightly captures subjects in dark locations.

Spotlight

Captures subjects illuminated by a spotlight beautifully.

Note



- In **Portrait**, **Sports**, **Low Light**, and **Spotlight**, the exposure (iris, shutter speed, gain, etc.) settings are adjusted automatically.
- In **Portrait** and **Sports**, the captured video may not appear smooth or may flicker.
- For precautions regarding shooting in **Tv** (Shutter Priority AE) and **Low Light**, refer to "About Shooting with Slow Shutter" (P. 40).

- The items that can be set differ depending on the shooting mode. The details are shown below.

○: Items which can be set

●: Items which are set automatically

–: Items which cannot be set

Item	Shooting Mode					 
	F.Auto	P	Tv	Av	M	
Infrared* ¹	○	○	○	○	○	○
Enhanced ND filter	○	○	○	○	○	○
Iris	●	●	●	○	○	●
ND Filter	●	○* ²	○* ²	○* ² * ³	○* ² * ³	●
Shutter Mode	●	●	○* ⁴	●	○	●
Gain	●	●	●	●	○	●
AGC Limit	–	○	○	○	○* ⁵	–
AE Shift	–	○	○	○	○* ⁶	–
Metering Mode	–	○	○	○	○* ⁶	–
AE Response	–	○	○	○	○* ⁶	–
Iris Limit	○	○	○	○	○	○
Flicker Reduction	○	○	○	○	○	○
Auto Slow Shutter	○	○	–	–	–	–

*1 When set to [On], shooting mode cannot be set.

*2 Switching to [Auto] or off only.

*3 Linked to the iris settings.

*4 Possible to set the shutter speed.

*5 Possible to set only when gain is [Auto].

*6 Possible only if one of Iris, Shutter Mode and Gain is set to [Auto].

[Infrared]

Select whether to perform infrared shooting. In infrared shooting, since the near-infrared light sensitivity is higher compared to normal shooting, it is possible to shoot brightly even the dark scenes.

Note

- When the infrared is [On], the following items cannot be set.
 - [Exposure] > [Enhanced ND Filter], [Iris (Aperture Value)], [ND Filter], [Shutter Mode], [Gain (dB)], [AGC Limit], [AE Shift], [Metering Mode], [AE Response], [Iris Limit]
 - [WB/Color]
 - [Image Quality]
 - [Image Quality Details]
 - [Focus] > [Face Detection AF], [AF Speed]
- When the infrared is [On] in manual focus, the focus will be fixed once in auto focus, then return to manual focus.
- Depending on the light source, auto focus may not function properly during zoom operation.
- Because of the significantly increased near-infrared sensitivity in infrared shooting, no strong light or heat source should be turned toward the lens when switching to infrared shooting.

[Enhanced ND Filter]

Select whether to use the enhanced ND filter. The enhanced ND filter allows to open the aperture for a video with shallow depth of field even in a bright environment. This is also convenient for avoiding blur caused by narrowing down the aperture.

Note

In infrared shooting, the [Enhanced ND Filter] is fixed to off.

[Iris (Aperture Value)]

Adjusts the iris (aperture) according to the brightness of the subject.

When [Auto] is set, the iris is automatically adjusted.

When [Auto] is off, the iris can be manually adjusted. Moving the slider to the left opens the aperture and brightens the video. Moving it to the right narrows the aperture and darkens the video.

Following aperture values can be set.

F1.8, F2.0, F2.2, F2.4, F2.6, F2.8, F3.1, F3.4, F3.7, F4.0, F4.4, F4.8, F5.2, F5.6, F6.2, F6.7, F7.3, F8.0, Closed*

* When the Iris is set to manual and the [Iris Limit] is off.



The aperture value that can be set differs depending on the zoom position. Reference aperture value is displayed on the screen.





Maximum wide angle: F1.8 to F8.0, maximum telephoto: F2.8 to F8.0

Note





- To make the subject stand out by changing the depth of field and blur the background or surroundings, set a smaller aperture value , and to keep everything from close objects to far-away objects in focus, set a larger aperture value.
- When shooting in a bright location, narrowing down the iris can cause blurring. It is possible to prevent blurring by adjusting the ND filter and shutter speed and opening the iris.
- When [AUTO] of the iris is set to off, the aperture value from Auto will be retained. The aperture value before setting to [AUTO] will not be restored.
- In infrared shooting, iris is fixed open.

[ND Filter]

When the [Shooting Mode] is set to  (Iris Priority AE) or  (Manual Exposure) and the [Iris (Aperture Value)] is F4.0 or larger, ND filter is automatically adjusted linked to the setting of the iris and its value will be displayed. In other shooting modes, when [Iris (Aperture Value)] is F4.0 or larger, the exposure is automatically adjusted using the ND filter.

In  (Iris Priority AE),  (Manual Exposure),  (Program AE), or  (Shutter Priority AE), in order to adjust the exposure without using the ND filter, [Auto] can be set to off.

Note

- When the [Shooting Mode] is set to  (Full Auto),  (Portrait),  (Sports),  (Low Light), or  (Spotlight), ND filter is always automatically adjusted.
- The displayed value reflects the effect of the enhanced ND filter.
- In infrared shooting, ND filter cannot be set.

[Shutter Mode]

Adjusting the shutter speed enables to adapt to the subjects and the shooting environment, making it possible to capture fast-moving subjects (sports, vehicles, etc.) clearly and brighten low-light scenes, etc. Shutter speed can be adjusted in the following modes:

[Auto (sec.)]

Automatically adjusts the shutter speed according to the brightness of the video.

[Speed (sec.)]

Sets the shutter speed to seconds. The shutter speed can also be set to a value higher than the frame rate.

[Slow (sec.)]

Sets the shutter speed slower than the frame rate to seconds. This setting is used for shooting in low-light areas.

Also, special effects such as "blurring the background" and "adding residual image effects to zoom" are available for shooting a moving subject with pan operation.

For precautions when shooting in slow, refer to "About Shooting with Slow Shutter" (P. 40).

[Clear Scan (Hz)]

Sets the shutter speed by frequency. This is used to reduce black bands on the screen and flickering from fluorescent lighting, or to fine tune the brightness.

[Angle (°)]

You can set the shutter angle to determine the shutter speed.

The shutter speed that can be selected differs depending on the frame frequency.

Shutter Mode	Frame Frequency (Hz)				
	23.98	29.97	59.94	25.00	50.00
Auto (sec.)	1/24 - 1/2000	1/30 - 1/2000	1/60 - 1/2000	1/25 - 1/2000	1/50 - 1/2000
Speed (sec.)	1/24 - 1/2000	1/30 - 1/2000	1/60 - 1/2000	1/25 - 1/2000	1/50 - 1/2000
Slow (sec.)	1/6, 1/12	1/8, 1/15	1/8, 1/15, 1/30	1/6, 1/12	1/6, 1/12, 1/25
Clear Scan (Hz)	23.98 - 250.38	29.97 - 250.38	59.94 - 250.38	25.00 - 250.40	50.00 - 250.40
Angle (°)	360°, 240°, 180°, 120°, 90°, 60°, 45°, 30°, 22.5°, 15°, 11.25° Angles equivalent to 1/120 sec., 1/100 sec., 1/60 sec., 1/50 sec., 1/40 sec., 3/100 sec., 1/30 sec. and 1/25 sec. can also be set.				

Note

- When the [Shooting Mode] is set to **Tv** (Shutter Priority AE), the shutter speed value can be set as follows according to the frame frequency.
 - At 23.98, 25.00, or 50.00 Hz: 1/6 to 1/2000 sec.
 - At 29.97 or 59.94 Hz: 1/8 to 1/2000 sec.
- In infrared shooting, shutter speed cannot be set.

[Gain (dB)]

Able to set the amplification amount of the video amplifier.

When [Auto] is set, the gain is automatically adjusted. By setting the [AGC Limit], the maximum gain can be limited.

When [Auto] is off, the gain can be manually adjusted. The adjustment range is 0.0 to 36.0 dB (by 0.5).

Note

- Increasing the gain may cause a slightly grainy screen. Also, uneven colors, white dots, and vertical lines may appear on the screen.
- In infrared shooting, gain cannot be set.

[AGC Limit]

Able to suppress the occurrence of grainy screen, uneven colors, white dots, vertical lines, etc. by limiting the maximum value when the gain is set to [Auto].

The adjustment range is 0.0 to 36.0 dB (by 0.5).

Note

- When the shooting mode is **F.Auto** (Full Auto), the [AGC Limit] value will not be applied. It will be limited by the maximum value of 24.0 dB.
- In infrared shooting, AGC limit cannot be set.

[AE Shift]

When one of the [Iris (Aperture Value)], [Shutter Mode] or [Gain (dB)] is set to auto, the exposure can intentionally be compensated to capture subjects either at a brighter or darker exposure.

Move the slider to a negative value to darken the image, or to a positive value to brighten it.

Adjustment can be made in the range of -2 levels to +2 levels (by 0.25).

Note

In infrared shooting, AE shift cannot be set.

[Metering Mode]

When one of the [Iris (Aperture Value)], [Shutter Mode] or [Gain (dB)] is set to Auto, and the metering mode is set to match the shooting scene, it is possible to shoot with more appropriate brightness.

[Standard]

Meters the entire screen while focusing on the subject in the center of the screen.

[Backlight]

Controls darker areas of the screen more brightly when shooting backlight scenes.

[Spotlight]

Controls the brightness of the subject to be optimal in the spotlight.

Note

In infrared shooting, metering mode cannot be set.

[AE Response]

Select the response of AE when one of the [Iris (Aperture Value)], [Shutter Mode] or [Gain (dB)] is set to Auto. The set values are High, Normal, and Low in order of the shortest time to achieve the proper exposure.

Note

In infrared shooting, AE response cannot be set.

[Iris Limit]

By setting [Iris Limit] to off and iris to [Closed], the black balance can be adjusted under dark conditions.

Note

In infrared shooting, iris limit cannot be set.

[Flicker Reduction]

Setting [On] automatically detects and corrects flickering from fluorescent lights.

Note

- Erroneous flicker detection may cause horizontal noise. In this case, avoid using [Flicker Reduction].
- When the frame frequency is 23.98 Hz, the flicker reduction setting would not be effective.
- When shooting under an artificial light source such as a fluorescent lamp, mercury lamp, or halogen light, flicker may occur in principle depending on the shutter speed set. It may be possible to suppress flicker by setting the shutter speed according to the frequency of the power supply. For 50 Hz, select 1/50 second* or 1/100 second; for 60 Hz, select 1/60 second or 1/120 second.
* Not available depending on the frame frequency.

[Auto Slow Shutter]



When shooting in a place with insufficient light (such as a room with low light), slows down the shutter speed automatically and adjusts to make the video brighter.

Possible to set when the shooting mode is  (Full Auto) and  (Program AE).

Note

- The slowest shutter speed for each frame frequency differs as follows.
 - At 23.98 Hz: 1/12 sec.
 - At 29.97 Hz: 1/15 sec.
 - At 59.94 Hz: 1/30 sec.
 - At 25.00 Hz: 1/12 sec.
 - At 50.00 Hz: 1/25 sec.
- Auto slow shutter cannot be used under the conditions below.
 - When AGC limit is enabled
 - When frame frequency is 23.98 Hz, 29.97 Hz, or 25.00 Hz, and [Focus] > [Face Detection AF] is [Face Det. & Tracking] or [Face Only]
- For the precautions when shooting with auto slow shutter, refer to the following section "About Shooting with Slow Shutter".

■ About Shooting with Slow Shutter

By setting the [Shooting Mode] to  (Manual Exposure) or  (Shutter Priority AE) to set a slow shutter speed, setting it to  (Low Light), or setting the [Auto Slow Shutter] to [ON], it is possible to shoot the subject brightly even where the light is insufficient. However, depending on the scene or the subject, the following may occur.

- Noticeable residual image from moving subjects
- Deterioration of image quality
- White spots on the screen
- Autofocus not functioning well

WB/Color Settings

Setting the white balance and color matrix settings.

To display the [WB/Color] tab, select the [Camera Control] menu to the left of the settings area.

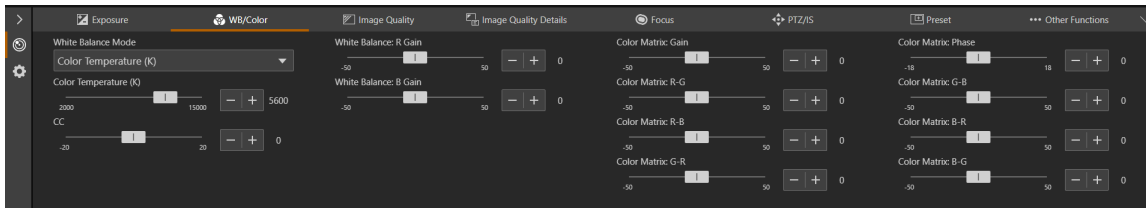

Note

- When [Exposure] > [Shooting Mode] is **F.Auto** (Full Auto), [White Balance Mode] is AWB fixed.
- When [Exposure] > [Shooting Mode] is **Portrait**, **Sports**, **Low Light**, or **Spotlight**, only [White Balance Mode] (AWB fixed), [Color Temperature (K)], and [CC] are displayed.
- When [Exposure] > [Infrared] is set to [On], [WB/Color] cannot be selected.

[White Balance Mode]

Sets white balance according to the color temperature of light sources such as illuminations and daylight. Adjustment procedure is as follows:

[AWB]

Adjust the white balance so that it is always optimal. The white balance is automatically adjusted as the color temperature of the light source changes.

[Daylight]

Sets the white balance according to the daylight (approx. 5600 K). The adjustment range is 4300 K to 8000 K. You can further adjust the color compensation* value (± 5 CC).

Adjusts the color along the green/magenta gradation.

[Tungsten]

Sets the white balance according to tungsten lighting (approx. 3200 K). Use this setting when shooting under tungsten or tungsten colored fluorescent lighting. The adjustment range is 2700 K to 3700 K. You can further adjust the color compensation value (± 5 CC).

[Color Temperature (K)]

Specify the color temperature in range of 2000 K to 15000 K to adjust the white balance. You can further adjust the color compensation value (± 20 CC).

[Manual]

Set [R Gain] and [B Gain] as desired.

[Set A], [Set B]

Captures the reference white color in the actual shooting environment.

Illuminate a gray card or white subject (white paper, etc.) with a light source and click [White Balance Calibration] while the subject fills the screen.

Possible to register two settings: [Set A] and [Set B].

The settings are erased after the camera is restarted or turned off/on, so register the settings as a preset in order to save them.

Note

- When shooting under the following conditions, if the screen color looks unnatural in [AWB], adjust the white balance using [Set A] or [Set B]:
 - Shooting in locations where lighting conditions suddenly change
 - Close-up shooting
 - Shooting a scene with only one color, such as sky, sea, or forest
 - Shooting under mercury lamps and certain fluorescent/LED lights
- If the setting is other than [AWB], and the location or brightness changes or the ND filter is switched, adjust the white balance again.
- Color temperatures are given for reference purposes only.

[White Balance:R Gain]

Adjusts the shift amount of the red tint in the white balance.

[White Balance:B Gain]

Adjusts the amount of blue tint shift in the white balance.

[AWB Response]

Selects the responsiveness when [White Balance] is set to [AWB].

The set values are High, Normal, and Low, in order of the shortest time required to achieve the proper white balance.

[Color Matrix:Gain], [Color Matrix:Phase], [Color Matrix:R-G], [Color Matrix:R-B], [Color Matrix:G-R], [Color Matrix:G-B], [Color Matrix:B-R], [Color Matrix:B-G]

The color matrix allows to fine-tune the tone of the video.

Settings	Adjustment Items
Gain	Color depth
Phase	Hue
R-G	Cyan to green and red to magenta color tones
R-B	Cyan to blue, red to yellow color tones
G-R	Magenta to red and green to cyan color tones
G-B	Magenta to blue and green to yellow color tones
B-R	Yellow to red, blue to cyan color tones
B-G	Yellow to green and blue to magenta color tones

Image Quality Settings



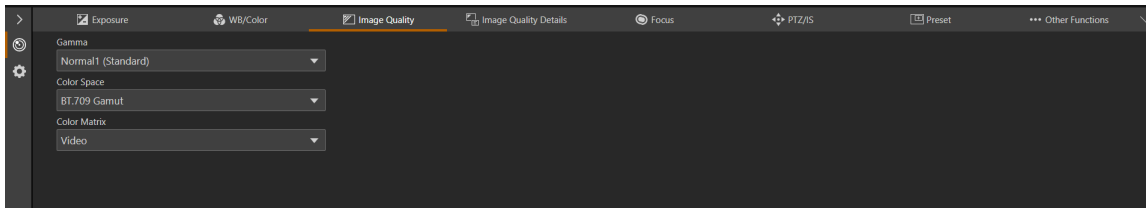

Setting the image quality.

To display the [Image Quality] tab, select the [Camera Control] menu to the left of the settings area.



Note

In the following cases, the [Image Quality] tab cannot be selected.

- When [Exposure] > [Shooting Mode] is  (Portrait),  (Sports),  (Low Light), or  (Spotlight)
- When [Exposure] > [Infrared] is set to [On]

[Gamma]

Select the gamma curve that determines the overall taste of the video.

[Normal 1 (Standard)]

Use when watching on a TV monitor.

[Normal 3 (BT.709)]

Able to express black gradation in the shadow areas more compared to Normal 1.

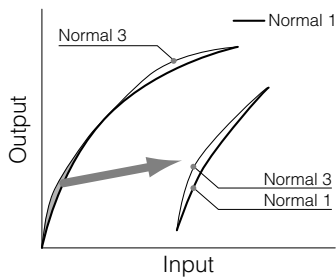

[Color Space]

Select a color space.

[BT.2020 Gamut]

A color space that conforms to the ITU-R BT. 2020 standard specified for UHDTV (4K/8K).
This is the setting for HDMI/SDI output.

[BT.709 Gamut]

A standard color space that conforms to the sRGB standard.

[Color Matrix]

Select a color tone for the video.

[Video]

Realizes color reproduction with contrast suitable for TV broadcasting.

[Neutral]

Faithful color reproduction.

Image Quality Details Settings

Detailed settings related to image quality.

To display the [Image Quality Details] tab, select the [Camera Control] menu to the left of the settings area.

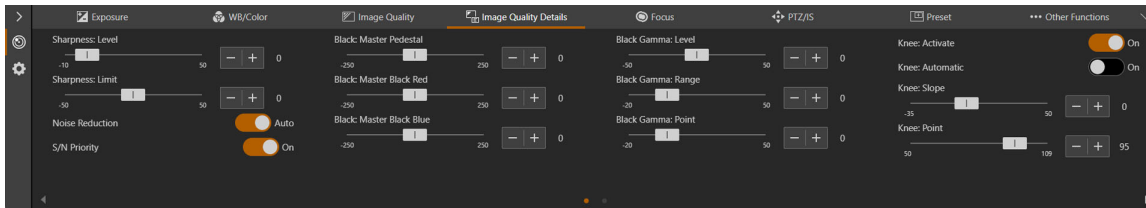

Note

In the following cases, the [Image Quality Details] tab cannot be selected.

- When [Exposure] > [Shooting Mode] is (Portrait), (Sports), (Low Light), or (Spotlight)
- When [Exposure] > [Infrared] is set to [On]

[Sharpness:Level]

Adjust the level of edge enhancement.

[Sharpness:Limit]

Adjusts the level at which the edge enhancement is limited.

[Noise Reduction]

Selects setting method of noise filter to reduce noise.

When [Auto] is turned on, the noise reduction level is automatically set.

When [Auto] is turned off, it is possible to adjust the noise reduction level manually. The higher the value, the greater the noise reduction effect.

[S/N Priority]

When [Noise Reduction] is set to [Auto] and [S/N Priority] is set to [On], the image quality is adjusted with the noise reduction prioritized.

Note

Depending on the scene, the entire screen may appear soft, or an afterimage may appear on a moving subject.

[Black:Master Pedestal]

Adjusts the black level.

The higher the value, the vivid the dark area will be and less contrast. Decreasing the number makes the black levels flat.

[Black:Master Black Red], [Black:Master Black Blue]

Corrects R and B individually for black color casts.

[Black Gamma:Level], [Black Gamma:Range], [Black Gamma:Point]

Corrects gamma in shadow areas. By changing each value, the gamma curve on the black side within the range shown in the figure below is adjusted.

- Level: Height from reference gamma
- Range: Width from the point
- Point: Vertex position

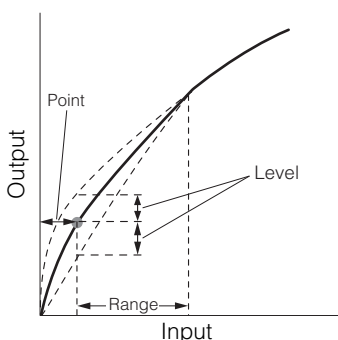

[Knee:Activate], [Knee:Automatic], [Knee:Slope], [Knee:Point], [Knee:Saturation]

Compresses the highlighted areas to suppress the occurrence of blown highlights.

- Activate: Enables knee adjustment.
- Automatic: Enables automatic knee adjustment.
- Slope: Indicates the slope of the knee.
- Point: Indicates the knee point.
- Saturation: Adjusts the color intensity in the highlighted areas.

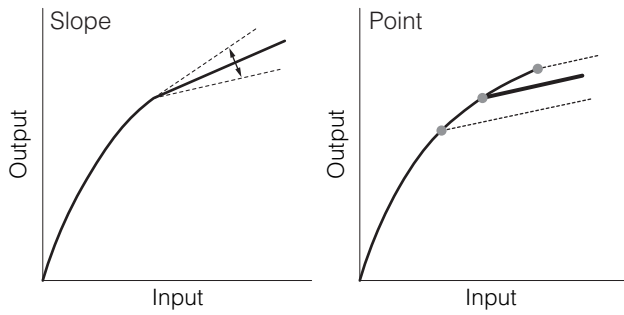

Focus Settings

There are two focus adjustment modes: "Autofocus" and "Manual focus".

Switch the [AF] on in the focus mode to select the autofocus or switch it to off to select the manual focus.

The items that can be set differ depending on the focus mode.

To display the [Focus] tab, select the [Camera Control] menu to the left of the settings area.

Autofocus

Autofocus adjusts the focus automatically.

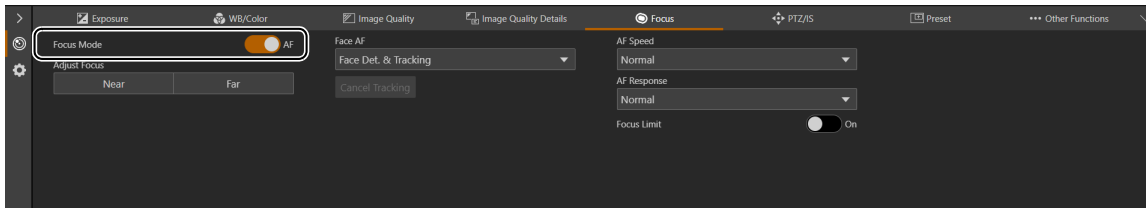

[Focus Mode]

Turning [AF] on switches to autofocus mode.

[Adjust Focus]

Possible to adjust the focus manually even when [AF] is set to on.

Click [Near] to move the focus position to the near side, and [Far] to move the focus position to the far side. Click and hold the button to move continuously. Release the button to achieve the focus automatically again.

[Face Detection AF]

Sets the operation of the face detection AF (the ability to detect and focus on a person's face).

[Off]

Focuses on the center of the screen. Face detection is not performed.

[Face Det. & Tracking]

Gives priority to focus on a person's face.

- When there is a person's face in the screen
When multiple people are in the screen, the main subject is automatically determined.
The following face frames are displayed.

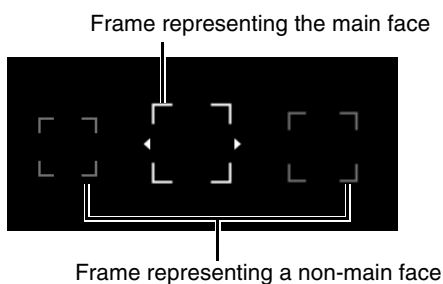

Click on a face frame to track that face (P. 47).

- When there is no face in the screen
Focuses on the center of the screen (P. 47).

[Face Only]

Focuses only on the person's face.

If there is a person's face in the screen, follows the procedure described in the previous section, [Face Det. & Tracking].

If there is no person's face in the screen, the focus is locked until a face is detected.

Note

In infrared shooting, the [Face Detection AF] is fixed to [Off].

[Cancel Tracking]

Cancels tracking when tracking a specified subject (P. 47).

[AF Speed]

Selects the autofocus adjustment speed.

[High]

Operates AF at the fastest speed. Effective for high brightness or night view. Uses the external sensor at the same time.

[Normal]

Operates more smoothly compared to [High]. Uses the external sensor at the same time.

[Low]

Stable AF operation.

Note

In infrared shooting, AF speed cannot be set.

[AF Response]

Selects the responsiveness of the autofocus.

The setting values are High, Normal, and Low in order of the shortest time until the focus operation starts.

[Focus Limit]

Reduces the time to achieve the focus by limiting the focus range.

When set to [On], the focus range is 60 cm (2 ft.) to ∞ (throughout the entire zoom range). When set to off, the range is 1 cm (0.39 in.; at full wide-angle) to ∞ , including the macro area.

■ Clicking on the Screen

By clicking on the person or on the subject in the screen, even if the subject moves, it is possible to continue to focus on as the main subject. This is called tracking.

When [Face Detection AF] is [Off]

The subject in the center of the screen stays in focus and the AF frame will not be displayed.

When [Face Detection AF] is [Face Det. & Tracking]

When clicking on a person's face, a tracking frame appears on the face, and the tracking will be in progress.

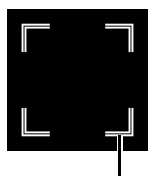

Tracking Frame

If something other than the face of a person is clicked, the tracking frame appears on the subject clicked in the screen and is tracked.

Note

When the tracking frame is displayed, the face frame will not be displayed.

When [Face Only] is selected for [Face Detection AF]

Clicking a person's face is the same as in [Face Det. & Tracking] in the previous section.

If something other than a person's face is clicked, the focus does not change.

Autofocus

- The focus position for autofocus varies slightly depending on the shooting conditions such as the subject, brightness, and zoom position. Check the focus again before shooting.
- Focus adjustment can take a while when the frame frequency is 29.97 Hz, 25.00 Hz, or 23.98 Hz.
- It may be difficult to focus with autofocus in certain cases.

Shooting conditions that are difficult to focus with autofocus

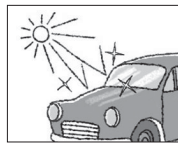

Strong light is reflected.

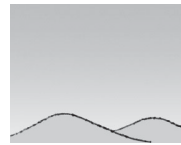

Center of the screen has little light/dark difference.

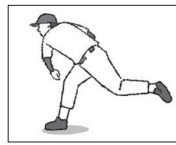

Fast movement

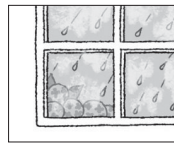

Shooting through glass with water droplets



Night view

- When the iris is narrowed down
- When the shutter speed is in the range of [Slow (sec.)]
- When subjects are at both far and near sides
- The following are the main examples of failure to detect faces:
 - When the face is extremely small, large, dark, or bright relative to the entire screen
 - When the face is facing sideways or diagonally, or upside down
 - When part of the face is hidden
- May detect a subject other than a person as a face by mistake. In such a case, set [Face Detection AF] to [Off].
- May accidentally track another subject with similar characteristics. In this case, select the subject again.
- The conditions under which face detection AF or tracking cannot be used are as follows:
 - In infrared shooting
 - Shutter speed slower than 1/30 sec. (frame frequency at 59.94/29.97 Hz), 1/25 sec. (at 50.00/25.00 Hz), or 1/24 sec. (at 23.98 Hz).
 - When [PTZ/IS] > [Digital Zoom] is set to [400x] and the image size is magnified by more than 80 times
 - When [PTZ/IS] > [Digital Zoom] > [Digital Tele-Converter] is set to [6.0x]

Manual Focus

In Manual Focus, the focus position is moved manually.

By clicking on the video display area, the focus is once automatically adjusted to the position of the mouse pointer that was clicked, and then returns to manual focus.

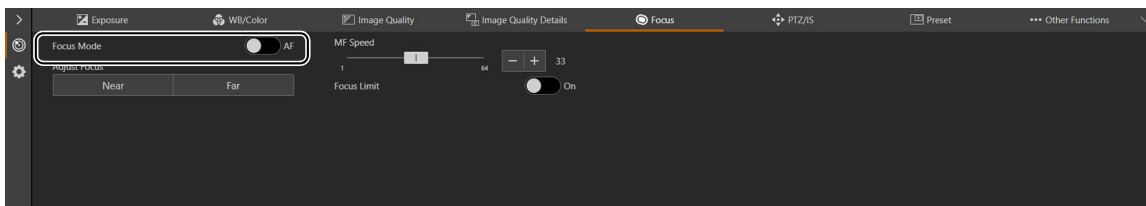

Note

- If a zoom operation is performed after focusing, the focus may shift.
- If the camera is left turned on, the focus may shift due to increase of the temperature of the lens and inside the camera body. Check the focus again before shooting.

[Focus Mode]

Turning [AF] off switches to manual focus mode.

[Adjust Focus]

Click [Near] to move the focus position to the near side, and [Far] to move the focus position to the far side. Click and hold the button to move continuously.

[MF Speed]

Selects the manual focus adjustment speed (amount of focus movement when [Near] or [Far] is clicked.).

[Focus Limit]

The setting is the same as for "Autofocus" (P. 46).

PTZ/IS Settings

Settings for the camera's pan, tilt, and zoom operations and image stabilizer.

To display the [PTZ/IS] tab, select the [Camera Control] menu to the left of the settings area.

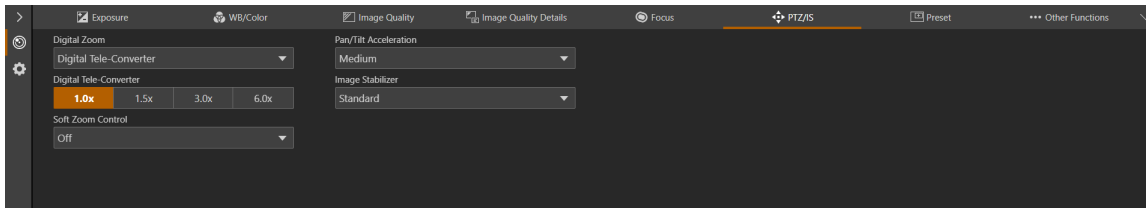

[Digital Zoom]

Select whether to use the digital zoom, or the Digital Tele-Converter.

[Digital Tele-Converter]

When [Digital Zoom] is set to [Digital Tele-Converter], select the magnification of the focal length.

Because the image is processed digitally, the video is coarser over the entire zoom range.

[Soft Zoom Control]

Slowly accelerates when zooming starts and decelerates when zooming stops.

[Pan/Tilt Acceleration]

Select the degree of acceleration of the pan/tilt operation.

[Image Stabilizer]

Select whether to use the function that reduces the blurring of videos caused by camera vibration.

[Standard] corrects relatively small blurs.

[Powered IS] corrects blurring during telephoto shooting. The closer the zoom is to the telephoto side, the greater the correction effect.

Note

- If the blurring is too large, it may not be corrected completely.
- When panning or tilting, the anti-vibration effect is smaller than when not operating.
- Swing back may occur when the pan or tilt stops.

Preset Settings

By registering preset camera settings such as camera angle, exposure, and image quality, it is possible to easily call the presets and execute the settings.

To display the [Preset] tab, select the [Camera Control] menu to the left of the settings area.

Registering Presets

- 1 Click the [Preset] tab on the Settings Page.
Displays the preset settings.
- 2 Click the preset number field to register, and click [Add].

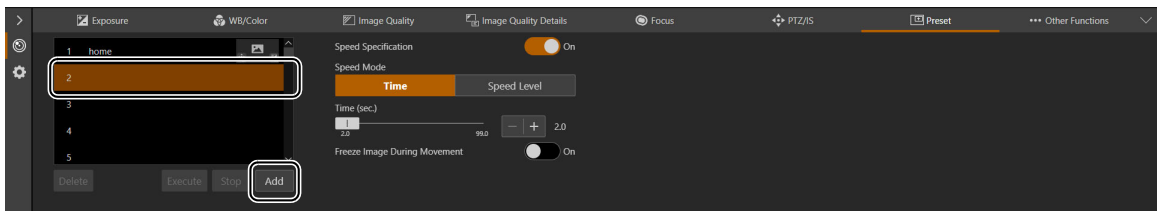

The settings screen will pop up.

- 3 Set the preset items and click [Add].

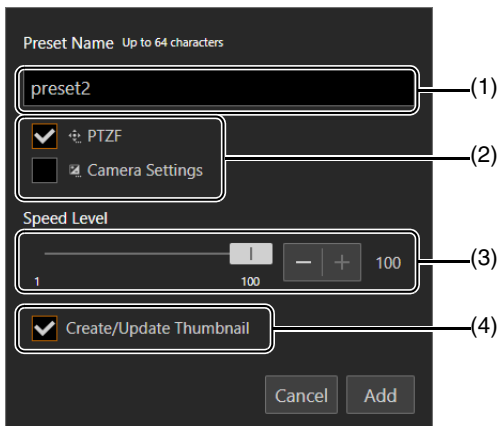

- (1) [Preset Name]
Enter a preset name.
- (2) [PTZF], [Camera Settings]
Check the items to preset.

Item	Preset target
PTZF	Pan/Tilt/Zoom position [Focus] [PTZ/IS] > [Digital Zoom], [Pan/Tilt Acceleration], [Soft Zoom Control]
Camera Settings	[Exposure] [WB/Color] [Image Quality] [Image Quality Details] [PTZ/IS] > [Image Stabilizer]

- (3) [Speed Level]
Sets the pan/tilt speed and zoom speed for a registered preset.

(4) [Create/Update Thumbnail]

Displays the image at the time of registration in the preset list as a thumbnail. Uncheck this check box if you do not need to display thumbnails, or if you do not wish to update thumbnails when a preset is edited.

The preset is saved to the camera and displayed in the list as follows:

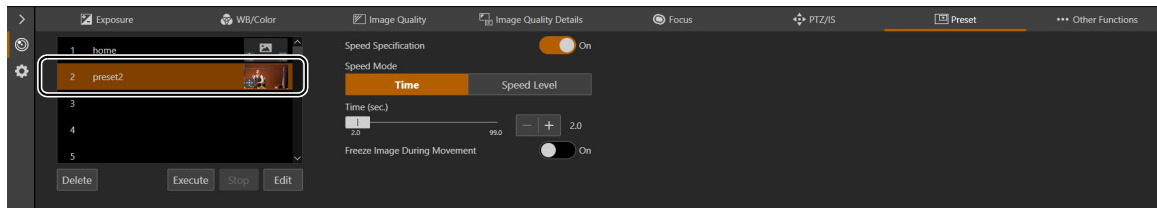

The  icon at the bottom of the thumbnail means that the presets include a PTZF setting.

 means that the presets include a camera quality setting.

For presets with unregistered thumbnails, the following icon is displayed.

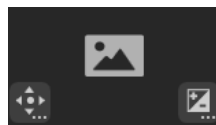

4 Repeat steps 2 to 3 to register multiple presets.

Note

- [home] is the setting when the camera was launched (home position). It can be overwritten but cannot be deleted.
- Able to register up to 100 presets (including home position) in the camera.
- If the thumbnail is not updated when a preset is edited, the displayed thumbnail may differ from the actual preset state.

Calling Presets and Speed Specification

Select the preset to call from the list and click [Execute] to reflect the preset settings on the camera.

Confirm in the video display area. You can also set the display method shown during preset movement.

The speed at which the camera moves to the pan/tilt/zoom position can be specified as the one set when registering the preset or a different one.

1 Select the preset to call from the list and set [Speed Specification] to either off or [On].

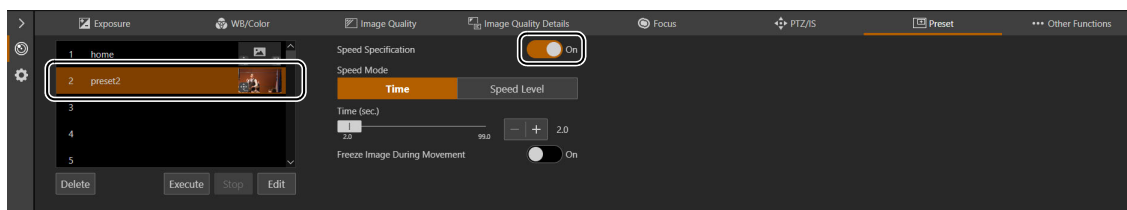

Set [Speed Specification] to off to use the speed level set when registering the preset.

If set to off, continue from step 3.

If set to [On], continue from step 2.

2 Select [Speed Mode] > [Time] or [Speed Level] and adjust the value using the slider.

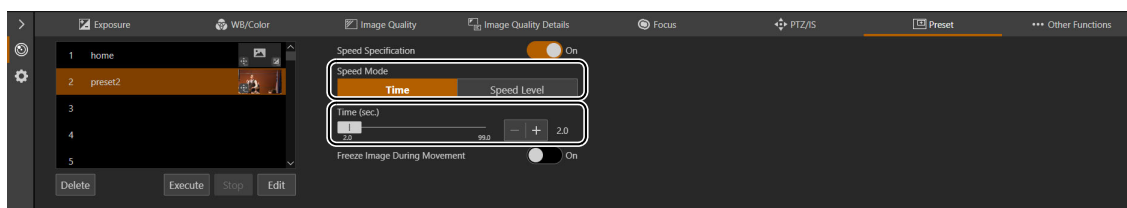

If you specify a speed that differs from the one set when registering the preset, select [Time] or [Speed Level].

3 Set [Freeze Image During Movement].

If set to [On], you can display a still image of the video (set at the time movement starts) during preset movement. You can also change the default value (P. 81).

4 Click [Execute].

The camera moves to the pan/tilt/zoom position at the speed specified in step 1 or 2.

Note

- If the pan/tilt/zoom or focus of the camera is operated while a preset is running, the preset stops. However, another preset can be called while a preset is running.
- If [Stop] is clicked while a preset is running, the preset stops.
- Depending on the relationship between the pan/tilt/zoom position before the call and the registered pan/tilt/zoom position, and the [Time] setting, it may not operate within the set time.
- Camera settings other than the pan/tilt/zoom position are reflected immediately when [Execute] is clicked.
- Presets cannot be called while the washer is in operation. Call the preset after the washer operation stops.
- If you perform one of the following operations when a still image is being displayed, the displayed image returns to the normal video display.
 - Changing the HDMI/SDI signal output format (video size/frame rate, mapping) settings.
 - Turning color bars on.
- If you input a sync signal to the GEN-LOCK terminal and execute a preset before synchronization is stabilized, still images will not be displayed.

Deleting Presets

Select the preset to delete from the list and click [Delete] to delete it from the camera.

Other Functions Settings

Performs color bars output, output to external devices, and operation of wiper and washer (sold on the market). To display the [Other Functions] tab, select the [Camera Control] menu to the left of the settings area.

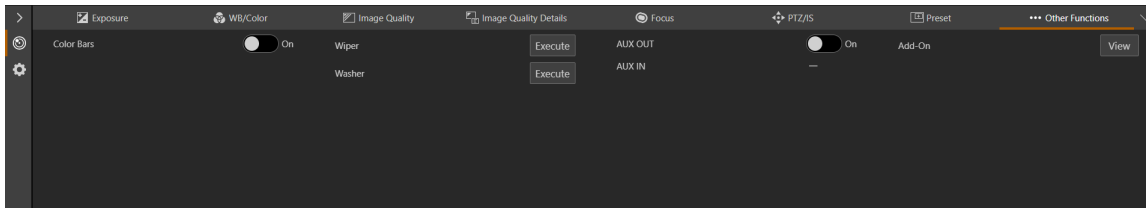

[Color Bars]

Outputs color bars for adjustment of color and brightness of the external monitor. Set the types of color bars in [System] > [System] > [Camera] > [Color Bar Type].

Note

Unavailable functions during color bar output are displayed in gray.

[Wiper]

Operate the wiper in order to remove the water droplets or dust adhered on the lens protector. By clicking [Execute], the wiper makes one to-and-fro movement and stops.

[Washer]

Operates a washer (sold on the market).

By clicking [Execute], after sending a signal for water discharge to the washer, the wiper operates. Sends stop signal to the washer during the wiper operation.

Note

Presets cannot be called while the washer is in operation.

[AUX OUT]

Outputs signal to external devices.

Set the operation mode of the output terminal in [System] > [System] > [Camera] > [AUX OUT].

[AUX IN]

Displays the status of the contact input signal from the external device.

■: Input active status

■: Input inactive status

[Add-On] (P. 83)

Click [View] to display a list of the running applications.

When you click [Open] for the application you want to use, [Add-On Top Page] is displayed, where you can configure the application settings.

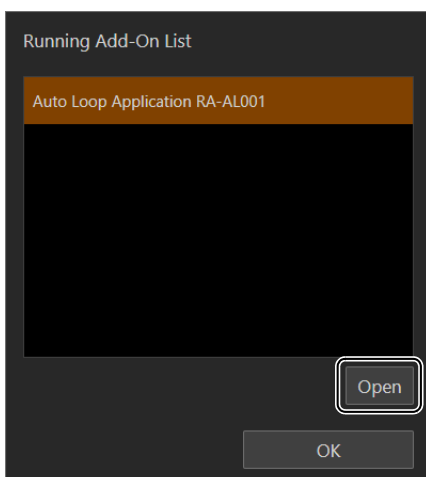

System Settings

Configure advanced camera system settings such as video and audio, server, communications, and security. If selecting the [System] menu in the settings area, the video display/operation area disappears and the following appears.

Screen Configuration

When [System] menu is clicked, the setting items category is displayed on the left side of the screen, and the setting screen is displayed on the right side.

Categories of the setting items can also be displayed by clicking the  at the upper right of the screen.

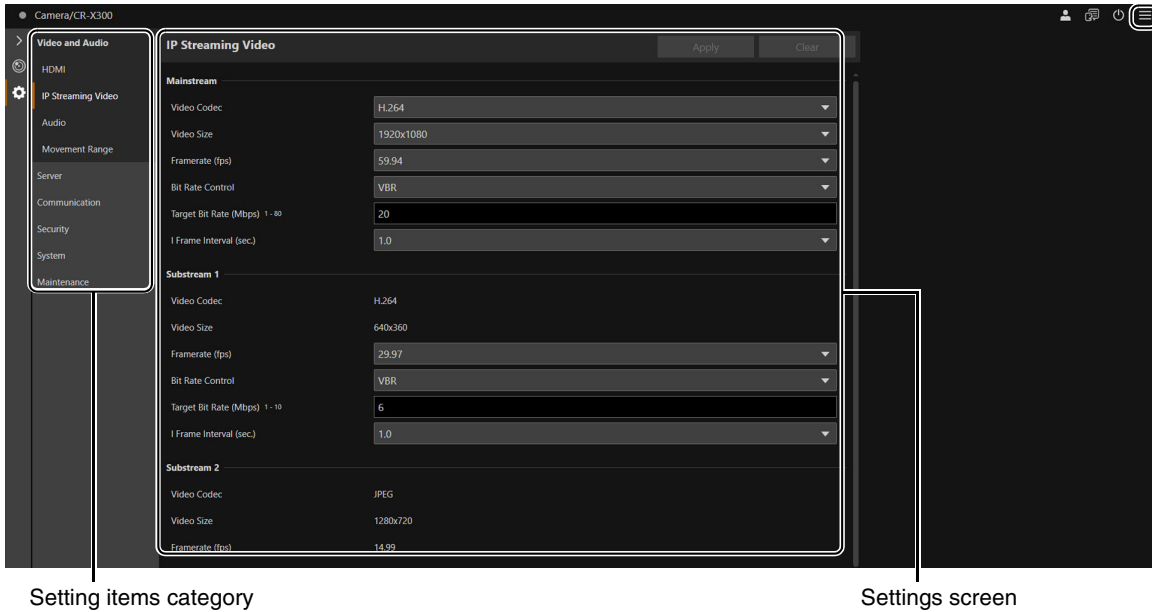

If the width of the screen is narrow, operations must be made from the  menu since the categories of the setting items are hidden.

Setting Items

Following is the overview of each item in the system settings.

Category	Item	Description
Video and audio	HDMI/SDI	Setting the common output signal method for HDMI/SDI and 3G-SDI mapping (P. 57).
	IP Streaming Video	General settings of the video, such as video size and quality sent from the camera (P. 58).
	Audio	Setting input audio from the built-in microphone and the bit rate in the IP audio distribution (P. 60).
	Movement Range	Pan/Tilt movement range settings (P. 61).
Server	HTTP/Video	Setting the HTTP Server and video server (P. 62).
	RTP	Communication setting using RTP Server (P. 63).
Communication	Network	Setting the network to which the camera is connected (P. 65).
	External Connection (IP)	Setting the communication protocol for IP connection of the camera with external devices such as controllers (P. 68).
	External Connection (Serial)	Setting the serial connection of the camera (P. 72).
Security	Certificate Management	Setting the certificate creation and management (P. 74).
	SSL/TLS	Encrypted communications and server certificate settings (P. 75).
	User Management	Adding/deleting administrator account information and authorized users, setting operating privileges (P. 76).
	Host Access Restrictions	Setting separate access controls for access from IPv4 and IPv6 addresses (P. 78).
System	Camera	Settings for camera operation; camera name, installation conditions and others (P. 80).
	Add-On (Add-On Applications System)	Management of applications installed on the camera (P. 83).
	Date and Time	Camera date and time settings (P. 85).
	Environment	Frame frequency settings (P. 87).
Maintenance	General	Device information and settings, license verification, reboot and initialization settings (P. 88).
	Backup/Restore	Perform backup and restoration (P. 90).
	Update Firmware	Perform firmware update (P. 91).
	Log	Log display and downloading message (P. 92).

Common Operations

Describes common operations in system settings.

Note

If a setting that does not display a dialog in a web browser is enabled, it may not be possible to operate the Settings Page. In this case, close and restart the web browser.

■ Applying Configuration Changes

When a setting is changed on the Settings Page, the [Apply] and [Clear] buttons in the upper right of the Settings Page are no longer grayed out and can be clicked.



In this situation, if [Apply] is clicked, the changed settings will be applied. Click [Clear] to revert to the previous settings.

■ Changes to Settings that Require to Reboot

Settings that require the camera to be restarted for the changed settings to take effect are preceded by a green [Reboot] symbol.



When an item that has a [Reboot] symbol is changed, [Apply] in the upper right of the Settings Page changes to [Apply and Reboot].

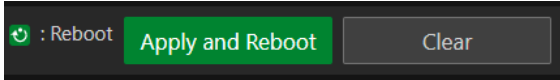

Click [Apply and Reboot] to apply the changes and restart the camera.
Click [Clear] to revert to the previous settings.



Important

If switched to another settings screen without clicking [Apply] or [Apply and Reboot], changes will be lost. Be sure to click [Apply] or [Apply and Reboot] to apply changes.

■ Setting Range and Character Limit

For setting items requiring numeric value input and character input, the allowable range and character limit are displayed.

Enter within the displayed ranges.

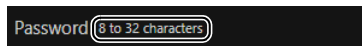

[System] > [Video and Audio] > [HDMI/SDI]

Settings for the video output configuration of the HDMI and SDI terminals.

HDMI/SDI [Apply] [Clear]

HDMI/SDI

Video Output Configuration: 1920x1080/59.94P

SDI

3G-SDI Mapping: Level A

Time Code Output: Enable

HDMI/SDI

Settings for the video output configuration to be commonly used for HDMI/SDI.

[Video Output Configuration]

The video output format is set as a combination of the video size and frame rate.

The selectable HDMI/SDI video output configuration varies depending on the [Frame Frequency (Hz)] set in [System] > [System] > [Environment].

Frame Frequency (Hz)	HDMI/SDI video output configuration (video size/frame rate)
23.98	1920x1080/23.98P, 3840x2160/23.98P
29.97	1920x1080/29.97P, 3840x2160/29.97P
59.94	1280x720/59.94P, 1920x1080/59.94P, 1920x1080/59.94i
25.00	1920x1080/25.00P, 3840x2160/25.00P
50.00	1280x720/50.00P, 1920x1080/50.00P, 1920x1080/50.00i

The settings and options for each video stream vary depending on the selected video output configuration. See [System] > [Video and Audio] > [IP Streaming Video] for more information.

[Output Terminal]

When the video size is 3840 x 2160, set the output terminal to HDMI or SDI.

SDI

Settings for the output signal method of the SDI terminal.

[3G-SDI Mapping]

When [Video Output Configuration] is [1920x1080/59.94P] or [1920x1080/50.00P], select the mapping method of the output signal of the SDI terminal. A signal conforming to Level A or Level B of the SMPTE ST 425-1 standard is outputted.

[Time Code Output]

Set to [Enable] to superimpose the timecode on the SDI terminal output.

[System] > [Video and Audio] > [IP Streaming Video]

Settings for the general video settings such as size and quality for the video to be distributed via IP. Settings are made for each of the following three streams.

- Mainstream
- Substream 1
- Substream 2

Stream	Video Codec	Video Size	Framerate (fps)	Bit Rate Control	Target Bit Rate (Mbps)	I Frame Interval (sec.)
Mainstream	H.264	1920x1080	59.94	VBR	20	1.0
Substream 1	H.264	640x360	29.97	VBR	6	1.0
Substream 2	JPEG	1280x720	14.99			

The options for [Video Size] and [Framerate (fps)] that can be selected for each video stream vary depending on the frame frequency set in [System] > [System] > [Environment].

Mainstream

Set the Mainstream video to be distributed from the camera.

[Video Codec]

Select the video codec type.

In the following cases, the video codec is fixed to H.264.

- If [System] > [Communication] > [External Connection (IP)] > [RTMP] is [Enable],

Note

If [I Frame Interval (sec.)] is set to [ALL-I], [H.265] cannot be set.

[Video Size]

Select a video size.

When the frame frequency is 59.94 Hz or 50.00 Hz, [3840 x 2160] cannot be set.

[Framerate (fps)]

Select the frame rate of the video.

[Bit Rate Control]

Settings for the video bit rate.

In order to control the bit rate strictly such as in an environment subject to the bandwidth limitations, set to [CBR].

[Target Bit Rate (Mbps)]

Enter the target value of the bit rate when [Bit Rate Control] is set to [CBR].

Enter a bit rate as an image quality reference when [Bit Rate Control] is set to [VBR]. Depending on the video, the set bit rate may be exceeded.

The maximum value that can be entered differs depending on the settings of [Video Size] and [Framerate (fps)].

[I Frame Interval (sec.)]

Select the interval (sec.) to insert an I frame into the video selected in [Video Codec]. Specify [ALL-I] if wanting all frames to be I-frames.



Note

When [Video Codec] is set to [H.265], [ALL-I] cannot be set.

Substream 1

Settings for the video of Substream 1 to be distributed from the camera.

[Video Codec]

Fixed to H.264.

[Video Size]

Fixed at 640 x 360.

[Framerate (fps)], [Bit Rate Control], [Target Bit Rate (Mbps)], [I Frame Interval (sec.)]

Refer to each item of [Mainstream].



Note

[Framerate (fps)] of Substream 1 cannot be set to [59.94] or [50.00].

Substream 2

Displays the set value for the video of Substream 2 to be distributed from the camera.

[Video Codec]

Fixed to JPEG.

[Video Size]

Fixed at 120 x 720.

[Framerate (fps)]

The set value is displayed according to the frame frequency.

[System] > [Video and Audio] > [Audio]

Bit rate settings for the audio input from the built-in microphone and for IP audio streaming.

The screenshot shows the 'Audio' configuration page. Under 'General Audio', 'Audio Input' is set to 'Enable', 'Input Volume' is 50, and 'Attenuator' is 'Disable'. Under 'IP Audio Streaming', 'Distribution Bit Rate (kbps)' is set to 128. The interface includes 'Apply' and 'Clear' buttons at the top right.

General audio

Settings for the volume of the audio input and the audio input operation with the built-in microphone.

[Audio Input]

Select whether to use audio from the built-in microphone.

When [Disable] is selected, audio will not be outputted from HDMI/SDI output.



Note

To set [Audio Input] to [Disable], all of the following settings must be changed to [Disable].

- [System] > [Server] > [RTP Server] > Each stream (Main, Sub1, Sub2) > [Audio Transmission]
- [System] > [Communication] > [External Connection (IP)] > [NDI|HX] > [Audio Transmission]
- [System] > [Communication] > [External Connection (IP)] > [RTMP] > [Audio Stream]
- [System] > [Communication] > [External Connection (IP)] > [SRT] > [Audio Stream]

[Input Volume]

Settings for the input volume from the built-in microphone.

[Current Volume Level (L)], [Current Volume Level (R)]

Displays the current volume level in the status bar.

[Attenuator]

Select whether to use the attenuator.

IP Audio Streaming

Features settings for IP Audio streaming.

[Distribution Bit Rate (kbps)]

Select the bit rate for distribution.



Important

- Video and audio may not sync.
- Depending on the performance of the computer and the network environment, audio may be interrupted.
- If using antivirus software, audio may be interrupted.
- If communication is temporarily interrupted by reseating of the LAN cable for example, the audio will be disconnected. In this case, reconnect the device to the camera.

[System] > [Video and Audio] > [Movement Range]

Settings for the pan/tilt movement range.

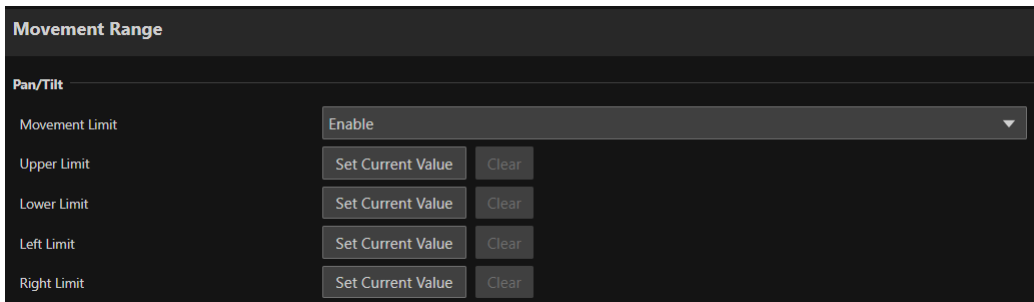

The screenshot shows a dark-themed interface titled "Movement Range". Under the "Pan/Tilt" section, there is a "Movement Limit" dropdown menu currently set to "Enable". Below this, there are four rows of controls for setting limits: "Upper Limit", "Lower Limit", "Left Limit", and "Right Limit". Each row contains two buttons: "Set Current Value" and "Clear".

Limit Type	Set Current Value	Clear
Movement Limit	Enable	
Upper Limit	Set Current Value	Clear
Lower Limit	Set Current Value	Clear
Left Limit	Set Current Value	Clear
Right Limit	Set Current Value	Clear

Pan/Tilt

It is possible to limit the pan/tilt movement range.

[Movement Limit]

When set to [Enable], pan/tilt movement range for all operations is limited, including preset/trace execution and Add-On application operations.

[Upper Limit], [Lower Limit], [Left Limit], [Right Limit]

When [Movement Limit] is set to [Enable], sets or clears the pan/tilt movement limit (top, bottom, left, and right edges).

Click [Set Current Value] for each edge to set the current pan/tilt position as the limit.

Click [Clear] to clear the movement limit.

[System] > [Server] > [HTTP/Video]

Settings for the HTTP Server for distributing Settings Page and videos over the network, and video distribution via HTTP.

HTTP/Video Reboot Apply Clear

HTTP Server

Authentication Method: Digest Authentication

HTTP Port: 80

HTTPS Port: 443

Video Server

Maximum Number of Clients: 15

Maximum Connection Time (sec.): 0

HTTP Server

Settings for the authentication method and HTTP port.

Important

Displays a confirmation dialog if the connection to the camera from the active web browser may become disabled by the changes of the [HTTP port] or [HTTPS port] settings. If the changed settings are to be applied, click [OK].

If unable to reconnect to the camera from the web browser after restarting the camera, a message appears with a suggested URI, if any, to reconnect to the camera.

If unable to connect to the camera through the displayed URI, contact your system administrator.

[Authentication Method]

Select the authentication method to be used by the HTTP Server.

[HTTP Port]

Enter the HTTP port.

In general, use [80] (factory default setting).

[HTTPS Port]

Enter the HTTPS port.

In general, use [443] (factory default setting).

Video Server

Settings for clients which can connect to the Video Server.

[Maximum Number of Clients]

Enter the maximum number of clients that can connect to the camera simultaneously.

If [0] is entered, only the administrator is allowed to connect.

Important

If there are many clients to distribute, the video frame rate may decrease or the audio may be cut off.

[Maximum Connection Time (sec.)]

Enter the maximum time, in seconds, that individual client can connect to the camera.

If [0], the connection time is unlimited.

[System] > [Server] > [RTP]

Settings for video and audio distribution using RTP.

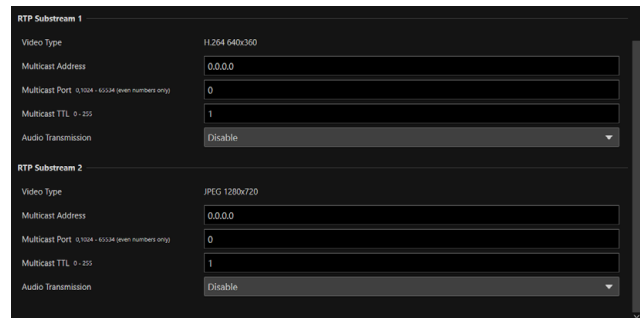
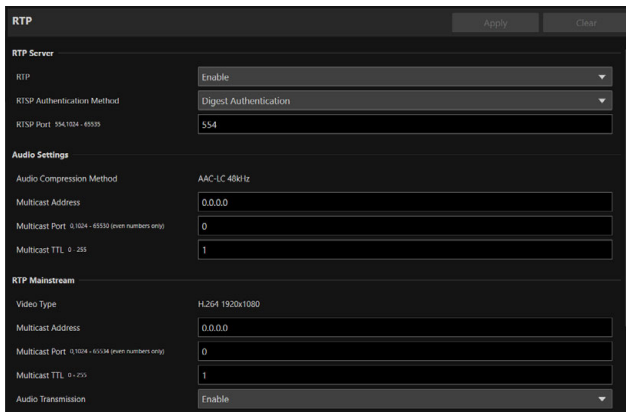

RTP Server

Settings for use of RTP, RTSP authentication method and port number.

[RTP]

Select whether to use RTP.

[RTSP Authentication Method]

Select a RTSP authentication method. Since RTSP authentication method is set independently from HTTP Server authentication method, it is necessary to configure the settings for each authentication method.

[RTSP Port]

Enter the RTSP port.

In general, use [554] (factory default setting).

Audio Settings

Settings for multicast audio transmission.

[Audio Compression Method]

Displays the audio compression method and the frequency. Fixed at AAC-LC 48kHz.

[Multicast Address]

Enter multicast address for audio transmission as follows.

IPv4: in the range of 224.0.0.0 to 239.255.255.255

IPv6: address starting with ff00::/8

[Multicast Port]

Enter multicast port for audio transmission.

[Multicast TTL]

Enter the effective range for multicast distribution.

The TTL (Time To Live), representing the effective range for multicast distribution, is decremented each time the signal passes through a router. When it reaches 0, distribution through a router becomes impossible.

For example, if TTL is set to [1], multicast distribution is confined to the local segment only and cannot pass through the router.



Note

With one of the following settings, audio multicast distribution is disabled.

- Set [0.0.0.0] (IPv4) or [::0(::)] (IPv6) for [Multicast Address].
- Set [0] for [Multicast Port] or [Multicast TTL].

RTP Mainstream, RTP Substream 1, RTP Substream 2

Settings for each stream for RTP stream distribution.

[Video Type]

Displays [Video Codec] and [Video Size] set for each video stream in [System] > [Video and Audio] > [IP Streaming Video].

[Multicast Address]

Enter multicast address for RTP stream as follows.

IPv4: in the range of 224.0.0.0 to 239.255.255.255

IPv6: address starting with ff00::/8

[Multicast Port]

Enter multicast port for RTP stream.

[Multicast TTL]

Enter the effective range for multicast distribution of RTP stream.

The TTL (Time To Live), representing the effective range for multicast distribution, is decremented each time the signal passes through a router. When it reaches 0, distribution through a router becomes impossible.

For example, if TTL is set to [1], multicast distribution is confined to the local segment only and cannot pass through the router.

[Audio Transmission]

Select whether to use the audio transmission of RTP stream.

When [Disable] is set for [System] > [Video and Audio] > [Audio] > [General Audio] > [Audio Input], [Enable] cannot be set.



Note

- With one of the following settings, the multicast distribution of RTP stream is disabled.
 - Set [0.0.0.0] (IPv4) or [::0(::)] (IPv6) for [Multicast Address].
 - Set [0] for [Multicast Port] or [Multicast TTL].
- URL for RTP stream
rtsp://IP address: port/rtpstream/config1(to 3)
Example: rtsp://192.168.100.1:554/rtpstream/config1
 - Distribution method depends on the request for distribution from the RTP client application.
 - config1 requests the distribution of RTP Mainstream, config 2 requests RTP Substream 1, and config 3 requests RTP Substream 2.
- Video quality of Main and Sub1 with [Bit Rate Control], etc. uses the settings in [System] > [Video and Audio] > [IP Streaming Video] (P. 58) .
- [Video Distribution] in [System]> [Security]> [User Management]> [User Authority] is not reflected in RTP.
- In an environment using proxy server or firewall, the video from the RTP stream may not be displayed. In such a case, contact your system administrator.
- When the host access restriction is applied to a client during the RTP over UDP stream distribution, it may take from a few seconds to several tens of seconds to stop the distribution.

[System] > [Communication] > [Network]

Settings for connecting to the network.

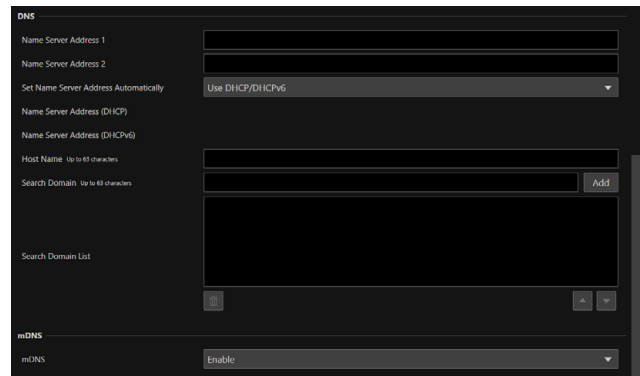
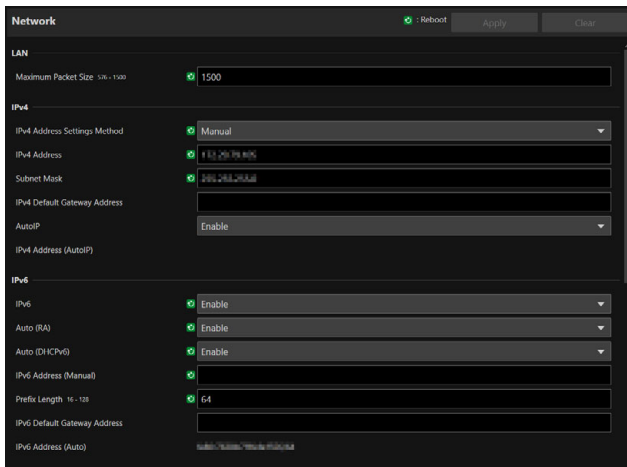

Important

If changing settings related to network connection, it might not be possible to connect to the camera from the web browser. In this case, by clicking [Apply] or [Apply and Reboot], a dialog for confirmation will be displayed. Click [OK] to apply the change. If unable to reconnect to the camera from the web browser after the camera is restarted due to a configuration change, a message appears with a suggested URI, if any to reconnect to the camera. If unable to connect to the camera through the displayed URI, contact your system administrator.

LAN

Settings for the transmission data size from the camera.

[Maximum Packet Size]

Enter the maximum size for the packets transmitted from the camera. In general, it is not necessary to change from 1500. When using IPv6, it is necessary to set 1280 or higher. When using ADSL, by slightly decreasing the value, transmission efficiency may be improved.

IPv4

Settings for connection to the camera over IPv4. IPv4 address can be acquired automatically from the DHCP Server or can be set manually.

Important

- Regarding [IPv4 Address], [Subnet Mask] and [IPv4 Default Gateway Address] for manual setting of IPv4, contact your system administrator.
- If there is any error in the settings of [IPv4 Address], [Subnet Mask] or [IPv4 Default Gateway Address], access via network may not be possible. In such a case, search cameras using the Camera Search Tool, and set the address again.

[IPv4 Address Settings Method]

Select the IPv4 address settings method.

For [Manual], enter a fixed IPv4 address to [IPv4 Address].

For [Auto (DHCP)], a value acquired from DHCP Server will be set automatically to [IPv4 Address (DHCP)] and [IPv4 Default Gateway Address (DHCP)].



Important

When using IPv4 address settings in [Auto (DHCP)], in an environment with a router between the DHCP Server and the camera, IPv4 address may not be assigned correctly. In such a case, select [Manual] to set the fixed IPv4 address.

[IPv4 Address]

When [IPv4 Address Settings Method] is [Manual], enter the fixed IPv4 address.

[Subnet Mask]

When [IPv4 Address Settings Method] is [Manual], enter the subnet mask value specified for each network.

[IPv4 Default Gateway Address]

When [IPv4 Address Settings Method] is [Manual], enter a value. Make sure to set, when connecting the camera to a subnet different from IP connection device such as controller.

[AutoIP]

Select whether to use AutoIP. When the AutoIP address is enabled, IP address automatically set will be displayed in [IPv4 Address (AutoIP)].

IPv6

Settings for connection to the camera over IPv6. IPv6 address can be acquired automatically from the RA or the DHCPv6 Server, or can be set manually.



Important

Regarding [IPv6 Address (Manual)], [Prefix Length] and [IPv6 Default Gateway Address] for manual setting of IPv6, contact your system administrator.

[IPv6]

Select whether to use IPv6.

[Auto (RA)]

Select [Enable], when automatically setting the address using RA (Router Advertisement, network information transmitted automatically from the router).

[Auto (DHCPv6)]

Select [Enable], when automatically setting the address using DHCPv6.

[IPv6 Address (Manual)]

For setting the address manually, enter a fixed IPv6 address.

[Prefix Length]

For setting the address manually, enter a prefix length.

[IPv6 Default Gateway Address]

For setting the address manually, enter a default gateway address. Make sure to set, when connecting the camera to a subnet different from IP connection device such as controller.

[IPv6 Address (Auto)]

When [IPv6] is [Enable] and [Auto (RA)] or [Auto (DHCPv6)] is [Enable], the address automatically acquired will be displayed.

DNS

Settings for the DNS Server address. DNS Server address can be set manually or can be acquired automatically from the DHCP/DHCPv6 Server.

[Name Server Address 1], [Name Server Address 2]

Enter the name server address to be registered. When only one address is to be registered, leave [Name Server Address 2] blank.

Note

If [Name Server Address 1] cannot be used, make access to [Name Server Address 2]. However, it is assumed that [Name Server Address 2] is set beforehand.

[Set Name Server Address Automatically]

Select the server for setting automatically the name server address.

When using DHCP, set [IPv4 Address Settings Method] to [Auto (DHCP)] (P. 65).

When using DHCPv6, set [IPv6] to [Enable] and [Auto (DHCPv6)] to [Enable] (P. 66).

[Name Server Address (DHCP)]

When [Set Name Server Address Automatically] is set as [Use DHCP] or [Use DHCP/DHCPv6], the name server address acquired from the DHCP Server will be displayed.

[Name Server Address (DHCPv6)]

When [Set Name Server Address Automatically] is set as [Use DHCPv6] or [Use DHCP/DHCPv6], the name server address acquired from the DHCPv6 Server will be displayed.

[Host Name]

The host name of the camera can be registered with alphanumeric characters to the name server.

[Search Domain]

When adding a domain name to the search domain list, enter the domain name and click [Add].

If a domain name is specified in the search domain list, it will be handled in the form of host name + domain name simply by specifying the host name without the domain name in the specified server such as NTP and RTMP.

[Search Domain List]

Displays a list of domain names added in [Search Domain].

Queries are sent to the DNS Server in order from the top of the list of domain names.

With the ▲ or ▼ button on the right, the order of the domain names can be changed.

Select a domain name and click  to delete the domain name.

mDNS

Settings for use of multicast DNS. When using mDNS, IP address and host name information of the camera is notified to other hosts on the network.

[mDNS]

Select whether to use mDNS.

For using NDI|HX as a communication protocol (P. 68), set [mDNS] to [Enable].

[System] > [Communication] > [External Connection (IP)]

Settings for communication for connecting controllers, etc. via IP.

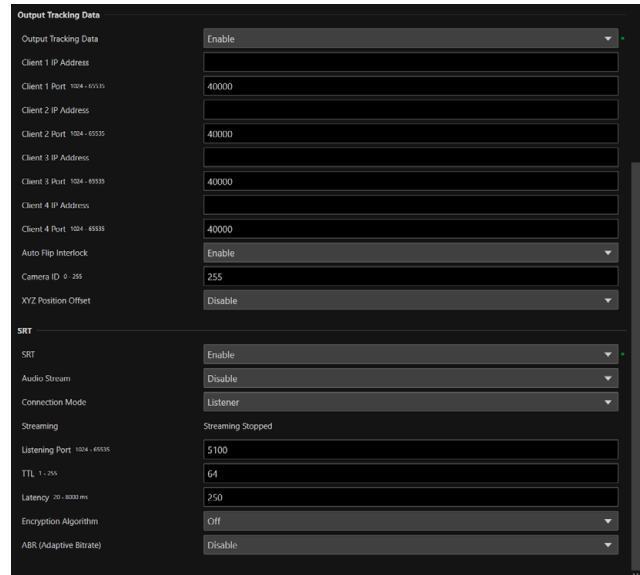
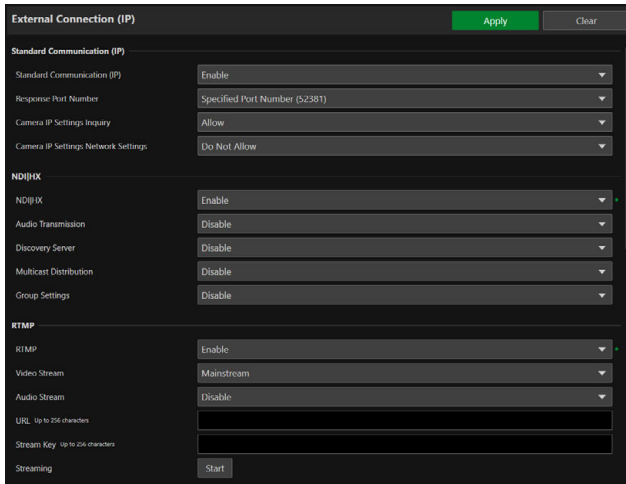

Standard Communication (IP)

Settings for operating the cameras from the controller connected by the standard IP communication.

[Standard Communication (IP)]

Select whether to use [Standard Communication (IP)] for the connection with the controller.

[Response Port Number]

Select whether to use a fixed port number (52381) or a source port number when communicating with the controller.

[Camera IP Settings Inquiry]

Select whether to allow the inquiry on the camera IP settings from the controller.

[Camera IP Settings Network Settings]

Select whether to allow to change the network settings of the camera from the controller.

NDI|HX

Settings for exchanging data with NDI|HX supported devices.

[NDI|HX]

Select whether to use [NDI|HX] as the communication protocol.

For setting to [Enable], go to [System] > [Communication] > [Network] > [mDNS] and select [Enable] (P. 67).

[Audio Transmission]

Select whether to use the audio transmission.

When [Disable] is set for [System] > [Video and Audio] > [Audio] > [General Audio] > [Audio Input], [Enable] cannot be set.

[Discovery Server]

Select whether to use the Discovery Server.

When set to [Enable], it only notifies the Discovery Server of the IP address and does not notify other hosts of the IP address nor hostname.

[Discovery Server IP Address]

Enter the IP address of the Discovery Server.

[Multicast Distribution]

Select whether to use the multicast distribution.

Note

For multicast distribution, set the multicast distribution enabled in the NDI client side as well.

[Multicast TTL]

Enter the effective range for multicast distribution.

The TTL (Time To Live), representing the effective range for multicast distribution, is decremented each time the signal passes through a router. When it reaches 0, distribution through a router becomes impossible.

For example, if TTL is set to [1], multicast distribution is confined to the local segment only and cannot pass through the router.

[Group Settings]

Select whether to use the group settings.

When a group name to which the camera belongs is specified, the camera connects only to NDI clients with the same group name.

[Group Name], [Group List]

Enter the group name.

By clicking [Add], the entered group name will be displayed in the group list.

Able to sort the list items in ascending order by clicking  and in descending order by clicking .

Select a group in the group list and click  to delete the group.

RTMP

A communication protocol for the streaming playback of video and audio, and sending and receiving the data.

[RTMP]

Select whether to use [RTMP] as the communication protocol.

Note

When [System] > [Video and Audio] > [IP Streaming Video] > [Mainstream] > [Video Codec] is set to [H.265], RTMP cannot be used.

[Video Stream]

Select the type of the video stream. Substream 2 cannot be used.

[Audio Stream]

Select whether to use the audio stream.

When [Disable] is set for [System] > [Video and Audio] > [Audio] > [General Audio] > [Audio Input], [Enable] cannot be set.

[URL]

Enter the URL of the server set on the distribution server side.

Enter the string of characters starting with rtmp:// or rtmps://.

[Stream Key]

Enter the stream key set on the distribution server side.

[Streaming]

By clicking [Start] to start the streaming, the button becomes [Stop].

By clicking [Stop], the streaming ends.

Output Tracking Data

Configures the output of camera tracking data (pan, tilt, zoom, etc.) required when using the virtual studio system in a format compliant with the free-d protocol. The supported message type is Type D1.

[Output Tracking Data]

Select whether to use the camera's Output Tracking Data.

[Client (1 to 4) IP Address]

Enter the IP address of the client that will receive the camera tracking data.

[Client (1 to 4) Port]

Enter the number corresponding to each [Client (1 to 4) IP Address].

[Auto Flip Interlock]

Select whether or not the roll angle is changed when the video is flipped using [Auto Flip] (P. 81).
The angle is set to 180° if [Enable] is selected, and set to 0° if [Disable] is selected (both settings are fixed).

[Camera ID]

Enter the ID that identifies the camera. Be sure to use single-byte numeric characters.

[XYZ Position Offset]

Select whether to specify the camera position.

[X], [Y], [Z]

Enter the value for each.

Note

- The data to be stored and output are as follows. When a still image is displayed during preset movement, values other than Camera ID and Checksum are not changed.
Camera ID: Stores the ID set in [Camera ID].
Camera Pan Angle / Camera Tilt Angle / Camera Roll Angle: Stores the camera angles in the format specified by the free-d protocol.
 - Pan: -180° to 180°
 - Tilt: -40° to 215°
 - Roll: Angle (fixed): 0° or 180°Camera X-Position / Camera Y-Position / Camera Height (Z-Position) : Stores the value set in [XYZ Position Offset].
Camera Zoom: Stores Zoom type and zoom position.
Camera Focus: Stores the Focus value.
Spare/Undefined Data: Stores the iris value.
Checksum: Stores the Checksum value calculated by the method specified in the free-d protocol.
- If [Genlock] is [Enable], packets are sent along with the genlock signal.
- If lag occurs in the camera tracking data's transmission interval, it may be stabilized by closing the Settings Page or stopping IP streaming.
- If you output tracking data to multiple clients, the data is sent in order starting with the lowest client number.
To avoid a delay between transmissions, use a lower client number. The amount of delay depends on the system and network conditions.

SRT

Configures settings for exchanging data with SRT (Secure Reliable Transport) compliant devices.

[SRT]

Select whether to use [SRT] as the communication protocol.

[Audio Stream]

Select whether to use the audio stream.

When [Disable] is set for [System] > [Video and Audio] > [Audio] > [General Audio] > [Audio Input], [Enable] cannot be set.

[Connection Mode]

Sets the connection mode of the camera. Select [Caller] if you want the camera to connect to an external device, or select [Listener] if you want the camera to listen for connections from an external device.

[Streaming]

If the [Connection Mode] is [Caller], clicking [Start] will start the streaming and the button will be [Stop]. By clicking [Stop], the streaming ends.

[Destination], [Destination Port]

Enter the IP address/host name/port number of the connection destination when [Connection Mode] is [Caller].

[Listening Port]

Enter the port number of the connected device when [Connection Mode] is [Listener].

[TTL]

Enter the TTL (Time To Live) of the packet.

The TTL, which represents the valid range of the packet, is decremented by 1 each time it crosses a router, and when it reaches 0, it cannot be delivered beyond the router. For example, setting the TTL to [1] results in delivery only to a local segment.

[Latency]

Sets the delay time for SRT delivery. Delay time is the time it takes for a lost packet to be recovered. The unit is "ms" (milliseconds).

[Stream ID]

Sets an ID to identify the stream when [Connection Mode] is [Caller]. Enter in single-byte alphanumeric characters, numbers, or symbols.

[Encryption Algorithm]

Select the encryption algorithm (AES-128 / AES-192 / AES-256 / Off).

**Important**

When using encryption, the [Mainstream] > [Target Bit Rate (Mbps)] setting will be restricted.

[Passphrase]

Sets the passphrase to be used for encryption. Enter in single-byte alphanumeric characters, numbers, or symbols. The same passphrase as the connected device must be set.

[ABR (Adaptative Bitrate)]

Dynamically changes the bit rate within the target bit rate range (P. 58), depending on the network bandwidth. Reduces video pauses and distortion caused by network congestion.

[System] > [Communication] > [External Connection (Serial)]

Settings for communication by the serial connection of controllers, etc.

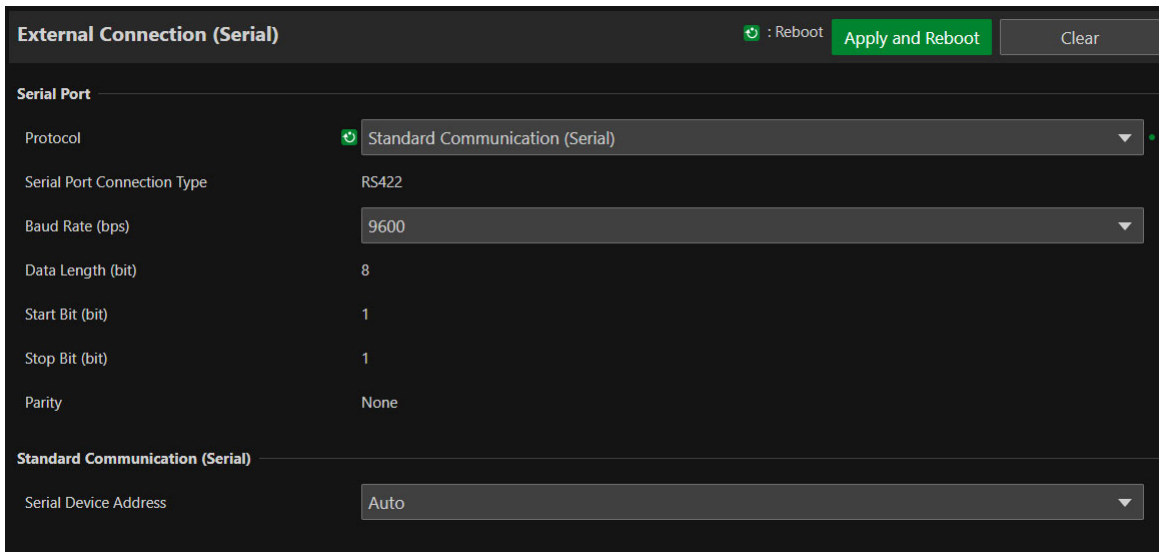

External Connection (Serial) Reboot Apply and Reboot Clear

Serial Port

Protocol Standard Communication (Serial)

Serial Port Connection Type RS422

Baud Rate (bps) 9600

Data Length (bit) 8

Start Bit (bit) 1

Stop Bit (bit) 1

Parity None

Standard Communication (Serial)

Serial Device Address Auto

Serial Port

Detail settings for the serial port.

[Protocol]

Select either the [NU] protocol or [Standard Communication (Serial)] protocol to be used with the serial port. Set to [None], if the serial port is not used.

Note

To connect the Remote Camera Controller RC-IP100/RC-IP1000 by serial connection, set to [NU].

[Serial Port Connection Type]

Fixed to RS-422.

[Baud Rate (bps)]

Select the Baud Rate value.

Note

When the [Protocol] is set to [NU], [Baud Rate (bps)] will not be displayed.

[Data Length (bit)]

Data length of serial communication is fixed at 8 bit.

[Start Bit (bit)]

The length of the start bit is fixed at 1 bit.

[Stop Bit (bit)]

The length of the stop bit is fixed at 1 bit.

[Parity]

The settings for the error detection code is fixed to None.

Standard Communication (Serial)

Settings for connection with standard serial communication.

[Serial Device Address]

Select the address of the camera.

When [Auto] is selected, addresses will be automatically assigned.

[System] > [Security] > [Certificate Management]

Managing the server certificates. It is also possible to create a self-signed certificate to use, for example, for operation test.

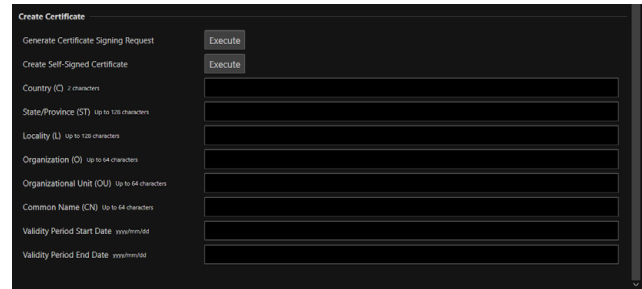
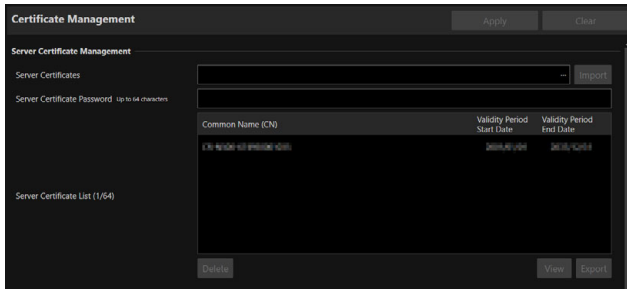

Server Certificate Management

Managing the server certificates.

[Server Certificates]

Imports server certificates.

Click [...] and specify the certificate file to be imported, and then click [Import].

[Server Certificate Password]

Set the password to use when importing and exporting the server certificate.

[Server Certificate List]

Click [View] to display the information of server certificates as a list. Certificate's validity is displayed in GMT (Greenwich Mean Time).

Select the certificate and click [Export] to export the certificate information. Click [Delete] to delete it from the list.

Create Certificate

Creates server certificates.

Important

It is advised to use self-signed certificates for cases such as operation tests that do not require full security. It is recommended to acquire and install a server certificate issued from CA for a full-scale system operation.

[Generate Certificate Signing Request]

Click [Execute] to create a server private key and generate a certificate signing request.

Once processed, the certificate signing request will be displayed in a separate window.

[Create Self-Signed Certificate]

Enter the following items, click [Apply], and click [Execute] to create a self-signed certificate.

Note

Creating a certificate takes time, so it is recommended to stop the video distribution processes etc.

[Country (C)]

Enter the ISO3166-1 alpha-2 country code.

[State/Province (ST)], [Locality (L)], [Organization (O)], [Organizational Unit (OU)], [Common Name (CN)]

Enter state/province name, locality name, organization name, organizational unit name and common name in alphanumeric characters (spaces or printable characters).

Enter an FQDN format host name, etc. to set the common name (required).

[Validity Period Start Date], [Validity Period End Date]

Set the validity period of the certificate to be created (required when creating a self-signed certificate).

[System] > [Security] > [SSL/TLS]

Settings for encrypted communications and server certificates.

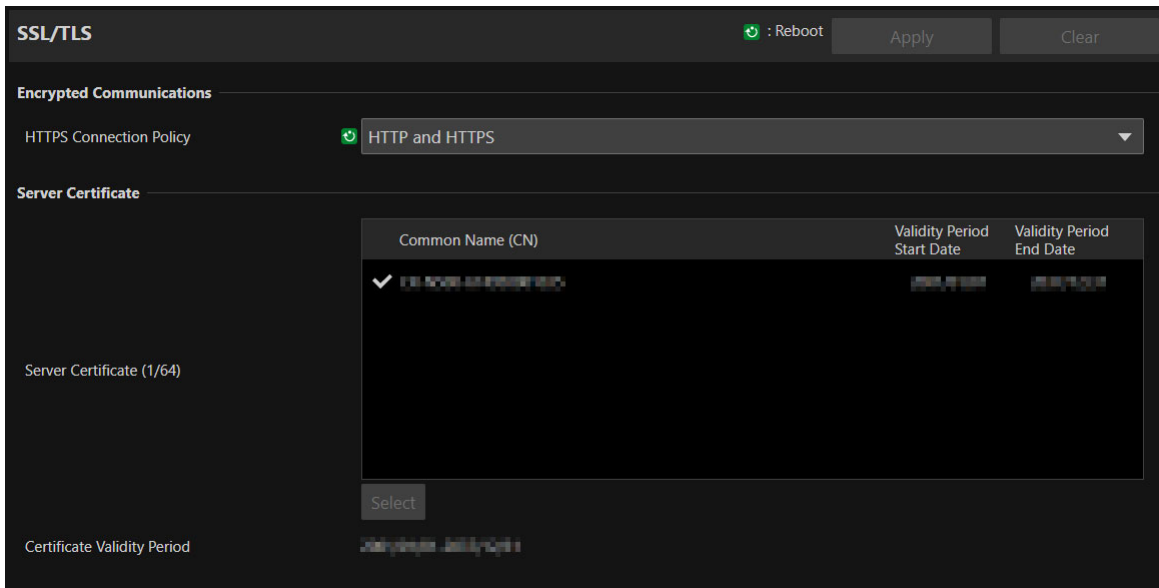

Encrypted Communications

Settings for encrypted communications.

[HTTPS Connection Policy]

Set SSL/TLS communication with HTTPS connections.

Select [HTTP] if SSL/TLS communication is not performed.

Select [HTTPS] or [HTTP and HTTPS] to perform SSL/TLS communication. Connections using SSL/TLS are enabled after rebooting.

If [HTTPS] is selected, HTTP access is also redirected to HTTPS to perform SSL/TLS communication.

Important

- Even if SSL/TLS communication is set to be used here, SSL/TLS communication is not performed unless a certificate has been installed.
- Video distribution performance decreases when performing SSL/TLS communication.

Server Certificates

Settings for server certificate for use.

[Server Certificate]

Select a certificate to use from the certificates registered in [System] > [Security] > [Certificate Management] > [Server Certificate Management], and click [Select]. The selected certificate takes effect after a reboot.

[Certificate Validity Period]

Displays the validity period of the selected certificate.

Note

Depending on the server certificate used by the camera and the computer connected to the camera, it may be necessary to install the root certificate, the intermediate CA certificate, or the certificate selected and exported in [Server Certificate List].

[System] > [Security] > [User Management]

Settings for account to access the camera via an IP connection from a controller, etc.

User Management Reboot Apply Clear

Administrator Account

Administrator Name 5 to 15 characters

Password 8 to 32 characters

Confirm Password 8 to 32 characters

Authorized User Account

User Name 5 to 15 characters

Password 8 to 32 characters

Confirm Password 8 to 32 characters Add

User List

User Authority

	Camera Control	Video Distribution
Authorized User	<input checked="" type="checkbox"/>	<input checked="" type="checkbox"/>
Guest User	<input checked="" type="checkbox"/>	<input checked="" type="checkbox"/>

"Administrator", "authorized user", and "guest user" are the three types of accounts that are able to access the camera. For the minimum user settings and granting privileges, refer to "Measures Suitable to the Users' Environment 1: User Management" (P. 118).

Administrator:

The administrator can access the Settings Page for all settings including granting privileges to authorized users and guest users. Access the camera with the administrator name and password registered with administrator account.

Authorized User:

This account is used to access the camera by authenticating with a user name and password. It is required to enter a user name and password of the controller or other connecting devices.

Guest User:

The account is used for the device to access the camera without user authentication.

Important

- Multiple administrator accounts cannot connect to a camera at the same time.
- Authorized user and guest user accounts can connect to the camera from multiple devices at the same time.
- When using NDI|HX, RTMP or SRT, access cannot be controlled by [User Management].

Administrator Account

Settings for changing the administrator account information that was set at initial setting.

Important

- To ensure system security, set the administrator password that should not be easily guessed by third parties. Be sure not to forget the password.
- If administrator password is forgotten, restore the factory default settings (P. 106). Note, however, that this will reset all camera settings to factory default settings including the administrator account, the network information, date and time.

[Administrator Name]

Enter the administrator name using only alphanumeric characters, hyphens (-), and underscores (_). However, hyphens (-), and underscores (_) cannot be used at the beginning.

[Password]

Enter the administrator password. Use at least two types of alphanumeric characters, numbers, or symbols.

[Confirm Password]

Enter the same password as above for confirmation.

Authorized User Account

Add authorized users.

[User Name], [Password], [Confirm Password]

To add an authorized user, enter the user name and password, then click [Add].

Enter the user name using only alphanumeric characters, hyphens (-), and underscores (_).

Up to 15 authorized users can be added.

For password, use at least two types of alphanumeric characters, numbers, or symbols.

[User List]

Displays a list of added authorized users.

Able to sort the list items in ascending order by clicking  and in descending order by clicking .

Select a user in the list and click  to remove the registered user.

User Authority

Set the privileges for authorized users and guest users. This setting enables to set access restrictions for the Settings Page.

[Camera Control], [Video Distribution]

Confirm the privilege items to be granted to each user.

An authorized user has higher privileges than a guest user.

If [Video Distribution] is not selected, the Settings Page is not displayed. To display the Settings Page, enter the user name and password of an account with video distribution privilege in the dialog displayed when the Settings Page is opened or when switching accounts.

Important

However, when connected to the RTP server as an authorized user, it is not possible to set restrictions by the user's privilege.

[System] > [Security] > [Host Access Restrictions]

Access control can be performed individually by address to access over the network. Set for IPv4 and IPv6, respectively.

The screenshot shows the 'IPv4 Host Access Restrictions' configuration page. It includes a title bar with 'Apply' and 'Clear' buttons. Below the title, there are two dropdown menus: 'Apply Host Access Restrictions' set to 'Enable' and 'Default Policy' set to 'Authorize Access'. A table with 18 rows is visible, each with a port number (01-18) in the first column, a slash and a number (32) in the second column, and a 'Yes' dropdown in the third column. At the bottom, there is a label 'Network Address/Subnet'.

The screenshot shows the 'IPv6 Host Access Restrictions' configuration page. It includes a title bar with 'Apply' and 'Clear' buttons. Below the title, there are two dropdown menus: 'Apply Host Access Restrictions' set to 'Enable' and 'Default Policy' set to 'Authorize Access'. A table with 17 rows is visible, each with a port number (01-17) in the first column, a slash and a number (128) in the second column, and a 'Yes' dropdown in the third column. At the bottom, there is a label 'Prefix/Prefix Length'.

Important

- To prohibit access via a proxy server in HTTP connection, a proxy server address must be set.
- Note that incorrect host restriction settings may prohibit access to the Settings Page itself, and there may be no way to recover other than to revert to factory default settings.

Note

If the same address is set, the setting placed higher in the list will be applied.

IPv4 Host Access Restrictions

Specify the hosts from which IPv4 access is authorized and prohibited.

[Apply Host Access Restrictions]

Select whether to use IPv4 host access restrictions.

[Default Policy]

Select whether to authorize or prohibit access from IPv4 addresses that have not been specified in [Network Address/Subnet].

[Network Address/Subnet]

Enter IPv4 addresses in the list and select [Yes] or [No] for access for each address.

It is possible to specify the subnet to set access restrictions by network or host.

If set to [No], access to all ports is prohibited.

IPv6 Host Access Restrictions

Specify the hosts from which IPv6 access is permitted and prohibited.

[Apply Host Access Restrictions]

Select whether to use IPv6 host access restrictions.

[Default Policy]

Select whether to authorize or prohibit access from IPv6 addresses that have not been specified in [Prefix/Prefix Length].

[Prefix/Prefix Length]

Enter IPv6 addresses (prefixes) in the list and select [Yes] or [No] for access for each address.

It is possible to specify the prefix length to set access restriction by network or host.

If set to [No], access to all ports is prohibited.

[System] > [System] > [Camera]

Camera system settings.

Camera Reboot Apply Clear

Camera Name

Camera Name Up to 15 characters

Installation Conditions

Video Flip

Camera Control

Auto Flip

Freeze Image During Preset Movement (Default Value)

Zoom Speed Steps

Focus Speed Steps

Color Bars

Color Bar Type

AUX OUT

Operation Mode

Tally Lamp

Tally Lamp Control

Tally Lamp Brightness

Genlock

Genlock

Genlock Adjustment -1023 1023 0

Camera Name

Settings for the camera name.

[Camera Name]

Enter an arbitrary camera name.

Installation Conditions

Settings for camera use suitable for the location where the camera will be installed.

[Video Flip]

Select whether to vertically flip the video.

Configure the settings according to the camera installation method, such as ceiling mount or placing on a desk.

Camera Control

Settings related to camera control.

[Auto Flip]

Select whether to use the auto flip function.

In a tilt operation (P. 34), by using the auto flip function, the video display is inverted when the tilted angle approaches 90°. If the tilt operation is stopped after inverting the video, the tilt operation will be reversed by a ▲▼ button operation. It will be the same when operated by an external device such as a controller.

Note

Even if the video is inverted, the position of the tilt slider will not be inverted, which makes the video and the slider move in the opposite direction.

[Freeze Image During Preset Movement (Default Value)]

Sets whether to display a still image by default during preset movement.

[Zoom Speed Steps]

Select the number of zoom control speed steps when operating the zoom function using an external device, such as a controller.

[Focus Speed Steps]

Select the number of focus control speed steps when operating the manual focus function using an external device, such as a controller or via the Settings Page.

Color Bars

Sets the types of color bars.

When outputting the color bars, set [Other Functions] > [Color bars] to [On].

[Color Bar Type]

Select either SMPTE compliant, EBU compliant, or ARIB compliant.

AUX OUT

Settings for output operation to external devices.

When outputting to an external device, set [Other Functions] > [AUX OUT] to [On].



[Operation Mode]

Select whether the contact of the output terminal is normally open or close.

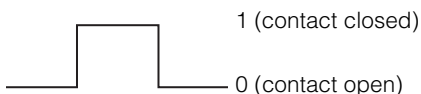

If set to [Normally Open], when the contact of the output terminal is closed, an active event occurs, and inactive event occurs when it is opened.

If set to [Normally Close], when the contact of the output terminal is opened, an active event occurs, and inactive event occurs when it is closed.

Normally Open

Active event status  1 (contact closed)
Inactive event status  0 (contact open)

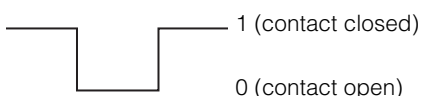
Normally Close

Inactive event status  1 (contact closed)
Active event status  0 (contact open)

Tally Lamp

Settings for the tally lamp.

[Tally Lamp Control]

Select whether to use tally lamp control.

[Tally Lamp Brightness]

Select the brightness of the tally lamp when [Tally Lamp Control] is set to [Enable].

Genlock

Genlock enables to synchronize the video signals between the camera and the external video device.

Use the GEN-LOCK terminal to input external sync signals (analog black burst signal or HD ternary signal) to the camera.

[Genlock]

Select whether to use Genlock.

[Genlock Adjustment]

Adjusts the H phase of the genlock in the range of approximately ± 0.4 H around the phase difference 0.



Note

- When a synchronizable Genlock signal is inputted, synchronization will stabilize after approximately 10 seconds.
- If an incorrect Genlock signal is inputted, synchronization may not be stable.

[System] > [System] > [Add-On]

Perform management such as adding and updating applications and licenses.

The screenshot displays the 'Add-On Management' interface. At the top, there is an 'Add/Update' section with a search bar and an 'Install' button. Below this is the 'Add-On List' section, which contains a table with the following data:

Name	Running
Auto Loop Application RA-AL001	Running

A 'Delete' button is located below the table. To the right of the table, a bracket labeled 'Application list' spans the 'Add-On List' and 'Delete' button areas. Below the table, the 'Free Space' is shown as 20184 KB (19.7 MB) and the 'Locking Code' is displayed as a series of asterisks. A bracket labeled 'Information about the selected application' spans the bottom half of the interface, which includes the following details for the selected application 'Auto Loop Application RA-AL001':

- Vendor: Canon Inc.
- Start Up/Stop: Running (with a 'Stop' button)
- Version: 1.1.0
- License: (with an 'Import' button)
- Enable: Trial License - 2023/11/03 (with a 'Delete' button)
- Add-On Top Page: (with an 'Open' button)
- Automatic Startup: (with a toggle switch set to 'On')
- Log: (with 'View' and 'Download' buttons)
- Back Up Settings: (with an 'Execute' button)
- Restore Settings: (with an 'Execute' button)
- Encryption Password: 0,0 to 32 characters
- Restore Default Settings: (with an 'Execute' button)

A callout box labeled '(1)' points to the application name 'Auto Loop Application RA-AL001' in the application list.

Add-On Management

Displays a list of the installed applications. In addition, you can also add and delete applications.

[Add/Update]

Click [...], specify the application to add/update, and click [Install].

[Add-On List]

Displays a list of applications and their status.

[Delete]

Select the application you want to delete, then click [Delete].
When a confirmation message is displayed, click [OK].

[Free Space]

Displays the free Add-On space. This allows you to estimate the space for applications that can be installed.

[Locking Code]

Displays the camera locking code (camera unique information). This is used when registering a license.

Information About the Selected Application

Information about the selected application* is displayed and you can perform tasks such as updating a license.

* The name of the currently selected application is displayed in (1).

[Vendor]

Displays the name of the application vendor.

[Start Up/Stop]

Displays the status of the application. The application can be controlled by clicking [Start Up] or [Stop]. You can run up to four applications at the same time.

[Version]

Displays the version of the application.

[License]

- Import: Click [...], specify a license file, and click [Import].
- Status: If [Disable] or [Not Registered] is displayed, check the license term or registration status again.
- Term: Displays the license term.
- Delete: Click [Delete] to delete the license file.

[Add-On Top Page]

When [Open] is clicked, [Add-On Top Page] is displayed, where you can configure the application settings. It can also be displayed by clicking [Camera Control] > [Other Functions] > [Add-On] (P. 53).

[Automatic Startup]

Select whether to automatically start up the application when the camera starts up. Up to four applications can be set.

[Log]

When [View] is clicked, the log messages for the application are displayed. When [Download] is clicked, the message list can be downloaded as a file.

[Back Up Settings]

Back up the settings of the selected application.

[Restore Settings]

Restore settings from the backup file created with [Back Up Settings].

Depending on the application, there may be functions that operate by referring to the camera settings. In that case, the camera's setting values must also be restored (P. 90).

[Encryption Password]

You can set a password to use when backing up and restoring settings. The password is used to encrypt the backup data itself. Use at least two character types from single-byte alphabetic characters, numbers, and symbols.

When restoring from encrypted backup data, enter the password set during the backup.

[Restore Default Settings]

Initializes the setting values of the selected application.



Note

- Even if a firmware update is performed for the camera and applications, the license is inherited.
- If [License status has changed. Please restart the Add-On.] is displayed, click [Stop] to stop the application, and then click [Start Up] to restart it.

[System] > [System] > [Date and Time]

Settings for date and time of the camera.

Date and Time Apply Clear

Current Date and Time

Date: yyyy/mm/dd

Time: hh:mm:ss

Settings

Settings Method: Synchronize with NTP server

Set NTP Server Settings Automatically: Disable

NTP Server: XXXXX

Synchronization Interval (minutes): 60

Last Sync Time:

Time Zone: (GMT+09:00) Osaka, Sapporo, Tokyo

Daylight Saving Time: Disable

Current Date and Time

Displays the date and time set in the camera.

Settings

It is possible to change the date and time setting method, time zone and daylight saving time set at the initial setting.

[Settings Method]

Select the date and time setting method.

[Set manually]

Set the desired date and time in [Date] and [Time].

Set the time in 24-hour format in <hour:minute:second> order.

[Synchronize with NTP server]

Synchronizes the camera's time with the time of NTP server specified in the [Set NTP Server Settings Automatically] which appears.

[Set NTP Server Settings Automatically]

Select one of the following setting methods:

[Disable]

Enter the IP address or host name of the NTP server in [NTP Server].

[Use DHCP]

Synchronizes the camera's time with the time of the NTP server whose address is acquired from the DHCP server. The acquired NTP server address is displayed in [NTP Server (DHCP)].

For this setting, it is necessary to set [System] > [Communication] > [Network] > [IPv4] > [IPv4 Address Settings Method] to [Auto (DHCP)] (P. 65).

[Use DHCPv6]

Synchronizes the camera's time with the time of the NTP server whose address is acquired from the DHCPv6 server. The acquired NTP server address is displayed in [NTP Server (DHCPv6)].

For this setting, it is necessary to set [System] > [Communication] > [Network] > [IPv6] > [IPv6] to [Enable], then set [Auto (DHCPv6)] to [Enable] (P. 66).

[Use DHCP/DHCPv6]

Synchronizes the camera's time with the time of the NTP server whose address is acquired from the DHCP server or DHCPv6 server.

If the NTP server address can be acquired from both the DHCP server (IPv4) and DHCPv6 server, the NTP server address acquired from the DHCP server (IPv4) will be used.

[Synchronization Interval (minutes)]

Enter the query interval for the set NTP server.

[Last Sync Time]

Displays the time last synchronized with the set NTP server.

[Synchronize with computer time]

Synchronizes the date and time with the time of the computer currently accessing the camera. After clicking [Apply],

[Settings Method] will change to [Set manually].

[Time Zone] is not automatically selected, so set it if necessary.



Note

If the connection with the NTP server cannot be established, for example because the IP address of the NTP server is incorrect, the [Last Sync Time] will not be updated or will be left blank.

[Time Zone]

Select the appropriate GMT (Greenwich Mean Time) time difference.

When the time zone is changed and [Apply] is selected, the date and time will be automatically changed based on the selected time zone.

[Daylight Saving Time]

Select whether to automatically adjust for daylight saving time according to the time zone.

[System] > [System] > [Environment]

Settings for the frame frequency.

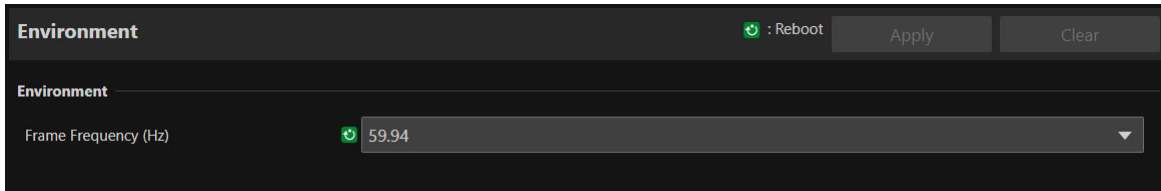

Environment

Setting the frame frequency.

[Frame Frequency (Hz)]

It is possible to change the frame frequency set in the initial settings. The choices of the HDMI/SDI output signal format and the frame rate of the IP streaming video are determined according to the frame frequency. Also, since the choices of [Exposure] > [Shutter Mode] > [Slow (sec.)] could change, confirm the settings of the presets if any.

[System] > [Maintenance] > [General]

Checking camera information such as the firmware version, and performing maintenance on the camera system.

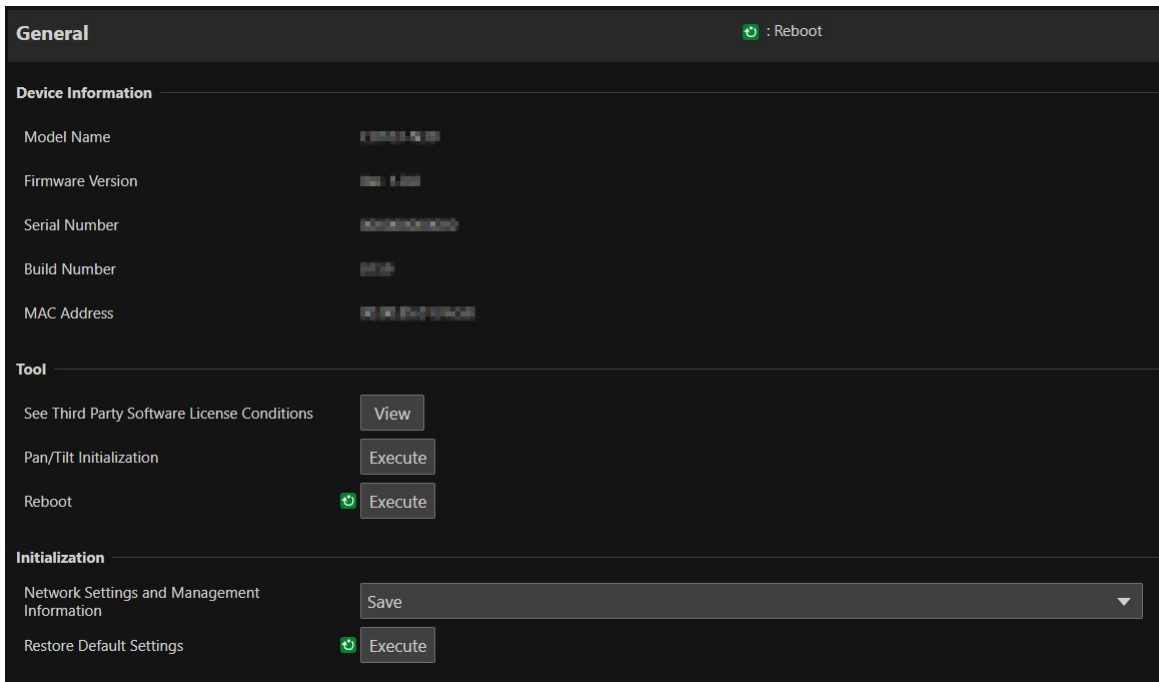

Device Information

[Model Name], [Firmware Version], [Serial Number], [Build Number], [MAC Address]

Displays information about the camera.

Tool

Displays license, initializes the pan/tilt settings, and reboots the camera.

[See Third Party Software License Conditions]

Displays the third party software license information as a list.

[Pan/Tilt Initialization]

If the pan/tilt position shifts, click [Execute] to initialize the position.

[Reboot]

Reboots the camera.

Initialization

Initializing the camera.

Important

- Do not turn off the power to the camera while performing [Restore Default Settings]. Turning off the camera may prevent the camera from starting correctly.
- Once [OK] is clicked, the process of restoring the default settings cannot be interrupted.

[Network Settings and Management Information]

When set to [Save], initialization will be performed except for the following settings.

- Network Settings
- NTP Server
- HTTP Server
- Host Access Restrictions
- Time Zone
- Certificates
- SSL/TLS
- Administrator Name
- Administrator Password

When set to [Do not save], initialization will be performed all the settings excluding camera's date and time, Add-On applications, and licenses.

Since the network settings will be initialized, it will not be possible to connect to the camera. Use the Camera Search Tool to configure the default settings.

[Restore Default Settings]

After rebooting, according to the setting in [Network Settings and Management Information] to restore the default settings.



Note

- Before clicking [Execute] in [Restore Default Settings], it is recommended to back up the current settings.
- It is possible to restore the factory default settings by using the RESET switch, but be aware that all the settings except the camera date and time will be restored to the factory default settings (P. 106).

[System] > [Maintenance] > [Backup/Restore]

Saving/Restoring all the camera settings.

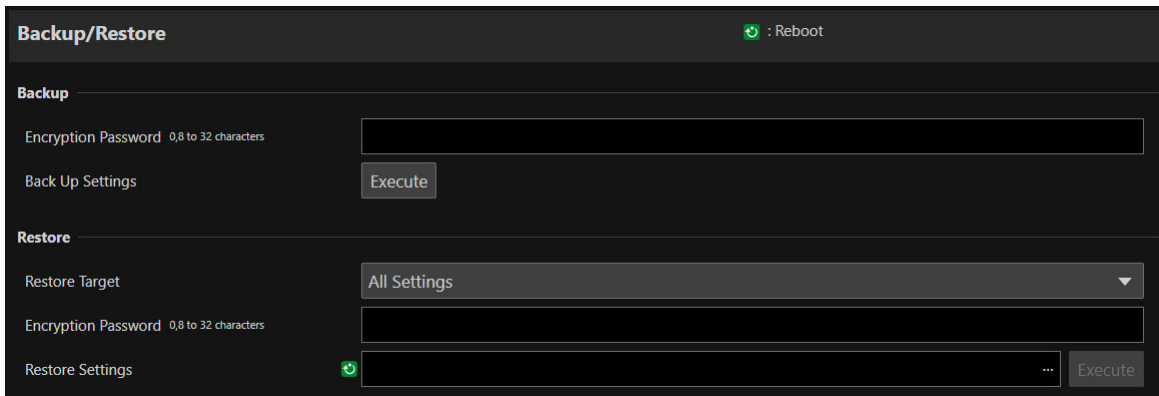

Important

Do not turn off the power to the camera while performing [Back Up Settings] or [Restore Settings]. Turning off the camera may prevent the camera from operating correctly.

Backup

Settings related to backup.

[Encryption Password]

It is possible to set a password for backup and restore. This password is for encrypting the backup data itself. Use at least two types of alphanumeric characters, numbers, or symbols.

When restoring from encrypted backup data, enter the password set when backing up.

[Back Up Settings]

All settings except date and time will be backed up. The administrator account and certificates used in SSL/TLS, including private key will be backed up.

Note

The settings are not restored if the password set when backing up and the password set when restoring do not match.

Restore

Settings related to restoring.

[Restore Target], [Restore Settings]

Selects the target settings to be restored from the backup file created in [Back Up Settings].

If [Other than Network Settings and Management Information] is selected, settings other than network settings, registered user information, time zone, administrator information, certificates, and access restrictions are restored.

After restoring, the camera will be rebooted.

Important

- Be aware that if restored from a backup file of another camera, problems such as duplication of addresses on the network or overwriting of a different Administrator Password may occur, preventing the connection to the camera.
- When restoring the settings, do not use a backup file created with a newer version of firmware than that of the camera to restore.

[Encryption Password]

Same as for [Backup].

[System] > [Maintenance] > [Update Firmware]

Updating the firmware.

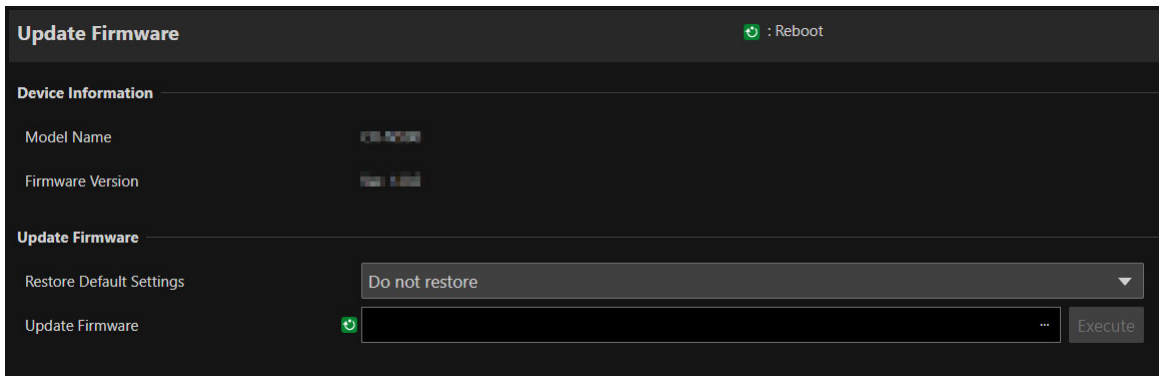

Update Firmware Reboot

Device Information

Model Name [REDACTED]

Firmware Version [REDACTED]

Update Firmware

Restore Default Settings: Do not restore

Update Firmware Execute

Device Information

[Model Name], [Firmware Version]

Displays the camera information.

Update Firmware

Updating the firmware.

Important

Do not turn off the power to the camera while performing [Update Firmware]. Turning off the camera may prevent the camera from operating correctly.

[Restore Default Settings]

Restores the default settings when the firmware is updated.

When set to [Restore], initialization will be performed except for the following settings.

- Network Settings
- NTP Server
- HTTP Server
- Host Access Restrictions
- Time Zone
- Certificates
- SSL/TLS
- Administrator Name
- Administrator Password
- Add-On Applications and Licenses

Note

You can back up/restore settings using [System] > [Maintenance] > [Backup/Restore] on the Settings Page (P. 90).

[Update Firmware]

Click [...] to select the firmware file for updating and click [Execute]. When a confirmation message is displayed, click [OK] to start Update Firmware. The POWER lamp on the rear of the camera blinks during the update.

After the firmware is updated, the camera will be rebooted.

[System] > [Maintenance] > [Log]

Displaying and downloading log messages.

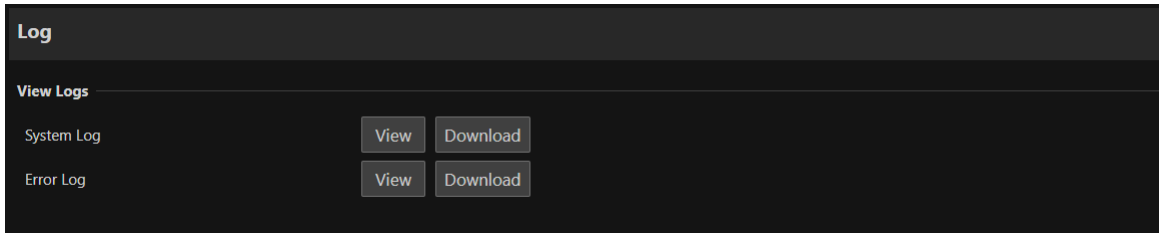

View Logs

Displays the history of camera operation and connection.

[System Log], [Error Log]

When [View] is clicked, displays log messages since the camera was turned on.

When [Download] is clicked, the message list can be downloaded as a file.

For details on log messages, refer to "List of Log Messages" (P. 96).

Chapter 4

Appendix

This chapter explains the measures to take when trouble occurs or a log message is displayed during camera use.

It also explains how to reset the camera to the factory default settings, major specifications and camera security measures.

Troubleshooting

Before contacting the dealer or a Canon sales representative, check the following items. If a log message is displayed, check the details of the message and the corresponding countermeasures in the log message list.

Note

A problem caused by the security software may occur. Configure to exclude the camera, or the software where the problem occurred, in the security software.

Problem	Countermeasures
The camera does not launch.	<ul style="list-style-type: none"> • If a PoE++ supported hub is being used, check if the LAN cable is connected correctly. • When using a DC power supply, make sure that all cables from the power supply to the camera are connected properly. If it still does not start up, make sure that 12 V DC is supplied correctly. • Turn the camera off and restart (P. 16). • Some PoE++ supported hubs limit the power used per port or the total power consumed by each port. If the limit is exceeded, it may not start, so check the instructions of PoE++ supported hub for use. • Check if there is no blackout at the site.
Settings Page is not displayed.	<ul style="list-style-type: none"> • Check if the LAN cable is connected correctly. • Check if the network to which the camera is connected is set up correctly. In particular, check if the IP address, subnet mask and default gateway address are set within the ranges supported by the applicable network. • If the IP address was changed, the new address will not become effective until the camera is rebooted. • Check if the correct URI (camera IP address) is entered in the web browser. • Check whether the connection is from a computer whose access is blocked in [System] > [Security] > [Host Access Restrictions] (P. 78). • Configure to exclude the camera, or the software where the problem occurred, in the security software.
The camera cannot be operated from the remote controller that supports Standard Communication (Serial).	<ul style="list-style-type: none"> • RS-422 connection is not working correctly. Check the connection to the RS-422 terminal and the wiring of the RS-422 cable. • The settings of serial connection on the remote controller and on the Settings Page are different. Select [System] > [Communication] > [External Connection (Serial)], check [Serial Device Address], and set the camera number to the same as that of the remote controller. Also set Baud Rate (9600 bps or 38400 bps) to the same setting.
Pan/tilt cannot be operated.	<ul style="list-style-type: none"> • External factors such as strong wind and obstacles are considered. Remove the cause of the error, and then retry the operation.
Pan/tilt does not operate as intended.	<ul style="list-style-type: none"> • Check if the pan/tilt movement range is limited in [System] > [Video and Audio] > [Movement Range].
There is no audio during IP distribution.	<ul style="list-style-type: none"> • If there is no audio, check the settings in [System] > [Video and Audio] > [Audio] as well as the sound and audio device settings for the computer. • Audio cannot be heard on the Settings Page.
There is no video or audio on the external monitor during HDMI/SDI output.	<ul style="list-style-type: none"> • The camera is not properly connected to an external monitor. Check the cable connections, and disconnect and connect the cable, or turn the camera off and restart. • Set the external monitor according to the output signal of the camera. • Check if [System] > [Video and Audio] > [Audio] > [Audio Input] is set to [Enable].
The sound is distorted or reduced.	<ul style="list-style-type: none"> • Shooting near loud sounds (fireworks, concerts, etc.) may distort or make the sound smaller than it actually is. In [System] > [Video and Audio] > [Audio] > [General Audio] > [Input Volume], adjust the volume of the input audio.
Forgot the administrator password.	<ul style="list-style-type: none"> • It is possible to initialize all settings of the camera excluding date and time using the RESET switch (P. 106). After performing initialization, use the Camera Search Tool to register the administrator account again. The IP address and subnet mask, etc. also need to be set again because the network settings are initialized.
The tally lamp does not light.	<ul style="list-style-type: none"> • In [System] > [System] > [Camera], set [Tally Lamp Control] to [Enable].

Problem	Countermeasures
The POWER lamp (orange) on the rear of the camera blinks.	<ul style="list-style-type: none"> • The firmware of the camera is being updated. It may take a while. • The pan/tilt position is shifted. Executing [Pan/Tilt Initialization] in [System] > [Maintenance] > [General] > [Tool] initializes the pan/tilt position. • If the POWER lamp (orange) continues to blink after taking any of the above measures, it may be a malfunction with the camera. Restart the camera. If the problem persists, please contact the dealer or a Canon sales representative.
Out of focus.	<ul style="list-style-type: none"> • When autofocus is used to control the focus, some subjects may be difficult to focus on automatically. If this happens, adjust the focus manually. • If the lens protector is dirty, clean it. For details, refer to "Routine Maintenance" (P. 23).
Subject appears bent diagonally.	<ul style="list-style-type: none"> • When shooting a fast-moving subject or when the angle of view changes during shooting, the subject may appear to be bent diagonally. This is a phenomenon that occurs when a CMOS image sensor is used, and is not a camera malfunction.
The image rotates in the opposite direction to the camera operation.	<ul style="list-style-type: none"> • Make sure [System] > [System] > [Camera] > [Installation Conditions] is set to [Video Flip] correctly (P. 80). • If connecting to a remote controller, the setting of the controller may be reverse. For details, refer to the instruction manual of controller.
Files cannot be saved.	<ul style="list-style-type: none"> • Operation System prohibits saving to certain folders. Accordingly, an attempt to save a file may fail. Specify other folders such as [Documents], [Pictures], etc.

List of Log Messages

Log Messages on the Camera

The list of log messages displayed in [System] > [Maintenance] > [Log] > [View Logs] on the Settings Page (P. 92). Log messages are classified into the following types.

Category	Level	Code	Fault level
crit	Error	4xx	Software-level failure (Task operations will stop)
err	Error	3xx	Operational error (Operations will continue)
warning	Warning	2xx	Non-operational error
notice	Warning	1xx	Error outside of the system
info	Information	0xx	Information on normal operation



Note

If no content is recorded in a log for approximately two hours, "--MARK--" will be recorded in the message area.

Error Log

System Error

S303 Error on saving settings [err]

Description	Can't update files of system settings (S303)
Meaning	An error generated while the system was saving a setting. Can't update system settings.
Countermeasure	If the error is detected after rebooting, initialize to the factory default settings. If the problem persists, contact the dealer.

S320 PAN/TILT operation error [err]

Description	%1 error occurred. [%2] (S320)
%1	PAN TILT
%2	Error details
Meaning	An error occurred during operation or stopping of pan/tilt.
Countermeasure	Follow the steps below to take measures. 1. First, check if there is something inhibiting the pan/tilt operation such as the case camera's head unit is in contact with something. Then operate the pan/tilt. 2. Execute [Pan/Tilt Initialization]. 3. Restart the camera. 4. If the problem is not resolved after taking the measures from 1 to 3 above, contact the dealer as there is a possibility of malfunction.

S327 PAN/TILT stop error [err]

Description	(S327)
Meaning	An error occurred with the pan/tilt during rebooting.
Countermeasure	If pan/tilt cannot be operated after rebooting, contact the dealer as there is a possibility of malfunction.

S330 Broken fan [err]

Description	FAN does not rotate. (S330)
Meaning	The fan does not rotate or a significant decrease in speed is detected.
Countermeasure	If the error is still detected after rebooting, it may be a failure with the fan, so contact the dealer.

S332 Fan operation has failed [err]

Description	Cannot control FAN. (S332)
Meaning	IO is not available to control the fan.
Countermeasure	If the error is still detected after rebooting, it may be a failure with the fan, so contact the dealer.

S350 Error in resuming from or switching to standby [err]

Description	Failed to resume from standby or switch to standby (S350)
Meaning	Failed to resume from or switch to the standby status.
Countermeasure	If the error is still detected after rebooting, contact the dealer.

S360 Audio Video synchronize error [err]

Description	Audio Video synchronize error. (S360)
Meaning	Video/Audio synchronize error
Countermeasure	If the error is still detected after rebooting, it may be a failure, so contact the dealer.

S370 Thumbnail creation error [err]

Description	Can't create thumbnail (S370)
Meaning	There was an error when creating a thumbnail. Thumbnail cannot be saved.
Countermeasure	If still detected after restarting, it is necessary to initialize to factory settings, or contacting the dealer.

S430 Temperature sensor failure [crit]

Description	cannot get temperature (S430)
Meaning	Cannot get the temperature from the temperature sensor.
Countermeasure	If the error is still detected after rebooting, it may be a failure of the board, so contact the dealer.

■ Audio Server Error

B301 Audio device error [err]

Description	cannot use audio device for %1 [%2:%3] (B301)
%1	Send/Receive type (rx tx)
%2	Error type (open write flush)
%3	Error number
Meaning	Detected an error in the audio device.
Countermeasure	If the error is still detected, contact the dealer.

B402 Audio server initialization failed [err]

Description	wvaudio initialization error [%1] (B402)
%1	Error number
Meaning	The audio server could not be initialized. The audio server stops.
Countermeasure	If the error is still detected after rebooting, it may be a failure, so contact the dealer.

B403 Settings change failed [err]

Description	cannot set config [%1:%2] (B403)
%1	Error notification number
%2	Error number
Meaning	The settings could not be updated. The audio server stops.
Countermeasure	If the error is still detected after rebooting, it may be a failure, so contact the dealer.

■ Video Error

V400 Video input initialization error [crit]

Description	video %1 initialization failure - %2 (%3) (V400)
%1	Video number
%2	Process description
%3	Error details
Meaning	The video input function was stopped because the video input system could not be initialized.
Countermeasure	If the error is still detected after rebooting, it may be a failure, so contact the dealer.

V401 Video input command error [crit]

Description	video command error - %1 (V401)
%1	Process description
Meaning	The video input function was stopped because a video input command could not be processed. Or, it may not operate in the desired setting.
Countermeasure	If the error is still detected after rebooting, it may be a failure, so contact the dealer.

V402 Video input frozen [crit]

Description	video %1 stalled (V402)
%1	Video number
Meaning	The video input function was stopped because the video input from the camera stopped.
Countermeasure	If the error is still detected after rebooting, it may be a failure, so contact the dealer.

V403 Internal error in intelligent service [err]

Description	cannot work intelligent (%1)(%2)(%3). (V403)
%1	Error number
%2	Reason for error
%3	Error information
Meaning	An internal error occurred in intelligent service.
Countermeasure	If the error is still detected after rebooting, it may be a failure, so contact the dealer.

V404 Intelligent service startup error [crit]

Description	intelligent initialization error (%1)(%2). (V404)
%1	Error number
%2	Reason for error
Meaning	A startup error occurred in intelligent service.
Countermeasure	If the error is still detected after rebooting, it may be a failure, so contact the dealer.

V405 Internal error in intelligent service [crit]

Description	intelligent working error (%1)(%2). (V405)
%1	Error number
%2	Reason for error
Meaning	An internal error occurred in intelligent service.
Countermeasure	If the error is still detected after rebooting, it may be a failure, so contact the dealer.

■ Standard Communication (IP) Error

D401 Standard communication (IP) initialization failed [crit]

Description	Standard Com initialization error[%1] (D401)
%1	Error number
Meaning	Standard communication (IP) could not be initialized.
Countermeasure	If the error is still detected after rebooting, it may be a failure, so contact the dealer.

■ RTP Error

R401 RTP initialization failed [crit]

Description	RTP initialization error[%1] (R401)
%1	Error number
Meaning	RTP could not be initialized.
Countermeasure	If the error is still detected after rebooting, it may be a failure, so contact the dealer.

■ NDI|HX Error

P401 NDI|HX initialization failed [crit]

Description	NDI HX initialization error[%1] (P401)
%1	Error number
Meaning	NDI HX could not be initialized.
Countermeasure	If the error is still detected after rebooting, it may be a failure, so contact the dealer.

■ NU Error

N401 NU initialization failed [crit]

Description	NU initialization error[%1] (N401)
%1	Error number
Meaning	NU could not be initialized.
Countermeasure	If the error is still detected after rebooting, it may be a failure, so contact the dealer.

■ SRT Error

T401 SRT initialization failed [crit]

Description	SRT initialization error [%1] (T401)
%1	Error number
Meaning	SRT could not be initialized.
Countermeasure	If the error is still detected after rebooting, it may be a failure, so contact the dealer.

■ Output Tracking Data Error

F301 Output Tracking Data startup error [err]

Description	free-d initialization error [%1] (F301)
%1	Error number
Meaning	Output Tracking Data startup failed.
Countermeasure	If the error is still detected after rebooting, it may be a failure, so contact the dealer.

■ Add-On Error

A381 License date/time inconsistency detection error [err]

Description	Date/Time inconsistency was detected. (A381)
Meaning	License date/time inconsistency was detected.
Countermeasure	Contact the dealer because the license may be locked.

Warning Log

■ Audio Server Warning

B203 Audio message send failure [warning]

Description	audio message send error %1 [%2] (B203)
%1	Message type
%2	Error number
Meaning	Failed to send audio message.

B204 Audio message receive error [warning]

Description	audio message rcv error [%1:%2] (B204)
%1	Error notification number
%2	Reason for error
Meaning	Failed to receive audio message.

■ Camera Application Warning

C211 Camera control command overflow [warning]

Description	command queue overflowed (C211)
Meaning	The camera control command queue overflowed, and some commands were discarded.
Countermeasure	Send the camera control command again after a while.

C221 Preset recall during the washer operation [warning]

Description	Can't run preset, because washer is on. (C221)
Meaning	Preset was recalled during the washer operation.
Countermeasure	Recall the preset after the washer operation stops.

C222 Recall preset during the color bars output [warning]

Description	Can't run preset, because color bars is on. (C222)
Meaning	Preset was recalled during the color bars output.
Countermeasure	Turn off the color bars output and recall the preset again.

C231 Trace execution during the washer operation [warning]

Description	Can't run trace, because washer is on. (C231)
Meaning	Tracing was executed during the washer operation.
Countermeasure	Wait until the washer operation stops, then try executing trace again.

C232 Trace execution during the color bars output [warning]

Description	Can't run trace, because color bars is on. (C232)
Meaning	Tracing was executed during the color bars output.
Countermeasure	Turn off color bars output and try tracing again.

■ RTP Warning

R101 RTSP authentication failure [notice]

Description	RTSP Error: error_code=401: Unauthorized (R101)
Meaning	RTSP authentication failed.

R102 RTSP connection failure [notice]

Description	RTSP Error: error_code=%d: (R102)
%d	400: When an invalid RTSP request is received etc. 503: The maximum number of RTP connections has been exceeded, or a request for multiple session streaming with tunneling for the same stream has been received, etc.
Meaning	RTSP connection has failed.

R103 RTP session disconnected [notice]

Description	session closed: num_of_sessions=%1 (R103)
%1	Total number of sessions for clients
Meaning	The session was disconnected from the client due to a factor other than TEARDOWN. (For example, TCP FIN)

R104 RTP session deleted [notice]

Description	session removed: num_of_sessions=%1 (R104)
%1	Total number of sessions for clients
Meaning	The session was deleted due to errors. (Session Timeout or when an invalid RTSP request is received)

■ Add-On Warning

A111 Notice for application to be installed [notice]

Description	Incorrect Add-On installation package. (A111)
Meaning	The installation or update was canceled because an invalid application package was detected.
Countermeasure	Install the correct application.

A112 Camera firmware and application version inconsistency notice [notice]

Description	Mismatched Add-On framework version. (A112)
Meaning	The installation or update was canceled due to an ineligible version of the application.
Countermeasure	Verify the camera firmware and application version.

A113 Notice for application to be installed [notice]

Description	Add-On package version is older than current version. (A113)
Meaning	The update was canceled because the version of the application package is out of date.
Countermeasure	Install the latest application. To downgrade the currently installed application, first uninstall the application and then install the required version of the application. Please note that the application settings and license file will be deleted at that time.

A114 Application uninstallation notice [notice]

Description	Add-On application (%1) not stopped. (A114)
%1	Application name
Meaning	Update or uninstall canceled because the application is running.
Countermeasure	Close the application.

A115 Notice of application not supporting camera [notice]

Description	Mismatched platform. (A115)
Meaning	The installation or update was canceled because the application is not compatible with the device.

A116 Notice of application not supporting camera [notice]

Description	Add-On application does not support this device. (A116)
Meaning	The installation or update was canceled because the application is not compatible with the device.
Countermeasure	Contact the dealer and ask whether there is another way.

A117 Notice of free space in application area being insufficient [notice]

Description	No space left on device. (A117)
Meaning	The installation or update was canceled due to insufficient storage capacity.
Countermeasure	Delete an installed application with low priority.

A120 Application license file installation notice [notice]

Description	Add-On application (%1) not installed. (A120)
%1	Application name
Meaning	The license installation was canceled because the application is not installed.
Countermeasure	Check the combination of the application and the license file.

A121 Application license file notice [notice]

Description	Add-On license file (%1) incorrect. (A121)
%1	Application name
Meaning	The license installation or update was canceled because an invalid license was detected.
Countermeasure	Install the correct license file.

A122 Application license overwriting error [notice]

Description	Add-On license overwrite error. (A122)
Meaning	The update was canceled because a license combination that does not allow for updates was uploaded.

A125 Application license file uninstallation notice [notice]

Description	Add-On license (%1) not installed. (A125)
%1	Application name
Meaning	The license uninstallation was canceled because the license is not installed.
Countermeasure	Specify the correct license file.

A126 Password mismatch when restoring application settings [notice]

Description	Add-On config file password mismatch. (A126)
Meaning	The restoring process was canceled because the password for [Back Up Settings] and [Restore Settings] does not match.

A171 Number of applications registrable automatically exceeded [notice]

Description	Number of Add-On applications to register exceeded limit. (A171)
Meaning	Automatic startup registration was suspended because the upper limit for applications registrable for automatic startup was exceeded.
Countermeasure	Cancel the registration of one of the already registered automatic startup applications and then configure the automatic startup setting for the desired application again.

■ SRT Warning

T201 SRT connection failure [warning]

Description	SRT connection error: %1 (T201)
%1	caller connection: Connection error (in Caller mode)
Meaning	SRT connection has failed.

■ Output Tracking Data Warning

F201 Output Tracking Data transmission failure [warning]

Description	free-d message output error IP: %1 (F201)
%1	Destination IP address
Meaning	Tracking data transmission failed.

■ Video Warning

V201 Intelligent service message receiving failure [warning]

Description	intelligent message rcv error %1 (%2). (V201)
%1	Error number
%2	Reason for error
Meaning	Failed to receive intelligent service message.

Notification Log

■ System Notification

S001 System started [info]

Description	starting paramd (S001)
Meaning	Parameter management module started.

S002 System settings changed [info]

Description	Updated system settings. (S002)
Meaning	Settings which do not require rebooting were changed.

S020 Thumbnail creation module start/stop [info]

Description	%1 thumbnaild (S020)
%1	starting stopping
Meaning	Thumbnail creation module started/ stopped.

S050 IPv4 address assigned to wired LAN interface [info]

Description	IPv4 Address %1 %2 was assigned to the wired I/F (S050)
%1	Set IPv4 address
%2	from router for DHCPv4 address
Meaning	IPv4 address is set for wired LAN.

S051 IPv6 address assigned to wired LAN interface [info]

Description	IPv6 Address %1 %2 was assigned to the wired I/F (S051)
%1	Set IPv6 address
%2	from router for DHCPv6/RA address
Meaning	IPv6 address is set for wired LAN.

S054 IPv4 address for wired LAN interface is released [info]

Description	IPv4 Address %1 %2 was released from the wired I/F (S054)
%1	Released IPv4 address
%2	from router for DHCPv4 address
Meaning	IPv4 address assigned to wired LAN is released.

S055 IPv6 address for wired LAN interface is released [info]

Description	IPv6 Address %1 %2 was released from the wired I/F (S055)
%1	Released IPv6 address
%2	from router for DHCPv6/RA address
Meaning	IPv6 address assigned to wired LAN is released.

S070 Change to certificate [info]

Description	%1: succeeded to %2 certificate (S070)
%1	ssl
%2	generate import delete export
Meaning	A certificate was created/imported/deleted/exported.

S080 The power required to start the camera system is not supplied [info]

Description	Insufficient power to boot the camera system. (S080)
Meaning	The power required to start the camera system is not being supplied.
Countermeasure	Use a DC or PoE++ supported L2 switch as the power source.

■ HTTP Server Notification

H001 System started/stopped [info]

Description	%1 httpd (H001)
%1	starting stopping
Meaning	HTTP Server started/stopped.

H145 Authentication failure [notice]

Description	Authentication failed for %1, IP: %2 (H145)
%1	Implemented countermeasures against URL XSS vulnerability (Equivalent to ftpd)
%2	IP address
Meaning	Authentication failed.

■ wvhttp Notification

W001 System started/stopped [info]

Description	%1 wvhttp (W001)
%1	starting stopping
Meaning	wvhttp server started/stopped.

W030 Startup and shutdown of wvhttp client [info]

Description	%1%2 host=<Host>, user=<User>, prio=<Priority> (W030)
%1	W (wvhttp session) V (Session-less video client) N (Session-less event client)
%2	+: Connect, -: Disconnect
Meaning	The camera server client was connected or disconnected.

W031 Transmitted video data size [info]

Description	%1= host=<Host>, user=<User>, video=<Number of frames> (W031)
%1	W (wvhttp session) V (Session-less video client)
Meaning	When a client disconnected, the total data that was sent to the client is displayed in number of frames.

W103 Authentication failure [notice]

Description	Authentication failed, IP: <IP address> (W103)
Meaning	Authentication failed.

■ Audio Server Notification

B001 Audio server started/stopped [info]

Description	%1 audio. (B001)
%1	starting stopping
Meaning	The audio server started/stopped.

B101 Received unusual request [notice]

Description	%1 unusual request[%2] (B101)
%1	Client host IP address
%2	Unusual type (400 404)
Meaning	Refused the request due to command error (400) and parameter error (404).

■ Camera Application Notification

C001 Camera control module started/stopped [info]

Description	%1 camerad (C001)
%1	starting stopping
Meaning	The camera control module started/stopped.

C002 Camera application started/stopped [info]

Description	starting cameraappl (C002)
Meaning	The camera application started.

■ Video Notification

V001 Video server started/stopped [info]

Description	%1 video (V001)
%1	starting stopping
Meaning	The video server started/stopped.

V002 Intelligent service started/stopped [info]

Description	%1 intelligent. (V002)
%1	starting stopping
Meaning	The intelligent service started/stopped.

■ Standard Communication (IP) Notification

D001 Standard communication (IP) notification started/stopped [info]

Description	%1 Standard Com (D001)
%1	starting stopping
Meaning	The standard communication (IP) started/stopped.

■ RTP Notification

R001 RTP started/stopped [info]

Description	%1 RTP (R001)
%1	starting stopping
Meaning	The RTP started/stopped.

R002 RTSP PLAY request received [info]

Description	PLAY received: client_IP=%1, num_of_sessions=%2 (R002)
%1	Client IP address <ul style="list-style-type: none"> Displays "HTTP tunneling connection" if the streaming protocol is HTTP tunneling.
%2	Total number of sessions for clients
Meaning	RTSP PLAY request was received.

R003 RTSP TEARDOWN request received [info]

Description	TEARDOWN received: client_IP=%1, num_of_sessions=%2 (R003)
%1	Client IP address <ul style="list-style-type: none"> Displays "HTTP tunneling connection" if the streaming protocol is HTTP tunneling.
%2	Total number of sessions for clients
Meaning	RTSP TEARDOWN request was received.

■ NDI|HX Notification

P001 NDI|HX started/stopped [info]

Description	%1 NDI HX (P001)
%1	starting stopping
Meaning	The NDI HX started/stopped.

■ RTMP Notification

P011 rtmpcd started/stopped [info]

Description	%1 rtmpcd (P011)
%1	starting stopping
Meaning	rtmpcd has started/stopped.

P012 RTMP stream start [info]

Description	RTMP start: %1 (P012)
%1	success error
Meaning	Starting of RTMP stream succeeded/failed.

P013 RTMP stream stopped [info]

Description	RTMP stop: %1 (P013)
%1	normal setting disconnected
Meaning	RTMP stream stopped due to normal processing/change of settings/disconnection.

■ SRT Notification

T001 SRT started/stopped [info]

Description	%1 SRT (T001)
%1	starting stopping
Meaning	The SRT started/stopped.

T002 SRT delivery start [info]

Description	start SRT stream: IP=%1 (T002)
%1	Destination IP address
Meaning	SRT delivery started.

T003 SRT delivery stop [info]

Description	stop SRT stream: IP=%1 (T003)
%1	Destination IP address
Meaning	SRT delivery stopped.

■ Output Tracking Data Notification

F001 Output Tracking Data function start and stop [info]

Description	%1 free-d (F001)
%1	starting stopping
Meaning	Output Tracking Data function started/stopped.

F002 Tracking data transmission start and stop [info]

Description	%1 free-d message output IP: %2 (F002)
%1	start stop
%2	Destination IP address
Meaning	Tracking data transmission started/stopped.

■ Add-On Notification

A001 Application installation and uninstallation [info]

Description	Add-On application %1 (%2). (A001)
%1	Install Uninstall
%2	Application ID
Meaning	An application was installed/updated/uninstalled.

A002 License installation and uninstallation [info]

Description	Add-On license %1 (%2). (A002)
%1	Install Uninstall
%2	Application ID
Meaning	A license was installed/updated/uninstalled.

■ NU Notification

N001 NU started/stopped [info]

Description	%1 NU (N001)
%1	starting stopping
Meaning	The NU started/stopped.

Restoring to the Factory Default Settings

If the settings have been forgotten and want to set the camera from the beginning, restore to the factory default settings. It is recommended to use [System] > [Maintenance] > [Backup/Restore] on the Settings Page to create a backup file before restoring the factory default settings (P. 90).

Important

If restored to the factory default settings, the camera will be unable to connect because the administrator account is also initialized. Use the Camera Search Tool to configure the default settings.

Note

For the factory default settings, refer to P. 107.

Restoring to the Initial Settings from a Web Browser

Use [System] > [Maintenance] > [General] > [Initialization] > [Network Settings and Management Information] > [Do not save] on the Settings Page (P. 88).

Restoring to the Factory Default Settings with the RESET Switch on the Camera

If the IP address or the Administrator password on the camera is forgotten, operating the camera via the network is not possible. In this case, press the RESET switch located in the camera's receptacle unit (P. 14) to initialize the camera.

1 Turn the camera off.

The camera does not have a power switch. In order to turn the camera on or off, connect or disconnect the power supply cable.

2 Turn on the power while pushing the RESET switch, confirm that the POWER lamp lights up (green), and then release the RESET switch after about five seconds.

The RESET switch is located in a recessed area. Push the switch using the tip of a pointed object such as a clip. When the POWER lamp stops blinking (green), the reset procedure is complete.

Note

The Add-On applications and licenses will not be deleted (application setting values are initialized). If you want to delete them, press up the DIP SW (switch) (P. 14) number 1 and then perform the operation of step 2. When the reset completes, turn off the power and return the switch to its original position.

List of Factory Default Settings

Item	Factory default settings
<ul style="list-style-type: none"> Exposure 	
Shooting Mode	Full Auto
Infrared	Off
Enhanced ND Filter	Off
Iris Limit	On
Flicker Reduction	Off
Auto Slow Shutter	On
<ul style="list-style-type: none"> WB/Color 	
White Balance:R Gain	0
White Balance:B Gain	0
Color Matrix:Gain	0
Color Matrix:R-G	0
Color Matrix:R-B	0
Color Matrix:G-R	0
Color Matrix:Phase	0
Color Matrix:G-B	0
Color Matrix:B-R	0
Color Matrix:B-G	0
<ul style="list-style-type: none"> Image Quality 	
Gamma	Normal1 (Standard)
Color Space	BT.709 Gamut
Color Matrix	Video
<ul style="list-style-type: none"> Image Quality Details 	
Sharpness:Level	0
Sharpness:Limit	0
Noise Reduction	Auto
S/N Priority	Off
Black:Master Pedestal	0
Black:Master Black Red	0
Black:Master Black Blue	0
Black Gamma:Level	0
Black Gamma:Range	0
Black Gamma:Point	0
Knee:Activate	On
Knee:Automatic	On
Knee:Saturation	0
<ul style="list-style-type: none"> Focus 	
Focus Mode	AF
Face Detection AF	Face Det. & Tracking

Item	Factory default settings
AF Speed	Normal
AF Response	Normal
Focus Limit	Off
<ul style="list-style-type: none"> PTZ/IS 	
Digital Zoom	Off
Soft Zoom Control	Off
Pan/Tilt Acceleration	Medium
Image Stabilizer	Standard
<ul style="list-style-type: none"> Preset 	
Speed Specification	On
Speed Mode	Time
Time (sec.)	2 seconds
Freeze Image During Movement	Off
<ul style="list-style-type: none"> Other Functions 	
Color Bars	Off
AUX OUT	Off
AUX IN	-

System

Item	Factory default settings
<ul style="list-style-type: none"> HDMI/SDI 	
Video Output Configuration	1920x1080/59.94P
<ul style="list-style-type: none"> SDI 	
3G-SDI Mapping	Level A
Time Code Output	Enable
<ul style="list-style-type: none"> Mainstream 	
Video Codec	H.264
Video Size	1920x1080
Framerate (fps)	59.94
Bit Rate Control	VBR
Target Bit Rate (Mbps)	20
I Frame Interval (sec.)	1.0
<ul style="list-style-type: none"> Substream 1 	
Video Codec	H.264
Video Size	640x360
Framerate (fps)	29.97
Bit Rate Control	VBR
Target Bit Rate (Mbps)	6
I Frame Interval (sec.)	1.0

Item	Factory default settings
<ul style="list-style-type: none"> Substream 2 	
Video Codec	JPEG
Video Size	1280x720
Framerate (fps)	14.99
<ul style="list-style-type: none"> General Audio 	
Audio Input	Disable
<ul style="list-style-type: none"> Pan/Tilt 	
Movement Limit	Disable
<ul style="list-style-type: none"> HTTP Server 	
Authentication Method	Digest Authentication
HTTP Port	80
HTTPS Port	443
<ul style="list-style-type: none"> Video Server 	
Maximum Number of Clients	15
Maximum Connection Time (sec.)	0
<ul style="list-style-type: none"> RTP Server 	
RTP	Enable
RTSP Authentication Method	Digest Authentication
RTSP Port	554
<ul style="list-style-type: none"> Audio Settings 	
Audio Compression Method	AAC-LC 48kHz
Multicast Address	0.0.0.0
Multicast Port	0
Multicast TTL	1
<ul style="list-style-type: none"> RTP Mainstream 	
Video Type	H.264 1920x1080
Multicast Address	0.0.0.0
Multicast Port	0
Multicast TTL	1
Audio Transmission	Disable
<ul style="list-style-type: none"> RTP Substream 1 	
Video Type	H.264 640x360
Multicast Address	0.0.0.0
Multicast Port	0
Multicast TTL	1
Audio Transmission	Disable

Item	Factory default settings
<ul style="list-style-type: none"> RTP Substream 2 	
Video Type	JPEG 1280x720
Multicast Address	0.0.0.0
Multicast Port	0
Multicast TTL	1
Audio Transmission	Disable
<ul style="list-style-type: none"> LAN 	
Maximum Packet Size	1500
<ul style="list-style-type: none"> IPv4 	
IPv4 Address Settings Method	Auto (DHCP)
AutoIP	Enable
IPv4 Address (AutoIP)	-
<ul style="list-style-type: none"> IPv6 	
IPv6	Enable
Auto (RA)	Enable
Auto (DHCPv6)	Enable
IPv6 Address (Manual)	(Blank)
Prefix Length	64
IPv6 Default Gateway Address	(Blank)
IPv6 Address (Auto)	-
<ul style="list-style-type: none"> DNS 	
Name Server Address 1	(Blank)
Name Server Address 2	(Blank)
Set Name Server Address Automatically	Use DHCP/DHCPv6
Host Name	(Blank)
Search Domain	(Blank)
Search Domain List	(Blank)
<ul style="list-style-type: none"> mDNS 	
mDNS	Enable
<ul style="list-style-type: none"> Standard Communication (IP) 	
Standard Communication (IP)	Enable
Response Port Number	Specified Port Number (52381)
Camera IP Settings Inquiry	Allow
Camera IP Settings Network Settings	Do Not Allow
<ul style="list-style-type: none"> NDI HX 	
NDI HX	Disable
<ul style="list-style-type: none"> RTMP 	
RTMP	Disable
<ul style="list-style-type: none"> Output Tracking Data 	
Output Tracking Data	Disable

Item	Factory default settings
<ul style="list-style-type: none"> SRT SRT	Disable
<ul style="list-style-type: none"> Serial Port Protocol Serial Port Connection Type Data Length (bit) Start Bit (bit) Stop Bit (bit) Parity	NU RS422 8 1 1 None
<ul style="list-style-type: none"> Server Certificate Management Server Certificates Server Certificate Password Server Certificate List <ul style="list-style-type: none"> Create Certificate Country (C) State/Province (ST) Locality (L) Organization (O) Organizational Unit (OU) Common Name (CN) Validity Period Start Date Validity Period End Date	(Blank) (Blank) (Blank) (Blank) (Blank) (Blank) (Blank) (Blank) (Blank) (Blank) (Blank) (Blank)
<ul style="list-style-type: none"> Encrypted Communications HTTPS Connection Policy <ul style="list-style-type: none"> Server Certificates Server Certificates	HTTP and HTTPS (Blank)
<ul style="list-style-type: none"> Administrator Account Administrator Name Password Confirm Password <ul style="list-style-type: none"> Authorized User Account User Name Password Confirm Password User List <ul style="list-style-type: none"> User Authority Authorized User Guest User	(Blank) (Blank) (Blank) (Blank) (Blank) (Blank) (Blank) (Blank) Camera Control <input checked="" type="checkbox"/> Video Distribution <input checked="" type="checkbox"/> Camera Control <input checked="" type="checkbox"/> Video Distribution <input checked="" type="checkbox"/>
<ul style="list-style-type: none"> IPv4 Host Access Restrictions Apply Host Access Restrictions	Disable

Item	Factory default settings
<ul style="list-style-type: none"> IPv6 Host Access Restrictions Apply Host Access Restrictions	Disable
<ul style="list-style-type: none"> Camera Name Camera Name <ul style="list-style-type: none"> Installation Conditions Video Flip <ul style="list-style-type: none"> Camera Control Auto Flip Freeze Image During Preset Movement (Default Value) Zoom Speed Steps Focus Speed Steps <ul style="list-style-type: none"> Color Bars Color Bar Type <ul style="list-style-type: none"> AUX OUT Operation Mode <ul style="list-style-type: none"> Tally Lamp Tally Lamp Control Tally Lamp Brightness	Camera Disable Enable Disable 128 64 SMPTE Normally Open Enable Medium
<ul style="list-style-type: none"> Add-On Management Add/Update Add-On List	(Blank) (Blank)
<ul style="list-style-type: none"> Genlock Genlock	Disable
<ul style="list-style-type: none"> Current Date and Time <ul style="list-style-type: none"> Settings Settings Method Time Zone Daylight Saving Time	Set manually (GMT+09:00) Osaka, Sapporo, Tokyo Disable
<ul style="list-style-type: none"> Environment Frame Frequency (Hz)	59.94
<ul style="list-style-type: none"> Initialization Network Settings and Management Information	Save
<ul style="list-style-type: none"> Backup/Restore Encryption Password Restore Target Encryption Password Restore Settings	(Blank) All Settings (Blank) (Blank)
<ul style="list-style-type: none"> Update Firmware Restore Default Settings	Do not restore

Specifications

For the latest information on this product (firmware and software, user manuals, operating environment, etc.), refer to the Canon website.

CR-X300 Main Unit

■ Camera

Image Sensor	Type 1/2.3 (1/2.3 in.) single-plate CMOS sensor Total pixels: approx. 21.14 megapixels Effective pixels: approx. 8.29 megapixels (3840 x 2160)	
Lens	f=3.67 – 73.4 mm, F/1.8 – 2.8, 20x optical zoom 35mm equivalent focal length: [Frame Frequency 29.97/25.00/23.98 Hz] approx. 29.3 (W) – 601 mm (T) [Frame Frequency 59.94/50.00 Hz] approx. 30.5 (W) – 627 mm (T) 8-bladed circular aperture 12 elements in 10 groups (including 2 aspheric elements)	
Digital Zoom	20x	
Minimum Focusing Distance	1 cm (0.39 in.) at maximum wide angle, 60 cm (2.0 ft.) throughout the zoom range (from the lens protector)	
Angle of View	[Frame Frequency 29.97/25.00/23.98 Hz] Horizontal: 65.6° (W) – 3.6° (T) Vertical: 39.8° (W) – 2.0° (T) [Frame Frequency 59.94/50.00 Hz] Horizontal: 63.5° (W) – 3.4° (T) Vertical: 38.4° (W) – 1.9° (T)	
Shutter Speed	1/6 – 1/2000 sec. (specific values depend on the frame frequency)	
Focus	Focus mode: Manual, Continuous AF, Face Detection AF, Tracking AF type: Hybrid AF, Contrast AF	
Shooting Mode	F.Auto, P, Tv, Av, M	
	Scene Mode	Portrait, Sports, Low light, Spotlight
Custom Picture	Gamma	Normal1, Normal3
	Color Space	BT.709, BT.2020
	Color Matrix	Neutral, Video
ND Filter	ND filter: 1/8 at maximum Enhanced ND filter: 1/32	
IR Mode	Electrically switchable	
Image Stabilizer	Optical-shift (Standard IS, Powered IS)	
White Balance	AUTO (AWB), Set A, Set B, preset settings (daylight: approx. 5600 K*, tungsten lamp: approx. 3200 K*), color temperature setting (2000 K – 15000 K), Manual * Color temperatures are given for reference purposes only. Color temperature and color compensation (CC) adjustment available for all settings except custom white balance and AWB.	
Gain	0.0 – 36.0 dB	
Min. Subject Illumination	Approx. 3.0 lux (shutter speed 1/60 sec., frame frequency 59.94 Hz (P (Program AE) shooting mode), auto slow shutter "Off")	
Video Flip	Supports upright/ceiling installation, flip function ("Auto Flip" enabled/disabled)	
Built-in Microphone	Waterproof microphone	

■ Server

Video Output Signal	SDI	<p>3840 x 2160: 29.97P, 25.00P, 23.98P (4:2:2 10 bit) 1920 x 1080: 59.94P/59.94i, 50.00P/50.00i/25.00P, 29.97P/23.98P (4:2:2 10 bit) 1280 x 720: 59.94P, 50.00P (4:2:2 10 bit)</p> <ul style="list-style-type: none"> - Same video format required for SDI and HDMI (cannot select different formats for SDI and HDMI) - When 3840 x 2160 is selected for SDI, video will not be outputted to HDMI.
	HDMI	<p>3840 x 2160: 29.97P, 25.00P, 23.98P (4:2:2 10 bit) 1920 x 1080: 59.94P/59.94i, 50.00P/50.00i/25.00P, 29.97P/23.98P (4:2:2 10 bit) 1280 x 720: 59.94P, 50.00P (4:2:2 10 bit)</p> <ul style="list-style-type: none"> - Same video format required for SDI and HDMI (cannot select different formats for SDI and HDMI) - When 3840 x 2160 is selected for HDMI, video will not be outputted to SDI.
	IP	<p>Frame Frequency 59.94 Hz 1920 x 1080: 59.94 fps, 29.97 fps, 14.99 fps, 5.00 fps (4:2:0 8 bit) 1280 x 720: 59.94 fps, 29.97 fps, 14.99 fps, 5.00 fps (4:2:0 8 bit) 640 x 360: 59.94 fps, 29.97 fps, 14.99 fps, 5.00 fps (4:2:0 8 bit)</p> <p>Frame Frequency 29.97 Hz 3840 x 2160: 29.97 fps, 14.99 fps, 5.00 fps (4:2:0 8 bit) 1920 x 1080: 29.97 fps, 14.99 fps, 5.00 fps (4:2:0 8 bit) 1280 x 720: 29.97 fps, 14.99 fps, 5.00 fps (4:2:0 8 bit) 640 x 360: 29.97 fps, 14.99 fps, 5.00 fps (4:2:0 8 bit)</p> <p>Frame Frequency 50.00 Hz 1920 x 1080: 50.00 fps, 25.00 fps, 12.50 fps, 5.00 fps (4:2:0 8 bit) 1280 x 720: 50.00 fps, 25.00 fps, 12.50 fps, 5.00 fps (4:2:0 8 bit) 640 x 360: 50.00 fps, 25.00 fps, 12.50 fps, 5.00 fps (4:2:0 8 bit)</p> <p>Frame Frequency 25.00 Hz 3840 x 2160: 25.00 fps, 12.50 fps, 5.00 fps (4:2:0 8 bit) 1920 x 1080: 25.00 fps, 12.50 fps, 5.00 fps (4:2:0 8 bit) 1280 x 720: 25.00 fps, 12.50 fps, 5.00 fps (4:2:0 8 bit) 640 x 360: 25.00 fps, 12.50 fps, 5.00 fps (4:2:0 8 bit)</p> <p>Frame Frequency 23.98 Hz 3840 x 2160: 23.98 fps, 11.99 fps, 5.99 fps (4:2:0 8 bit) 1920 x 1080: 23.98 fps, 11.99 fps, 5.99 fps (4:2:0 8 bit) 1280 x 720: 23.98 fps, 11.99 fps, 5.99 fps (4:2:0 8 bit) 640 x 360: 23.98 fps, 11.99 fps, 5.99 fps (4:2:0 8 bit)</p> <ul style="list-style-type: none"> - JPEG has one pattern fixed depending on the frame frequency (format is fixed and cannot be selected) Resolution: 1280 x 720 When frame frequency is 59.94/29.97 Hz: 14.99 fps When frame frequency is 50.00/25.00 Hz: 12.50 fps When frame frequency is 23.98 Hz: 11.99 fps
Video Transmission Protocol	XC (Canon's original), RTSP/RTP, NDI HX, RTMP/RTMPS	
Control Protocol	XC (Canon's original), NU (Canon's original), NDI HX, Standard Communication (Serial), Standard Communication (IP), SRT, free-d	
Preset	Number of presets: Max. 100 (including home position)	

■ Interface

Communication Control	LAN, Serial
Network Terminal	LAN x 1, RJ45, 1000Base-T
6G-SDI OUT Terminal	BNC jack (output only) x 1, 0.8 Vp-p/75 Ω, unbalanced SMPTE 2081, 424, 425, ST 299-2 compliant Embedded audio, Time code (VITC/LTC)
GEN-LOCK Terminal	BNC jack x 1, 1.0 Vp-p/75 Ω, input only
HDMI OUT Terminal	HDMI connector x 1, output only
RS-422 Terminal	RJ45 connector x 1
External Device I/O Terminal	AUX connector x 1

■ Pan/Tilt Section

Pan-Tilt Head Operations	Operation Range	Pan operation range: Horizontal $\pm 180^\circ$ Tilt operation range: Vertical $-40^\circ - +215^\circ$
	Operation Speed	0.3° – 60°/sec.
	Position Accuracy	within $\pm 10'$
	Noise	NC45 or lower (when operating at 60°/sec.)
	Wiper	Equipped

■ Others

Operating Environment	Temperature/Humidity Resistance	$-15^\circ\text{C} - +40^\circ\text{C}$ ($+5^\circ\text{F} - +104^\circ\text{F}$), Humidity 90% or less (without condensation) (Startup temperature $-10^\circ\text{C} - +40^\circ\text{C}$ ($+14^\circ\text{F} - +104^\circ\text{F}$))
	Survival Wind Speed	15 m/sec.: Normal operation 30 m/sec.: Operation possible 60 m/sec.: Non destruction
Installation Method	Supports upright/ceiling installation	
Power Supply	PoE: PoE++ power supply via LAN connector (IEEE802.3bt compliant) – PoE and PoE+ cannot be used External power source: 12 V DC (Use the included power cable with DC plug)	
Power Consumption	PoE++ Input: Approx. 39.8 W* max. (body only) DC Input: Approx. 37.7 W max. (body only) * Class 5 (40.0 W required) for power supply devices	
Dimensions (W x H x D)	Approx. 217 x 311 x 217 mm (8.54 x 12.24 x 8.54 in.) (excluding protrusions and connector cover)	
Weight	Approx. 7 kg (15.5 lb.) (body only)	
Dust-resistant/Waterproof	IP65	
Supported Controllers	Hardware: RC-IP100, RC-IP1000 Software: Remote Camera Control Application	

Operating Environment

For either environment, setting conditions and video display/audio support is as follows.

- Must be configured to allow use of JavaScript, and web storage
- Only JPEG format is supported for displaying video
- Does not support audio

■ Settings Page (Computer Environment)

OS	Windows 11, Windows 10 64-bit	macOS 14
CPU	Intel Core i7-8700 or greater	
Memory	8 GB or more	
Web Browser	Microsoft Edge (Chromium) Google Chrome	Safari
Display	Resolution 1920 x 1080 or greater	

■ Settings Page (Verified Mobile Environment)

- As of April 2024

OS	iOS 17/iPadOS 17	Android 14
Web Browser	Safari	Google Chrome

Security Measures

If the camera is connected to a network and used, it may become a target of cyber attacks such as unauthorized access from unintended third parties. Since this camera has a variety of server functions built in, although they can be convenient, there is a risk of being attacked by a third party unless operated with security measures. To completely eliminate all risks is impossible, however, by studying various risk angles and taking measures based on the security policies, it is possible to decrease the risk of cyber attacks.

This section explains the security hardening measures to the camera settings. Refer to this section and implement necessary measures according to the environment under the customer's responsibility, which will lead to safer camera operation. System administrators are advised to read.

Important

To the full extent permitted by laws and regulations, neither Canon Inc. nor any of its subsidiaries or affiliates shall be liable for any losses, direct, incidental or consequential damages, or liabilities that may be incurred as a result of network security incidents such as unauthorized accesses.

The security hardening measures explained in this section are mainly for the cameras, which are a part of an entire system as shown in the figure below. For the entire system's security hardening, measures must be taken according to the customer's network environment and/or purpose of the camera use.

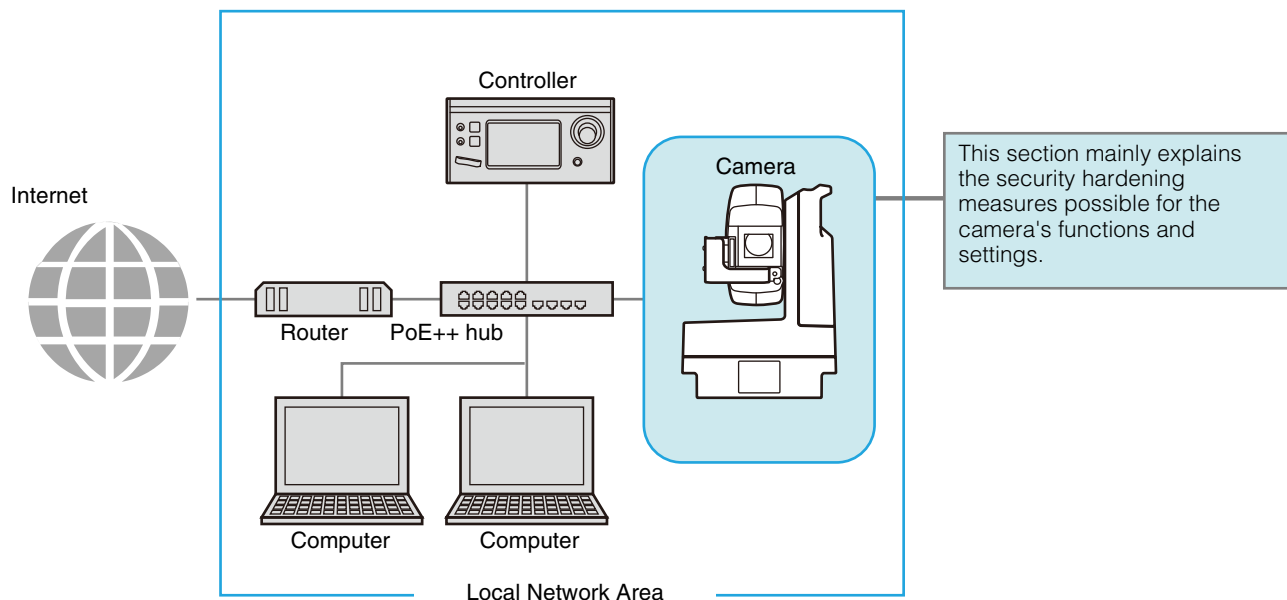

In order to reduce the security risk, it is effective to block access physically and/or virtually if it is unnecessary to be made accessible from an external network, such as the internet.

When access from a remote location is unnecessary and the devices accessing the camera can be limited, using only specific devices in the same local area network will enhance security. When it is necessary to access the camera from a remote location, it is important to use a method that can communicate safely, such as using a VPN (Virtual Private Network) that can block access from the outside.

Basic Measure 1: Setting Administrator Name and Password

The administrator account has authority over all of the camera's settings and operations. If the administrator account is illegally used by an unauthorized party and tampering is done, there is a risk the camera will not be accessible. In order to prevent spoofing of the administrator account, the most fundamental measure for safe operation of the camera is to make the administrator name and password in an array of letters that are difficult to guess by unauthorized users. Strictly manage the administrator account and refrain from settings such as the same administrator account on multiple cameras. The administrator account needs to be set when the camera is started for the first time. After setting, editing can be done on the camera's Settings Page (P. 77).

■ Setting a Strong Administrator Name and Password

In order to strengthen the administrator name and password, consider the following points:

- Combine at least 10 characters of alphanumeric characters or symbols and special characters permitted for the camera.
- Combine upper and lower case characters.
- Avoid commonly used words and string of characters that are easy to guess.

■ Other Passwords

For the camera, in addition to the administrator account, the password for Server Certificate (P. 74), Authorized User (P. 77), and Encrypting Backup Information (P. 90) are to be set. Set these passwords in an array of letters that are difficult to guess by unauthorized parties and manage them appropriately.

Basic Measure 2: Using the Latest Firmware

The camera's firmware is updated as needed in order to improve performance of the functions and bug fixes. From the security point of view, it is important to always keep it updated because the measures against known vulnerabilities are applied to the latest firmware.

Check Canon's website regularly at the initial setting after purchasing the camera and during its operation, whether the latest firmware is provided.

The firmware version can be confirmed and updated on the camera's Settings Page (P. 88, P. 91).

Basic Measure 3: Setting Date and Time

Set the correct date and time for the camera. It is recommended to set the time to an NTP server if connected to the Internet. If there are indications that suspicious unauthorized access occurred, it may be possible to confirm the date and time of occurrence by checking the log.

Date and time is set on the camera's Settings Page (P. 85).

Basic Measure 4: Monitoring the Log

Camera connection status and operating conditions are recorded and saved as a log in the camera embedded memory. Check the logs periodically to quickly find any signs of suspicious unauthorized access, such as repeated user authentication failures. For details on the log, refer to "List of Log Messages" (P. 96).

The logs will be deleted if any of the following operations are performed: rebooting, initialization, and restoring to the factory default settings.

The log will also be deleted if exceeding a certain size.

The log saved in the camera embedded memory can be confirmed on the camera's Settings Page (P. 92).

Measures Suitable to the Users' Environment 1: User Management

"Administrator", "authorized user", and "guest user" are the three types of accounts that are able to access the camera. The administrator account has authority over all of the camera's settings and operations. Only the administrator account can access the [System] menu on the Settings Page. Therefore, in order to prevent leaks to unauthorized users, it is important to strictly manage information on the administrator account.

In addition to the administrator, an authorized user and guest user with privileges granted can access the camera from a controller or access the Settings Page. The administrator should understand what an authorized user and guest user are able to do, and set the minimum necessary authorization level and users.

Authorized Users Means Users Who Require Authentication

To allow only specific users, except the administrator, to control the camera and deliver the video, set up an authorized user. In the authorized user settings, register account information (user name and password) and grant privileges (allow video distribution only, allow camera control, etc.). The same authority is given to all authorized users, therefore it is necessary to be careful to give authority to authorized users. Regularly review and manage the authorized users, and set the minimum necessary authorization level and users.

It is important to disable all the authorities of the guest users, which is described later, when wanting to restrict access to only authorized users. Unless these are disabled, access from the guest users will not be restricted.

Guest Users

Guest user means a guest account which does not need a user name and password. By enabling authorities for the guest users, anyone will be able to access the camera without requiring user authentication. Also, this would allow camera control and video distribution commands without authentication. Therefore, guest users authority should be set only when security is ensured, for example, if used within the network that prohibits the external access, etc., otherwise disable all authority of the guest users.

When allowing access by guest users, grant only the minimum necessary privileges to them, since the same privileges are given to all guest users, just as to all the authorized users.

User management is set on the camera's Settings Page (P. 76).

Measures Suitable to the Users' Environment 2: Host Access Restrictions

By specifying the hosts that can access the camera, the risk of unauthorized access can be reduced.

In order to restrict hosts to access the camera, allow communication with only specified hosts, and prohibit all other communication. Oppositely, there is also the method of prohibiting communication with specified hosts and allowing communication with all others.

Depending on the user's environment, the range of access restriction can be grouped on a network basis, or it can be set for each host. However, if mistakenly setting the administrator's IP address to prohibit communication, access from the administrator to the camera will be prohibited and there will be no other way than to restore to the factory default settings. Caution is needed when setting the access restrictions.

Host access restrictions are set on the camera's Settings Page (P. 78).

Measures Suitable to the Users' Environment 3: Setting to the Digest Authentication

When accessing the cameras via [HTTP Server] and [RTP Server], select [Digest Authentication] for the authentication method. When [Basic Authentication] is selected, the password can be easily leaked to unauthorized parties because the password will be sent on the network without being encrypted.

It is necessary to set the authentication method of the HTTP Server and the RTP Server respectively. Authentication method is set on the camera's Settings Page respectively (P. 62, P. 63). Confirm that the application supports the Digest Authentication.

Measures Suitable to the Users' Environment 4: Changing the Port Number

It is important to limit unspecified access to prevent unauthorized access to the camera. The port number is an entrance to the communication between the camera and the external device, and a number is set for each communication protocol. A common number is used for the port number and network devices can be connected easily. Thus, there is a risk of it being used for intrusion by unauthorized parties.

In case there is a need to change the port number due to concern of security, make sure that the port numbers are not redundant with those of other communication protocols, and set it within the specified range. If the port number is changed, specify the port number in addition to the IP address in order to access the camera.

Example: Changing the Port Number

When connecting by the HTTPS, set "https://{Camera's IP address}:{Port Number}".

When the HTTPS port number is changed to 10443

https://192.168.100.1:10443

HTTP Port Numbers/HTTPS Port Numbers

HTTP/HTTPS port number is set on the camera's Settings Page (P. 62).

It is also possible to change the following port numbers:

- RTSP Port (P. 63)
- Multicast Port (P. 63)

Measures Suitable to the Users' Environment 5: Encrypting Communication

In order to securely communicate between the camera and the external device, it is recommended that all communication be via HTTPS connection (encrypted communication combining SSL/TLS and HTTP). SSL (Secure Sockets Layer)/TLS (Transport Layer Security) is a technology to encrypt communication on the network and prevent hacking and tampering of communication contents by an unauthorized party. Even if the data is hacked during communication, by encrypting the communication in the proper way, the contents of the data are protected and safety can be secured.

Self-Signed Certificate and Server Certificate

To encrypt communication via HTTPS connection, use a self-signed certificate or a server certificate issued from a CA (Certificate Authority). Self-signed certificates are sufficient to do encryption, however, a warning screen will be displayed in the web browser, and there is a risk of impersonation. Therefore, it is advised to use it in the cases for an operation test and others.

It is recommended to acquire and install a server certificate issued from CA for a full-scale system operation.

Encrypting communications by HTTPS connection is set on the camera's Settings Page (P. 75).

Note

Even if setting the HTTPS connection as mentioned above, the video delivered via RTP/RTSP cannot be encrypted (SRT delivery can be encrypted). In order to securely communicate the video to deliver, it is necessary to deal with the whole system.

Measures Suitable to the Users' Environment 6: Disabling Unused Functions

The camera has functions to support various purposes and network environments. However, unless those functions are properly set, there is a risk of unauthorized access from outside parties. In order to use the camera safely, it is also necessary to disable the setting of unused functions.

The following describes the functions that need to be addressed in the operating environment and usage situation, such as enabling only the necessary functions or disabling the functions after the setting is completed.

AutoIP

When [AutoIP] (P. 66) is enabled, even in environments where there is no DHCP server, IPv4 link-local addresses (169.254.xxx.xxx) are assigned to the camera. Therefore, by assigning a computer to the same network as the IPv4 address and using the Camera Search Tool, the camera can be detected and initial settings can be made.

Although [AutoIP] is enabled by factory default settings, it is recommended to disable [AutoIP] when the initial setting of the network is completed so that it will not be used for unauthorized purposes.

mDNS (multicast Domain Name System)

[mDNS] (P. 67) is a function to notify devices on the network of the camera IP address and host name information simultaneously so that the camera can be detected even in an environment without a DNS server.

In the factory default settings, the setting of [mDNS] is enabled, but to prevent unauthorized use by third parties, disable it after the initial network settings are completed.

RTP (Real-time Transport Protocol)

By using [RTP Server] (P. 63), video and audio data can be delivered to the specified multicast address. It is recommended to set [RTP] to [Disable] when the devices connecting to the camera do not require RTP protocol.

Standard Communication (IP), NDI|HX, RTMP, Output Tracking Data, SRT

When using [Standard Communication (IP)], [NDI|HX], [RTMP], [Output Tracking Data] and [SRT], it is possible to distribute videos using each protocol, operate the camera, etc. (P. 68)

If it is unnecessary to connect the camera to a device using these protocols, set each item to [Disable].



Important

- [Video Distribution] under the [User Authority] (P. 77) is not reflected to the RTP.
- When using NDI|HX, RTMP, SRT or tracking data output, access control is disabled from the [User Management] (P. 76).

Precautions When Disposing the Camera

When disposing the camera, initialize the camera and delete all setting information such as network settings and administrator account.

For camera initialization, refer to Settings Page (P. 88). When disposing the camera, set [Network Settings] to [Do not save].

If unable to access the Settings Page, use the RESET switch on the camera to restore to the factory default settings.

Encrypting Backup Information

The backup information of the camera settings is used when restoring the camera to the user's previously saved settings. It is possible to manage the backup information more securely by setting [Encryption Password] for the backup information.

Handle the set password with care.

Backup information encryption is set on the camera's Settings Page (P. 90).

Index

A

Add-On	83
Administrator	76
Administrator account	77
AE Response	40
AE Shift	39
AF (Auto Focus)	46
AGC Limit	39
Appearance	114
Application	83
Audio	60
Audio settings (RTP)	63
Authorized user	76
Authorized user account	77
Auto Flip	81
Auto Slow Shutter	40
Autofocus	46
AUX IN	53
AUX OUT	53, 81

B

Backup/Restore	90
Bit Rate Control	59
Black	44

C

Camera housing	13
Camera name	80
Camera Search Tool	26
Certificate Management	74
Color Bars	53, 81
Color Matrix	41, 43
Color Space	43
Connector cover	21
Create certificate	74

D

Date and Time	85
Device information	88
Digital tele-converter	35
Digital zoom	35
DNS	66

E

Encrypted communications	75
Enhanced ND Filter	37
Environment	87
Error log	96
Exposure	36
External Connection (IP)	68
External Connection (Serial)	72

F

Face Detection AF	46
Factory default settings	106, 107
Firewall	25
Flicker Reduction	40
Focus	46
Frame Frequency (Hz)	87
Framerate	58

G

Gain (dB)	39
Gamma	43
General audio	60
Genlock	82
Guest user	76

H

Handle	13
HDMI/SDI	57
Host Access Restrictions	78
HTTP server	62

I

Image quality	43
Image quality details	44
Image Stabilizer	49
Infrared	37
Initial camera settings	26
Initialization	88
Installation conditions	80
IP Audio streaming	60
IP Streaming Video	58
IPv4	65
IPv4 host access restrictions	78

IPv6 host access restrictions	79
Iris (Aperture Value)	37
Iris Limit	40
IS (Image Stabilizer)	49

K

Knee	45
------------	----

L

LAN	65
Language	31
Lens protector	13
Log messages	96

M

Mainstream	58
Manual Focus	48
mDNS	67
Metering Mode	39
MF (Manual Focus)	48
Microphone	13
Movement Limit	61

N

Names of parts	13
ND Filter	38
NDI HX	68
Network	65
Noise Reduction	44
Notification log	102
NU	72

O

Operating environment	113
Other functions	53

P

Pan	34
Pan-tilt head	13
POWER lamp	14
Power ON	31
Preset	50
Protocol	72
PTZ	49

R

Receptacle unit	14
RESET switch	14, 106
RTMP	69
RTP server	63
RTP stream	64

S

S/N Priority	44
SDI	57
Security measures	116
Serial port	72
Server	62
Server certificate	75
Server certificate management	74
Settings Page	30
Sharpness	44
Shooting Mode	36
Shutter Mode	38
Soft Zoom Control	49
Specifications	110
SRT	70
SSL/TLS	75
Standard communication (IP)	68
Standard communication (serial)	73
Standby	31
Substream 1	59
Substream 2	59
System	54

T

Tally lamp	13, 31, 82
Tilt	34
Tripod	21
Troubleshooting	94

U

Update Firmware	91
User authority	77
User Management	76

V

Video Codec	58
Video server	62
Video Size	58
View logs	92

W

Warning log	99
Washer	53
WB (White Balance)	41
White Balance Mode	41
Wiper	13, 53

Z

Zoom	34
------------	----

