



# **MG3500 series Online Manual**

Read Me First  
Useful Functions Available on the Machine  
Overview of the Machine

# Contents

|   |    |
|---|----|
| Read Me First. . . . .  | 7  |
| How to Use the Online Manual. . . . .                                   | 8  |
| Trademarks and Licenses. . . . .  | 9  |
| Search Tips. . . . .  | 10 |
| Window Used in Operation Explanation. . . . .                           | 12 |
| Useful Functions Available on the Machine. . . . .                      | 13 |
| Useful Functions Available from Applications and the Main Unit. . . . . | 14 |
| Helpful Functions Available Through the Network. . . . .                | 17 |
| Online Storage Integration Function. . . . .                            | 21 |
| Printing with Google Cloud Print. . . . .                               | 22 |
| Preparations for Printing with Google Cloud Print. . . . .              | 23 |
| Printing from Computer or Smartphone with Google Cloud Print. . . . .   | 26 |
| Using Remote UI. . . . .  | 28 |
| Printing from AirPrint Compliant Device. . . . .                        | 31 |
| How to Use Print from E-mail. . . . .                                   | 35 |
| Preparing to Use Print from E-mail. . . . .                             | 40 |
| Timezone List. . . . .  | 43 |
| List of Function for Each Model. . . . .                                | 44 |
| Overview of the Machine. . . . .  | 46 |
| Safety Guide. . . . .   | 47 |
| Safety Precautions. . . . .   | 48 |
| Regulatory and Safety Information. . . . .                              | 49 |
| Main Components and Basic Operations. . . . .                           | 52 |
| Main Components. . . . .  | 53 |
| Front View. . . . .   | 54 |
| Rear View. . . . .  | 56 |
| Inside View. . . . .  | 57 |
| Operation Panel. . . . .  | 58 |
| About the Power Supply of the Machine. . . . .                          | 60 |
| Confirming that the Power Is On. . . . .                                | 61 |
| Turning the Machine On and Off. . . . .                                 | 62 |
| Notice for the Power Plug/Power Cord. . . . .                           | 63 |

|  |           |
|--|-----------|
| Notice for Unplugging the Power Cord. . . . .                              | 64        |
| <b>Loading Paper / Originals. . . . .</b>                                  | <b>65</b> |
| Loading Paper. . . . .   | 66        |
| Loading Plain Paper / Photo Paper. . . . .                                 | 67        |
| Loading Envelopes. . . . .   | 70        |
| Media Types You Can Use. . . . .   | 73        |
| Paper Load Limit. . . . .  | 75        |
| Media Types You Cannot Use. . . . .  | 77        |
| Printing Area. . . . .   | 78        |
| Printing Area. . . . .   | 79        |
| Other Sizes than Letter, Legal, Envelopes. . . . .                         | 80        |
| Letter, Legal. . . . .   | 81        |
| Envelopes. . . . .   | 82        |
| Loading Originals. . . . .   | 83        |
| Loading Originals on the Platen Glass. . . . .                             | 84        |
| Originals You Can Load. . . . .  | 86        |
| How to Detach / Attach the Document Cover. . . . .                         | 87        |
| <b>Replacing a FINE Cartridge. . . . .</b>                                 | <b>88</b> |
| Replacing a FINE Cartridge. . . . .  | 89        |
| Checking the Ink Status. . . . .   | 94        |
| Checking the Ink Status with the Ink Lamps on the Operation Panel. . . . . | 95        |
| <b>Maintenance. . . . .</b>  | <b>96</b> |
| When Printing Becomes Faint or Colors Are Incorrect. . . . .               | 97        |
| Maintenance Procedure. . . . .   | 98        |
| Printing the Nozzle Check Pattern. . . . .                                 | 100       |
| Examining the Nozzle Check Pattern. . . . .                                | 101       |
| Cleaning the Print Head. . . . .   | 102       |
| Cleaning the Print Head Deeply. . . . .                                    | 103       |
| Aligning the Print Head. . . . .   | 104       |
| Performing Maintenance from a Computer. . . . .                            | 106       |
| Cleaning the Print Heads from Your Computer. . . . .                       | 107       |
| Cleaning the Paper Feed Rollers from Your Computer. . . . .                | 109       |
| Aligning the Print Head. . . . .   | 110       |
| Aligning the Print Head Position from Your Computer. . . . .               | 111       |
| Aligning the Print Head Position Automatically from Your Computer. . . . . | 115       |
| Use Your Computer to Print a Nozzle Check Pattern. . . . .                 | 116       |

|   |            |
|---|------------|
| Cleaning Inside the Machine. . . . .  | 117        |
| Cleaning the Machine. . . . .   | 118        |
| Cleaning the Exterior of the Machine. . . . .   | 119        |
| Cleaning the Platen Glass and Document Cover. . . . .   | 120        |
| Cleaning the Paper Feed Roller. . . . .   | 121        |
| Cleaning the Inside of the Machine (Bottom Plate Cleaning). . . . .                           | 122        |
| Cleaning the Protrusions inside the Machine. . . . .  | 124        |
| <b>Changing the Machine Settings. . . . .</b>   | <b>125</b> |
| Changing Machine Settings from Your Computer. . . . .   | 126        |
| Changing the Print Options. . . . .   | 127        |
| Registering a Frequently Used Printing Profile. . . . .                                       | 128        |
| Setting the Ink Cartridge to be Used. . . . .   | 130        |
| Managing the Machine Power. . . . .   | 131        |
| Reducing the Machine Noise. . . . .   | 133        |
| Changing the Machine Operation Mode. . . . .  | 134        |
| Changing the Machine Settings Using the Operation Panel. . . . .                              | 136        |
| About Quiet setting. . . . .  | 137        |
| Turning on/off the Machine Automatically. . . . .   | 138        |
| <b>Information about Network Connection. . . . .</b>  | <b>139</b> |
| Useful Information about Network Connection. . . . .  | 140        |
| Initial Values Set at Factory (Network). . . . .  | 141        |
| Connecting the Machine to the Computer Using a USB Cable. . . . .                             | 142        |
| When Detecting the Printers Have the Same Name during Setup. . . . .                          | 143        |
| Connecting to Other Computer with LAN/Changing the Connection Method from USB to LAN. . . . . | 144        |
| Printing Out Network Setting Information. . . . .   | 145        |
| <b>About Network Communication. . . . .</b>   | <b>147</b> |
| Changing and Confirming Network Settings. . . . .   | 148        |
| IJ Network Tool. . . . .  | 149        |
| Changing the Settings in the Wireless LAN Sheet. . . . .                                      | 150        |
| Changing the WEP Detailed Settings. . . . .   | 152        |
| Changing the WPA or WPA2 Detailed Settings. . . . .   | 154        |
| Changing the Settings in the Wired LAN Sheet. . . . .   | 157        |
| Changing the Settings in the Admin Password Sheet. . . . .                                    | 158        |
| Monitoring Wireless Network Status. . . . .   | 159        |
| Initializing the Network Settings of the Machine. . . . .                                     | 162        |
| Viewing the Modified Settings. . . . .  | 163        |
| Screens for Network Connection of IJ Network Tool. . . . .                                    | 164        |

|   |     |
|---|-----|
| Canon IJ Network Tool Screen. . . . .   | 165 |
| Configuration Screen. . . . .   | 168 |
| Wireless LAN Sheet. . . . .   | 169 |
| Search Screen. . . . .  | 171 |
| WEP Details Screen. . . . .   | 173 |
| WPA Details Screen. . . . .   | 174 |
| WPA2 Details Screen. . . . .  | 175 |
| Authentication Type Confirmation Screen. . . . .                              | 176 |
| PSK: Passphrase and Dynamic Encryption Setup Screen. . . . .                  | 177 |
| Setup Information Confirmation Screen. . . . .                                | 178 |
| Wired LAN Sheet. . . . .  | 179 |
| Admin Password Sheet. . . . .   | 180 |
| Network Information Screen. . . . .   | 181 |
| Access Control Sheet. . . . .   | 182 |
| Edit Accessible MAC Address Screen/Add Accessible MAC Address Screen. . . . . | 186 |
| Edit Accessible IP Address Screen/Add Accessible IP Address Screen. . . . .   | 187 |
| Other Screens of IJ Network Tool. . . . .                                     | 188 |
| Canon IJ Network Tool Screen. . . . .   | 189 |
| Status Screen. . . . .  | 192 |
| Connection Performance Measurement Screen. . . . .                            | 193 |
| Maintenance Screen. . . . .   | 195 |
| Network Setup of the Card Slot Screen. . . . .                                | 196 |
| Associate Port Screen. . . . .  | 198 |
| Network Information Screen. . . . .   | 199 |
| Appendix for Network Communication. . . . .                                   | 200 |
| Using the Card Slot over a Network. . . . .                                   | 201 |
| When the Printer Driver Is Not Associated with a Port. . . . .                | 203 |
| About Technical Terms. . . . .  | 204 |
| Restrictions. . . . .   | 210 |
| About Firewall. . . . .   | 211 |
| Tips for Ensuring Optimal Printing Quality. . . . .                           | 212 |
| Useful Information about Ink. . . . .   | 213 |
| Key Points to Successful Printing. . . . .                                    | 214 |
| Be Sure to Make Paper Settings after Loading Paper. . . . .                   | 215 |
| Canceling a Print Job. . . . .  | 216 |
| Key to Enjoying Consistent Printing Quality. . . . .                          | 217 |
| Precautions for Safe Transport of the Machine. . . . .                        | 218 |
| Legal Limitations on Use of Your Product and Use of Images. . . . .           | 219 |



# Read Me First

➔ [Notes on Online Manual Usage](#)

➔ [How to Print](#)

## Notes on Online Manual Usage

- Reproduction, diversion or copying of any text, photo or image published in the *Online Manual* (hereinafter referred to as "this guide"), in whole or in part, is prohibited.
- In principle, Canon shall change or delete the contents of this guide without prior notice to customers. In addition, Canon may suspend or stop the disclosure of this guide due to unavoidable reasons. Canon shall not be liable for any damage suffered by customers as a result of changes in or deletion of information in this guide, or suspension/stoppage of disclosure of this guide.
- Although the contents of this guide have been prepared with utmost care, please contact the service center if you find any incorrect or missing information.
- In principle, the descriptions in this guide are based on the product at the time of its initial sale.
- This guide does not disclose the manuals of all the products sold by Canon. See the manual supplied with the product when using a product that is not described in this guide.

## How to Print

Use the print function of your Web browser to print this guide.

To set to print background colors and images, follow the steps below.

### ➤➤ Note

- In Windows 8, print in the desktop version.

#### • In Internet Explorer 9 or 10

1. Select  (Tools) > **Print** > **Page setup...**
2. Select the **Print Background Colors and Images** checkbox.

#### • In Internet Explorer 8

1. Press the Alt key to display the menus.  
Alternatively, from **Tools**, select **Toolbars** > **Menu Bar** to display the menus.
2. Select **Page Setup...** from the **File** menu.
3. Select the **Print Background Colors and Images** checkbox.

#### • In Mozilla Firefox

1. Press the Alt key to display the menus.  
Alternatively, click **Firefox**, then select **Menu Bar** from the right arrow of **Options** to display the menus.
2. Select **Page Setup...** from the **File** menu.
3. Select the **Print Background (colors & images)** checkbox in **Format & Options**.

# How to Use the Online Manual

## Symbols Used in This Document

### **Warning**

Instructions that, if ignored, could result in death or serious personal injury caused by incorrect operation of the equipment. These must be observed for safe operation.

### **Caution**

Instructions that, if ignored, could result in personal injury or material damage caused by incorrect operation of the equipment. These must be observed for safe operation.

### **Important**

Instructions including important information. To avoid damage and injury or improper use of the product, be sure to read these indications.

### **Note**

Instructions including notes for operation and additional explanations.

### **Basic**

Instructions explaining basic operations of your product.

### **Note**

- 
- Icons may vary depending on your product.
- 

## Touch-enabled Device Users

For touch actions, you need to replace "right-click" in this document with the action set on the operating system. For example, if the action is set to "press and hold" on your operating system, replace "right-click" with "press and hold."



## Trademarks and Licenses

- Microsoft is a registered trademark of Microsoft Corporation.
- Windows is a trademark or registered trademark of Microsoft Corporation in the U.S. and/or other countries.
- Windows Vista is a trademark or registered trademark of Microsoft Corporation in the U.S. and/or other countries.
- Internet Explorer is a trademark or registered trademark of Microsoft Corporation in the U.S. and/or other countries.
- Mac, Mac OS, AirPort, Safari, Bonjour, iPad, iPhone and iPod touch are trademarks of Apple Inc., registered in the U.S. and other countries. AirPrint and the AirPrint logo are trademarks of Apple Inc.
- IOS is a trademark or registered trademark of Cisco in the U.S. and other countries and is used under license.
- Google Cloud Print, Google Chrome, Android and Google Play are either registered trademarks or trademarks of Google Inc.
- Adobe, Photoshop, Photoshop Elements, Lightroom, Adobe RGB and Adobe RGB (1998) are either registered trademarks or trademarks of Adobe Systems Incorporated in the United States and/or other countries.
- Photo Rag is a trademark of Hahnemühle FineArt GmbH.
- Bluetooth is a trademark of Bluetooth SIG, Inc., U.S.A. and licensed to Canon Inc.
- All other company names and products mentioned herein may be trademarks or registered trademarks of their respective companies.

### ►► Note

- The formal name of Windows Vista is Microsoft Windows Vista operating system.

Enter keywords in the search window and click  (Search).

You can search for target pages in this guide.

Entry example: "(your product's model name) load paper", "(your product's model name) 1000"

---

## Search Tips

You can search for target pages by entering keywords in the search window.

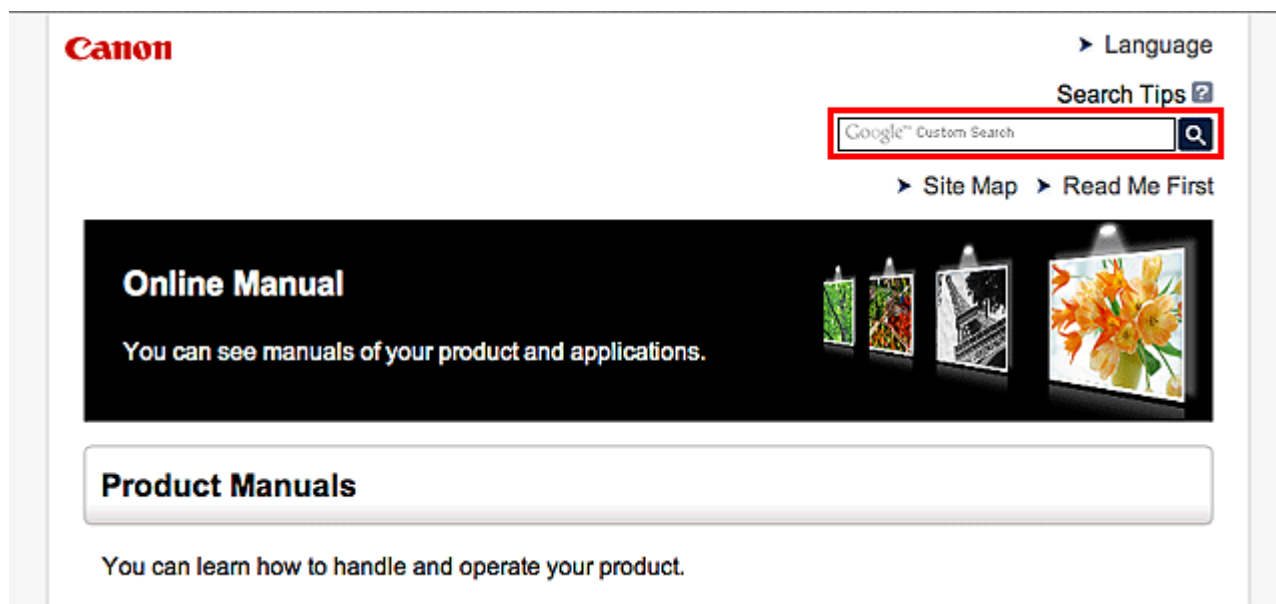

### ▶▶▶ Note

- The displayed screen may vary.

#### • Searching for Functions

You can find target pages easily by entering your product's model name and a keyword for the function you want to learn about.

Example: When you want to learn how to load paper

Enter "(your product's model name) load paper" in the search window and perform a search

#### • Troubleshooting Errors

You can obtain more accurate search results by entering your product's model name and a support code.

Example: When the following error screen appears

Enter "(your product's model name) 1000" in the search window and perform a search

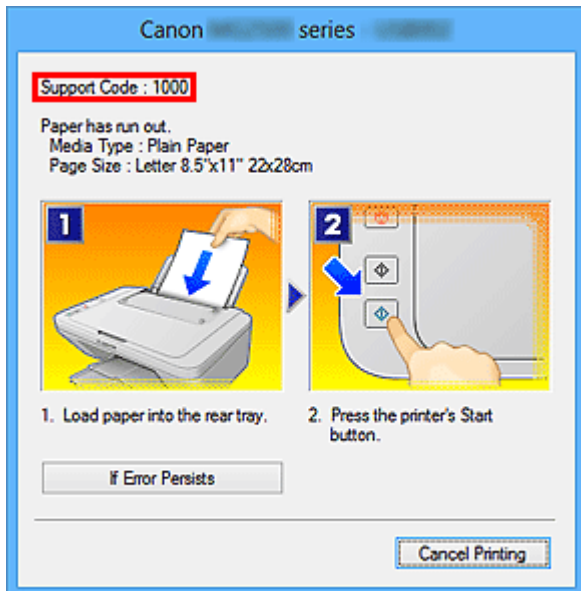

### ►►► Note

- The displayed screen varies depending on your product.

#### • **Searching for Application Functions**

You can find target pages easily by entering your application's name and a keyword for the function you want to learn about.

Example: When you want to learn how to print collages with My Image Garden  
Enter "My Image Garden collage" in the search window and perform a search

#### • **Searching for Reference Pages**

You can search for reference pages described in this guide by entering your model name and a page title.

You can find reference pages more easily by entering the function name as well.

Example: When you want to browse the page referred to by the following sentence on a scanning procedure page

Refer to "Color Settings Tab" for your model from Home of the *Online Manual* for details.

Enter "(your product's model name) scan Color Settings Tab" in the search window and perform a search

## **Window Used in Operation Explanation**

In this guide, most of the operations are described based on the windows displayed when Windows 8 operating system (called Windows 8 below) is used.

## Useful Functions Available on the Machine

The following useful functions are available on the machine.

Enjoy pleasant photography experience by utilizing various functions.

### ▶ Useful Functions Available from Applications and the Main Unit



You can create items such as collages easily or download delightful printing materials, and print them.

### ▶ Helpful Functions Available Through the Network



You can print more conveniently through integration with smartphones and other devices or with services on the web.

# Useful Functions Available from Applications and the Main Unit

On the machine, the following useful functions are available from applications and the main unit.

- [Print Photos Easily](#)
- [Download Content Materials](#)

## Print Photos Easily Using an Application

### Organize Images Easily

In My Image Garden, you can register the names of people and events to photos.

You can organize photos easily as you can display them not only by folder but also by calendar, event, and person. This also allows you to find the target photos easily when you search for them later on.

<Calendar View>



<People View>

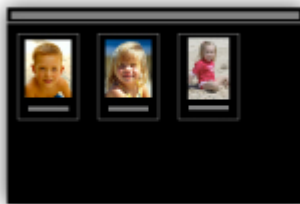

### Display Recommended Items in Slide Shows

Based on the information registered to photos, Quick Menu automatically selects the photos on your computer and creates recommended items such as collages and cards. The created items appear in slide shows.



If there is an item you like, you can easily print it in just two steps.

1. In Image Display of Quick Menu, select the item you want to print.
2. Print the item with My Image Garden.



## Place Photos Automatically

Delightful items are created easily as the selected photos are placed automatically according to the theme.



## Other Various Functions

My Image Garden has many other useful functions.

Refer to "What You Can Do with My Image Garden" for details.

## Download a Variety of Content Materials

### CREATIVE PARK

A "printing materials site" where you can download all the printing materials for free.

Various types of content such as seasonal cards and paper crafts that can be made by assembling paper parts are provided.

It is easily accessible from Quick Menu.

### CREATIVE PARK PREMIUM

A service where customers using models that support PREMIUM Contents can download exclusive printing materials.

PREMIUM Contents can be downloaded easily via My Image Garden. Downloaded PREMIUM Contents can be printed directly with My Image Garden.

To download PREMIUM Contents, make sure that genuine Canon ink tanks/ink cartridges are installed for all colors on a supported printer.



►► Note

- The designs of PREMIUM Contents provided in this page are subject to change without prior notice.



## Helpful Functions Available Through the Network

The following useful functions are available on the machine.

Enjoy even more pleasant photography experience by utilizing various functions.

### ▶▶▶ Important

- Some functions may not be available in certain countries or regions.

- ➔ [Use App from Various Environments by Using PIXMA Cloud Link](#)
- ➔ [Upload scanned images to the web](#)
- ➔ [Print web data easily](#)
- ➔ [Print by using Google Cloud Print](#)
- ➔ [Print directly from your iPad, iPhone, or iPod touch](#)
- ➔ [Use the Canon printing plugin](#)
- ➔ [Printing via Mopria](#)
- ➔ [Manage Your Printer from a Remote Location by Using Remote UI](#)
- ➔ [Print Easily by Sending E-mail from Your Computer or Smartphone](#)
- ➔ [Print easily from your smartphone by using PIXMA Printing Solutions](#)
- ➔ [Printing with Windows RT](#)

### Use App from Various Environments by Using PIXMA Cloud Link

By using PIXMA Cloud Link, you can access an application that supports this service and use it directly without using your computer. In addition to printing photos and documents from various applications, you can register and manage applications.

Refer to "Use PIXMA Cloud Link" for details.

### Upload Scanned Images Easily to the Web

If you use Evernote or Dropbox on your computer, you can easily upload scanned images to the web. Uploaded images can be utilized from other computers, smartphones, etc.

Refer to "[Online Storage Integration Function](#)" for details.



### Print Photos on Photo-Sharing Services or Print Web Template Forms Easily from the Machine

You can directly print photos on photo-sharing services or template forms offered on the web without using a computer.

- **Online Album Photo Print**

You can access photo-sharing services on the web from the machine and directly print photos in online albums (such as Picasa Web Albums) while checking them on the printer screen.

- **Web Template Form Print**

Canon offers various template forms including seasonal stationery and calendars on the web. You can download and print the template forms you want anytime, as much as you need, by operating the machine only.



## **Print in Various Environments with Google Cloud Print**

The machine is compatible with Google Cloud Print (Google Cloud Print is a service provided by Google Inc.).

By using Google Cloud Print, you can print from anywhere with applications or services supporting Google Cloud Print.

Refer to "[Printing with Google Cloud Print](#)" for details.

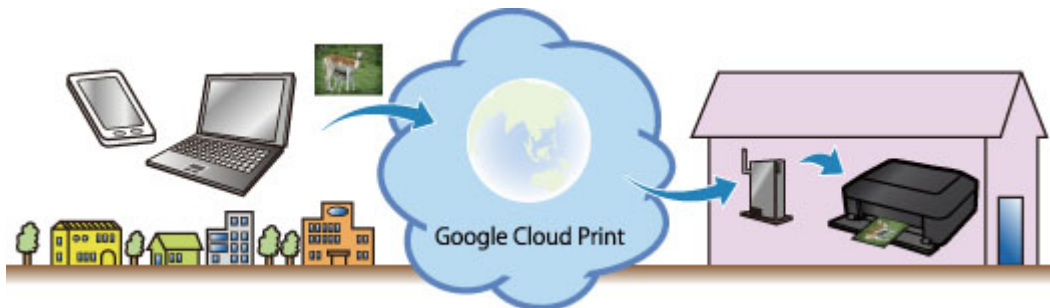

## **Print Directly from iPad, iPhone, or iPod touch with Apple AirPrint**

The machine is compatible with the AirPrint function of Apple iOS devices.

You can directly print e-mails, photos, web pages, etc. from iPad, iPhone, or iPod touch to the machine over wireless LAN.

Refer to "[Printing from AirPrint Compliant Device](#)" for details.



## Use the Canon printing plugin

Canon Print Service is a printing plug-in for Android 4.4 available for free on Google Play. Installing and activating the plug-in enables your Android smartphone or tablet to print wirelessly to a Canon printer.

## Printing via Mopria

You can print wirelessly to a Canon printer from a Mopria compatible Android smartphone or tablet. See the Mopria homepage (<http://www.mopria.org>) for details including supported devices.

## Manage Your Printer from a Remote Location by Using Remote UI

By using **Remote UI**, you can set up this machine, check the machine status, and even perform maintenance from your computer or smartphone.

Because you can use this service from a remote location through the network, you can check printer information even when you're out away from the printer.

Refer to "[Using Remote UI](#)" for details.

## Print Easily by Sending E-mail from Your Computer or Smartphone

By using **Print from E-mail**, you can easily print a photo or document saved on your computer or smartphone just by attaching it to an e-mail.

You can easily print from your travel destination or an outside location. You can even let friends and family print on the printer by setting up your printer beforehand.

Refer to "[How to Use Print from E-mail](#)" for details.



## Print Easily from a Smartphone with PIXMA Printing Solutions

Use PIXMA Printing Solutions to easily print photos saved on a smartphone wirelessly.

You can also receive scanned data (PDF or JPEG) directly on a smartphone without using a computer.

PIXMA Printing Solutions can be downloaded from App Store and Google Play.



## **Printing with Windows RT**

When you use Windows RT, printing is easy because you simply connect this machine to the network.

For information about connecting to the network, see [here](#).

When the connection is complete, the Canon Inkjet Print Utility software, which allows you to specify detailed print settings, is downloaded automatically.

By using Canon Inkjet Print Utility, you can check the printer status and specify detailed print settings. (The available functions will differ depending on your usage environment and connection method.)

## Online Storage Integration Function

The machine can integrate with online storage services such as Evernote.



### Integration with Online Notetaking Service "Evernote"

If an Evernote client application is installed on your computer, you can import scanned images into the application and upload them to the Evernote server.

The uploaded images can be browsed from other computers, smartphones, etc.

To use Evernote, you need to create an account. See the "CREATE ACCOUNT" page of Evernote for account creation.

- **Settings**

In the Settings Dialog Box of IJ Scan Utility, select the item you want to set, then select Evernote for **Send to an application** in **Application Settings**.

Refer to "Settings Dialog Box" for your model from Home of the *Online Manual* for details.

### **»» Important**

- The Evernote service features are subject to change or termination without prior notice.

# Printing with Google Cloud Print

The machine is compatible with Google Cloud Print™ (Google Cloud Print is a service provided by Google Inc.).

By using Google Cloud Print, you can print from anywhere with applications or services supporting Google Cloud Print.

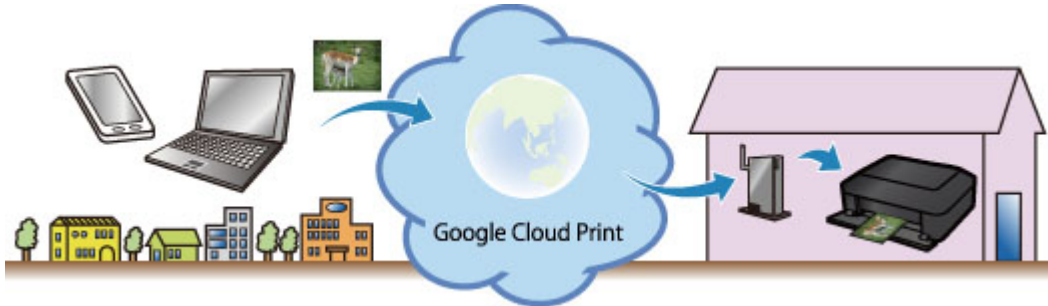

1. [Preparations for Printing with Google Cloud Print](#)
2. [Printing from Computer or Smartphone with Google Cloud Print](#)

## ▶▶▶ Important

- LAN connection with the machine and Internet connection are required to register the machine and to print with Google Cloud Print. Internet connection fees apply.
- This function may not be available depending on the country or region you live in.

# Preparations for Printing with Google Cloud Print

To print with Google Cloud Print, you need to get Google account and register the machine with Google Cloud Print in advance.

➔ [Getting Google Account](#)

If you already have Google account, register the machine.

➔ [Registering the Machine with Google Cloud Print](#)

## Getting Google Account

First, get your Google account in order to register the machine with Google Cloud Print.

Access to Google Cloud Print with the web browser on the computer or the mobile device, then register the required information.

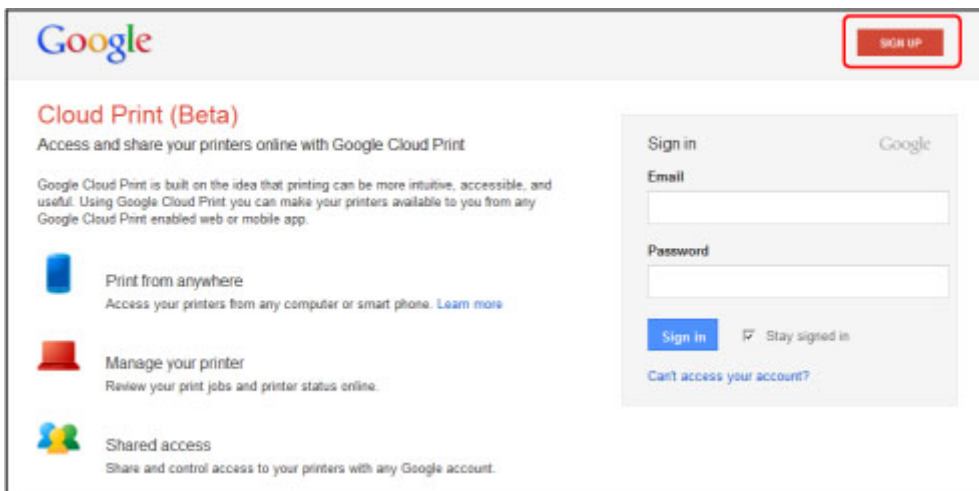

\* The screen above may change without prior notice.

## Registering the Machine with Google Cloud Print

Register the machine with Google Cloud Print.

The authentication procedure using the web browser on the computer or the mobile device is required in the process of registering. Because the authentication URL is printed from machine when the authentication process is performed, prepare A4 or Letter-sized plain paper.

### ➤➤➤ Important

- LAN connection with the machine and Internet connection are required to register the machine and to print with Google Cloud Print. Internet connection fees apply.
- If the machine's owner changes, [delete the machine from Google Cloud Print](#).

1. Make sure that the machine is turned on

### If your printer has a LCD monitor

2. From the Home screen, select **Setup** (or press the **Setup** button on the operation panel)

3. Select **Web service setup -> Connection setup -> Google Cloud Print setup (GoogleCloudPrint) -> Register with Google Cloud Print (Register w/ service)**

**▶▶▶ Note**

- If you have already registered the machine with Google Cloud Print, the confirmation message to re-register the machine is displayed.

4. When the confirmation screen to register the machine is displayed, select **Yes**

5. Select a display language on the print setting screen of Google Cloud Print

The confirmation message to print the authentication URL is displayed.

6. Load A4 or Letter-sized plain paper, then select OK

The authentication URL is printed.

7. Ensure that the authentication URL is printed, select **Yes**

8. Perform the authentication process using the web browser on the computer or the mobile device

Access to the URL using the web browser on the computer or the mobile device and perform the authentication process following the on-screen instructions.

**▶▶▶ Note**

- Perform the authentication process with your Google account which you have gotten in advance.

9. When the message that the registration is complete is displayed on the LCD of the machine, select OK

When authentication process is complete properly, the registration items are displayed. When authentication process is complete, [you can print the data with Google Cloud Print](#).

When authentication process is not complete properly and the error message is displayed, select OK. When the confirmation message to print the authentication URL is displayed, print the authentication URL, then perform the authentication process on the computer again.

## **If your printer does not have a LCD monitor**

2. Remote UI startup

3. Select **Google Cloud Print setup -> Register with Google Cloud Print**

**▶▶▶ Note**

- If you have already registered the machine with Google Cloud Print, the confirmation message to re-register the machine is displayed.

4. When the confirmation screen to register the machine is displayed, select **Yes**



5. In the print setup for Google Cloud Print, select the display language, and then select **Authentication**
6. When the registration completion message appears, select OK

## Deleting the Machine from Google Cloud Print

If the machine's owner changes or if you want to re-register the machine, delete the machine from Google Cloud Print by following the steps below.

1. Make sure that the machine is turned on

### If your printer has a LCD monitor

2. From the Home screen, select **Setup** (or press the **Setup** button on the operation panel)
3. Select **Web service setup** -> **Connection setup** -> **Google Cloud Print setup (GoogleCloudPrint)** -> **Delete from Google Cloud Print (Delete from service)**
4. When the confirmation screen to delete the machine is displayed, select **Yes**

### If your printer does not have a LCD monitor

2. Remote UI startup
3. Select **Google Cloud Print setup** -> **Delete from Google Cloud Print**
4. When the confirmation screen to delete the machine is displayed, select **Yes**

# Printing from Computer or Smartphone with Google Cloud Print

When you send print data with Google Cloud Print, the machine receives the print data and prints it automatically if the machine is turned on.

When printing from a computer, smartphone, or other external device with Google Cloud Print, load paper into the machine in advance.

## Sending the Print Data with Google Cloud Print

1. Make sure that the machine is turned on

### ▶▶▶ Note

- If you want to send the print data from an outside location, turn on the machine in advance.

2. Print from the computer or smartphone

The figure below is an example of when printing from the web browser corresponding with Google Cloud Print. The screen differs depending on the applications or services supporting Google Cloud Print.

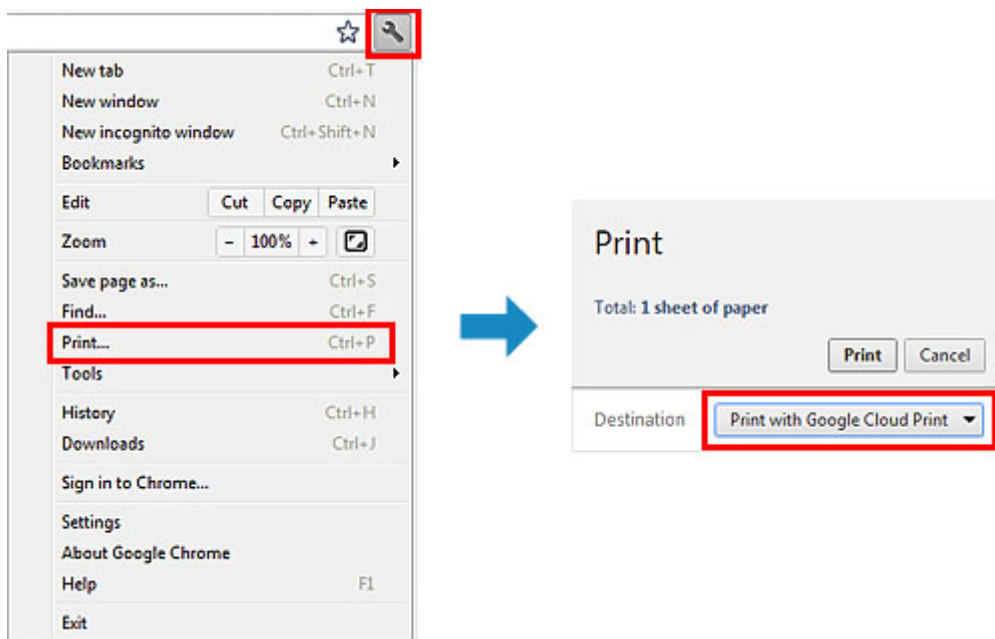

When the preparation for printing with Google Cloud Print is complete and when the machine is turned on, the machine receives the print data and prints it automatically.

### ▶▶▶ Note

- Depending on the communication status, it may take a while to print the print data or the machine may not receive the print data.
- While printing with Google Cloud Print, the printing may be canceled depending on the machine's status, such as when the machine is being operated or an error has occurred. To resume printing, check the machine's status, then print with Google Cloud Print again.
- For print settings:
  - If you select the media type other than plain paper or if you select the paper size other than A4/Letter/B5/A5-size, the print data is printed in single-sided even when you select the duplex print setting. (\* The paper size differs depending on the model of your printer. For information about

the supported paper sizes, go to the *Online Manual* home page, and refer to the "Cannot Print Properly with Automatic Duplex Printing" for your model.)

- If you select plain paper as media type or if you select B5/A5-size as paper size, the print data is printed with border even when you select the borderless print setting.
- The print results may differ from the print image depending on the print data.
- Depending on the device sending the print data, you may not select the print settings when sending the print data with Google Cloud Print.

## When you want to print from Google Cloud Print immediately

When the machine cannot receive the print data, or you want to start printing immediately, you can check whether there is a print job on the Google Cloud Print and start printing manually.

Follow the steps below.

### ▶▶▶ Important

- This function is not available depending on the printer you are using. To confirm whether this function is available with your printer, refer to [List of Function for Each Model](#) (Google Cloud Print).

1. Make sure that the machine is turned on
2. From the Home screen, select **Setup** (or press the **Setup** button on the operation panel)
3. Select **Web service inquiry**

### ▶▶▶ Note

- If you have not registered the machine with Google Cloud Print, **Web service inquiry** is not displayed.  
[Register the machine with Google Cloud Print.](#)

## If your LCD monitor is a color model

4. Select **Print from Google Cloud Print**

The confirmation screen to check is displayed.

5. Select **Yes**

If there is the print data, the machine receives the print data and prints it.

## If your LCD monitor is a monochrome model

4. Select **GoogleCloudPrint**

5. Press the **OK** button

Connect to the server. If print data is available, print that data.

# Using Remote UI

This service allows you to check printer information and execute utility functions from your computer or smartphone.

You can also use the convenient web services presented by Canon.

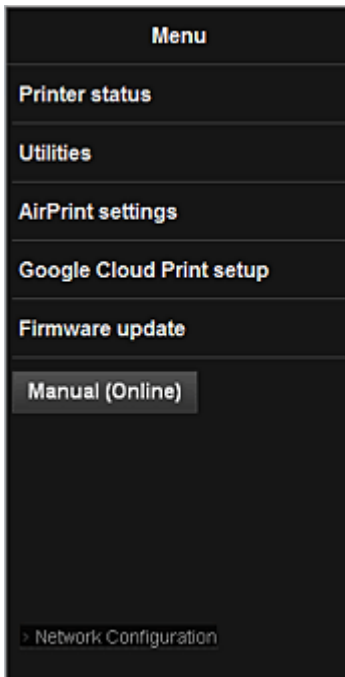

## Checking the printer IP address



To use this service, first check the IP address of this machine from the operation panel of the machine.

### »» Important

- Before you check the IP address of this machine or use the **Remote UI**, make sure that the machine is connected to the LAN and the LAN environment is connected to the Internet. Note that the customer is responsible for paying all Internet connection fees.

1. Check that the machine has been turned on

### If your printer has a LCD monitor

2. From the home window, select  **Setup** ->  **Device settings** -> **LAN settings** -> **Confirm LAN settings** -> **WLAN setting list** or **LAN setting list**. Then from the displayed window, check the IP address.

#### »» Note

- To print the IP address, load one sheet of A4 size or Letter size plain paper. Then from the

home window, select  **Setup** ->  **Device settings** -> **LAN settings** -> **Confirm LAN settings** -> **Print LAN details**, in sequence.

## If your printer does not have a LCD monitor

2. Load one sheet of A4 size or Letter size plain paper
3. Hold down the **Stop** button until the **Alarm** lamp flashes 15 times
4. Release the button

Printing of the network setup information starts.

## Remote UI startup

In the Web browser, directly enter the IPv4 address that you checked from the LCD monitor of the machine. The **Remote UI** starts.

1. From your computer, smartphone, or tablet device, open the Web browser, and enter the following URL:

http:// <Printer IP address>

For "<Printer IP address>" enter the IP address that you checked in "Checking the printer IP address."

2. Entering **Username** and Administrator's Password

From the authentication screen, enter the **Username** and **Password**.

**Username:** ADMIN

**Password:** See "About the Administrator Password."

### **Note**

- The **Username** display may differ depending on your browser.

3. **Remote UI** startup

The **Remote UI** starts and the top window is displayed.

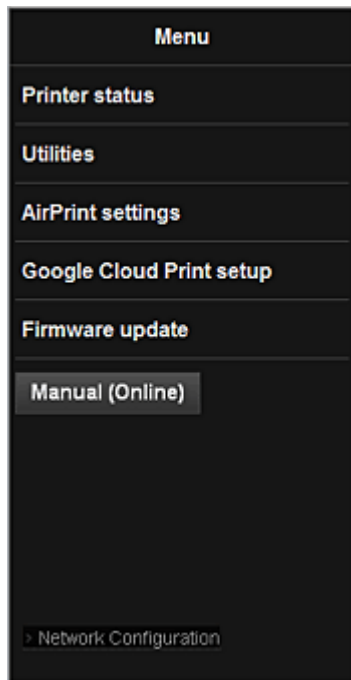

### **Printer status**

This function displays printer information such as the remaining ink amount, the status, and detailed error information.

You can also connect to the ink purchase site or support page, and use Web Services.

### **Utilities**

This function allows you to set and execute the machine utility functions such as cleaning.

### **AirPrint settings**

This function allows you to specify the Apple AirPrint settings, such as position information.

### **Google Cloud Print setup**

This function allows you to register this machine to Google Cloud Print or delete the machine.

### **Firmware update**

This function allows you to update the firmware and check version information.

### **Manual (Online)**

This function displays the *Online Manual*.

### **Network Configuration**

This function displays the network settings.

## Printing from AirPrint Compliant Device

This document explains how to use AirPrint to print wirelessly from your iPad, iPhone and iPod touch to a Canon printer. AirPrint enables you to print photos, email, Web pages and documents from your Apple device directly to your printer without installing a driver.



### Checking Your Environment

First, check your environment.

- AirPrint Operation Environment

To use AirPrint, you will need one of the following Apple devices running the latest version of iOS: iPad (all models), iPhone (3GS or later), or iPod touch (3rd generation or later).

- Network Environment

The Apple device (iPad, iPhone, or iPod touch) and this machine must be connected to the same Wi-Fi network.

### Printing with AirPrint

1. Check that this machine is turned on and is connected to the LAN.
2. From the application software of your Apple device, tap the operation icon to display the menu options.

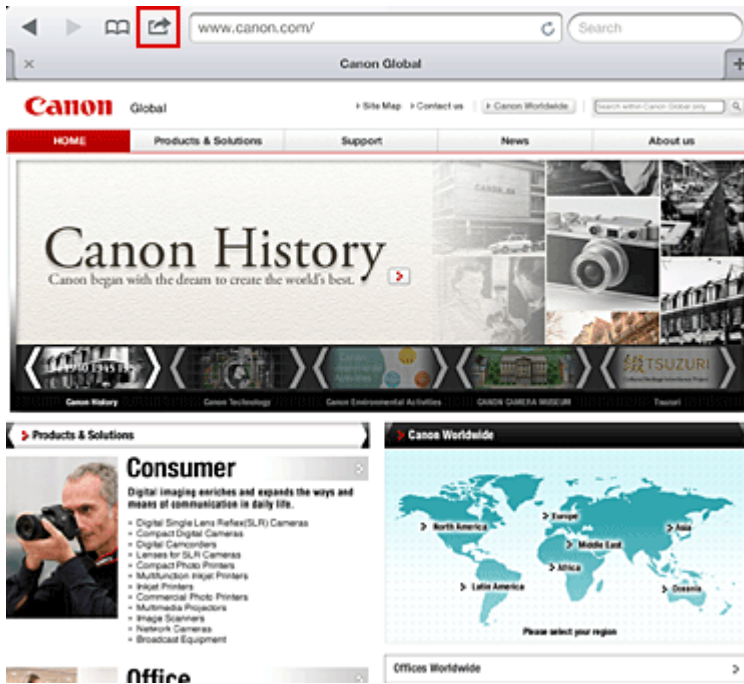

3. From the menu options, tap **Print**.



4. From **Printer Options**, select the model that you are using.

### Important

- Because some application software does not support AirPrint, **Printer Options** may not be displayed. If an application software does not let you use printer options, you cannot print from that application software.

### Note

- The printer options differ depending on the application software and model you are using. Normally, when you tap **Print** and select a model name, the displayed printer options will include up to the following four options:
  - Printer: Select a model that can be used in your wireless LAN.
  - Copies: Select the number of print copies.



- Duplex Printing: If the model supports duplex printing, you can select **On** or **Off**.
- Range: The page range can be used only with specific application software and file types (such as PDF files).

5. For **1 Copy**, click **+** or **-** to set the number of required copies.

6. For **Duplex Printing**, click **On** to enable duplex printing or click **Off** to disable the function.

7. When printing a file type that has multiple pages, such as a PDF file, click **Range** and then click **All Pages** or select the range of pages to be printed.

8. Tap the **Print**.

When you execute printing, the printer prints according to the specified settings.

## Paper Size

With AirPrint, the paper size is selected automatically according to the application software being used on the Apple device and the region in which AirPrint is used.

When Apple's photo application software is used, the default paper size is L size in Japan, and 4"x6" or KG in other countries and regions.

When documents are printed from Apple's Safari application software, the default paper size is letter size in the U.S. region, and A4 in Japan and Europe.

## »» Important

- Your application software may support different paper sizes.

## Checking the Print Status

During printing, a **Print** icon is displayed in the list of recently used application software, and you can use it to check the print progress.

To display the list of latest used application software, press the **Home** button on the Apple device twice. The **Print** icon is displayed at the bottom of the **Home** screen.



## Deleting a Print Job

To delete a print job with AirPrint, use one of the following two methods:

- From the machine: Use the operation panel of the machine to cancel the print job.
- From an Apple device: Press the **Home** button on the Apple device twice. Tap the **Print** icon and display the print job list. Tap the print job to be canceled, and then tap **Cancel Print**.

## AirPrint Troubleshooting

If the document does not print, check the following:

1. Check that the machine power is on. If the machine power is on, turn it off and then back on again, and check whether the issue is resolved.
2. Check that the machine is connected by LAN to the same network subnet as the device on which iOS is installed.
3. Check that the machine has enough paper and ink.
4. Check that no error message is displayed on the machine operation panel.

If the problem persists, use the printer driver on your computer to execute printing and check whether the document can be printed normally on the machine.

If the document cannot be printed, refer to the *Online Manual* for your model.

### ▶▶▶ Note

- After you turn on the machine, it may take few minutes before the machine can communicate through a wireless LAN connection. Confirm that the machine is connected to the wireless LAN, and then try printing.
- If Bonjour on the machine is disabled, AirPrint cannot be used. Check the LAN settings on the machine, and enable Bonjour.

### ▶▶▶ Note

- The windows used in the explanations may differ from those displayed by your Apple product or application software.

# How to Use Print from E-mail

**Print from E-mail** allows you to print attachment files easily. You only attach a picture or a document from your computer or smartphone and send the e-mail with the attached file.

You can print simply from outside like a travel destination. Also, your family or friends can print by registering beforehand.

You can use **Print from E-mail** on any Canon printer that supports the service.

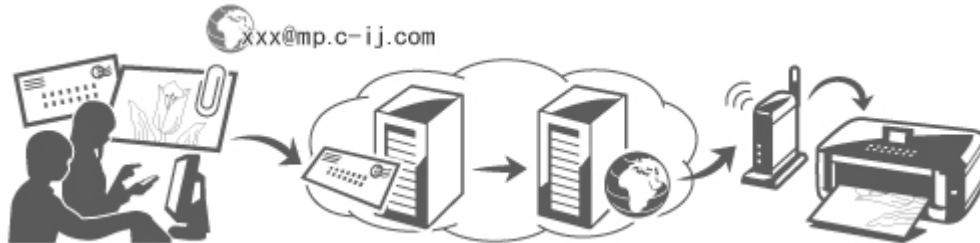

## Checking Your Environment

First, check your environment.

- **Network environment**

This product needs to be connected to a LAN with an Internet connection.

### »» Important

- The user will bear the cost of Internet access.
- This function may not be available in some countries/regions.
- This function is not available depending on the printer you are using. To confirm whether this function is available with your printer, refer to [List of Function for Each Model \(Print from E-mail\)](#).

- **Printer software (firmware) version**

If the printer's firmware version is earlier than Ver. 2.000, you need to update the firmware.

You can execute firmware update from **Remote UI** or from your printer.

To execute the update from **Remote UI**, refer to the [Remote UI usage instructions](#).

To execute the update from your printer, go to the *Online Manual* home page, and refer to the "Firmware Update" document for your printer model.

## Preparing to use Print from E-mail

To use **Print from E-mail**, you need to register the printer by entering information about the printer's owner.



1. Print the printer registration page's URL and the PIN code
2. Access the URL and enter the owner's e-mail address and other required information
3. Check if an e-mail has been sent to the e-mail address you entered
4. Access the URL provided in the e-mail and complete the printer registration process

### ►► Note

- The e-mail address that appears on the screen when you have finished registering is the e-mail address that will be used just for the **Print from E-mail** function.

➔ [For details about the registration procedure, see here](#)

## Printing from Your Computer or Smartphone

1. Prepare a file that you want to print

The file format, number of files, and file size that this printing function supports are provided below.

Supported File Formats

- Adobe PDF files
- JPEG files

### ►► Important

- Only files that are attached to e-mail can be printed. E-mail messages cannot be printed.
- Encrypted Adobe PDF files, password-protected files, and files that are set to print disabled cannot be printed.
- Files that are attached as compressed files cannot be printed.
- Files other than Adobe PDF files and JPEG files cannot be printed.

Supported Number of Files and File Sizes



- Up to 10 attachment files can be printed.
- The maximum size of an e-mail with attachment files is 5 MB.

### ►► Note

- The size of an e-mail is determined based on the size of the entire transmission file, including the e-mail message and the header.  
Therefore sometimes an attachment file cannot be printed even if the size of the attachment file is less than 5 MB.
- If the size of an attached JPEG file is less than 10 KB, the file cannot be printed.

2. Attach a file that you want to print from your PC or smartphone to the e-mail and send it to the e-mail address for printing

To check the printer address, perform one of the following operations from the operation panel of this machine:

- From the operation panel of this machine, display the home window and select  **Setup** ->  **Web service setup** -> **Web service connection setup** -> **Print from E-mail setup** -> **Check address for printing.**

- From the operation panel of this machine, select  **Web service** ->  **Web service setup** -> **Cloud settings** -> **Print from E-mail setup** -> **Check address for printing.**

### »» Important

- You will not be able to use the service during periods when the service is undergoing maintenance.

## Use the Service With More Than One Person

To allow multiple users to use this function, register users (other than the printer's owner) as members.

1. The printer's owner uses his/her PC or smartphone to access the service's login URL (<https://pr.mp.c-ij.com/po>) and logs in
2. Select the printer name that you want to add the member. Click **Member Settings** -> **Add** to enter the member's e-mail address, and click **Register**  
A URL of the member registration page is sent to the e-mail address of the newly registered member.

3. Registered member accesses to the URL that is included in the e-mail, and complete the registration

You can use this service from registered e-mail address.

### »» Note

- You can register up to 500 members.

## Print from E-mail Troubleshooting

- ➔ [The Document Does Not Print](#)
- ➔ [If You Cannot Register to the Service or Delete the Service](#)
- ➔ [If You Cannot Print after the Printer Is Repaired](#)

## The Document Does Not Print

If the document does not print, check the following:



- Check that the printer power is on.  
If the printer power is on, turn it off and then back on again, and check whether the issue is resolved.
- Check that the printer is connected to the network.
- Check that the printer is connected to a LAN and the LAN has an Internet connection.
- Look at the printer LCD monitor and check that no error message is displayed.  
If the problem persists, use the printer driver on your computer to execute printing and check whether



the document can be printed normally on the printer.

If the document cannot be printed, refer to the on-screen manual (operating instructions) that comes with the printer.

- Check that the file attached to the e-mail is a Adobe PDF file or an JPEG file.
- Check whether the e-mail address of the send destination is correct.

To check the printer address, perform one of the following operations from the operation panel of this machine:

- From the operation panel of this machine, display the home window and select  **Setup** ->  **Web service setup** -> **Web service connection setup** -> **Print from E-mail setup** -> **Check address for printing**.

- From the operation panel of this machine, select  **Web service** ->  **Web service setup** -> **Cloud settings** -> **Print from E-mail setup** -> **Check address for printing**.
- Check that the user's e-mail address for using this service is registered.  
If you want to check the error details, the printer owner have to access the login URL (<https://pr.mp.c-ij.com/po>).
- In the **Print Status** screen, click **Go to Print History Screen** and check the history of jobs that were sent. You can check the error details.  
If you want to check the error details, the printer owner have to access the login URL (<https://pr.mp.c-ij.com/po>).

### ▶▶▶ Note

- For a wireless LAN connection, after the printer is turned on, it may take a few minutes before communication becomes possible. Confirm that your printer is connected to the wireless LAN, and then try printing.

## If You Cannot Register to the Service or Delete the Service

### If You Cannot Register to the Service

- If the printer operation panel display the message "Failed to register with "Print from E-mail".", the registration to **Print from E-mail** may not have been completed in time. Select **OK** to release the error, and start over again from the beginning.
- Check that the firmware version of the printer has been updated.





### If You Do Not Receive the URL to Complete the Registration by E-mail

- An incorrect e-mail address may have been entered. Wait about 30 minutes, and operate the printer operation panel to print the printer registration URL and PIN code. Then re-register from the beginning.

### If You Cannot Delete the Service

- If the printer operation panel display the message "Failed to connect to "Print from E-mail". Only the information on the printer was deleted." is displayed, it could be that the registration information on the service could not be deleted even though the **Print from E-mail** information stored on this machine was deleted.  
Select **OK** to release the error, and then access the service's login URL (<https://pr.mp.c-ij.com/po>) to delete the registration information.

- If the **Print from E-mail** information stored on this printer could not be deleted even though the registration information on the service was deleted, delete the registration information from **Deregistration of Registered Printer(s)** by performing one of the following operations:

- From the operation panel of this machine, display the home window and select  **Setup** ->  **Web service setup** -> **Web service connection setup** -> **Print from E-mail setup** -> **Deregistration of Registered Printer(s)**.
- From the operation panel of this machine, select  **Web service** ->  **Web service setup** -> **Cloud settings** -> **Print from E-mail setup** -> **Deregistration of Registered Printer(s)**.

## If You Cannot Print after the Printer Is Repaired

Re-registering the printer and the printer owner

- When the printer is repaired, all of the registered information is deleted and **Print from E-mail** can no longer be used.  
If you want to use this service again, you must re-register the printer and the printer owner.  
For information about the re-registration procedure, see "[Preparing to Use Print from E-mail](#)".  
Even if users other than the owner were registered as members, repeat the registration starting from [here](#).

## Trademarks

- Windows is a trademark or registered trademark of Microsoft Corporation in the U.S. and/or other countries.
- Windows Vista is a trademark or registered trademark of Microsoft Corporation in the U.S. and/or other countries.
- Mac OS, Bonjour, iPad, iPhone, iPod touch, and Safari are trademarks of Apple Inc., registered in the U.S. and other countries. AirPrint and the AirPrint logo are trademarks of Apple Inc.
- IOS is a trademark or registered trademark of Cisco in the U.S. and other countries and is used under license.
- All other company names and products mentioned herein may be trademarks or registered trademarks of their respective companies.

## Preparing to Use Print from E-mail

To use this service to print a photo or document, you need to follow the procedure provided below and register the machine.

### Print the Printer Registration Page's URL and the PIN Code

First, print the printer registration page's URL and the PIN code.

Check that there is sufficient amount of ink in the machine, and then print using the machine's operation panel.

1. Check that the machine is connected to the network

#### Important

- This product needs to be connected to a LAN with an Internet connection.

2. From the operation panel of this machine, display the home page and select **Register printer** by performing one of the following operations:

- From the operation panel of this machine, display the home window and select  **Setup** ->



**Web service setup** -> **Web service connection setup** -> **Print from E-mail setup** -> **Register printer**.

- From the operation panel of this machine, display the home window and select  **Web**



**service** -> **Web service setup** -> **Cloud settings** -> **Print from E-mail setup** -> **Register printer**.

3. Follow the instructions on the screen and print the printer registration URL and PIN code

#### Important

- Do not turn off the power on the machine until the registration process is completed. Access the printed URL and log in within 25 minutes.
- If you canceled the registration before it is completed, repeat the procedure from printing the registration information.

### Access the Printed URL and Enter the Owner's E-mail Address and Other Required Information

Next, enter the owner's e-mail address and other required information.

1. Access the printed URL using the PC's web browser, and click **Log In**
2. In the use agreement window, select **Agree**



**Important**

- If you do not select **Agree** in the use agreement window, you will not be able to register as the printer owner.

3. Enter the printer owner's e-mail address, and click **Next**

**Important**

- An e-mail is sent with the required information for completing the registration to the e-mail address entered for the printer's owner.
- If domain-specific reception is set, change the setting so that mail can be received from "info@mp.c-ij.com"

**Note**

- The e-mail address of the printer owner cannot be changed once the printer owner is registered. To change the e-mail address, delete the registration of the registered printer, and re-register the printer owner by using the new e-mail address. In this case, all previously registered information will be deleted.
- The notification is sent automatically to the registered e-mail address when the printing or service maintenance starts.

4. In the **Printer Owner Registration** window, enter the information shown below, and click **Next**

**User Name**

Enter any name.

The name that you enter is displayed at login.

**Important**

- The maximum number of characters that can be entered is 30.

**Language**

Select the language that you are using.

The language that you select is used in notification e-mails such as print start notices.

**Time Zone**

Refer to [this section](#), and select the standard time of the city that is nearest to the region where you live.

**Date/Time Display Format**

Select the format of your choice. The format that you select is applied to the date/time information in the screens and notification e-mails of this service.

**Daylight Saving Time**

This setting is combined with the **Time Zone** setting, and applied to the date/time information in the screens and notification e-mails of this service.

When you select **ON**, 1 hour is added to the **Time Zone** setting when the date/time information is displayed.

5. In the **Printer Registration** window, enter the **Printer Name**, and click **Confirm**

Enter any name that will allow you to identify the printer.

**»»» Important**

- The maximum number of characters that can be entered is 30.

6. In the **Confirm Owner Registration** window, check the registration information, and then click **Register**

A temporary password will be displayed.

**»»» Important**

- The temporary password that appears is not included in the notification e-mail. Be sure to write down the temporary password before closing the screen.

## Check if an E-mail Has Been Sent to the E-mail Address You Entered

A URL is notified to complete the registration to the e-mail address that for the registered printer's owner.

## Access the URL in the E-mail and Complete the Printer Registration

1. Access the URL provided in the e-mail

**»»» Important**

- You have to complete the registration within 30 minutes.

2. Enter the registered e-mail address of the printer's owner, the temporary password, and click **Log In**

3. Set a password of your choice, and click **Register**

When the password setting process is completed, the printer's e-mail address and the service's URL are displayed, and the printer's registration process is completed.

**»»» Important**

- When you enter the password, the following character restrictions apply.
  - Set a password that has 8 or more characters.
  - The characters that you can use are single-byte uppercase letters, single-byte lowercase letters, and single-byte numbers.
  - In the password, combine all of the different types of characters that can be used.
- The displayed printer's e-mail address and the URL of the login page are not sent. Be sure to write down the printer's e-mail address and the URL of the login page before closing the screen.

## Timezone List

|                    |   |
|--------------------|---|
| <b>(UTC-12:00)</b> | International Date Line West  |
| <b>(UTC-11:00)</b> | Midway Island   |
| <b>(UTC-10:00)</b> | Hawaii  |
| <b>(UTC-09:00)</b> | Alaska  |
| <b>(UTC-08:00)</b> | Tijuana, Baja California, Pacific Time (US & Canada)  |
| <b>(UTC-07:00)</b> | Arizona, Chihuahua, La Paz, Mazatlan, Mountain Time (US & Canada)   |
| <b>(UTC-06:00)</b> | Guadalajara, Mexico City, Monterrey, Saskatchewan, Central America, Central Time (US & Canada)  |
| <b>(UTC-05:00)</b> | Indiana (East), Bogota, Lima, Quito, Eastern Time (US & Canada), Caracas  |
| <b>(UTC-04:00)</b> | Asuncion, Santiago, Georgetown, La Paz, San Juan, Manaus, Atlantic Time (Canada), Newfoundland  |
| <b>(UTC-03:00)</b> | Cayenne, Greenland, Buenos Aires, Brasilia, Montevideo  |
| <b>(UTC-02:00)</b> | Mid-Atlantic  |
| <b>(UTC-01:00)</b> | Azores, Cape Verde Is.  |
| <b>(UTC+00:00)</b> | Casablanca, Dublin, Edinburgh, Lisbon, London, Monrovia, Reykjavik, Coordinated Universal Time  |
| <b>(UTC+01:00)</b> | Amsterdam, Berlin, Bern, Rome, Stockholm, Vienna, Sarajevo, Skopje, Warsaw, Zagreb, Brussels, Copenhagen, Madrid, Paris, Belgrade, Bratislava, Budapest, Ljubljana, Prague, West Central Africa |
| <b>(UTC+02:00)</b> | Athens, Bucharest, Istanbul, Amman, Windhoek, Jerusalem, Cairo, Harare, Pretoria, Beirut, Helsinki, Kyiv, Riga, Sofia, Tallinn, Vilnius, Minsk  |
| <b>(UTC+03:00)</b> | Kuwait, Riyadh, Tbilisi, Nairobi, Baghdad, Moscow, St. Petersburg, Volgograd, Tehran  |
| <b>(UTC+04:00)</b> | Abu Dhabi, Muscat, Yerevan, Baku, Port Louis, Kabul   |
| <b>(UTC+05:00)</b> | Islamabad, Karachi, Ekaterinburg, Tashkent, Sri Jayawardenepura, Chennai, Kolkata, Mumbai, New Delhi, Kathmandu   |
| <b>(UTC+06:00)</b> | Astana, Dhaka, Almaty, Novosibirsk, Yangon (Rangoon)  |
| <b>(UTC+07:00)</b> | Krasnoyarsk, Bangkok, Hanoi, Jakarta  |
| <b>(UTC+08:00)</b> | Irkutsk, Ulaan Bataar, Kuala Lumpur, Singapore, Perth, Taipei, Beijing, Chongqing, Hong Kong, Urumqi  |
| <b>(UTC+09:00)</b> | Seoul, Yakutsk, Osaka, Sapporo, Tokyo, Adelaide, Darwin   |
| <b>(UTC+10:00)</b> | Vladivostok, Canberra, Melbourne, Sydney, Guam, Port Moresby, Brisbane, Hobart  |
| <b>(UTC+11:00)</b> | Magadan, Solomon Is., New Caledonia   |
| <b>(UTC+12:00)</b> | Auckland, Wellington, Fiji, Marshall Is., Petropavlovsk-Kamchatsky  |
| <b>(UTC+13:00)</b> | Samoa, Nuku'alofa   |

## List of Function for Each Model

- ➔ [MG series](#)
- ➔ [MX series](#)
- ➔ [E series](#)
- ➔ [P series](#)
- ➔ [iP series](#)
- ➔ [iX series](#)

### MG series

| Model name | Print from E-mail | Google Cloud Print | Canon Inkjet Cloud Printing Center |
|------------|-------------------|--------------------|------------------------------------|
| MG7100     | ✓                 | ✓                  | ✓                                  |
| MG6500     | ✓                 | ✓                  | ✓                                  |
| MG6400     | ✓                 | ✓                  | ✓                                  |
| MG5500     | ✓                 | ✓                  | ✓                                  |
| MG3500     | –                 | ✓                  | –                                  |
| MG2500     | –                 | –                  | –                                  |
| MG2400     | –                 | –                  | –                                  |

### MX series

| Model name | Print from E-mail | Google Cloud Print | Canon Inkjet Cloud Printing Center |
|------------|-------------------|--------------------|------------------------------------|
| MX920      | ✓                 | ✓                  | –                                  |
| MX720      | ✓                 | ✓                  | –                                  |
| MX530      | –                 | ✓                  | ✓                                  |
| MX520      | –                 | ✓                  | –                                  |
| MX470      | –                 | ✓                  | –                                  |
| MX450      | –                 | –                  | –                                  |
| MX390      | –                 | –                  | –                                  |

### E series

| Model name | Print from E-mail | Google Cloud Print | Canon Inkjet Cloud Printing Center |
|------------|-------------------|--------------------|------------------------------------|
| E610       | –                 | –                  | –                                  |
| E560       | –                 | ✓                  | –                                  |
| E400       | –                 | –                  | –                                  |

### P series

| Model name | Print from E-mail | Google Cloud Print | Canon Inkjet Cloud Printing Center |
|------------|-------------------|--------------------|------------------------------------|
| P200       | –                 | –                  | –                                  |

## iP series

| Model name | Print from E-mail | Google Cloud Print | Canon Inkjet Cloud Printing Center |
|------------|-------------------|--------------------|------------------------------------|
| iP8700     | –                 | ✓                  | –                                  |
| iP2800     | –                 | –                  | –                                  |

## iX series

| Model name | Print from E-mail | Google Cloud Print | Canon Inkjet Cloud Printing Center |
|------------|-------------------|--------------------|------------------------------------|
| iX6800     | –                 | ✓                  | –                                  |
| iX6700     | –                 | –                  | –                                  |

# Overview of the Machine

- ➔ [Safety Guide](#)
  - ➔ [Safety Precautions](#)
  - ➔ [Regulatory and Safety Information](#)
- ➔ [Main Components and Basic Operations](#)
  - ➔ [Main Components](#)
  - ➔ [About the Power Supply of the Machine](#)
- ➔ [Loading Paper / Originals](#)
  - ➔ [Loading Paper](#)
  - ➔ [Loading Originals](#)
- ➔ [Replacing a FINE Cartridge](#)
  - ➔ [Replacing a FINE Cartridge](#)
  - ➔ [Checking the Ink Status](#)
- ➔ [Maintenance](#)
  - ➔ [When Printing Becomes Faint or Colors Are Incorrect](#)
  - ➔ [Performing Maintenance from a Computer](#)
  - ➔ [Cleaning the Machine](#)
- ➔ [Changing the Machine Settings](#)
  - ➔ [Changing Machine Settings from Your Computer](#)
  - ➔ [Changing the Machine Settings Using the Operation Panel](#)
- ➔ [Information about Network Connection](#)
  - ➔ [Useful Information about Network Connection](#)
- ➔ [About Network Communication](#)
  - ➔ [Changing and Confirming Network Settings](#)
  - ➔ [Screens for Network Connection of IJ Network Tool](#)
  - ➔ [Other Screens of IJ Network Tool](#)
  - ➔ [Appendix for Network Communication](#)
- ➔ [Tips for Ensuring Optimal Printing Quality](#)
  - ➔ [Useful Information about Ink](#)
  - ➔ [Key Points to Successful Printing](#)
  - ➔ [Be Sure to Make Paper Settings after Loading Paper](#)
  - ➔ [Canceling a Print Job](#)
  - ➔ [Key to Enjoying Consistent Printing Quality](#)
  - ➔ [Precautions for Safe Transport of the Machine](#)
- ➔ [Legal Limitations on Use of Your Product and Use of Images](#)
- ➔ [Specifications](#)

## Safety Guide

- [Safety Precautions](#)
- [Regulatory and Safety Information](#)

## Safety Precautions

### Choosing a location

Do not install the machine in a location that is unstable or subject to excessive vibration.

Do not install the machine in locations that are very humid or dusty, in direct sunlight, outdoors, or close to a heating source.

To avoid the risk of fire or electric shocks, use the machine under the operating environment specified in the On-screen Manual.

Do not place the machine on a thick rug or carpet.

Do not place the machine with its back attached to the wall.

### Power supply

Ensure that the area around the power outlet is kept clear at all times so you can easily unplug the power cord if necessary.

Never remove the plug by pulling on the cord.

Pulling the cord may damage the power cord, leading to possible fire or electrical shock.

Do not use an extension lead/cord.

### Working around the machine

Never put your hands or fingers in the machine while it is printing.

When moving the machine, carry the machine at both ends. In case the machine weighs more than 14 kg, it is recommended to have two people lifting the machine. Accidental dropping of the machine causes injury. For the machine's weight, refer to the On-screen Manual.

Do not place any object on the machine. Especially do not place metal objects (paper clips, staples, etc.) or containers of flammable solvents (alcohol, thinners, etc.) on top of the machine.

Do not transport or use the machine on a slant, vertically or upside-down, as the ink may leak and damage the machine.

### Working around the machine (For the multifunction printer)

When loading a thick book on the Platen Glass, do not press hard on the Document Cover. The Platen Glass may break and cause injury.

### Print Heads/ink tanks and FINE Cartridges

Keep ink tanks out of the reach of children. In case ink\* is accidentally licked or swallowed, rinse out mouth or give one or two glasses of water to drink. If irritation or discomfort occurs, obtain medical advice immediately.

\* Clear Ink contains nitrate salts (For models containing Clear Ink).

In case ink gets in contact with eyes, rinse with water immediately. In case ink gets in contact with skin, wash with soap and water immediately. If irritation to eyes or skin persists, obtain medical advice immediately.

Never touch the electrical contacts on a Print Head or FINE Cartridges after printing.

The metal parts may be very hot and could cause burns.

Do not throw ink tanks and FINE Cartridges into fire.

Do not attempt to disassemble or modify the Print Head, ink tanks, and FINE Cartridges.



## Regulatory and Safety Information

### International ENERGY STAR® Program

As an ENERGY STAR Partner, Canon Inc. has determined that this product meets the ENERGY STAR guidelines for efficiency.



### About the disposal of the battery (For models containing lithium battery)

Dispose of used batteries according to the local regulations.

### Users in the U.S.A.

FCC Notice (U.S.A. Only)

For 120V, 60Hz model

Model Number: K10393 (Contains FCC Approved WLAN Module K30356/K30357)

This device complies with Part 15 of the FCC Rules. Operation is subject to the following two conditions: (1) This device may not cause harmful interference, and (2) this device must accept any interference received, including interference that may cause undesired operation.

Note: This equipment has been tested and found to comply with the limits for a Class B digital device, pursuant to Part 15 of the FCC Rules. These limits are designed to provide reasonable protection against harmful interference in a residential installation. This equipment generates, uses and can radiate radio frequency energy and, if not installed and used in accordance with the instructions, may cause harmful interference to radio communications.

However, there is no guarantee that interference will not occur in a particular installation. If this equipment does cause harmful interference to radio or television reception, which can be determined by turning the equipment off and on, the user is encouraged to try to correct the interference by one or more of the following measures:

Reorient or relocate the receiving antenna.

Increase the separation between the equipment and receiver.

Connect the equipment into an outlet on a circuit different from that to which the receiver is connected.

Consult the dealer or an experienced radio/TV technician for help.

Use of a shielded cable is required to comply with Class B limits in Subpart B of Part 15 of the FCC Rules.

Do not make any changes or modifications to the equipment unless otherwise specified in the manual. If such changes or modifications should be made, you could be required to stop operation of the equipment.

FCC ID: AZDK30356/AZDK30357

Changes or modifications not expressly approved by the party responsible for compliance could void the user's authority to operate equipment.

This transmitter must not be co-located or operating in conjunction with any other antenna or transmitter.

The equipment complies with FCC radiation exposure limits for uncontrolled equipment. This equipment should be installed and operated with minimum distance at least 20cm between the radiator and persons body (excluding extremities: hands, wrists, feet and ankles) and must not be collocated or operated with any other antenna or transmitter.

Canon U.S.A., Inc.  
One Canon Park  
Melville, New York 11747  
1-800-652-2666

## Users in Canada

This device complies with Industry Canada license-exempt RSS standard(s). Operation is subject to the following two conditions:

(1) this device may not cause interference, and (2) this device must accept any interference, including interference that may cause undesired operation of the device.

This equipment complies with IC radiation exposure limits set forth for an uncontrolled environment and meets RSS-102 of the IC radio frequency (RF) Exposure rules. This equipment should be installed and operated keeping the radiator at least 20cm or more away from person's body (excluding extremities: hands, wrists, feet and ankles).

## Pour les usagers résidant au Canada

Le présent appareil est conforme aux CNR d'Industrie Canada applicables aux appareils radio exempts de licence.

L'exploitation est autorisée aux deux conditions suivantes :

(1) l'appareil ne doit pas produire de brouillage, et (2) l'utilisateur de l'appareil doit accepter tout brouillage radioélectrique subi, même si le brouillage est susceptible d'en compromettre le fonctionnement.

Cet équipement est conforme aux limites d'exposition aux rayonnements énoncées pour un environnement non contrôlé et respecte les règles d'exposition aux fréquences radioélectriques (RF) CNR-102 de l'IC. Cet équipement doit être installé et utilisé en gardant une distance de 20 cm ou plus entre le dispositif rayonnant et le corps (à l'exception des extrémités : mains, poignets, pieds et chevilles).

## Users in Jordan

This printer contains WLAN Module (K30356) approved by TRC/SS/2013/36 or WLAN Module (K30357) approved by TRC/LPD/2013/130

## European Union (and EEA) only.



This symbol indicates that this product is not to be disposed of with your household waste, according to the WEEE Directive (2002/96/EC) and your national law. This product should be handed over to a designated collection point, e.g., on an authorized one-for-one basis when you buy a new similar product or to an authorized collection site for recycling waste electrical and electronic equipment (EEE). Improper handling of this type of waste could have a possible negative impact on the environment and human health due to potentially hazardous substances that are generally associated with EEE. At the same time, your cooperation in the correct disposal of this product will contribute to the effective usage of natural resources. For more information about where you can drop off your waste equipment for recycling, please contact your local city office, waste authority, approved WEEE scheme or your household waste disposal service. For more information regarding return and recycling of WEEE products, please visit [www.canon-europe.com/environment](http://www.canon-europe.com/environment).

(EEA: Norway, Iceland and Liechtenstein)

## India only.



This product is not to be disposed of with your household waste, according to the e-waste (Management and Handling) Rules, 2011.

This product should be handed over to a designated collection point, e.g., to an authorized collection site for recycling waste electrical and electronic equipment (EEE). Improper handling of this type of waste could have a possible negative

impact on the environment and human health due to potentially hazardous substances that are generally associated with EEE. At the same time, your cooperation in the correct disposal of this product will contribute to the effective usage of natural resources. For more information regarding return and recycling of WEEE products, please visit <http://www.canon.co.in/environment/>.

Also, this product complies with the "India E-waste Rule 2011" and prohibits use of lead, mercury, hexavalent chromium, polybrominated biphenyls or polybrominated diphenyl ethers in concentrations exceeding 0.1 % by weight and 0.01 % by weight for Cadmium, except for the exemptions set in Schedule II of the Rule.

## **Environmental Information**

Reducing your environmental impact while saving money

### **Power Consumption and Activation Time**

The amount of electricity a device consumes depends on the way the device is used. This product is designed and set in a way to allow you to reduce your electricity costs. After the last print it switches to Ready Mode. In this mode it can print again immediately if required. If the product is not used for a time, the device switches to its Power Save Mode. The devices consume less power (Watt) in these modes.

If you wish to set a longer Activation Time or would like to completely deactivate the Power Save Mode, please consider that this device may then only switch to a lower energy level after a longer period of time or not at all.

Canon does not recommend extending the Activation Times from the optimum ones set as default.

### **Energy Star®**

The Energy Star® programme is a voluntary scheme to promote the development and purchase of energy efficient models, which help to minimise environmental impact.

Products which meet the stringent requirements of the Energy Star® programme for both environmental benefits and the amount of energy consumption will carry the Energy Star® logo accordingly.

### **Paper types**

This product can be used to print on both recycled and virgin paper (certified to an environmental stewardship scheme), which complies with EN12281 or a similar quality standard. In addition it can support printing on media down to a weight of 64g/m<sup>2</sup>, lighter paper means less resources used and a lower environmental footprint for your printing needs.



## Main Components and Basic Operations

- [Main Components](#)
- [About the Power Supply of the Machine](#)

## Main Components

- Front View
- Rear View
- Inside View
- Operation Panel

## Front View

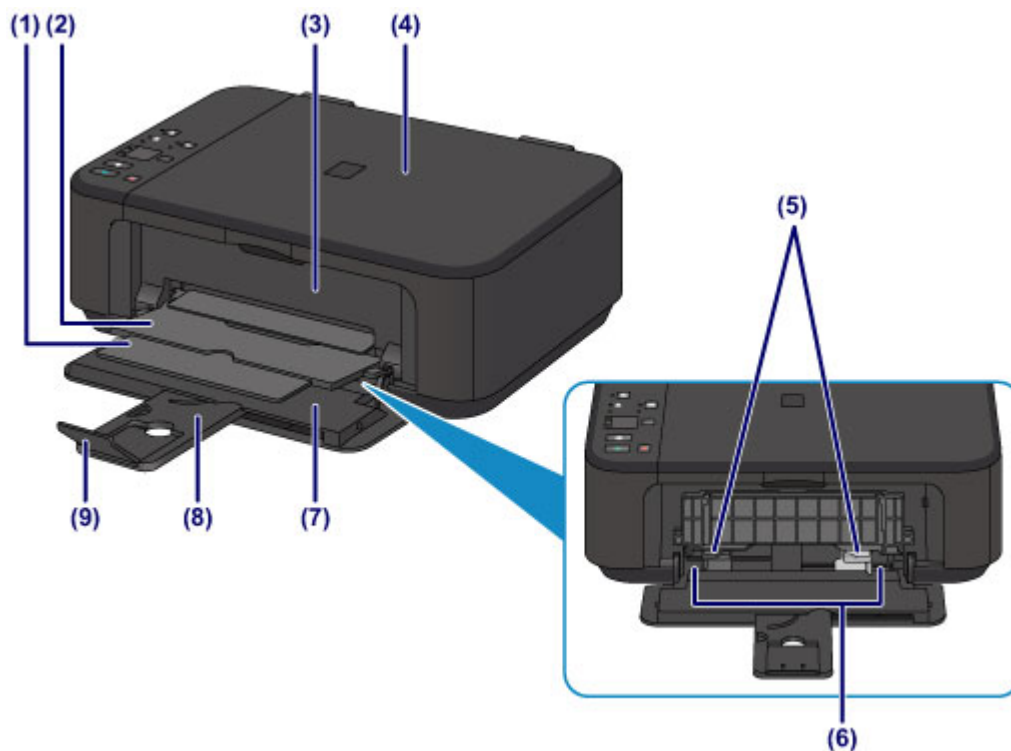

**(1) paper output support**

Extend to support ejected paper.

**(2) paper output tray**

Printed paper is ejected.

**(3) paper output cover**

Open to replace the FINE cartridge or remove jammed paper inside the machine.

**(4) document cover**

Open to load an original on the platen glass.

**(5) paper guides**

Slide to align with both sides of the paper stack.

**(6) front tray**

Load various sizes or types of paper which you can use on the machine. Two or more sheets of the same size and type of paper can be loaded at the same time, and fed automatically one sheet at a time.

➡ [Loading Plain Paper / Photo Paper](#)

➡ [Loading Envelopes](#)

**(7) front cover**

Open to load paper in the front tray.

**(8) paper support**

Extend to load paper in the front tray.

**(9) output tray extension**

Open to support ejected paper.

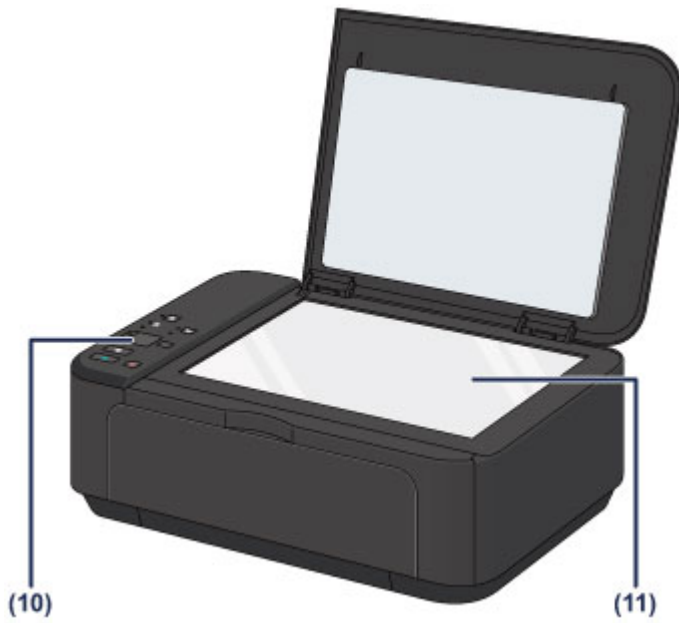

**(10) operation panel**

Use to change the settings of the machine or to operate it.

➡ [Operation Panel](#)

**(11) platen glass**

Load an original to copy or scan.

## Rear View

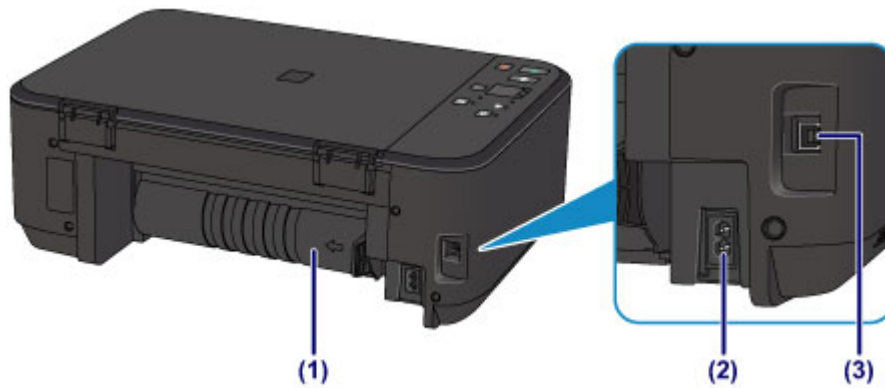

**(1) transport unit**

Open to remove jammed paper.

**(2) power cord connector**

Plug in the supplied power cord.

**(3) USB port**

Plug in the USB cable to connect the machine with a computer.

**▶▶ Important**

- Do not touch the metal casing.
- Do not plug in or unplug the USB cable while the machine is printing or scanning originals with the computer.



## Inside View

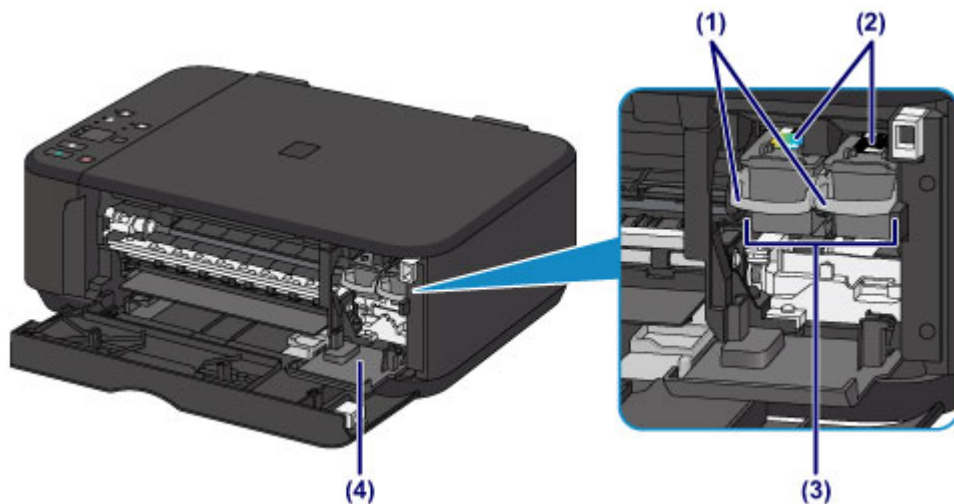

### (1) ink cartridge lock lever

Locks the FINE cartridge into place.

### (2) FINE cartridge (ink cartridges)

A replaceable cartridge that integrates print head and ink tank.

### (3) FINE cartridge holder

Install the FINE cartridge.

The color FINE cartridge should be installed into the left slot and the black FINE cartridge should be installed into the right slot.

### (4) head cover

Opens to enable replacement of the FINE cartridge. The head cover will open automatically when you open the paper output cover.

## ►► Note

- For details on replacing a FINE cartridge, see [Replacing a FINE Cartridge](#).

## ►► Important

- The area around the parts (A) may be splattered with ink. This does not affect the performance of the machine.
- Do not touch the parts (A) or the electrical contacts (B) behind them. The machine may not print properly if you touch them.

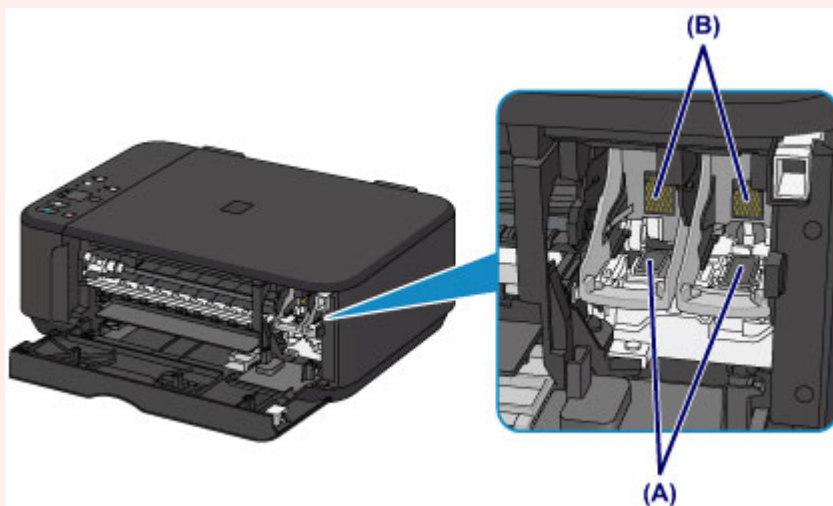

# Operation Panel

\* The Wi-Fi and **Alarm** lamps are shown lit in the illustration below for explanatory purposes.

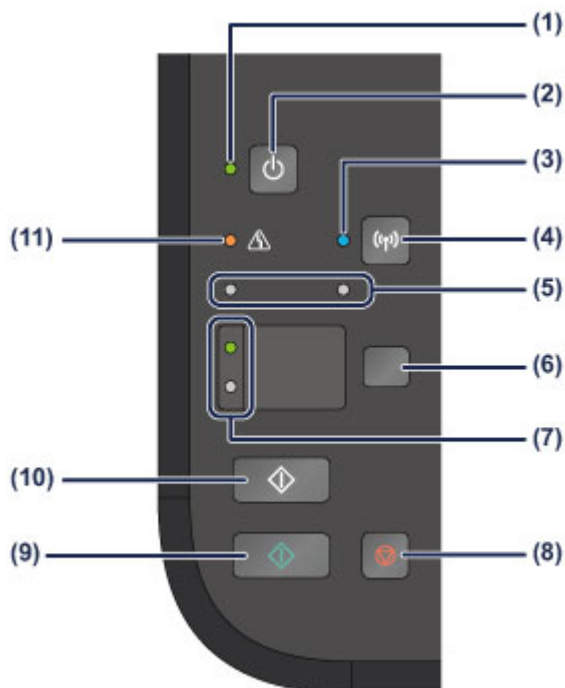

## (1) ON lamp

Lights green after flashing when the power is turned on.

### ▶▶▶ Note

#### ON and Alarm lamps

- You can check the status of the machine by the **ON** and **Alarm** lamps.
  - **ON** lamp is off: The power is off.
  - **ON** lamp lights green: The machine is ready to print.
  - **ON** lamp flashes green: The machine is getting ready to print, or printing is in progress.
  - **Alarm** lamp flashes orange: An error has occurred and the machine is not ready to print.
  - ➡ "Support Code Corresponding to the Number of Flashes of the Alarm Lamp" in If an Error Occurs
  - **ON** lamp flashes green and **Alarm** lamp flashes orange alternately: An error that requires contacting the service center may have occurred.
  - ➡ "Support Code Corresponding to the Number of Alternate Flashes of the ON Lamp and the Alarm Lamp" in If an Error Occurs

## (2) ON button

Turns the power on or off. Before turning on the power, make sure that the document cover is closed.

➡ [Turning the Machine On and Off](#)

## (3) Wi-Fi lamp

Lights or flashes blue to indicate the wireless LAN status.

Lights:

Wireless LAN connection is enabled.

Flashes:

Printing or scanning over wireless LAN. Also flashes while configuring the wireless LAN connection.

## (4) Wi-Fi button

Hold down to automatically set up the wireless LAN connection.

## (5) ink lamps

Light or flash orange when ink runs out, etc.

The left lamp indicates the color FINE cartridge status, the right lamp the black FINE cartridge status.

**(6) Paper button**

Selects the page size and media type.

**(7) Paper lamp**

Lights to indicate the page size and media type selected with the **Paper** button.

**(8) Stop button**

Cancels operations. You can press this button to cancel a print, copy, or scan job in progress. Holding this button down lets you select maintenance options or machine settings.

**(9) Color button\***

Starts color copying. You can also press this button to finalize your selection for the setting item.

**(10) Black button\***

Starts black & white copying. You can also press this button to finalize your selection for the setting item.

**(11) Alarm lamp**

Lights or flashes orange when an error occurs, such as paper-out or ink-out. When performing machine maintenance or machine settings, options can be selected according to the number of flashes.

\* In the software applications or manuals, the **Color** and **Black** buttons are collectively called the "Start" or "OK" button.

## About the Power Supply of the Machine

- Confirming that the Power Is On
- Turning the Machine On and Off
- Notice for the Power Plug/Power Cord
- Notice for Unplugging the Power Cord

## Confirming that the Power Is On

The **ON** lamp is lit green when the machine is turned on.

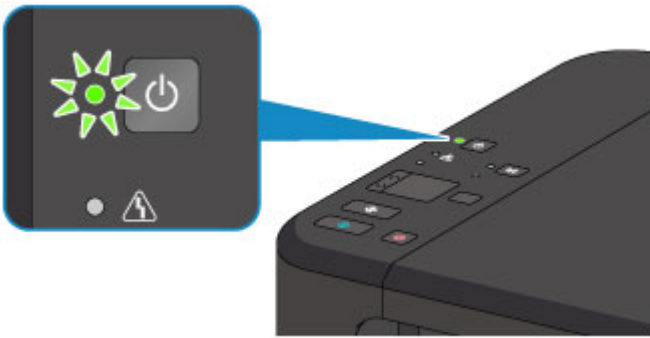

### ▶▶ Note

- It may take a while for the machine to start printing immediately after you turn on the machine.

# Turning the Machine On and Off

## Turning on the machine

1. Press the **ON** button to turn on the machine.

The **ON** lamp flashes and then remains lit green.

➡ [Confirming that the Power Is On](#)

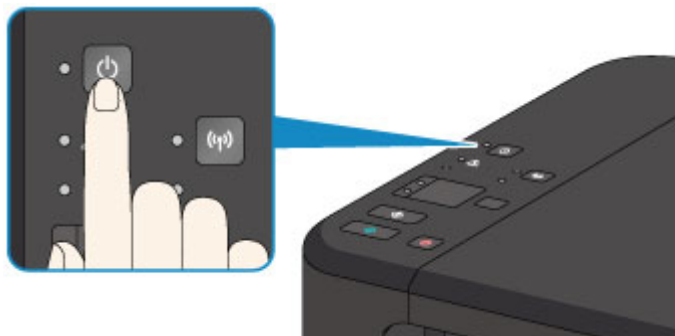

### ➤➤➤ Note

- It may take a while for the machine to start printing immediately after you turn on the machine.
- If the **Alarm** lamp lights up or flashes orange, see [If an Error Occurs](#).

#### Auto power on feature

- You can set the machine to automatically turn on when a print or scan operation is performed from a computer connected by USB cable or wireless network. This feature is set to off by default.

➡ [Managing the Machine Power](#)

## Turning off the machine

1. Press the **ON** button to turn off the machine.

When the **ON** lamp stops flashing, the machine is turned off.

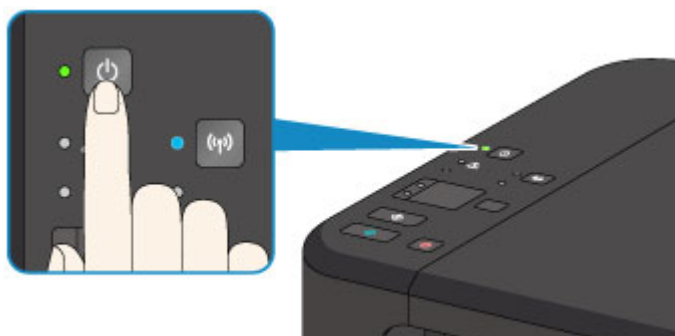

### ➤➤➤ Important

- When you unplug the power cord after turning off the machine, be sure to confirm that the **ON** lamp is off.
- ➡ [Notice for Unplugging the Power Cord](#)

### ➤➤➤ Note

#### Auto power off feature

- You can set the machine to automatically turn off when no operations are performed or no print jobs are sent to the machine for a certain interval. This is the default setting.

➡ [Managing the Machine Power](#)

## Notice for the Power Plug/Power Cord

Unplug the power cord once a month to confirm that the power plug/power cord does not have anything unusual described below.

- The power plug/power cord is hot.
- The power plug/power cord is rusty.
- The power plug/power cord is bent.
- The power plug/power cord is worn.
- The power plug/power cord is split.

### **Caution**

- If you find anything unusual with the power plug/power cord described above, unplug the power cord and call for service. Using the machine with one of the unusual conditions above may cause a fire or an electric shock.
  - ➔ [Notice for Unplugging the Power Cord](#)

## Notice for Unplugging the Power Cord

To unplug the power cord, follow the procedure below.

### ▶▶▶ Important

- When you unplug the power cord, press the **ON** button, then confirm that the **ON** lamp is off. Unplugging the power cord while the **ON** lamp is lit or flashing may cause drying or clogging of the print head and print quality may be reduced.

1. Press the **ON** button to turn the machine off.

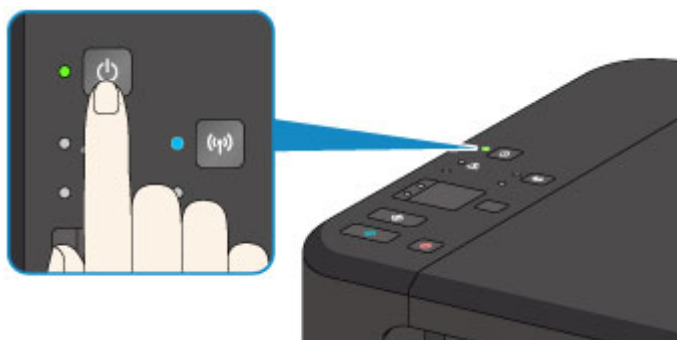

2. Confirm that the **ON** lamp is off.

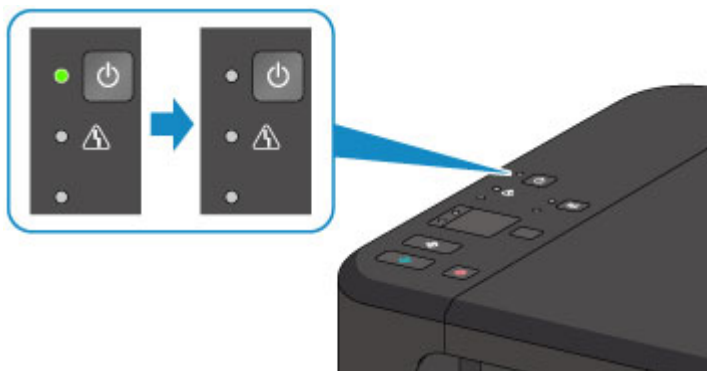

3. Unplug the power cord.

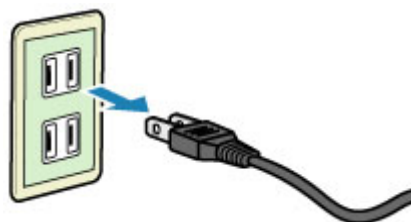

The specification of the power cord differs depending on the country or region of use.



## Loading Paper / Originals

- Loading Paper
- Loading Originals

## Loading Paper

- [Loading Plain Paper / Photo Paper](#)
- [Loading Envelopes](#)
- [Media Types You Can Use](#)
- [Media Types You Cannot Use](#)
- [Printing Area](#)

## Loading Plain Paper / Photo Paper

You can load plain paper or photo paper.

### ►►► Important

- If you cut plain paper into small size such as 4" x 6" (10 x 15 cm) or 5" x 7" (13 x 18 cm) to perform trial print, it can cause paper jams.

### ►►► Note

- We recommend Canon genuine photo paper for printing photos.  
For details on the Canon genuine paper, see [Media Types You Can Use](#).
- You can use general copy paper.  
For the page size and paper weight you can use for this machine, see [Media Types You Can Use](#).

### 1. Prepare paper.

Align the edges of paper. If paper is curled, flatten it.

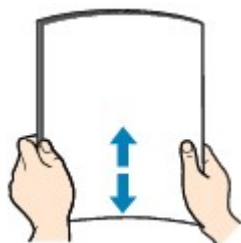

### ►►► Note

- Align the edges of paper neatly before loading. Loading paper without aligning the edges may cause paper jams.
- If paper is curled, hold the curled corners and gently bend them in the opposite direction until the paper becomes completely flat.  
For details on how to flatten curled paper, see "Load the paper after correcting its curl." in Paper Is Smudged/ Printed Surface Is Scratched.
- When using Photo Paper Plus Semi-gloss SG-201, even if the sheet is curled, load one sheet at a time as it is. If you roll up this paper to flatten, this may cause cracks on the surface of the paper and reduce the print quality.

### 2. Load paper.

(1) Open the front cover gently, and extend the paper support.

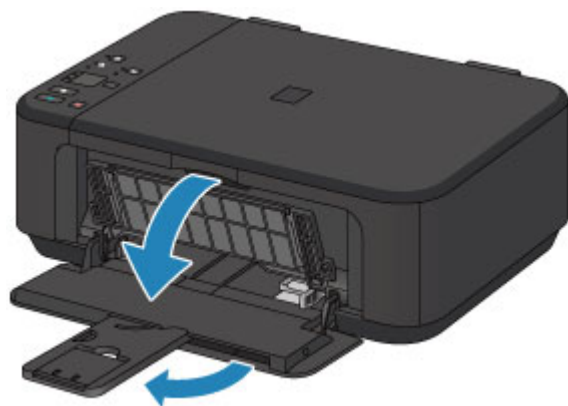

(2) Use the right paper guide (A) to slide both paper guides all the way out.

(3) Load the paper in the center of the front tray WITH THE PRINT SIDE FACING DOWN.

Push the paper stack all the way to the back of the front tray.

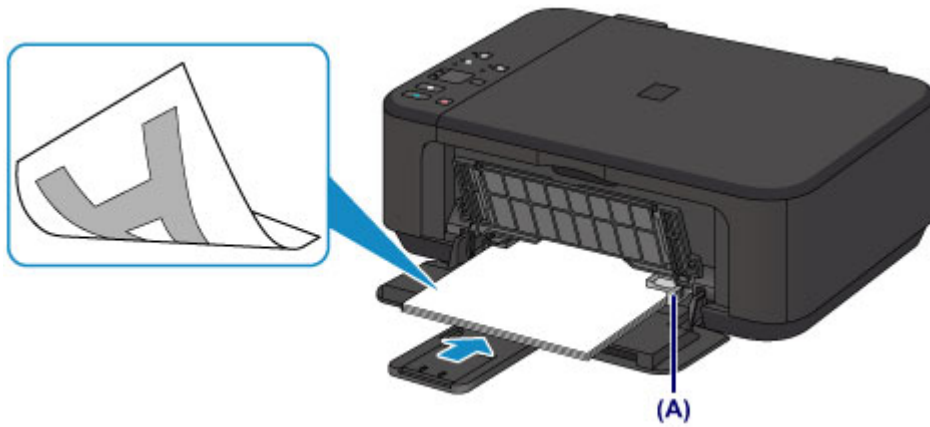

- (4) Slide the right paper guide (A) to align the paper guides with both sides of the paper stack. Do not slide the paper guides too hard against the paper. The paper may not be fed properly.

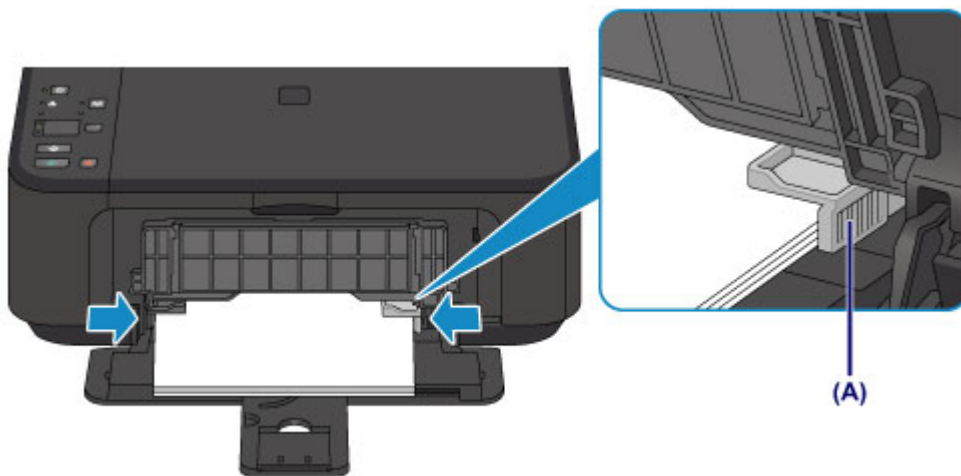

### ►► Important

- Always load paper in the portrait orientation (B). Loading paper in the landscape orientation (C) can cause paper jams.

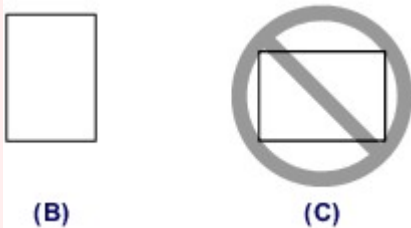

### ►► Note

- Do not overload paper by stacking until the top of the stack touches the paper guides.
- Load small size paper, such as 4" x 6" (10 x 15 cm), by pushing it in all the way to the back of the front tray.

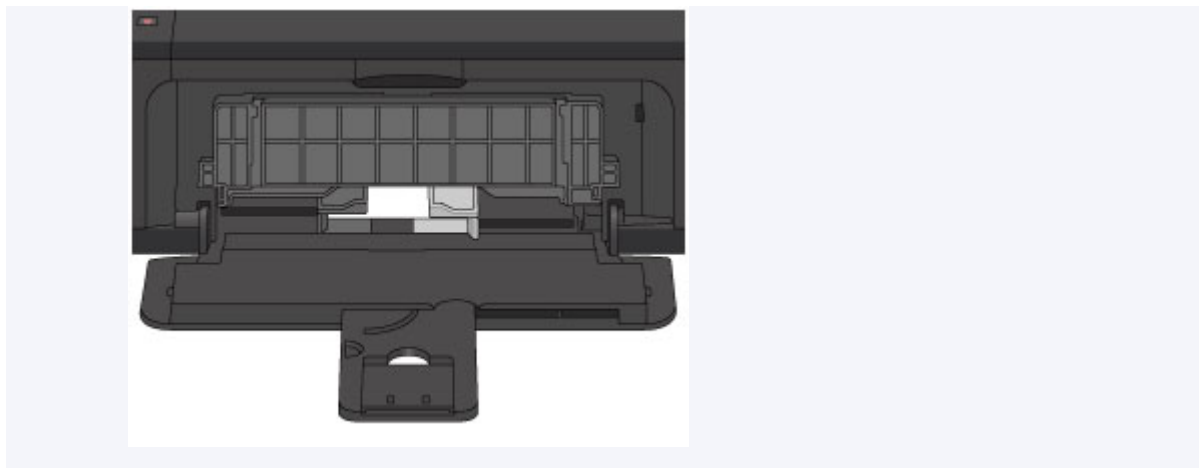

(5) Open the output tray extension.

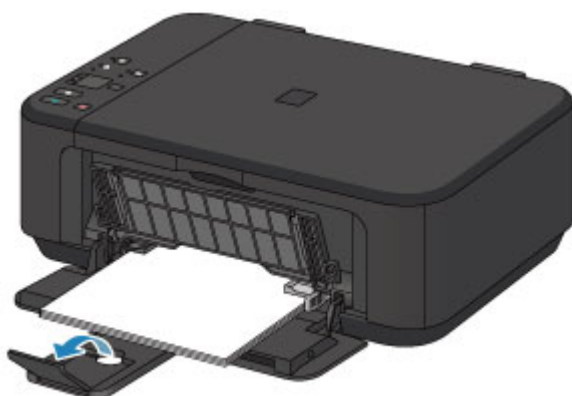

3. Open the paper output tray.

(1) Open the paper output tray gently, and extend the paper output support.

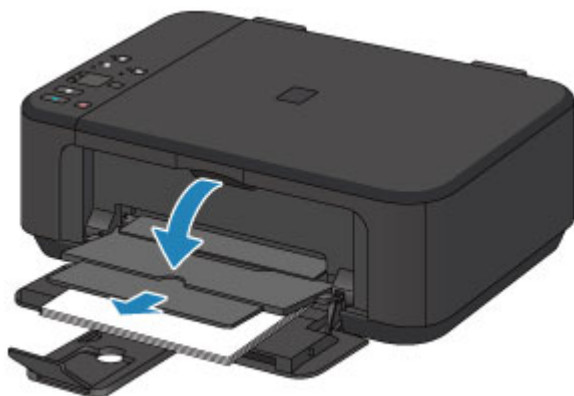

**Important**

- Be sure to open the paper output tray when printing. If not open, the machine cannot start printing.

**Note**

**After loading paper**

- Select the size and type of the loaded paper on the print settings screen of the operation panel or printer driver.

# Loading Envelopes

You can load Envelope DL and Envelope Com 10.

The address is automatically rotated and printed according to the envelope's direction by specifying with the printer driver properly.

## Important

- Printing of envelopes from the operation panel is not supported.
- Do not use the following envelopes. They could jam in the machine or cause the machine to malfunction.
  - Envelopes with an embossed or treated surface
  - Envelopes with a double flap
  - Envelopes whose gummed flaps are already moistened and adhesive

### 1. Prepare envelopes.

- Press down on all four corners and edges of the envelopes to flatten them.

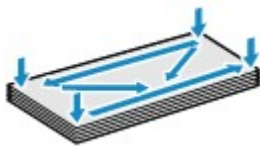

- If the envelopes are curled, hold the opposite corners and gently twist them in the opposite direction.



- If the corner of the envelope flap is folded, flatten it.
- Use a pen to press the leading edge in the inserting direction flat and sharpen the crease.

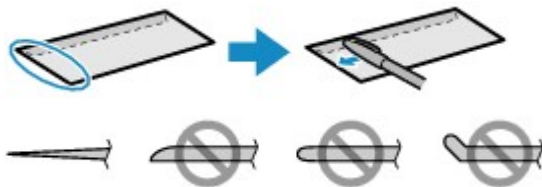

The figures above show a side view of the leading edge of the envelope.

## Important

- The envelopes may jam in the machine if they are not flat or the edges are not aligned. Make sure that no curl or puff exceeds 0.1 inches (3 mm).

### 2. Load envelopes.

- (1) Open the front cover gently, and extend the paper support.

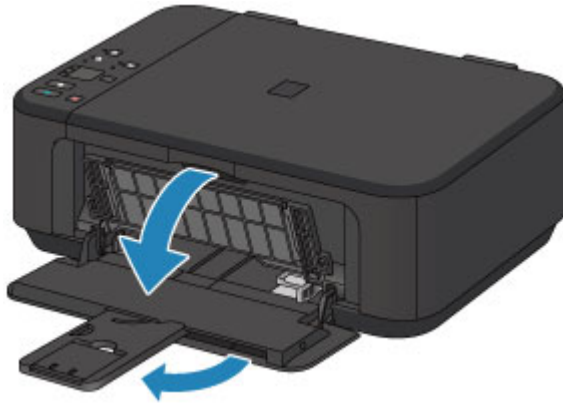

(2) Use the right paper guide (A) to slide both paper guides all the way out.

(3) Load the envelopes in the center of the front tray WITH THE ADDRESS SIDE FACING DOWN.

The folded flap of the envelope will be faced up on the left side.

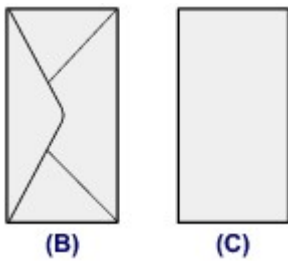

(B) Rear side

(C) Address side

Push the envelopes all the way to the back of the front tray.

Up to 5 envelopes can be loaded at once.

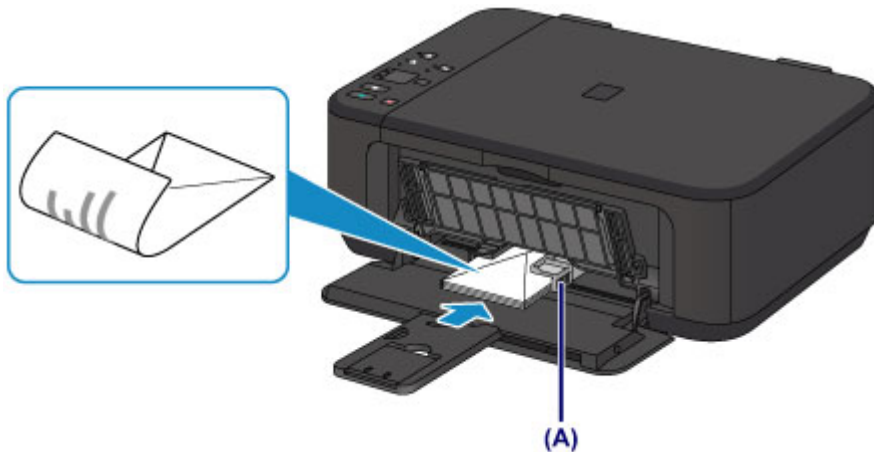

(4) Slide the right paper guide (A) to align the paper guides with both sides of the envelopes.

Do not slide the paper guides too hard against the envelopes. The envelopes may not be fed properly.

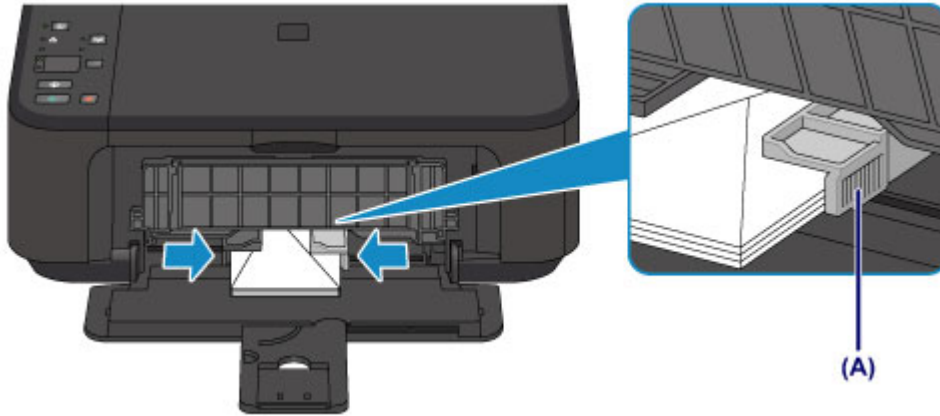

»»» **Note**

- Do not overload envelopes by stacking until the top of the stack touches the paper guides.

(5) Open the output tray extension.

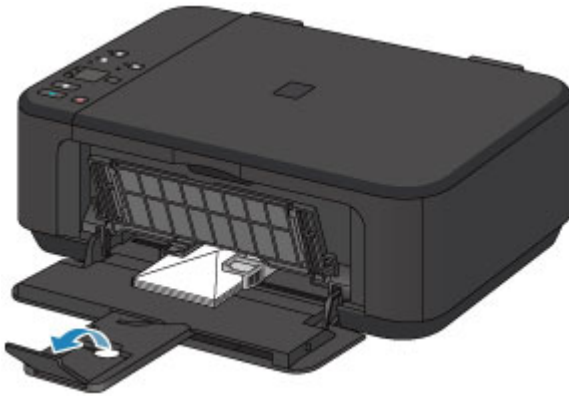

3. Open the paper output tray.

(1) Open the paper output tray gently, and extend the paper output support.

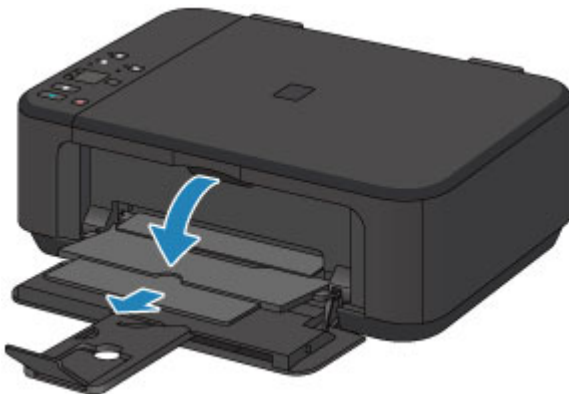

»»» **Important**

- Be sure to open the paper output tray when printing. If not open, the machine cannot start printing.

»»» **Note**

**After loading envelopes**

- Select the size and type of the loaded envelopes on the print settings screen of the printer driver.



## Media Types You Can Use

Choose paper suitable for printing, for the best print results. Canon provides you various types of paper to enhance the fun of printing, such as stickers as well as papers for photo or document. We recommend the use of Canon genuine paper for printing your important photos.

### Media Types

#### Commercially available papers

- Plain Paper (including recycled paper)<sup>\*1 \*2</sup>
- Envelopes

#### Canon genuine papers

The Model Number of Canon genuine paper is shown in brackets. Refer to the instruction manual supplied with the paper for detailed information on the printable side and notes on handling paper. For information on the page sizes available for each Canon genuine paper, access our website.

#### ▶▶▶ Note

- You may not be able to purchase some Canon genuine papers depending on the country or region of purchase. Paper is not sold in the US by Model Number. Purchase paper by name.

#### Paper for printing photos:

- Photo Paper Pro Platinum <PT-101>
- Glossy Photo Paper "Everyday Use" <GP-501/GP-601><sup>\*2</sup>
- Photo Paper Glossy <GP-601><sup>\*2</sup>
- Photo Paper Plus Glossy II <PP-201><sup>\*2</sup>
- Photo Paper Pro Luster <LU-101><sup>\*2</sup>
- Photo Paper Plus Semi-gloss <SG-201><sup>\*2</sup>
- Matte Photo Paper <MP-101>

#### Paper for printing business documents:

- High Resolution Paper <HR-101N>

#### Paper for creating your own prints:

- T-Shirt Transfers <TR-301>
- Photo Stickers <PS-101>

\*1 100% recycled paper can be used.

\*2 This paper is also available for making copies. Select with the **Paper** button on the operation panel. You can select only A4 or Letter-sized plain paper or 4" x 6" (10 x 15 cm) photo paper.

➡ [Paper Load Limit](#)

➡ [Setting the Media Type with the Printer Driver](#)

### Page Sizes

You can use the following page sizes.

## ►► Note

- Only the following sizes may be printed from the operation panel.
  - A4, Letter, and 4" x 6" (10 x 15 cm)

### Standard sizes:

- Letter
- A5
- B5
- 5" x 7" (13 x 18 cm)
- Envelope DL
- Legal
- A4
- 4" x 6" (10 x 15 cm)
- 8" x 10" (20 x 25 cm)
- Envelope Com 10

### Non-standard sizes:

You can print on non-standard size paper within the following ranges.

- Minimum size: 3.50 x 5.00 inches (89.0 x 127.0 mm)
- Maximum size: 8.50 x 26.61 inches (215.9 x 676.0 mm)

### Paper Weight

You can use paper in the following weight range.

- 17 to 28 lb (64 to 105 g /m<sup>2</sup>) (except for Canon genuine paper)

Do not use heavier or lighter paper (except for Canon genuine paper), as it could jam in the machine.

### Notes on Storing Paper

- Take out only the necessary number of paper from the package, just before printing.
- To avoid curling, when you do not print, put unused paper back into the package and keep it on a level surface. And also, store it avoiding heat, humidity, and direct sunlight.

## Paper Load Limit

### Commercially Available Papers

| Media Name   | Front Tray         | Paper Output Tray |
|--|--------------------|-------------------|
| Plain Paper (including recycled paper) <sup>*1</sup> | Approx. 100 sheets | Approx. 50 sheets |
| Envelopes  | 5 envelopes        | <sup>*2</sup>     |

### Canon Genuine Papers

#### ▶▶▶ Note

- We recommend that you remove the previously printed sheet from the paper output tray before continuously printing to avoid blurs and discoloration (except for High Resolution Paper <HR-101N>).

### Paper for printing photos:

| Media Name <Model No.>  | Front Tray  |
|---|---|
| Photo Paper Pro Platinum <PT-101> <sup>*3</sup>                 | 10 sheets: A4, Letter, and 8" x 10" (20 x 25 cm)<br>20 sheets: 4" x 6" (10 x 15 cm)                       |
| Glossy Photo Paper "Everyday Use" <GP-501/GP-601> <sup>*3</sup> | 10 sheets: A4 and Letter<br>20 sheets: 4" x 6" (10 x 15 cm)   |
| Photo Paper Glossy <GP-601> <sup>*3</sup>                       | 10 sheets: A4 and Letter<br>20 sheets: 4" x 6" (10 x 15 cm)   |
| Photo Paper Plus Glossy II <PP-201> <sup>*3</sup>               | 10 sheets: A4, Letter, 5" x 7" (13 x 18 cm), and 8" x 10" (20 x 25 cm)<br>20 sheets: 4" x 6" (10 x 15 cm) |
| Photo Paper Pro Luster <LU-101> <sup>*3</sup>                   | 10 sheets: A4 and Letter  |
| Photo Paper Plus Semi-gloss <SG-201> <sup>*3</sup>              | 10 sheets: A4, Letter, 5" x 7" (13 x 18 cm), and 8" x 10" (20 x 25 cm)<br>20 sheets: 4" x 6" (10 x 15 cm) |
| Matte Photo Paper <MP-101>                                      | 10 sheets: A4 and Letter<br>20 sheets: 4" x 6" (10 x 15 cm)   |

### Paper for printing business documents:

| Media Name <Model No.>          | Front Tray | Paper Output Tray |
|---------------------------------|------------|-------------------|
| High Resolution Paper <HR-101N> | 80 sheets  | 50 sheets         |

### Paper for creating your own prints:

| Media Name <Model No.>     | Front Tray |
|----------------------------|------------|
| T-Shirt Transfers <TR-301> | 1 sheet    |
| Photo Stickers <PS-101>    | 1 sheet    |

\*1 Proper feeding of paper may not be possible at the maximum capacity depending on the type of paper or environmental conditions (either very high or low temperature or humidity). In such cases, reduce the number of paper you load at a time to less than half.

\*2 We recommend that you remove the previously printed envelope from the paper output tray before continuously printing to avoid blurs and discoloration.

\*3 When loading paper in stacks, the print side may become marked as it is fed or paper may not feed properly. In this case, load one sheet at a time.

## Media Types You Cannot Use

Do not use the following types of paper. Using such paper will cause not only unsatisfactory results, but also the machine to jam or malfunction.

- Folded, curled, or wrinkled paper
- Damp paper
- Paper that is too thin (weighing less than 17 lb (64 g /m<sup>2</sup>))
- Paper that is too thick (weighing more than 28 lb (105 g /m<sup>2</sup>), except for Canon genuine paper)
- Paper thinner than a postcard, including plain paper or notepad paper cut to a small size (when printing on paper smaller than A5)
- Picture postcards
- Postcards affixed with photos or stickers
- Envelopes with a double flap
- Envelopes with an embossed or treated surface
- Envelopes whose gummed flaps are already moistened and adhesive
- Any type of paper with holes
- Paper that is not rectangular
- Paper bound with staples or glue
- Paper with adhesives
- Paper decorated with glitter, etc.

## Printing Area

- Printing Area
- Other Sizes than Letter, Legal, Envelopes
- Letter, Legal
- Envelopes

## Printing Area

To ensure the best print quality, the machine allows a margin along each edge of media. The actual printable area will be the area inside these margins.

Recommended printing area  : Canon recommends that you print within this area.

Printable area  : The area where it is possible to print.

However, printing in this area can affect the print quality or the paper feed precision.

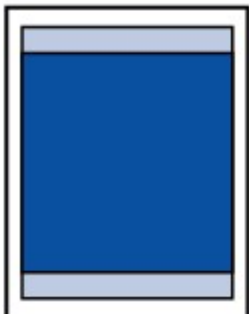

### ►► Note

- With performing Automatic Duplex Printing, the printable area will be 0.08 inches (2 mm) smaller at the top margin.

#### Borderless Printing

- By selecting Borderless Printing option, you can make prints with no margins.
- When performing Borderless Printing, slight cropping may occur at the edges since the printed image is enlarged to fill the whole page.
- For Borderless Printing, use the following paper:
  - Photo Paper Pro Platinum <PT-101>
  - Glossy Photo Paper "Everyday Use" <GP-501/GP-601>
  - Photo Paper Glossy <GP-601>
  - Photo Paper Plus Glossy II <PP-201>
  - Photo Paper Pro Luster <LU-101>
  - Photo Paper Plus Semi-gloss <SG-201>
  - Matte Photo Paper <MP-101>

Performing Borderless Printing on any other type of paper may substantially reduce printing quality and/or result in printouts with altered color hues.

Borderless Printing on plain paper may result in printouts with reduced quality. Use them only for test printing.

Borderless Printing onto plain paper from the operation panel is not supported.

- Borderless Printing is not available for legal, A5, or B5 sized paper, or envelopes.
- Depending on the type of paper, Borderless Printing may reduce the print quality at the top and bottom edges of the paper or cause these parts to become smudged.

## Other Sizes than Letter, Legal, Envelopes

| Size                  | Printable Area (width x height)        |
|-----------------------|--|
| A5                    | 5.56 x 7.95 inches (141.2 x 202.0 mm)  |
| A4                    | 8.00 x 11.38 inches (203.2 x 289.0 mm) |
| B5                    | 6.90 x 9.80 inches (175.2 x 249.0 mm)  |
| 4" x 6" (10 x 15 cm)  | 3.73 x 5.69 inches (94.8 x 144.4 mm)   |
| 5" x 7" (13 x 18 cm)  | 4.73 x 6.69 inches (120.2 x 169.8 mm)  |
| 8" x 10" (20 x 25 cm) | 7.73 x 9.69 inches (196.4 x 246.0 mm)  |

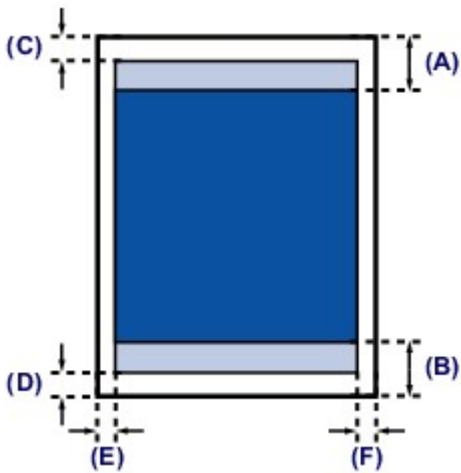

Recommended printing area

**(A)** 1.28 inches (32.5 mm)

**(B)** 1.32 inches (33.5 mm)

Printable area

**(C)** 0.12 inches (3.0 mm)

**(D)** 0.20 inches (5.0 mm)

**(E)** 0.13 inches (3.4 mm)

**(F)** 0.13 inches (3.4 mm)



## Letter, Legal

| Size   | Printable Area (width x height)        |
|--------|--|
| Letter | 8.00 x 10.69 inches (203.2 x 271.4 mm) |
| Legal  | 8.00 x 13.69 inches (203.2 x 347.6 mm) |

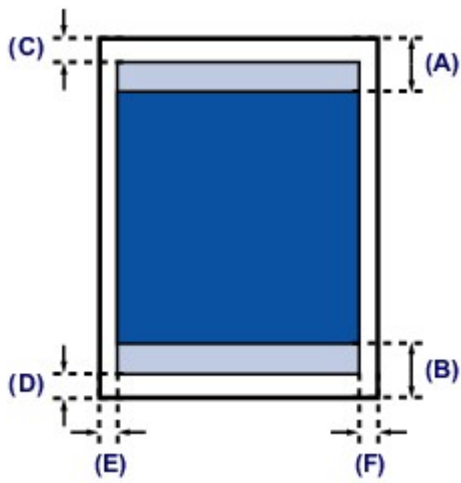

 Recommended printing area

(A) 1.28 inches (32.5 mm)

(B) 1.32 inches (33.5 mm)

 Printable area

(C) 0.12 inches (3.0 mm)

(D) 0.20 inches (5.0 mm)

(E) 0.25 inches (6.4 mm)

(F) 0.25 inches (6.3 mm)

## Envelopes

| Size            | Recommended Printing Area (width x height) |
|-----------------|--|
| Envelope DL     | 3.88 x 7.06 inches (98.8 x 179.5 mm)       |
| Envelope Com 10 | 3.68 x 7.90 inches (93.5 x 200.8 mm)       |

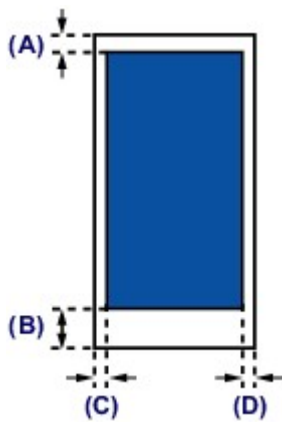

 Recommended printing area

(A) 0.31 inches (8.0 mm)

(B) 1.28 inches (32.5 mm)

(C) 0.22 inches (5.6 mm)

(D) 0.22 inches (5.6 mm)

## Loading Originals

- [Loading Originals on the Platen Glass](#)
- [Originals You Can Load](#)
- [How to Detach / Attach the Document Cover](#)

## Loading Originals on the Platen Glass

You can load originals to copy or scan on the platen glass.

1. Load an original on the platen glass.

(1) Open the document cover.

(2) Load the original WITH THE SIDE TO SCAN FACING DOWN on the platen glass.

➡ [Originals You Can Load](#)

Align the corner of the original with the alignment mark .

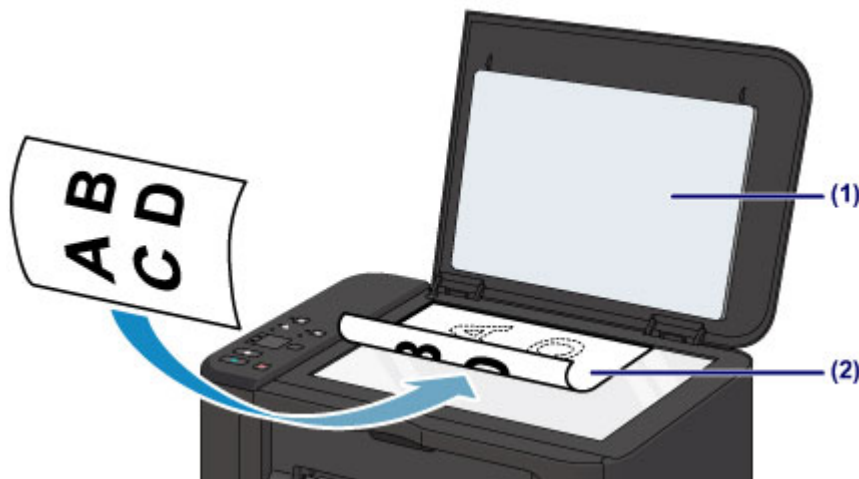

### Important

- Be sure to observe the following when loading the original on the platen glass.
  - Do not place any objects weighing 4.4 lb (2.0 kg) or more on the platen glass.
  - Do not put any pressure of 4.4 lb (2.0 kg) or more on the platen glass, such as pressing down the original. Failure to observe the above may cause the scanner to malfunction or the platen glass to break.
- The machine cannot scan the shaded area (A) (0.04 inches (1 mm) from the edges of the platen glass).

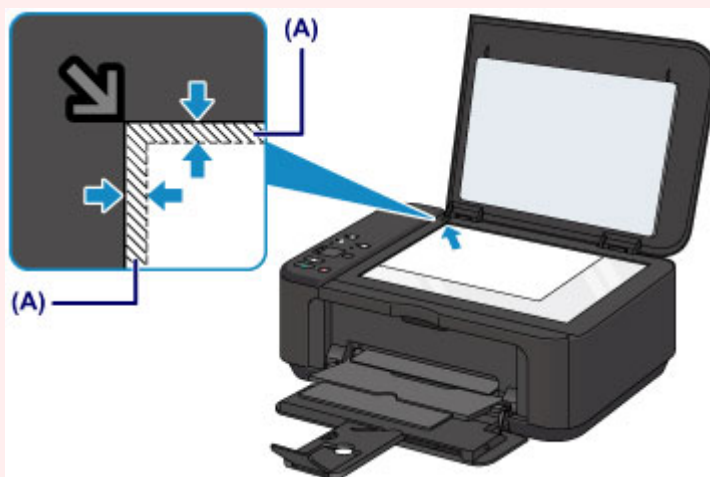

2. Close the document cover gently.

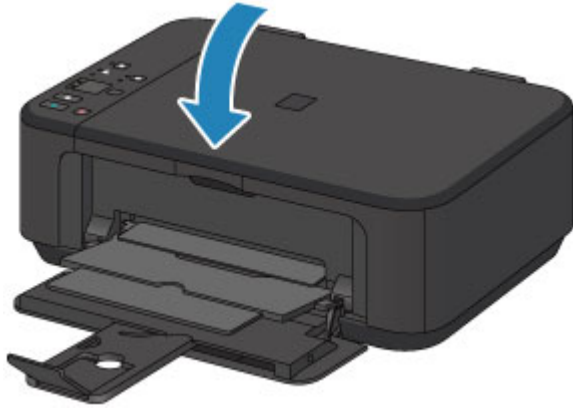

**»» Important**

- After loading the original on the platen glass, be sure to close the document cover before starting to copy or scan.

## Originals You Can Load

The originals you can load on the platen glass are as follows.

| Item                  | Details  |
|-----------------------|--|
| Types of originals    | - Text document, magazine, or newspaper<br>- Printed photo, postcard, business card, or disc (BD/DVD/CD, etc.) |
| Size (width x height) | Max. 8.5 x 11.7 inches (216 x 297 mm)  |

### Note

- When loading a thick original such as a book on the platen glass, you can load it by removing the document cover from the machine.
  - ➔ [How to Detach / Attach the Document Cover](#)

## How to Detach / Attach the Document Cover

### Detaching the document cover:

Hold the document cover vertically and then pull it up.



### Attaching the document cover:

Fit both hinges (A) of the document cover into the holder (B) and insert both hinges of the document cover vertically as illustrated below.

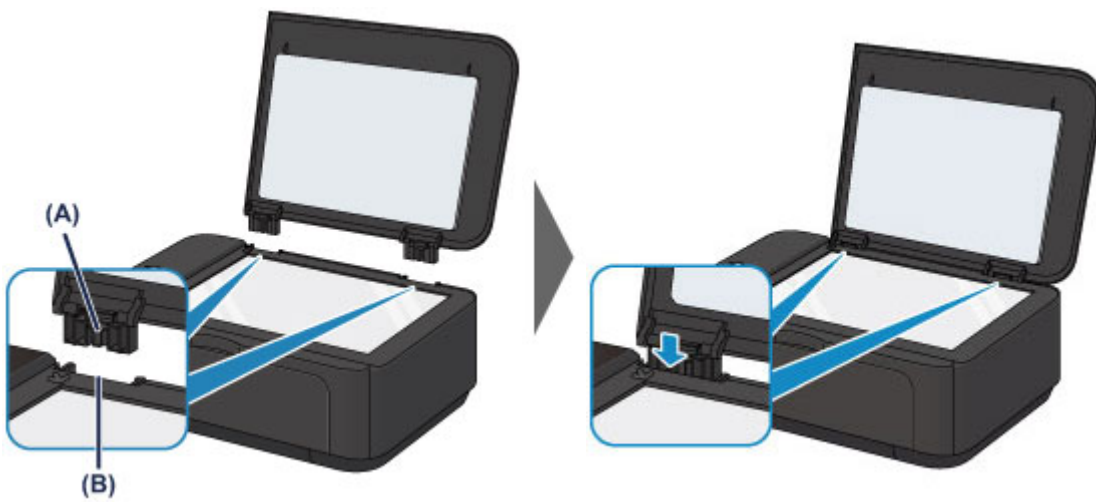

## Replacing a FINE Cartridge

- [Replacing a FINE Cartridge](#)
- [Checking the Ink Status](#)



## Replacing a FINE Cartridge

When remaining ink cautions or errors occur, the ink lamps and the **Alarm** lamp will flash orange to inform you of the error. Count the number of flashes and take appropriate action.

➔ If an Error Occurs

### ➤➤➤ Note

- For information on the compatible FINE cartridge, refer to the printed manual: *Safety and Important Information*.

## Replacing Procedure

When you need to replace a FINE cartridge, follow the procedure below.

➔ Watch the movie

### ➤➤➤ Important

#### Handling FINE cartridge

- Do not touch the electrical contacts **(A)** or print head nozzle **(B)** on a FINE cartridge. The machine may not print properly if you touch them.

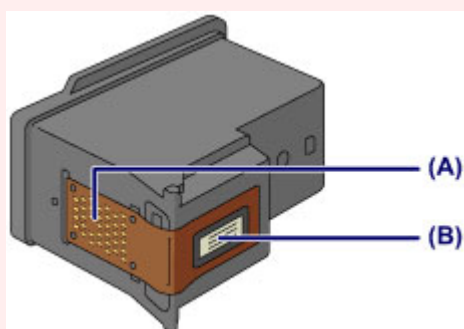

- If you remove a FINE cartridge, replace it immediately. Do not leave the machine with the FINE cartridge removed.
- Use a new FINE cartridge for replacement. Installing a used FINE cartridge may cause the nozzles to clog. Furthermore, with such a FINE cartridge, the machine will not be able to inform you when to replace the FINE cartridge properly.
- Once a FINE cartridge has been installed, do not remove it from the machine and leave it out in the open. This will cause the FINE cartridge to dry out, and the machine may not operate properly when it is reinstalled. To maintain optimal printing quality, use a FINE cartridge within six months of first use.

### ➤➤➤ Note

- If a FINE cartridge runs out of ink, you can print with either color or black FINE cartridge, in whichever ink remains, only for a while. However the print quality may be reduced compared to when printing with both cartridges. We recommend to use a new FINE cartridge in order to obtain optimum qualities. Even when printing with one ink only, print with leaving the empty FINE cartridge installed. If either of the color FINE cartridge or black FINE cartridge is not installed, an error occurs and the machine cannot print. For information on how to configure this setting, see [Setting the Ink Cartridge to be Used](#).
  - Color ink may be consumed even when printing a black-and-white document or when black-and-white printing is specified. Both color ink and black ink are also consumed in the standard cleaning and deep cleaning of the print head, which may be necessary to maintain the performance of the machine. When ink runs out, replace the FINE cartridge immediately with a new one.
- ➔ [Useful Information about Ink](#)

1. Make sure that the power is turned on, open the front cover **(C)**, then open the paper output tray **(D)**.

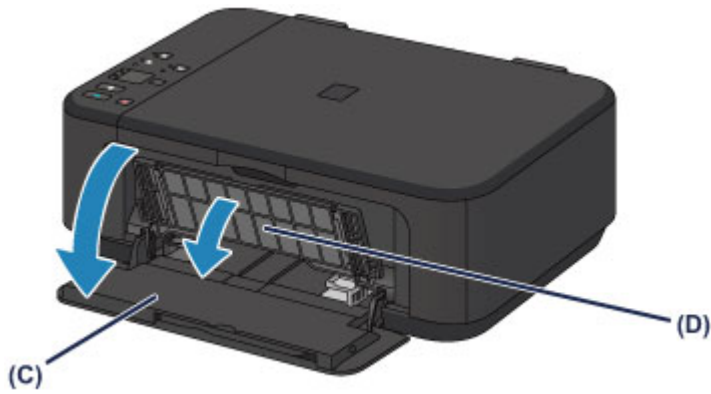

**2. Open the paper output cover (E).**

When the FINE cartridge holder moves to the replacement position, the head cover (F) OPENS AUTOMATICALLY.

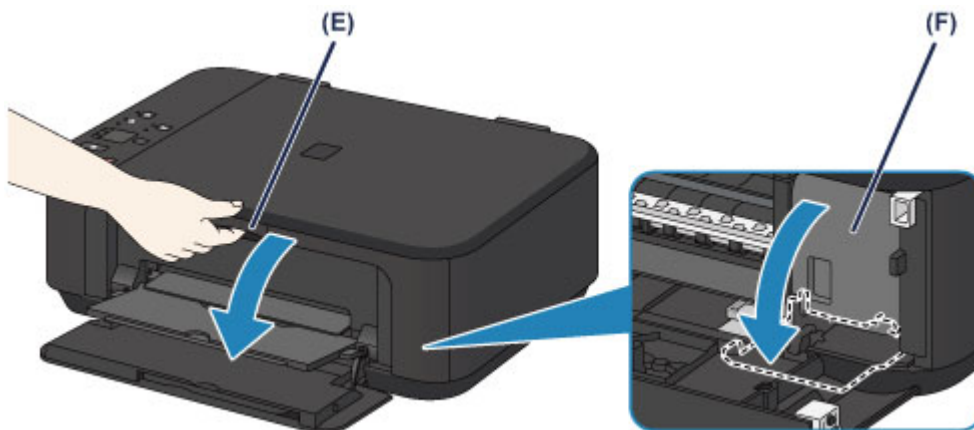

**⚠ Caution**

- Do not hold the FINE cartridge holder to stop or move it forcibly. Do not touch the FINE cartridge holder until it stops completely.

**➤➤ Important**

- The head cover will open automatically after you open the paper output cover.  
If you have closed the head cover while replacing a FINE cartridge, close the paper output cover, then open it again.  
Trying to force open the head cover with your hand may cause the machine to malfunction.
- Do not touch the metallic parts or other parts inside the machine.
- If the paper output cover is left open for more than 10 minutes, the FINE cartridge holder moves to the far right and the **Alarm** lamp lights. In this case, close the paper output cover, then open it again.

**3. Remove the empty FINE cartridge.**

**(1)** Push down the ink cartridge lock lever until it clicks.

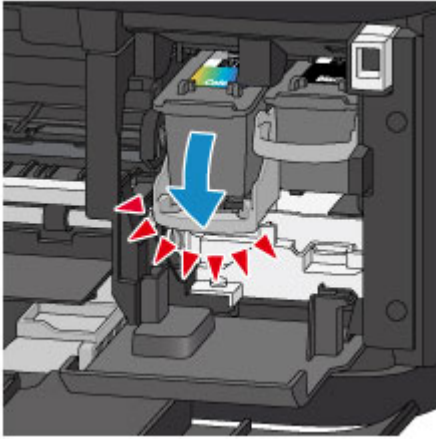

(2) Remove the FINE cartridge.

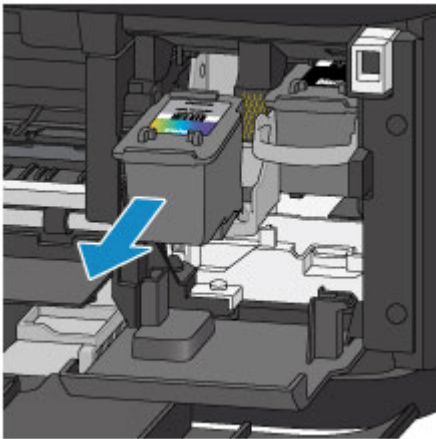

**Important**

- Handle the FINE cartridge carefully to avoid staining of clothing or the surrounding area.
- Discard the empty FINE cartridge according to the local laws and regulations regarding disposal of consumables.

4. Prepare a new FINE cartridge.

(1) Take a new FINE cartridge out of its package and remove the protective tape (G) gently.

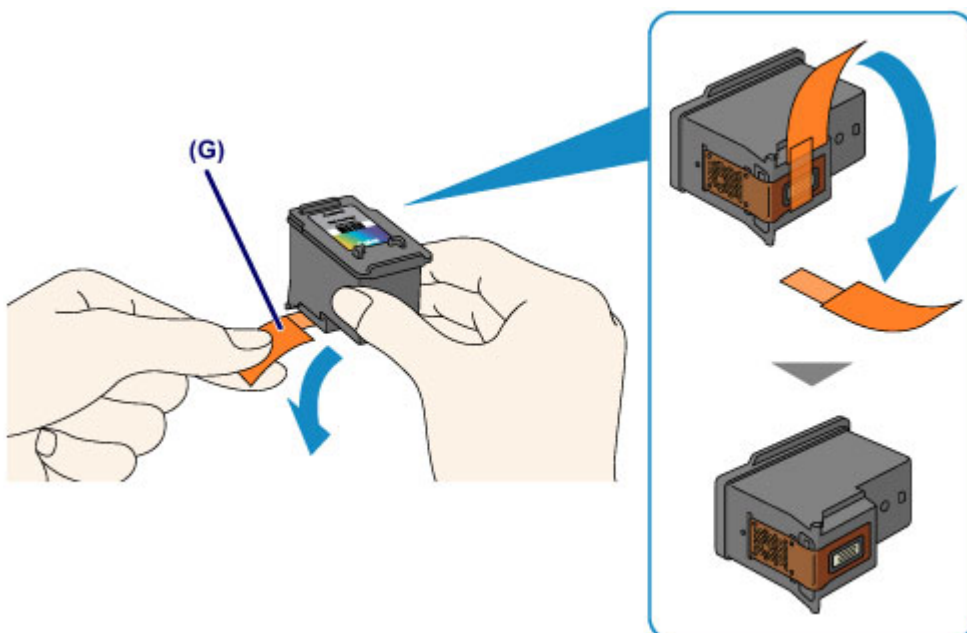

## ▶▶▶ Important

- If you shake a FINE cartridge, ink may spill out and stain your hands and the surrounding area. Handle a FINE cartridge carefully.
- Be careful not to stain your hands and the surrounding area with ink on the removed protective tape.
- Do not reattach the protective tape once you have removed it. Discard it according to the local laws and regulations regarding disposal of consumables.
- Do not touch the electrical contacts or print head nozzle on a FINE cartridge. The machine may not print properly if you touch them.

### 5. Install the FINE cartridge.

**(1)** Insert the new FINE cartridge straight into the FINE cartridge holder all the way until it touches the back.

The color FINE cartridge should be installed into the left slot and the black FINE cartridge should be installed into the right slot.

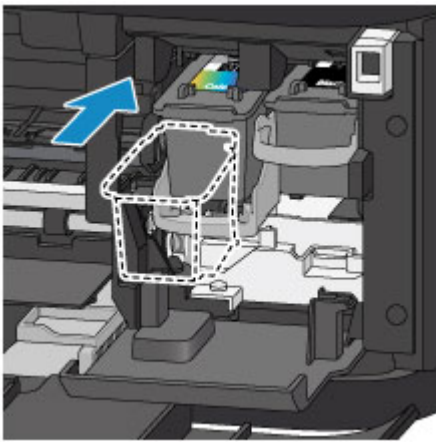

## ▶▶▶ Important

- Insert the FINE cartridge gently so that it does not hit the electrical contacts on the FINE cartridge holder.



**(2)** Push up the ink cartridge lock lever to lock the FINE cartridge into place.

The FINE cartridge is locked into place when the ink cartridge lock lever clicks.

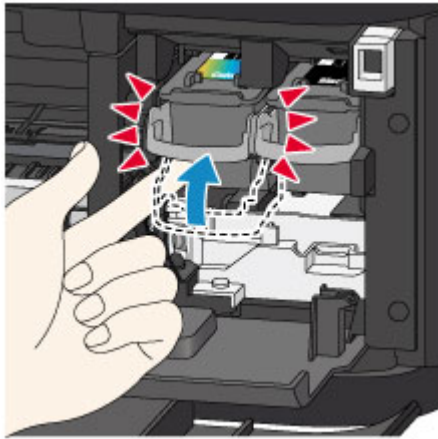

### ▶▶ Important

- Check if the FINE cartridge is installed correctly.

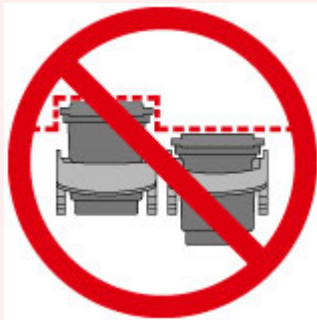

- The machine cannot print unless both the color FINE cartridge and black FINE cartridge are installed. Be sure to install both cartridges.

### 6. Close the paper output cover (H).

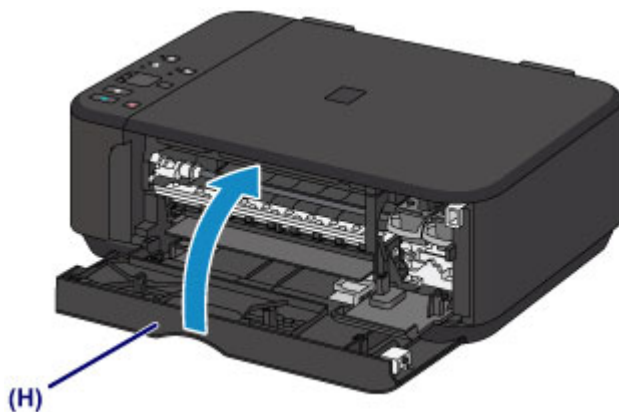

### ▶▶ Note

- If the **Alarm** lamp lights or flashes orange after the paper output cover is closed, take appropriate action.
  - ➡ If an Error Occurs
- When you start printing after replacing the FINE cartridge, the machine starts cleaning the print head automatically. Do not perform any other operations until the machine completes the cleaning of the print head.
- If the print head is out of alignment, as indicated by misaligned printed ruled lines or similar symptoms, adjust the print head position.
  - ➡ [Aligning the Print Head](#)
- The machine may make noise during operation.

## Checking the Ink Status

- [Checking the Ink Status with the Ink Lamps on the Operation Panel](#)

You can also check the ink status on the computer screen.

- [Checking the Ink Status from Your Computer](#)

## Checking the Ink Status with the Ink Lamps on the Operation Panel

### ▶▶▶ Note

- The ink level detector is mounted on the machine to detect the remaining ink level. The machine considers as ink is full when a new FINE cartridge is installed, and then starts to detect a remaining ink level. If you install a used FINE cartridge, the indicated ink level of it may not be correct. In such case, refer to the ink level information only as a guide.
- When remaining ink cautions or errors occur, the ink lamps and the **Alarm** lamp will flash orange to inform you of the error. Count the number of flashes and take appropriate action.
  - ➔ If an Error Occurs

In the copy standby mode, you can check the ink status with the **Color Ink** lamp and **Black Ink** lamp.

\* All the lamps on the operation panel are shown lit in the illustration below for explanatory purposes.

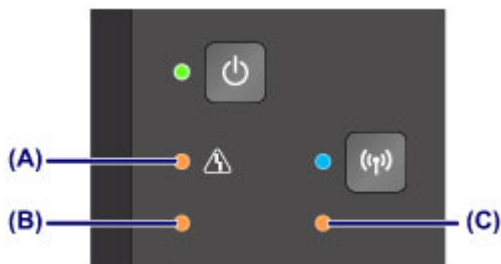

- (A) Alarm lamp
- (B) Color Ink lamp
- (C) Black Ink lamp

### Color Ink lamp or Black Ink lamp lights

The ink is running low. Prepare a new ink cartridge.

### Color Ink lamp or Black Ink lamp flashes, while Alarm lamp flashes

An error has occurred.

➔ If an Error Occurs

\* For some types of errors, the **Alarm** lamp may not flash.

### ▶▶▶ Note

- You can also check the ink status on the computer screen.
  - ➔ Checking the Ink Status from Your Computer

## Maintenance

- ➔ [When Printing Becomes Faint or Colors Are Incorrect](#)
- ➔ [Performing Maintenance from a Computer](#)
- ➔ [Cleaning the Machine](#)



## When Printing Becomes Faint or Colors Are Incorrect

- Maintenance Procedure
- Printing the Nozzle Check Pattern
- Examining the Nozzle Check Pattern
- Cleaning the Print Head
- Cleaning the Print Head Deeply
- Aligning the Print Head

## Maintenance Procedure

If print results are blurred or colors are not printed correctly, the print head nozzle (FINE cartridge) is probably clogged. Follow the procedure below to print the nozzle check pattern, check the print head nozzle condition, then clean the print head.

If printed ruled lines are misaligned or print results are otherwise unsatisfactory, aligning the print head may improve print quality.

### ▶▶▶ Important

- Do not rinse or wipe the FINE cartridge. This can cause trouble with the FINE cartridge.

### ▶▶▶ Note

#### Before performing maintenance

- Check if ink remains in the FINE cartridge.
    - ➔ [Checking the Ink Status with the Ink Lamps on the Operation Panel](#)
  - Check if the FINE cartridge is installed correctly.
    - ➔ [Replacing Procedure](#)
- Also check if the protective tape on the bottom of the FINE cartridge is removed.

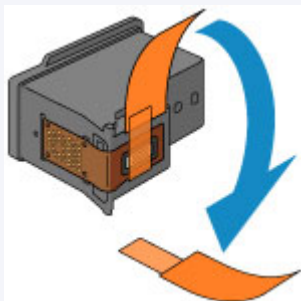

- If the **Alarm** lamp lights or flashes orange, see [If an Error Occurs](#).
- Increasing the print quality in the printer driver settings may improve the print result.
  - ➔ [Changing the Print Quality and Correcting Image Data](#)

## When the Print Results Are Blurred or Uneven:

### Step 1

#### Print the nozzle check pattern.

- From the machine
  - ➔ [Printing the Nozzle Check Pattern](#)
- From the computer
  - ➔ [Use Your Computer to Print a Nozzle Check Pattern](#)

#### Examine the nozzle check pattern.

- ➔ [Examining the Nozzle Check Pattern](#)

If there are missing lines or horizontal white streaks in the pattern:

### Step 2

#### Clean the print head.

- From the machine
  - ➔ [Cleaning the Print Head](#)
- From the computer
  - ➔ [Cleaning the Print Heads from Your Computer](#)

After cleaning the print head, print and examine the nozzle check pattern.

If the problem is not resolved after cleaning the print head twice:



### Step 3

#### Clean the print head deeply.

From the machine

➡ [Cleaning the Print Head Deeply](#)

From the computer

➡ [Cleaning the Print Heads from Your Computer](#)

If the problem is not resolved, turn off the power and clean the print head deeply again after 24 hours.

If the problem is still not resolved:



### Step 4

#### Replace a FINE cartridge.

➡ [Replacing a FINE Cartridge](#)

#### ▶▶▶ Note

- If the problem is still not resolved after replacing the FINE cartridge, contact the service center.

### When the Print Results Are Not Even such as the Ruled Lines Are Misaligned:

#### Align the print head.

From the machine

➡ [Aligning the Print Head](#)

From the computer

➡ [Aligning the Print Head Position Automatically from Your Computer](#)

## Printing the Nozzle Check Pattern

Print the nozzle check pattern to determine whether the ink ejects properly from the print head nozzle.

➔ Watch the movie

### ▶▶▶ Note

- If the remaining ink level is low, the nozzle check pattern will not be printed correctly. Replace the FINE cartridge whose ink is low.

➔ [Replacing a FINE Cartridge](#)

### You need to prepare: a sheet of A4 or Letter-sized plain paper

1. Make sure that the power is turned on.
2. Load a sheet of A4 or Letter-sized plain paper in the front tray.
3. Open the output tray extension, open the paper output tray, then extend the paper output support.
4. Hold down the **Stop** button until the **Alarm** lamp flashes orange once, then release it immediately.

The nozzle check pattern will be printed.

Do not perform any other operations until the machine completes the printing of the nozzle check pattern.

5. Examine the nozzle check pattern.

➔ [Examining the Nozzle Check Pattern](#)

## Examining the Nozzle Check Pattern

Examine the nozzle check pattern, and clean the print head if necessary.

1. Check if there are missing lines in the pattern **(A)** or horizontal white streaks in the pattern **(B)**.

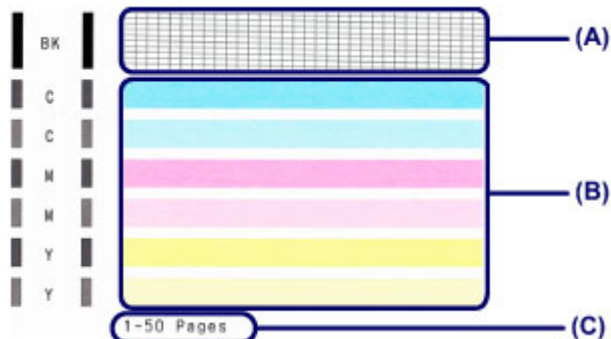

**(C)** Number of sheets printed so far

**If there are missing lines in the pattern (A):**

Cleaning the print head is required.

➡ [Cleaning the Print Head](#)



**(D)** Good

**(E)** Bad (lines are missing)

**If there are horizontal white streaks in the pattern (B):**

Cleaning the print head is required.

➡ [Cleaning the Print Head](#)



**(F)** Good

**(G)** Bad (horizontal white streaks are present)

### ➡➡➡ Note

- The total number of sheets printed so far is shown in increments of 50 sheets on the printout of the nozzle check pattern.

## Cleaning the Print Head

Clean the print head if lines are missing or if horizontal white streaks are present in the printed nozzle check pattern. Cleaning unclogs the nozzles and restores the print head condition. Cleaning the print head consumes ink, so clean the print head only when necessary.

1. Make sure that the power is turned on.
2. Hold down the **Stop** button until the **Alarm** lamp flashes orange twice, then release it immediately.

The machine starts cleaning the print head.

The cleaning will be complete when the **ON** lamp lights green after flashing.

Do not perform any other operations until the machine completes the cleaning of the print head. This takes about 1 to 2 minutes.

3. Check the print head condition.

To check the print head condition, print the nozzle check pattern.

➔ [Printing the Nozzle Check Pattern](#)

### »» Note

- If the problem is not resolved after cleaning the print head twice, clean the print head deeply.

➔ [Cleaning the Print Head Deeply](#)

## Cleaning the Print Head Deeply

If print quality does not improve by the standard cleaning of the print head, clean the print head deeply. Cleaning the print head deeply consumes more ink than the standard cleaning of the print head, so clean the print head deeply only when necessary.

1. Make sure that the power is turned on.
2. Hold down the **Stop** button until the **Alarm** lamp flashes orange three times, then release it immediately.

The machine starts cleaning the print head deeply.

The cleaning will be complete when the **ON** lamp lights green after flashing.

Do not perform any other operations until the machine completes the deep cleaning of the print head. This takes about 1 to 2 minutes.

3. Check the print head condition.

To check the print head condition, print the nozzle check pattern.

➡ [Printing the Nozzle Check Pattern](#)

If the problem is not resolved, turn off the power and clean the print head deeply again after 24 hours.

If the problem is still not resolved, replace the FINE cartridge with a new one.

➡ [Replacing a FINE Cartridge](#)

If the problem is still not resolved after replacing the FINE cartridge, contact the service center.

## Aligning the Print Head

If printed ruled lines are misaligned or print results are otherwise unsatisfactory, adjust the print head position.

### ►►► Note

- If the remaining ink level is low, the print head alignment sheet will not be printed correctly. Replace the FINE cartridge whose ink is low.  
➔ [Replacing a FINE Cartridge](#)

### You need to prepare: a sheet of A4 or Letter-sized plain paper (including recycled paper)\*

\* Be sure to use paper that is white and clean on both sides.

1. Make sure that the power is turned on.
2. Load a sheet of A4 or Letter-sized plain paper in the front tray.
3. Open the output tray extension, open the paper output tray, then extend the paper output support.
4. Hold down the **Stop** button until the **Alarm** lamp flashes orange four times, then release it immediately.

The print head alignment sheet will be printed.

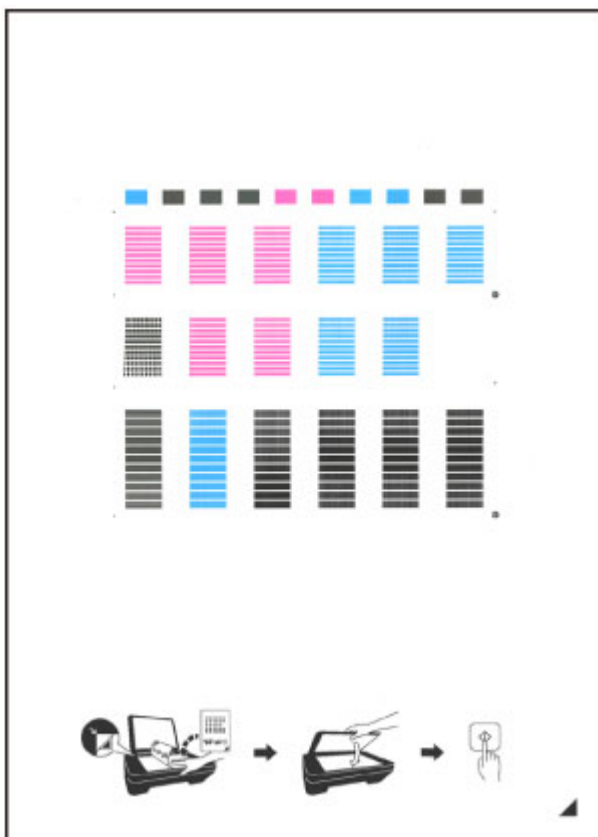

### ►►► Important

- Do not touch any printed part on the print head alignment sheet.
- Be careful not to get the print head alignment sheet dirty. If the sheet is stained or wrinkled, it may not be scanned properly.



- If the print head alignment sheet was not printed correctly, press the **Stop** button, then redo this procedure from the beginning.

## 5. Scan the print head alignment sheet to adjust the print head position.

### (1) Load the print head alignment sheet on the platen glass.

Load the print head alignment sheet WITH THE PRINTED SIDE FACING DOWN and align the mark ▲ on the bottom right corner of the sheet with the alignment mark ▼.

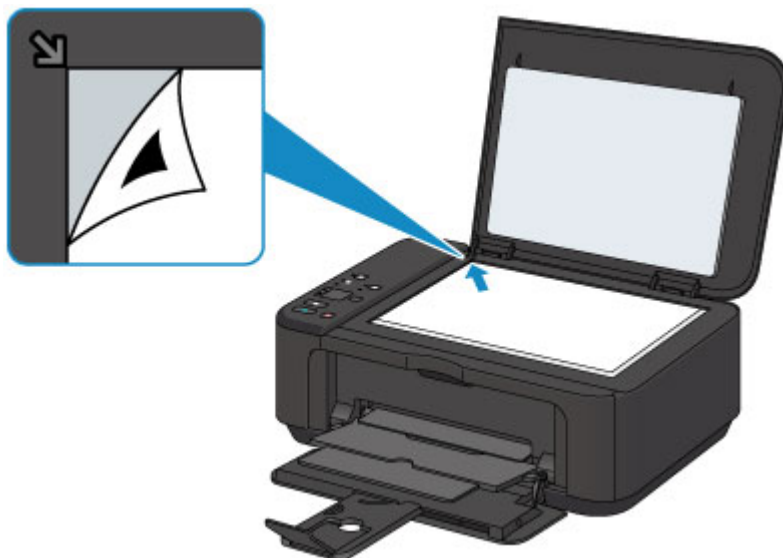

### (2) Close the document cover gently, then press the **Color** button or the **Black** button.

The machine starts scanning the print head alignment sheet, and the print head position will be adjusted automatically.

The print head position adjustment will be complete when the **ON** lamp lights green after flashing.

Remove the print head alignment sheet on the platen glass.

#### ►►► Important

- Do not open the document cover or move the print head alignment sheet on the platen glass until adjusting the print head position is complete.
- If adjusting the print head position has failed, the **Alarm** lamp flashes orange. Press the **Stop** button to release the error, then take appropriate action.
  - ➔ If an Error Occurs

#### ►►► Note

- If the print results are still not satisfactory after adjusting the print head position as described above, adjust the print head position manually from the computer.
  - ➔ [Aligning the Print Head Position from Your Computer](#)
- To print and check the current head position adjustment values, hold down the **Stop** button until the **Alarm** lamp flashes orange six times, then release it immediately.

## Performing Maintenance from a Computer

- [Cleaning the Print Heads from Your Computer](#)
- [Cleaning the Paper Feed Rollers from Your Computer](#)
- [Aligning the Print Head](#)
- [Aligning the Print Head Position Automatically from Your Computer](#)
- [Aligning the Print Head Position from Your Computer](#)
- [Use Your Computer to Print a Nozzle Check Pattern](#)
- [Cleaning Inside the Machine](#)

## Cleaning the Print Heads from Your Computer

The print head cleaning function allows you to clear up clogged print head nozzle. Perform print head cleaning if printing is faint or a specific color fails to print, even though there is enough ink.

The procedure for cleaning the print head is as follows:



### Cleaning

1. Open the printer driver setup window

2. Click **Cleaning** on the **Maintenance** tab

When the **Print Head Cleaning** dialog box opens, select the ink group for which cleaning is to be performed. Click **Initial Check Items** to display the items you need to check before performing cleaning.

3. Execute cleaning

Make sure that the machine is on and then click **Execute**.

Print head cleaning starts.

4. Complete cleaning

The **Nozzle Check** dialog box opens after the confirmation message.

5. Check the results

To check whether the print quality has improved, click **Print Check Pattern**. To cancel the check process, click **Cancel**.

If cleaning the head once does not resolve the print head problem, clean it once more.

### ►►► Important

- **Cleaning** consumes a small amount of ink.

Cleaning the print head frequently will rapidly deplete your printer's ink supply. Consequently, perform cleaning only when necessary.



### Deep Cleaning

**Deep Cleaning** is more thorough than cleaning. Perform deep cleaning when two **Cleaning** attempts do not resolve the print head problem.

1. Open the printer driver setup window

2. Click **Deep Cleaning** on the **Maintenance** tab

When the **Deep Cleaning** dialog box opens, select the ink group for which deep cleaning is to be performed. Click **Initial Check Items** to display the items you need to check before performing deep cleaning.

3. Execute deep cleaning

Make sure that the machine is on and then click **Execute**.

Click **OK** when the confirmation message appears.

Print head deep cleaning starts.

#### 4. Complete deep cleaning

The **Nozzle Check** dialog box opens after the confirmation message.

#### 5. Check the results

To check whether the print quality has improved, click **Print Check Pattern**. To cancel the check process, click **Cancel**.

### »» Important

- **Deep Cleaning** consumes a larger amount of ink than **Cleaning**.

Cleaning the print head frequently will rapidly deplete your printer's ink supply. Consequently, perform cleaning only when necessary.

### »» Note

- If there is no sign of improvement after **Deep Cleaning**, switch off the machine, wait 24 hours, and then perform **Deep Cleaning** again. If there is still no sign of improvement, see "Ink Is Not Ejected."

### Related Topic

- [Use Your Computer to Print a Nozzle Check Pattern](#)

## Cleaning the Paper Feed Rollers from Your Computer

Cleans the paper feed rollers. Perform feed roller cleaning when there are paper particles sticking to the paper feed rollers and paper is not fed properly.

The procedure for performing the feed roller cleaning is as follows:



### Roller Cleaning

1. Prepare the machine

Remove all sheets of paper from the front tray.

2. Open the printer driver setup window

3. Click **Roller Cleaning** on the **Maintenance** tab

The confirmation message appears.

4. Execute paper feed roller cleaning

Make sure that the machine is on and then click **OK**.

Paper feed roller cleaning starts.

5. Complete paper feed roller cleaning

After the rollers have stopped, follow the message instructions and load one sheet of plain paper or a cleaning sheet available on the market into the front tray. Then click **OK**.

Paper will be ejected and feed roller cleaning will be completed.

## Aligning the Print Head

When you perform head position adjustment, errors in the print head adjustment position are corrected and conditions such as color and line streaking are improved.

If the print results appear uneven because of line shifts or other conditions, adjust the position of the print head.

On this machine, you can adjust the print head either [automatically](#) or [manually](#).

## Aligning the Print Head Position from Your Computer

Print head alignment corrects the installation positions of the print head and improves deviated colors and lines.

This machine supports two head alignment methods: [automatic head alignment](#) and manual head alignment.

The procedure for performing manual print head alignment is as follows:



### Print Head Alignment

1. Open the printer driver setup window
2. Click **Custom Settings** on the **Maintenance** tab  
The **Custom Settings** dialog box opens.
3. Switch head alignment to manual  
Check the **Align heads manually** check box.
4. Apply the settings  
Click **OK** and when the confirmation message appears, click **OK**.
5. Click **Print Head Alignment** on the **Maintenance** tab  
The **Start Print Head Alignment** dialog box opens.
6. Load paper in the machine  
Load three sheets of A4 size or Letter size plain paper into the front tray.
7. Execute head alignment  
Make sure that the machine is on and click **Align Print Head**.  
Follow the instruction in the message.
8. Check the printed pattern  
Enter the numbers of the patterns with the least amount of streaks in the associated boxes.  
Even if the patterns with the least amount of streaks are clicked in the preview window, their numbers are automatically entered in the associated boxes.

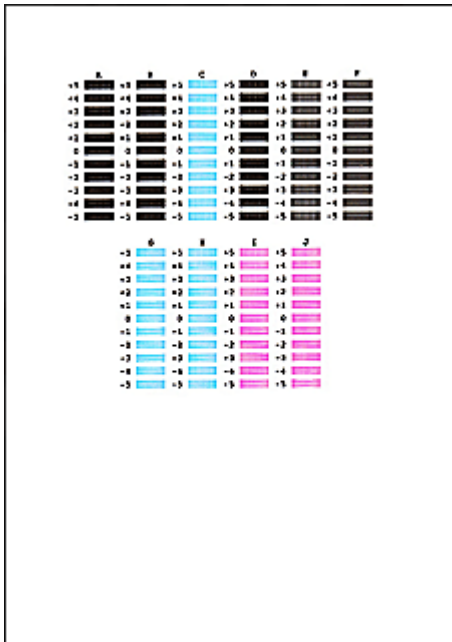

When you have entered all the necessary values, click **OK**.

**➤➤➤ Note**

- If it is difficult to pick the best pattern, pick the setting that produces the least noticeable vertical streaks.



(A)



(B)

(A) Least noticeable vertical streaks

(B) Most noticeable vertical streaks

- If it is difficult to pick the best pattern, pick the setting that produces the least noticeable horizontal streaks.



(A)



(B)

(A) Least noticeable horizontal streaks

(B) Most noticeable horizontal streaks

**9. Confirm the displayed message and click **OK****

The second pattern is printed.

**10. Check the printed pattern**

Enter the numbers of the patterns with the least amount of streaks in the associated boxes.

Even if the patterns with the least amount of streaks are clicked in the preview window, their numbers are automatically entered in the associated boxes.



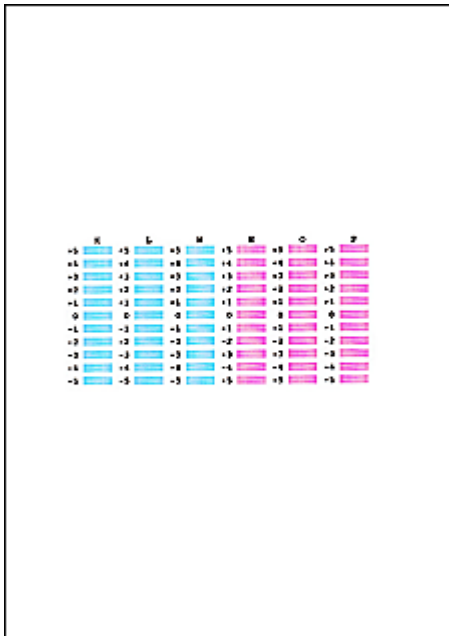

When you have entered all the necessary values, click **OK**.

**»» Note**

- If it is difficult to pick the best pattern, pick the setting that produces the least noticeable vertical streaks.



(A)



(B)

(A) Least noticeable vertical streaks

(B) Most noticeable vertical streaks

**11. Confirm the displayed message and click **OK****

The third pattern is printed.

**12. Check the printed pattern**

Enter the numbers of the patterns with the least noticeable horizontal stripes in the associated boxes.

Even if the patterns with the least noticeable horizontal stripes are clicked in the preview window, their numbers are automatically entered in the associated boxes.

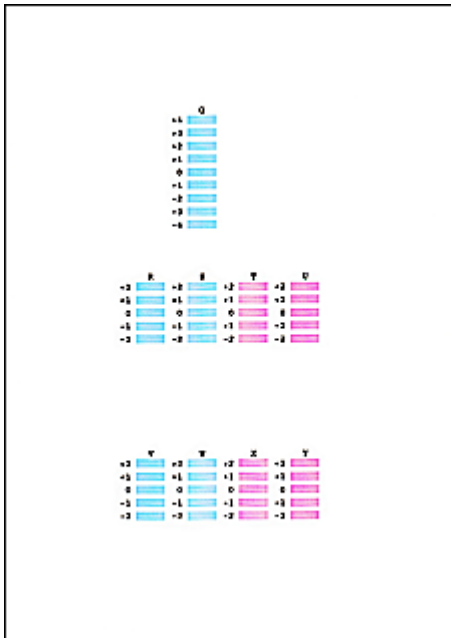

When you have entered all the necessary values, click **OK**.

**►►► Note**

- If it is difficult to pick the best pattern, pick the setting that produces the least noticeable horizontal stripes.



(A)

(A) Least noticeable horizontal stripes



(B)

(B) Most noticeable horizontal stripes

**►►► Note**

- To print and check the current setting, open the **Start Print Head Alignment** dialog box, and click **Print Alignment Value**.

# Aligning the Print Head Position Automatically from Your Computer

Print head alignment corrects the installation positions of the print head and improves deviated colors and lines.

This machine supports two head alignment methods: automatic head alignment and manual head alignment. Normally, the machine is set for automatic head alignment. If the printing results of automatic print head alignment are not satisfactory, [perform manual head alignment](#).

The procedure for performing automatic print head alignment is as follows:

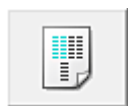

## Print Head Alignment

1. Open the printer driver setup window
2. Click **Print Head Alignment** on the **Maintenance** tab

The **Start Print Head Alignment** dialog box opens.

3. Load paper in the machine

Load one sheet of A4 size or Letter size plain paper into the front tray.

### ▶▶▶ Note

- The number of sheets to be used differs when you select the manual head alignment.

4. Print head alignment pattern printing

Make sure that the machine is on and click **Align Print Head**.

The adjustment pattern is printed.

### ▶▶▶ Important

- Do not open the paper output cover while printing is in progress.

5. Adjustment pattern scanning

After the adjustment pattern is printed, a message is displayed.

As instructed in the message, load the adjustment pattern onto the platen, and press the **Start** button on the machine.

Print head alignment starts.

### ▶▶▶ Note

- To print and check the current setting, open the **Start Print Head Alignment** dialog box, and click **Print Alignment Value**.

## Use Your Computer to Print a Nozzle Check Pattern

The nozzle check function allows you to check whether the print head is working properly by printing a nozzle check pattern. Print the pattern if printing becomes faint, or if a specific color fails to print.

The procedure for printing a nozzle check pattern is as follows:



### Nozzle Check

1. Open the printer driver setup window

2. Click **Nozzle Check** on the **Maintenance** tab

The **Nozzle Check** dialog box opens.

Click **Initial Check Items** to display the items that you need to check before printing the nozzle check pattern.

3. Load paper in the machine

Load one sheet of A4 size or Letter size plain paper into the front tray.

4. Print a nozzle check pattern

Make sure that the machine is on and click **Print Check Pattern**.

Printing of the nozzle check pattern begins.

Click **OK** when the confirmation message appears.

The **Pattern Check** dialog box opens.

5. Check the print result

Check the print result. When the print result is normal, click **Exit**.

If the print result is smudged or if there are any unprinted sections, click **Cleaning** to clean the print head.

### Related Topic

- [Cleaning the Print Heads from Your Computer](#)

## Cleaning Inside the Machine

Perform bottom plate cleaning before you execute duplex printing to prevent smudges on the back side of the paper. Also perform bottom plate cleaning if ink smudges caused by something other than print data appear on the printed page.

The procedure for performing bottom plate cleaning is as follows:



### Bottom Plate Cleaning

1. Open the printer driver setup window
2. Click **Bottom Plate Cleaning** on the **Maintenance** tab

The **Bottom Plate Cleaning** dialog box opens.

3. **Load paper** in the machine

As instructed in the dialog box, fold the A4 size or Letter size plain paper in half horizontally, and then unfold the sheet.

Fold one side of the paper in another half, aligning the edge with the center crease, then unfold the paper.

With the ridges of the creases facing up, load the paper into the front tray, so that the edge of the half with no crease faces away from you.

4. Perform the bottom plate cleaning

Make sure that the machine is on and then click **Execute**.

Bottom plate cleaning starts.

## Cleaning the Machine

- Cleaning the Exterior of the Machine
- Cleaning the Platen Glass and Document Cover
- Cleaning the Paper Feed Roller
- Cleaning the Inside of the Machine (Bottom Plate Cleaning)
- Cleaning the Protrusions inside the Machine

## Cleaning the Exterior of the Machine

Be sure to use a soft and dry cloth such as eyeglasses cleaning cloth and wipe off dirt on the surface gently. Smooth out wrinkles on the cloth if necessary before cleaning.

### Important

- Be sure to turn off the power and disconnect the power plug before cleaning the machine.
- Do not use tissue paper, paper towels, rough-textured cloth, or similar materials for cleaning so as not to scratch the surface. Be sure to use a soft and dry cloth.
- Never use volatile liquids such as thinners, benzene, acetone, or any other chemical cleaner to clean the machine, as this may cause a malfunction or damage the surface of the machine.

## Cleaning the Platen Glass and Document Cover

### ►►► Important

- Be sure to turn off the power and disconnect the power plug before cleaning the machine.
- Do not use tissue paper, paper towels, rough-textured cloth, or similar materials for cleaning so as not to scratch the surface. Be sure to use a soft and dry cloth.
- Never use volatile liquids such as thinners, benzene, acetone, or any other chemical cleaner to clean the machine, as this may cause a malfunction or damage the surface of the machine.

With a soft, clean, lint-free and dry cloth, wipe the platen glass **(A)** and the inner side of the document cover (white sheet) **(B)** gently. Make sure not to leave any residue, especially on the glass surface.

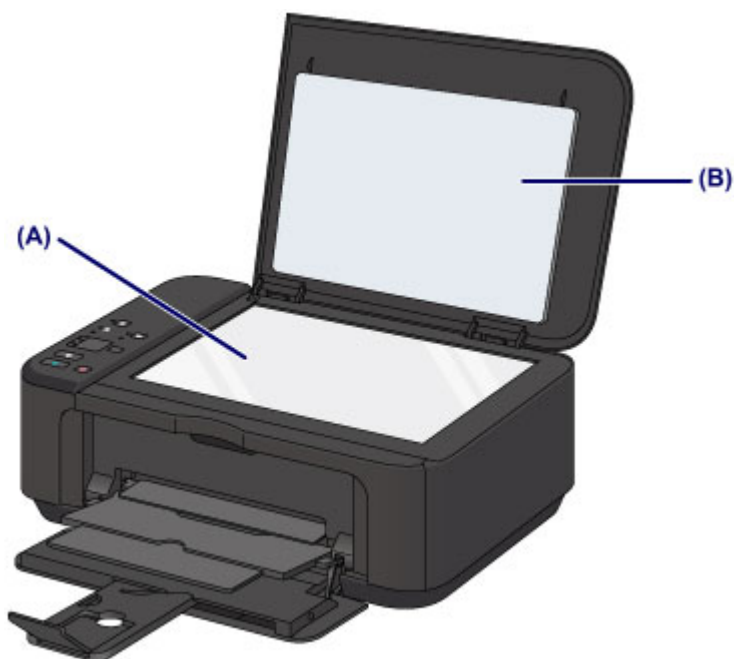

### ►►► Important

- The inner side of the document cover (white sheet) **(B)** is easily damaged, so wipe it gently.



## Cleaning the Paper Feed Roller

If the paper feed roller is dirty or paper powder is attached to it, paper may not be fed properly.

In this case, clean the paper feed roller. Cleaning will wear out the paper feed roller, so perform this only when necessary.

**You need to prepare: a sheet of A4 or Letter-sized plain paper or commercially available cleaning sheet**

1. Make sure that the power is turned on and remove any paper from the front tray.
2. Clean the paper feed roller without paper.
  - (1) Hold down the **Stop** button until the **Alarm** lamp flashes orange seven times, then release it immediately.  
The paper feed roller will rotate as it is cleaned.
3. Clean the paper feed roller with paper.
  - (1) Make sure that the paper feed roller has stopped rotating, load a sheet of A4 or Letter-sized plain paper or commercially available cleaning sheet in the front tray.
  - (2) Open the output tray extension, open the paper output tray, then extend the paper output support.
  - (3) Hold down the **Stop** button until the **Alarm** lamp flashes orange seven times, then release it immediately.  
The machine starts cleaning. The cleaning will be complete when the paper is ejected.

If the problem is not resolved after cleaning the paper feed roller, contact the service center.

## Cleaning the Inside of the Machine (Bottom Plate Cleaning)

Remove stains from the inside of the machine. If the inside of the machine becomes dirty, printed paper may get dirty, so we recommend performing cleaning regularly.

**You need to prepare: a sheet of A4 or Letter-sized plain paper\***

\* Be sure to use a new piece of paper.

1. Make sure that the power is turned on and remove any paper from the front tray.
2. Prepare paper.
  - (1) Fold a single sheet of A4 or Letter-sized plain paper in half widthwise, then unfold the paper.
  - (2) Fold one side of the opened paper in another half, aligning the edge with the center crease, then unfold the paper.

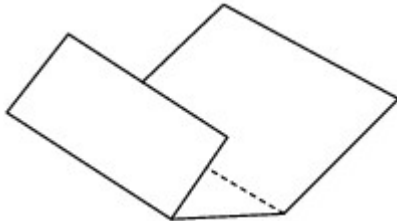

- (3) Load only this sheet of paper in the front tray with the ridges of the creases facing up and the edge of the half with no crease facing away from you.

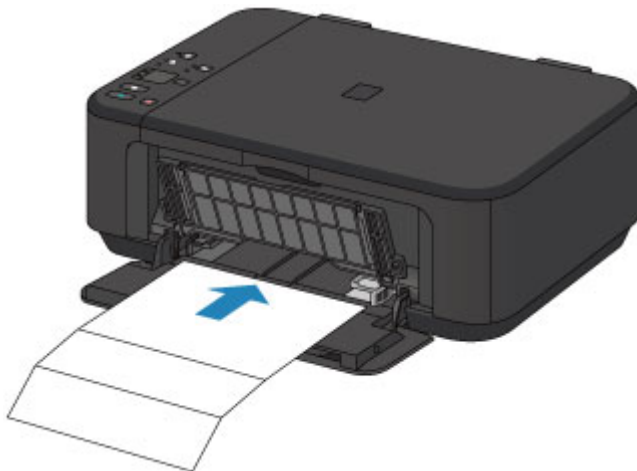

3. Open the output tray extension, open the paper output tray, then extend the paper output support.
4. Clean the inside of the machine.

Hold down the **Stop** button until the **Alarm** lamp flashes orange eight times, then release it immediately.

The paper cleans the inside of the machine as it feeds through the machine.

Check the folded parts of the ejected paper. If they are smudged with ink, perform Bottom Plate Cleaning again.

If the problem is not resolved after performing cleaning again, the protrusions inside the machine may be stained. Clean them according to instructions.

➡ [Cleaning the Protrusions inside the Machine](#)

**»» Note**

- When performing Bottom Plate Cleaning again, be sure to use a new piece of paper.

## Cleaning the Protrusions inside the Machine

### ►► Important

- Be sure to turn off the power and disconnect the power plug before cleaning the machine.

### You need to prepare: cotton swab

If the protrusions inside the machine are stained, wipe off any ink from the protrusions using a cotton swab or the like.

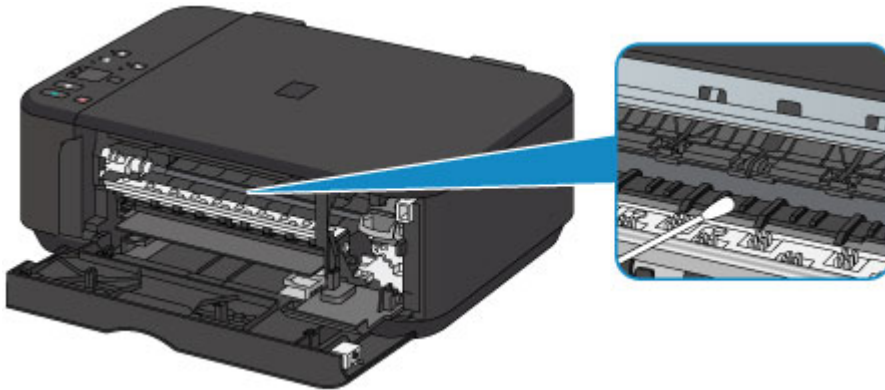

## Changing the Machine Settings

- ➔ [Changing Machine Settings from Your Computer](#)
- ➔ [Changing the Machine Settings Using the Operation Panel](#)

## Changing Machine Settings from Your Computer

- ➔ [Changing the Print Options](#)
- ➔ [Registering a Frequently Used Printing Profile](#)
- ➔ [Setting the Ink Cartridge to be Used](#)
- ➔ [Managing the Machine Power](#)
- ➔ [Reducing the Machine Noise](#)
- ➔ [Changing the Machine Operation Mode](#)

## Changing the Print Options

You can change the detailed print driver settings for print data that is sent from an application software. Specify this option if you encounter print failures such as part of an image data being cut off.

The procedure for changing the print options is as follows:

1. Open the printer driver setup window
2. Click **Print Options...** on the **Page Setup** tab

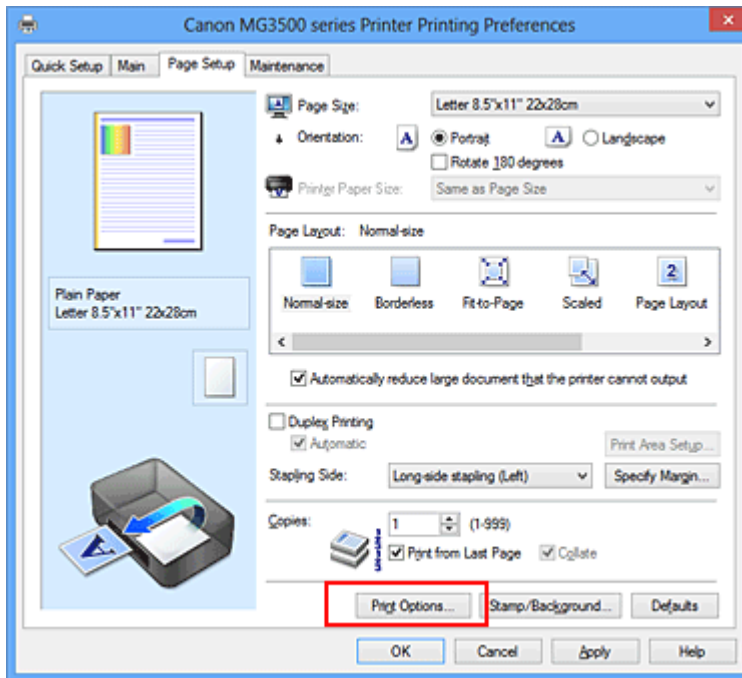

The **Print Options** dialog box opens.

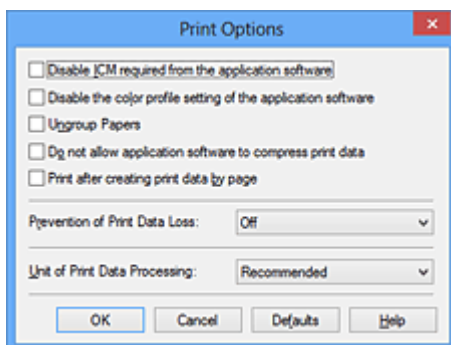

### ►►► Note

- When you use the XPS printer driver, the functions available to you are different.

3. Change the individual settings

If necessary, change the setting of each item, and then click **OK**.

The **Page Setup** tab is displayed again.

## Registering a Frequently Used Printing Profile

You can register the frequently used printing profile to **Commonly Used Settings** on the **Quick Setup** tab. Unnecessary printing profiles can be deleted at any time.

The procedure for registering a printing profile is as follows:

### Registering a Printing Profile

1. Open the printer driver setup window

2. Set the necessary items

From **Commonly Used Settings** on the **Quick Setup** tab, select the printing profile to be used and if necessary, change the settings after **Additional Features**.

You can also register necessary items on the **Main** and **Page Setup** tabs.

3. Click **Save...**

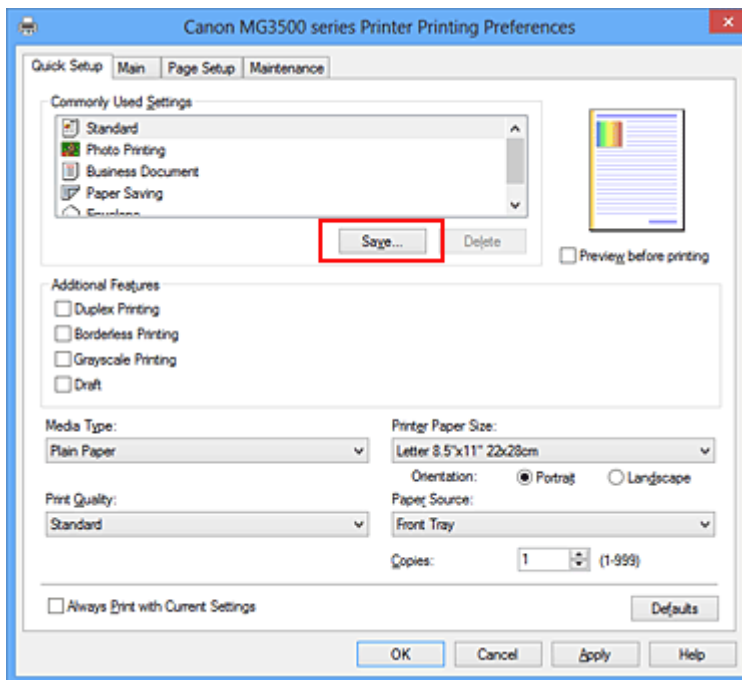

The **Save Commonly Used Settings** dialog box opens.

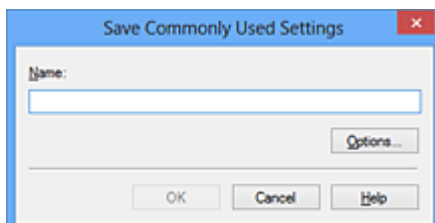

4. Save the settings

Enter a name in the **Name** field. If necessary, click **Options...**, set the items, and then click **OK**.

In the **Save Commonly Used Settings** dialog box, click **OK** to save the print settings and return to the **Quick Setup** tab.

The name and icon are displayed in **Commonly Used Settings**.



## »» Important

---

- To save the page size, orientation, and number of copies that was set in each sheet, click **Options...**, and check each item.

## »» Note

---

- When you install the printer driver again or upgrade the version of the printer driver, the print settings you registered will be deleted from **Commonly Used Settings**.  
Registered print settings cannot be saved and preserved. If a profile is deleted, register the print settings again.

## Deleting Unnecessary Printing Profile

### 1. Select the printing profile to be deleted

Select the printing profile you want to delete from the **Commonly Used Settings** list on the **Quick Setup** tab.

### 2. Delete the printing profile

Click **Delete**. When the confirmation message appears, click **OK**.

The selected printing profile is deleted from the **Commonly Used Settings** list.

## »» Note

---

- Printing profiles that are registered in the initial settings cannot be deleted.

## Setting the Ink Cartridge to be Used

This feature enables you to specify the most appropriate FINE cartridge among installed cartridges according to an intended use.

When one of the FINE cartridges becomes empty and cannot be replaced immediately by a new one, you can specify the other FINE cartridge that still has ink and continue printing.

The procedure for specifying the FINE cartridge is as follows:



### Ink Cartridge Settings

1. Open the printer driver setup window
2. Click **Ink Cartridge Settings** on the **Maintenance** tab

The **Ink Cartridge Settings** dialog box appears.

3. Select the FINE cartridge to be used

Select the FINE cartridge to be used for printing and click **OK**.

The specified FINE cartridge will be used from the next printing.

### ▶▶ Important

- When the following settings are specified, **Black Only** does not function because the machine uses the color FINE cartridge to print documents.
  - Other than **Plain Paper**, **Envelope**, **Hagaki A**, or **Hagaki** is selected for **Media Type** on the **Main** tab
  - **Borderless** is selected from the **Page Layout** list on the **Page Setup** tab
- Do not detach the FINE cartridge that is not in use. Printing cannot be performed while either FINE cartridge is detached.

## Managing the Machine Power

This function allows you to manage the machine power from the printer driver.

The procedure for managing the machine power is as follows:



### Power Off

The **Power Off** function turns off the machine. When you use this function, you will not be able to turn the machine on from the printer driver.

1. Open the printer driver setup window

2. Execute power off

Click **Power Off** on the **Maintenance** tab. When the confirmation message appears, click **OK**.

The machine power switches off, and the **Maintenance** tab is displayed again.



### Auto Power

**Auto Power** allows you to set **Auto Power On** and **Auto Power Off**.

The **Auto Power On** function automatically turns on the machine when data is received.

The **Auto Power Off** function automatically turns off the machine when there are no operations from the printer driver or the machine for a specified period of time.

1. Open the printer driver setup window

2. Make sure that the machine is on and then click **Auto Power** on the **Maintenance** tab

The **Auto Power Settings** dialog box opens.

#### ▶▶▶ Note

- If the machine is off or if communication between the machine and the computer is disabled, an error message may appear because the computer cannot collect the machine status. If this happens, click **OK** to display the most recent settings specified on your computer.

3. If necessary, complete the following settings:

#### **Auto Power On**

Specifying **Enable** from the list will turn the machine on upon receipt of print data.

#### **Auto Power Off**

Specify the time from the list. When this time lapses without any operations from the printer driver or the machine, the machine is turned off automatically.

4. Apply the settings

Click **OK**. When the confirmation message appears, click **OK**.

The **Maintenance** tab is displayed again.

The auto power on/off function is enabled hereafter. When you want to disable this function, select **Disable** from the list according to the same procedure.

### ▶▶▶ Note

- When the machine is turned off, the status monitor message varies depending on the **Auto Power On** setting. When the setting is **Enable**, "Printer is standing by" is displayed. When the setting is **Disable**, "Printer is offline" is displayed.

### ▶▶▶ Important

- If you connect this machine to a network and use it, you can set **Auto Power Off** but the power will not switch off automatically.

## Reducing the Machine Noise

The silent function allows you to reduce the operating noise of this machine. Select when you wish to reduce the operating noise of the printer at night, etc.

Using this function may lower the print speed.

The procedure for using the quiet mode is as follows:



### Quiet Settings

1. Open the printer driver setup window
2. Click **Quiet Settings** on the **Maintenance** tab

The **Quiet Settings** dialog box opens.

#### ▶▶▶ Note

- If the machine is off or if communication between the machine and the computer is disabled, an error message may appear because the computer cannot collect the machine status.

3. Set the quiet mode

If necessary, specify one of the following items:

#### **Do not use quiet mode**

Select this option when you wish to use the machine with volume of normal operating noise.

#### **Always use quiet mode**

Select this option when you wish to reduce the operating noise of the machine.

#### **Use quiet mode during specified hours**

Select this option when you wish to reduce the operating noise of the machine during a specified period of time. Set the **Start time** and the **End time** of the quiet mode you wish to be activated. If both are set to the same time, the quiet mode will not function.

#### ▶▶▶ Important

- You can set the quiet mode from the operation panel of the machine, the printer driver, or ScanGear (scanner driver).  
No matter how you use to set the quiet mode, the mode is applied when you perform operations from the operation panel of the machine or printing and scanning from the computer.
- If you specify a time for **Use quiet mode during specified hours**, quiet mode is not applied to operations (copy, direct print, etc.) performed directly from the machine.

4. Apply the settings

Make sure that the machine is on and click **OK**.

Click **OK** when the confirmation message appears.

The settings are enabled hereafter.

#### ▶▶▶ Note

- The effects of the quiet mode may be less depending on the print quality settings.

# Changing the Machine Operation Mode

If necessary, switch between various modes of machine operation.

The procedure for configuring **Custom Settings** is as follows:



## Custom Settings

1. Open the printer driver setup window
2. Make sure that the machine is on, and then click **Custom Settings** on the **Maintenance** tab

The **Custom Settings** dialog box opens.

### ▶▶▶ Note

- If the machine is off or if communication between the machine and the computer is disabled, an error message may appear because the computer cannot collect the machine status. If this happens, click **OK** to display the most recent settings specified on your computer.

3. If necessary, complete the following settings:

#### **Prevent paper abrasion**

The machine can increase the gap between the print head and the paper during high-density printing to prevent paper abrasion.

Check this check box to prevent paper abrasion.

#### **Align heads manually**

Usually, the **Print Head Alignment** function on the **Maintenance** tab is set to automatic head alignment, but you can change it to manual head alignment.

If the printing results are unsatisfactory even after you execute automatic head alignment, [execute manual head alignment](#).

Check this check box to perform the manual head alignment. Uncheck this check box to perform the automatic head alignment.

#### **Prevent paper double-feed**

Select this check box only if the machine is feeding multiple sheets of plain paper at the same time.

### ▶▶▶ Important

- Using this function slows down the print speed.

#### **Rotate 90 degrees left when orientation is [Landscape]**

On the **Page Setup** tab, you can change the rotation direction of the **Landscape** in the **Orientation**.

To rotate the print data 90 degrees to the left during printing, select this item. To rotate the print data 90 degrees to the right during printing, clear this item.

### ▶▶▶ Important

- Do not change this setting while the print job is displayed in the print wait list. Otherwise, characters may be omitted or the layout may become corrupt.

#### **Detect the paper width when printing from computer**

When you print from the computer, this function identifies the paper that was loaded into this machine.

When the paper width detected by the machine differ from the width of the paper specified in **Page Size** on the

**Page Setup** tab, a message is displayed.

To use paper width detection when printing from the computer, select the check box.

### **Important**

- If you are using user-defined paper, use the **Custom Paper Size** to correctly set the size of the paper loaded in the machine.  
If an error message is displayed even though the same size that was set is loaded, clear the check box.

#### **Ink Drying Wait Time**

You can set the length of the machine rest time until printing of the next page begins. Moving the slider to the right increases the pause time, and moving the slider to the left decreases the time.

If the paper gets stained because the next page is ejected before the ink on the printed page dries, increase the ink drying wait time.

Reducing the ink drying wait time speeds up printing.

#### **4. Apply the settings**

Click **OK** and when the confirmation message appears, click **OK**.

The machine operates with the modified settings hereafter.

## Changing the Machine Settings Using the Operation Panel

- ➔ [About Quiet setting](#)
- ➔ [Turning on/off the Machine Automatically](#)



## About Quiet setting

Enables this function on the machine if you want to reduce the operating noise, such as when printing at night.

Follow the procedure below to perform setting.

1. [Make sure that the machine is turned on.](#)
2. Press and hold the **Stop** button until the **Alarm** lamp flashes 9 times.
3. Release the **Stop** button.
4. Press the **Color** button.

To disable the function, press the **Black** button in step 4.

### ▶▶▶ Important

- Operating speed may be reduced compared to when the quiet mode is not selected.

### ▶▶▶ Note

- You can set the quiet mode from the operation panel of the machine, the printer driver, or ScanGear (scanner driver). No matter how you use to set the quiet mode, the mode is applied when you perform operations from the operation panel of the machine or printing and scanning from the computer.

## Turning on/off the Machine Automatically

You can enable the machine to turn on/off automatically considering the environment

➔ [Turning on the Machine Automatically](#)

➔ [Turning off the Machine Automatically](#)

### Turning on the Machine Automatically

You can enable the machine to turn on automatically when a scanning command from a computer or printing data is sent to the machine.

1. [Make sure that the machine is turned on.](#)
2. Press and hold the **Stop** button until the **Alarm** lamp flashes 14 times.
3. Release the **Stop** button.
4. Press the **Color** button.

To disable the function, press the **Black** button in step 4.

#### ▶▶▶ Note

- You can select whether you turn the machine on automatically from the operation panel of the machine, the printer driver, or ScanGear (scanner driver). No matter how you use to set the quiet mode, the mode is applied when a scanning command from a computer or printing data is sent to the machine.

### Turning off the Machine Automatically

You can enable the machine to turn off automatically when no operation is made or no printing data is sent to the machine for a specified period of time.

1. [Make sure that the machine is turned on.](#)
2. Press and hold the **Stop** button until the **Alarm** lamp flashes 13 times.
3. Release the **Stop** button.
4. Press the **Color** button.

To disable the function, press the **Black** button in step 4.

#### ▶▶▶ Note

- You can select whether you turn off the machine automatically from the operation panel of the machine, the printer driver, or ScanGear (scanner driver). From the printer driver or ScanGear (scanner driver), you can specify the time before turning off the machine.

## Information about Network Connection

➔ [Useful Information about Network Connection](#)

## Useful Information about Network Connection

- ➔ [Initial Values Set at Factory \(Network\)](#)
- ➔ [Connecting the Machine to the Computer Using a USB Cable](#)
- ➔ [When Detecting the Printers Have the Same Name during Setup](#)
- ➔ [Connecting to Other Computer with LAN/Changing the Connection Method from USB to LAN](#)
- ➔ [Printing Out Network Setting Information](#)

## Initial Values Set at Factory (Network)

| Item                                      | Initial Values      |
|---|---------------------|
| Enable/disable Wireless LAN               | Enable              |
| SSID                                      | BJNPSETUP           |
| Communication mode                        | Infrastructure      |
| Wireless LAN security                     | Disable             |
| IPv4 IP address                           | Auto setup          |
| IPv6 IP address                           | Auto setup          |
| Set printer name                          | XXXXXX000000        |
| Enable/disable IPv6                       | Enable              |
| Enable/disable WSD (WSD settings)         | Enable              |
| Timeout setting (WSD settings)            | 1 minute            |
| Enable/disable Bonjour (Bonjour settings) | Enable              |
| Service name (Bonjour settings)           | Canon MG3500 series |
| LPR protocol setting                      | Enable              |
| Wireless LAN DRX                          | Enable              |

("X" is the last six digits of MAC address.)

## Connecting the Machine to the Computer Using a USB Cable

Connect the machine and the computer using a USB cable as the illustration below. The USB port is located on the rear of the machine.

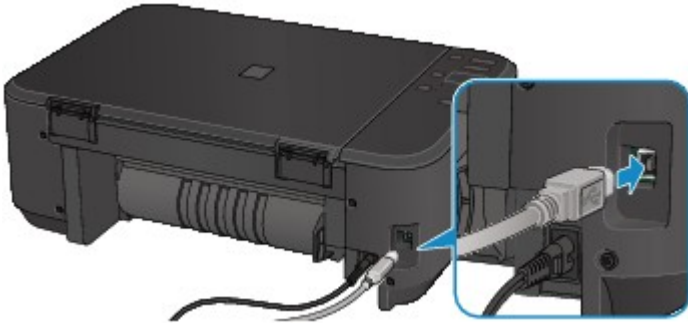

## When Detecting the Printers Have the Same Name during Setup

When the printer is detected during setup, you may see multiple printers of the same name on the detection result screen.

Select a printer with checking the MAC address set to the printer against the MAC address on detection result screen.

To check the MAC address of the printer, print out the network setting information using the operation panel of the printer.

➡ [Printing Out Network Setting Information](#)

## **Connecting to Other Computer with LAN/Changing the Connection Method from USB to LAN**

To add the computer connecting the printer with LAN or to change the connection method between the printer and the computer from USB to LAN, perform setup with the Setup CD-ROM or perform it according to the instructions on our website.

### **Connecting to Other Computer with LAN**

To add the computer connecting the printer with LAN, perform setup with the Setup CD-ROM or perform it according to the instructions on our website.

### **Changing the Connection Method from USB to LAN**

To change the connection method between the printer and the computer from USB to LAN, perform setup with the Setup CD-ROM or perform it according to the instructions on our website.

To change the connection method to LAN while you are using the printer with USB connection, perform setup again with the Setup CD-ROM or perform it again according to the instructions on our website and select **Change Connection Method**.



## Printing Out Network Setting Information

You can print out the network settings of the machine such as its IP address and SSID.

### ▶▶▶ Important

- This print out contains valuable information about your computer. Handle it with care.

1. [Make sure that the machine is turned on.](#)
2. [Load a sheet of A4 or Letter-sized plain paper.](#)
3. Press and hold the **Stop** button until the **Alarm** lamp flashes 15 times.
4. Release the **Stop** button.

The machine starts printing the network setting information.

The following information on the machine's network setting is printed out.

| Item                    | Explanations of the item     | Setting                                    |
|-------------------------|------------------------------|--|
| Wireless LAN            | Wireless LAN                 | Enable/Disable                             |
| Connection              | Status of the Wireless LAN   | Active/Inactive                            |
| MAC Address             | MAC Address                  | XX:XX:XX:XX:XX:XX                          |
| SSID                    | SSID                         | SSID of the wireless LAN                   |
| Communication Mode      | Communication Mode           | Infrastructure                             |
| Channel                 | Channel                      | XX (1 to 13)                               |
| Encryption              | Method of the Encryption     | none/WEP/TKIP/AES                          |
| WEP Key Length          | WEP Key Length               | Inactive/128/64                            |
| Authentication          | Method of the Authentication | none/auto/open/shared/WPA-PSK/WPA2-PSK     |
| Signal Strength         | Signal Strength              | 0 to 100 [%]                               |
| TCP/IP Version          | TCP/IP Version               | IPv4 & IPv6/IPv4                           |
| IPv4 IP Address         | Selected IP Address (IPv4)   | XXX.XXX.XXX.XXX                            |
| IPv4 Default Gateway    | Default Gateway (IPv4)       | XXX.XXX.XXX.XXX                            |
| Subnet Mask             | Subnet Mask                  | XXX.XXX.XXX.XXX                            |
| IPv6 IP Address *1      | Selected IP Address (IPv6)   | XXXX:XXXX:XXXX:XXXX<br>XXXX:XXXX:XXXX:XXXX |
| IPv6 Default Gateway *1 | Default Gateway (IPv6)       | XXXX:XXXX:XXXX:XXXX<br>XXXX:XXXX:XXXX:XXXX |

|                        |  |  |
|------------------------|--|--|
| Subnet Prefix Length*1 | Subnet Prefix Length                   | XXX  |
| IPsec*2                | IPsec setting                          | Active                                     |
| Security Protocol*2    | Method of the Security Protocol        | ESP/ESP & AH/AH                            |
| WPS PIN CODE           | WPS PIN code                           | XXXXXXXX                                   |
| Wireless LAN DRX       | Discontinuous reception (wireless LAN) | Enable/Disable                             |
| Other Settings         | Other settings                         | -  |
| Printer Name           | Printer name                           | Printer name (Up to 15 characters)         |
| WSD                    | WSD setting                            | Enable/Disable                             |
| WSD Timeout            | Timeout                                | 1/5/10/15/20 [min]                         |
| LPR Protocol           | LPR protocol setting                   | Enable/Disable                             |
| Bonjour                | Bonjour setting                        | Enable/Disable                             |
| Bonjour Service Name   | Bonjour service name                   | Bonjour service name (Up to 52 characters) |
| DNS Server             | Getting DNS Server automatically       | Auto/Manual                                |
| Primary Server         | Primary server address                 | XXX.XXX.XXX.XXX                            |
| Secondary Server       | Secondary server address               | XXX.XXX.XXX.XXX                            |
| Proxy Server           | Proxy Server setting                   | Enable/Disable                             |
| Proxy Port             | Specifying Proxy Port                  | 1 to 65535                                 |
| Proxy Address          | Proxy Address                          | XXXXXXXXXXXXXXXXXXXXXX                     |
| IP Address Filtering   | IP Address Filtering                   | Enable/Disable                             |

("XX" represents alphanumeric characters.)

\*1 Only when IPv6 is activated, the status of the network is printed.

\*2 Only IPv6 and the IPsec setting are activated, the status of the network is printed.

## About Network Communication

- ➔ [Changing and Confirming Network Settings](#)
- ➔ [Screens for Network Connection of IJ Network Tool](#)
- ➔ [Other Screens of IJ Network Tool](#)
- ➔ [Appendix for Network Communication](#)

## Changing and Confirming Network Settings

- ➔ [IJ Network Tool](#)
- ➔ [Changing the Settings in the Wireless LAN Sheet](#)
- ➔ [Changing the WEP Detailed Settings](#)
- ➔ [Changing the WPA or WPA2 Detailed Settings](#)
- ➔ [Changing the Settings in the Wired LAN Sheet](#)
- ➔ [Changing the Settings in the Admin Password Sheet](#)
- ➔ [Monitoring Wireless Network Status](#)
- ➔ [Initializing the Network Settings of the Machine](#)
- ➔ [Viewing the Modified Settings](#)

# IJ Network Tool

IJ Network Tool is a utility that enables you to display and modify the machine network settings. It is installed when the machine is set up.

## »» Important

- To use the machine over LAN, make sure you have the equipment necessary for the connection type, such as an access point or a LAN cable.
- Do not start up IJ Network Tool while printing.
- Do not print when IJ Network Tool is running.
- If the firewall function of your security software is turned on, a message may appear warning that Canon software is attempting to access the network. If the warning message appears, set the security software to always allow access.
- IJ Network Tool has been verified to work on Windows XP, however, it does not support Fast User Switching. It is recommended to exit IJ Network Tool when switching users.

## Starting up IJ Network Tool

1. Start up IJ Network Tool as shown below.

- In Windows 8, select **IJ Network Tool** on the **Start** screen to start IJ Network Tool. If **IJ Network Tool** is not displayed on the **Start** screen, select the **Search** charm, then search for "IJ Network Tool".
- In Windows 7, Windows Vista, or Windows XP, click **Start** and select **All programs, Canon Utilities, IJ Network Tool**, and then **IJ Network Tool**.

## »» Note

- You can also start up IJ Network Tool by clicking  **Network Settings** from **Device Settings & Maintenance** on Quick Menu.

## Changing the Settings in the Wireless LAN Sheet

To change the wireless network settings of the printer, connect the printer and the computer with a USB cable temporarily. If you modify the wireless network settings of the computer over wireless connection without USB connection, your computer may not be able to communicate with the machine after modifying the settings.

### ▶▶▶ Note

- This screen is not available depending on the printer you are using.
- Activate the wireless LAN setting of the printer to change the settings in the **Wireless LAN** sheet.

1. [Start up IJ Network Tool.](#)

2. Select the printer in **Printers:**.

When the printer is connected to the computer with a USB cable temporarily, select the printer with "USBnnn" (where "n" is a number) appearing in the **Port Name** column.

3. Select **Configuration...** from the **Settings** menu.

4. Click the **Wireless LAN** tab.

The **Wireless LAN** sheet is displayed.

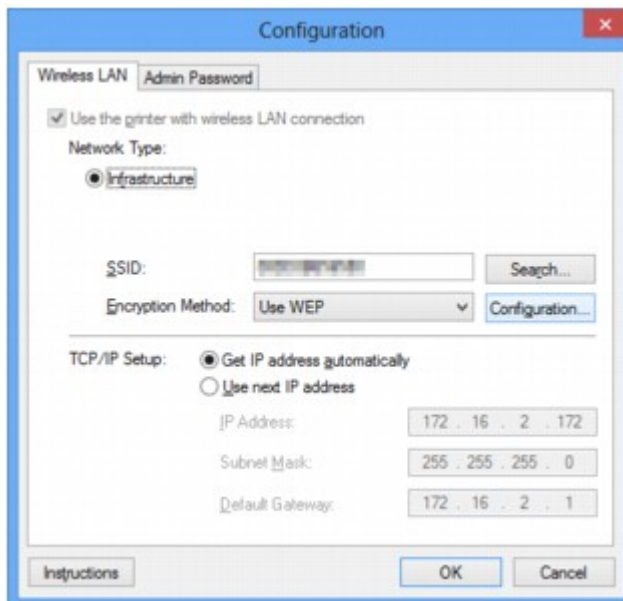

For details on the **Wireless LAN** sheet, see [Wireless LAN Sheet](#).

5. Change the settings or confirm.

#### SSID:

Enter the same value that was set for the target access point.

When the printer is connected with USB, the **Search** screen appears by clicking **Search...**. Set the SSID of the access point by selecting the one of the detected access points.

➡ [Search Screen](#)

## ►►► Note

- Enter the same SSID that the access point is configured to use. The SSID is case-sensitive.

### Encryption Method:

Select the encryption method used over the wireless LAN.

You can change WEP settings with selecting **Use WEP** and clicking **Configuration...**

➔ [Changing the WEP Detailed Settings](#)

You can change WPA or WPA2 settings with selecting **Use WPA** or **Use WPA2** and clicking **Configuration...**

➔ [Changing the WPA or WPA2 Detailed Settings](#)

## ►►► Important

- If all encryption types of the access point, printer, or computer do not match, the printer cannot communicate with the computer. If the printer cannot communicate with the computer after the encryption type of the printer was switched, make sure that encryption types for the computer and the access point matches that set to the printer.
- If you connect to a network that is not protected with security measures, there is a risk of disclosing data such as your personal information to a third party.

### TCP/IP Setup:

Sets the IP address of the printer to be used over the LAN. Set a value appropriate for your network environment.

## 6. Click **OK**.

After changing configuration, a screen is displayed asking you for confirmation before the settings are sent to the printer. If you click **Yes**, the settings are sent to the printer and the **Transmitted Settings** screen is displayed.

## ►►► Note

- Changing the network settings with the USB cable temporarily may switch the default printer. In this case, reset **Set as Default Printer**.

# Changing the WEP Detailed Settings

## ▶▶▶ Note

- This screen is not available depending on the printer you are using.

To change the wireless network settings of the printer, connect the printer and the computer with a USB cable temporarily. If you modify the wireless network settings of the computer over wireless connection without USB connection, your computer may not be able to communicate with the machine after modifying the settings.

1. [Start up IJ Network Tool.](#)

2. Select the printer in **Printers:**.

When the printer is connected to the computer with a USB cable temporarily, select the printer with "USBnnn" (where "n" is a number) appearing in the **Port Name** column.

3. Select **Configuration...** from the **Settings** menu.

4. Click the **Wireless LAN** tab.

5. Select **Use WEP** in **Encryption Method:** and click **Configuration....**

The **WEP Details** screen is displayed.

6. Change the settings or confirm.

When changing the password (WEP key), the same change must be made to the password (WEP key) of the access point.

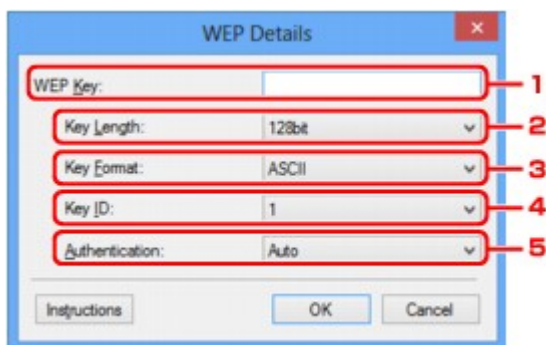

### 1. **WEP Key:**

Enter the same key as the one set to the access point.

The number of characters and character type that can be entered differ depending on the key length and key format.

|            |       | Key Length   |               |
|------------|-------|--------------|---------------|
|            |       | 64bit        | 128bit        |
| Key Format | ASCII | 5 characters | 13 characters |



|  |                            |           |           |
|--|----------------------------|-----------|-----------|
|  | Hexadecimal ( <b>Hex</b> ) | 10 digits | 26 digits |
|--|----------------------------|-----------|-----------|

2. **Key Length:**

Select either **64bit** or **128bit**.

3. **Key Format:**

Select either **ASCII** or **Hex**.

4. **Key ID:**

Select the Key ID (index) set to the access point.

5. **Authentication:**

Select the authentication method to authenticate the printer's access to the access point.

Normally, select **Auto**. If you want to specify the method manually, select **Open System** or **Shared Key** according to the setting of the access point.

7. Click **OK**.

 **Important**

- If the printer cannot communicate with the computer after the encryption type of the printer was switched, make sure that encryption types for the computer and the access point matches that set to the printer.

 **Note**

- Changing the network settings with the USB cable temporarily may switch the default printer. In this case, reset **Set as Default Printer**.

# Changing the WPA or WPA2 Detailed Settings

## ▶▶▶ Note

- This screen is not available depending on the printer you are using.

To change the wireless network settings of the printer, connect the printer and the computer with a USB cable temporarily. If you modify the wireless network settings of the computer over wireless connection without USB connection, your computer may not be able to communicate with the machine after modifying the settings.

The example screenshots in this section refer to the WPA detailed settings.

1. [Start up IJ Network Tool.](#)

2. Select the printer in **Printers:**.

When the printer is connected to the computer with a USB cable temporarily, select the printer with "USBnnn" (where "n" is a number) appearing in the **Port Name** column.

3. Select **Configuration...** from the **Settings** menu.

4. Click the **Wireless LAN** tab.

5. Select **Use WPA** or **Use WPA2** in **Encryption Method:** and click **Configuration....**

The **WPA Details** screen is displayed (For WPA2, the **WPA2 Details** screen is displayed).

If encryption is not set to the printer, the **Authentication Type Confirmation** screen is displayed. Go to step 7.

6. Click **Change Settings....**

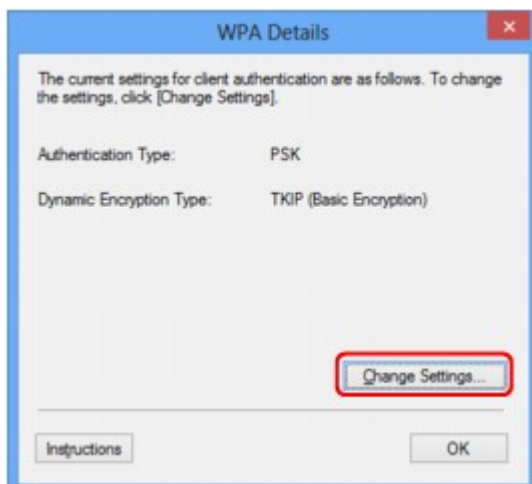

7. Check the client authentication type and click **Next>**.



8. Enter the passphrase, confirm the type of dynamic encryption and click **Next>**.

Enter the passphrase set to the access point. The passphrase should be a string of 8 to 63 alphanumeric characters or a 64-digit hexadecimal value.

If you do not know the access point passphrase, refer to the instruction manual provided with the access point or contact its manufacturer.



9. Click **Finish**.

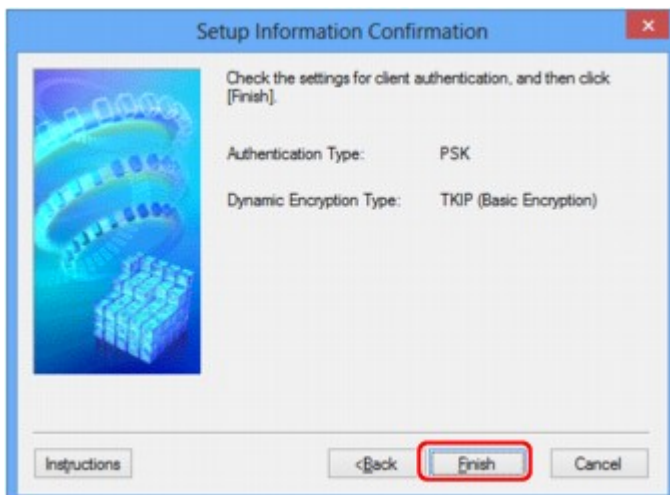

### Important

- If the printer cannot communicate with the computer after the encryption type of the printer was switched, make sure that encryption types for the computer and the access point matches that set to the printer.

### Note

- Changing the network settings with the USB cable temporarily may switch the default printer. In this case, reset **Set as Default Printer**.

# Changing the Settings in the Wired LAN Sheet

## ▶▶▶ Note

- This screen is not available depending on the printer you are using.
- Activate the wired LAN setting of the printer to change the settings in the **Wired LAN** sheet.

1. [Start up IJ Network Tool.](#)
2. Select the printer in **Printers:**.
3. Select **Configuration...** from the **Settings** menu.
4. Click the **Wired LAN** tab.

The **Wired LAN** sheet is displayed.

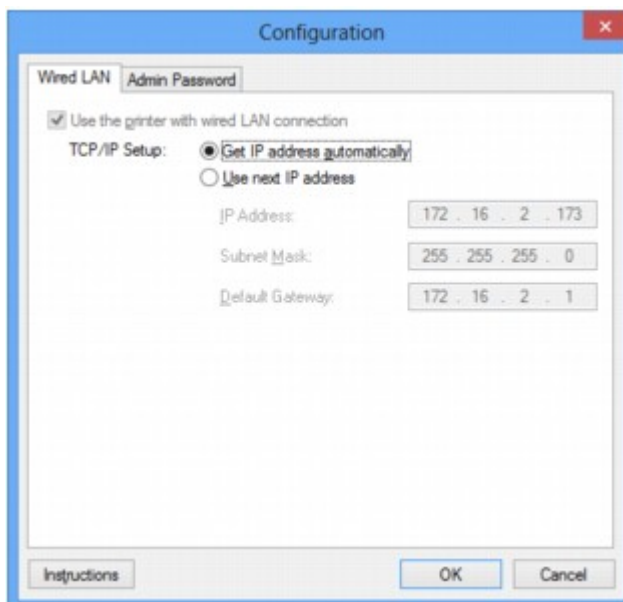

For details on the **Wired LAN** sheet, see [Wired LAN Sheet](#).

5. Change the settings or confirm.

Sets the IP address of the printer to be used over the LAN. Set a value appropriate for your network environment.

6. Click **OK**.

After changing configuration, a screen is displayed asking you for confirmation before the settings are sent to the printer. If you click **Yes**, the settings are sent to the printer and the **Transmitted Settings** screen is displayed.

## Changing the Settings in the Admin Password Sheet

1. [Start up IJ Network Tool.](#)
2. Select the printer in **Printers:**.
3. Select **Configuration...** from the **Settings** menu.
4. Click the **Admin Password** tab.

The **Admin Password** sheet is displayed.

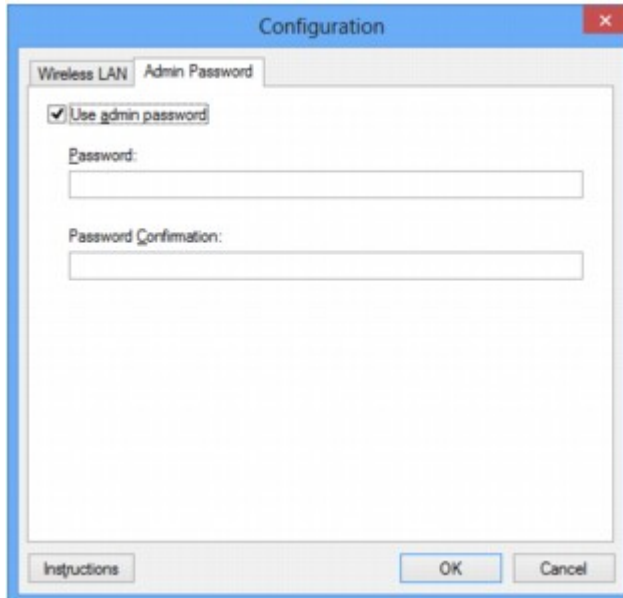

For details on the **Admin Password** sheet, see [Admin Password Sheet](#).

5. Change the settings or confirm.

To use admin password, select the **Use admin password** check box and enter a password.

### »»» Important

- The password should consist of alphanumeric characters and be no longer than 32 characters. The password is case-sensitive. Do not forget the password you set.

6. Click **OK**.

A screen is displayed asking you for confirmation before the settings are sent to the printer. If you click **Yes**, the settings are sent to the printer and the **Transmitted Settings** screen is displayed.

# Monitoring Wireless Network Status

## ►►► Note

- This screen is not available depending on the printer you are using.
- When using the machine over the wired LAN, you cannot monitor network status.

1. [Start up IJ Network Tool.](#)
2. Select the printer in **Printers:**.
3. Select **Status** from the **View** menu.

The **Status** screen is displayed and you can check the printer status and connection performance.

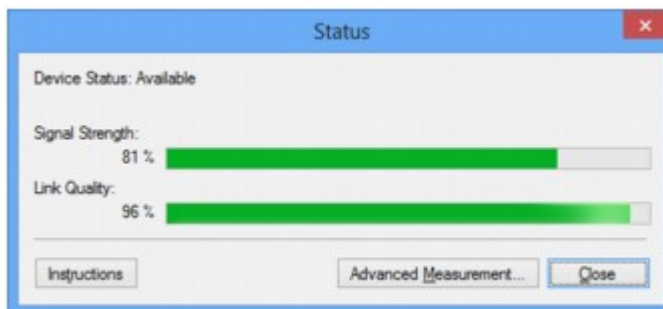

## ►►► Important

- If the indicated value is low, move your printer closer to the wireless network device.

4. If you measure the connection performance in detail, click **Advanced Measurement....**

The **Connection Performance Measurement** screen is displayed.

5. Click **Next>**.

The measurement starts and the status displays. Measurement takes a few minutes.

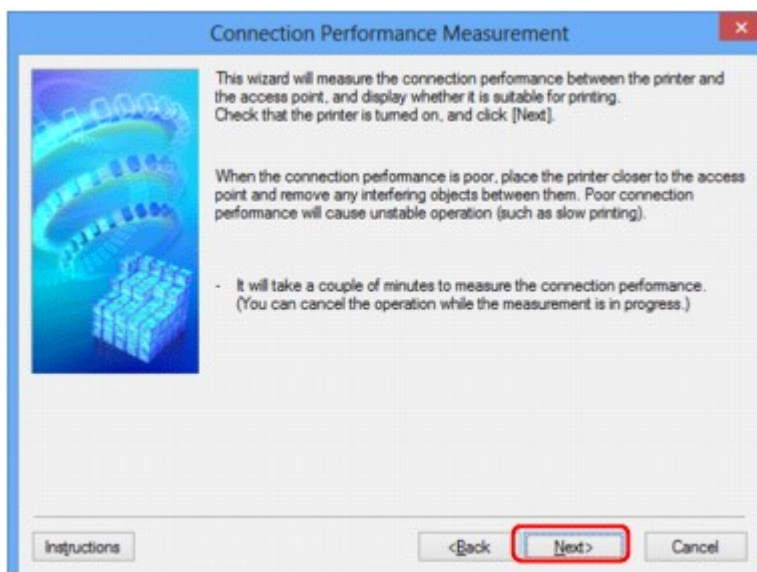

## 6. Check the status.

When the measurement is complete, the status is displayed.

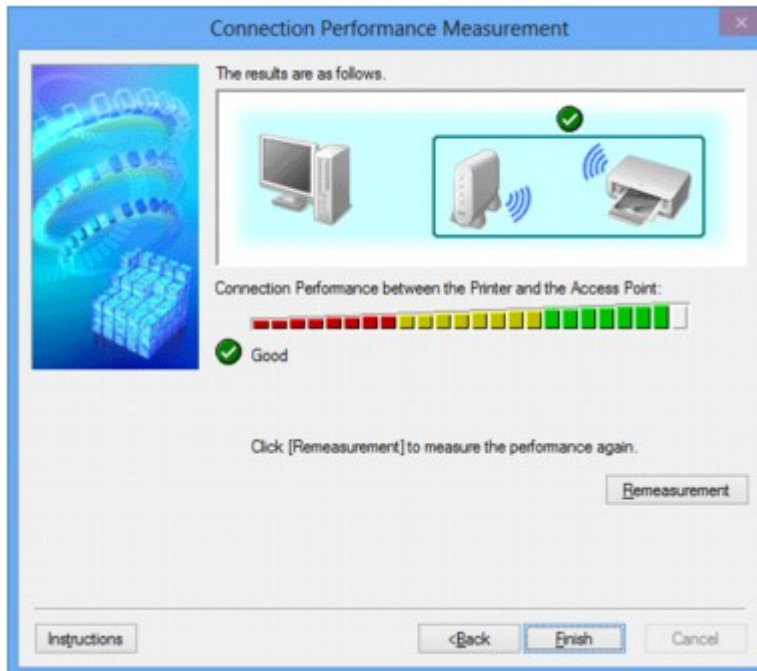

When  is displayed in **Connection Performance between the Printer and the Access Point:**, the printer can communicate with the access point. Otherwise, refer to displayed comments and the following to improve the status of communication link, and click **Remeasurement**.

- Check that the printer and the access point are located within the wireless connectivity range with no obstacles between them.
- Check if the distance between the printer and the access point is not too far.  
If they are too far, move them closer together (within 164 ft./50 m).
- Check that there is no barrier or obstacle between the printer and the access point.  
In general, connection performance decreases for communications through walls or between different floors. Adjust the locations to avoid such situations.
- Check that there are no sources of radio interference near the printer and the access point.  
The wireless connection may use the same frequency band as microwave ovens and other sources of radio interference. Try to keep the printer and the access point away from such sources.
- Check if the radio channel of the access point is close to that of other access points nearby.  
If the radio channel of the access point is close to that of other access points nearby, the connection performance may become unstable. Be sure to use a radio channel that does not interfere with other access points.
- Check that the printer and the access point face each other.  
Connection performance may depend on the orientations of the wireless devices. Replace the access point and the printer in another direction to achieve the best performance.
- Check whether other computers are not accessing the printer.

If  appears in the result of the measurement, check whether other computers are not accessing the printer.



If  still appears even if you have tried the above, finish the measurement, then restart the IJ Network Tool to start over the measurement.

7. Click **Finish**.

 **Note**

- If any messages appear on **Overall Network Performance:**, move the machine and access point as instructed to improve the performance.

# Initializing the Network Settings of the Machine

## ▶▶▶ Important

- Note that initialization erases all network settings on the machine, printing or scanning operation from a computer over network may become impossible. To use the machine over network, perform setup with the Setup CD-ROM or perform setup according to the instructions on our website.

1. [Start up IJ Network Tool.](#)
2. Select the printer in **Printers:**.
3. Select **Maintenance...** from the **Settings** menu.  
The **Maintenance** screen is displayed.
4. Click **Initialize.**

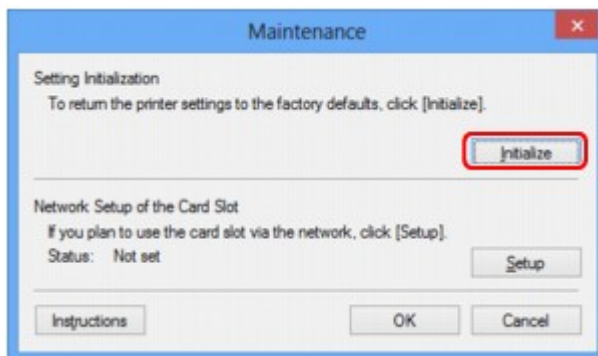

5. When the confirmation screen is displayed, click **Yes.**

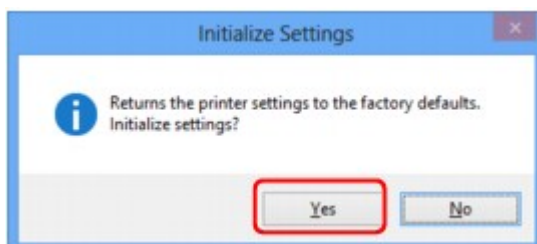

The network settings of the printer is initialized.

Do not turn off the printer during initialization.

Click **OK** when initialization is complete.

Performing initialization when connected over wireless LAN will break the connection, so perform setup with the Setup CD-ROM or perform setup according to the instructions on our website.

## ▶▶▶ Note

- You can change the network settings of the printer using IJ Network Tool with USB connection after initializing the LAN settings. To change the network settings using Canon IJ Network Tool, activate wireless LAN in advance.

## Viewing the Modified Settings

The **Confirmation** screen is displayed when you modified the printer settings on the **Configuration** screen. When you click **Yes** on the **Confirmation** screen, the following screen is displayed for confirming the modified settings.

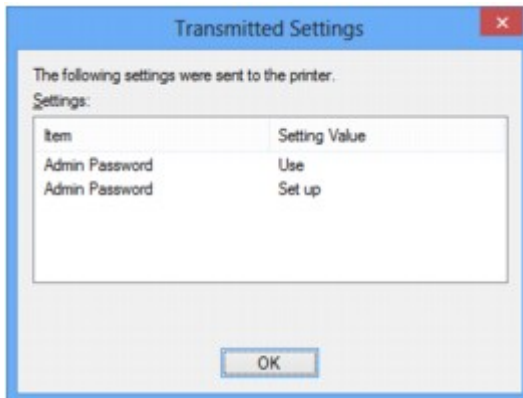

## Screens for Network Connection of IJ Network Tool

- ➔ [Canon IJ Network Tool Screen](#)
- ➔ [Configuration Screen](#)
- ➔ [Wireless LAN Sheet](#)
- ➔ [Search Screen](#)
- ➔ [WEP Details Screen](#)
- ➔ [WPA Details Screen](#)
- ➔ [WPA2 Details Screen](#)
- ➔ [Authentication Type Confirmation Screen](#)
- ➔ [PSK: Passphrase and Dynamic Encryption Setup Screen](#)
- ➔ [Setup Information Confirmation Screen](#)
- ➔ [Wired LAN Sheet](#)
- ➔ [Admin Password Sheet](#)
- ➔ [Network Information Screen](#)
- ➔ [Access Control Sheet](#)
- ➔ [Edit Accessible MAC Address Screen/Add Accessible MAC Address Screen](#)
- ➔ [Edit Accessible IP Address Screen/Add Accessible IP Address Screen](#)

# Canon IJ Network Tool Screen

This section describes the items and menus displayed on the **Canon IJ Network Tool** screen.

➔ [Items on the Canon IJ Network Tool Screen](#)

➔ [Canon IJ Network Tool Menus](#)

## Items on the Canon IJ Network Tool Screen

The following item is displayed on the **Canon IJ Network Tool** screen.

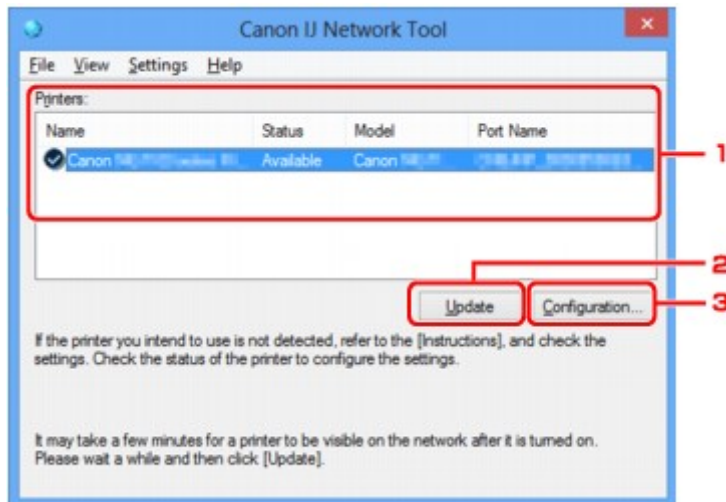

### 1. Printers:

The printer name, status, printer model name, and port name are displayed.

A check mark next to the printer in the **Name** list indicates it is set as the default printer.

Configuration changes are applied to the selected printer.

### 2. Update

Performs printer detection again. Click this button if the target printer is not displayed.

#### ▶▶▶ Important

- To change the printer's network settings using IJ Network Tool, it must be connected via a LAN.
- If **No Driver** is displayed for the name, associate the port with the printer.  
➔ [When the Printer Driver Is Not Associated with a Port](#)
- If **Not Found** is displayed for the status, check the followings:
  - The access point is turned on.
  - When using wired LAN, the LAN cable is connected properly.
- If the printer on a network is not detected, make sure that the printer is turned on, then click **Update**. It may take several minutes to detect printers. If the printer is not yet detected, connect the machine and the computer with a USB cable, then click **Update**.
- If the printer is being used from another computer, a screen is displayed informing you of this condition.

## ►►► Note

- This item has the same function as **Refresh** in the **View** menu.

### 3. Configuration...

Click to configure settings of the selected printer.

➔ [Configuration Screen](#)

## ►►► Note

- You cannot configure a printer that has the status **Not Found**.
- This item has the same function as **Configuration...** in the **Settings** menu.

## Canon IJ Network Tool Menus

The following menu is displayed from the **Canon IJ Network Tool** screen.

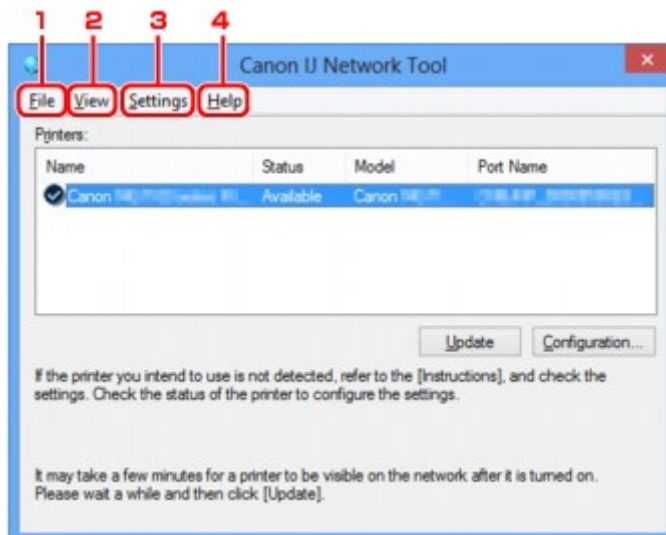

#### 1. File menu

##### Exit

Exits IJ Network Tool.

#### 2. View menu

##### Status

Displays the **Status** screen to confirm the printer connection status and wireless communication status.

➔ [Status Screen](#)

##### Refresh

Updates and displays the contents of **Printers:** on the **Canon IJ Network Tool** screen to the latest information.

## ►►► Important

- To change the printer's network settings using IJ Network Tool, it must be connected via a LAN.
- If **No Driver** is displayed for the name, associate the port with the printer.

➔ [When the Printer Driver Is Not Associated with a Port](#)

- If **Not Found** is displayed for the status, check the followings:
  - The access point is turned on.
  - When using wired LAN, the LAN cable is connected properly.
- If the printer on a network is not detected, make sure that the printer is turned on, then select **Refresh**. It may take several minutes to detect printers. If the printer is not yet detected, connect the machine and the computer with a USB cable, then select **Refresh**.
- If the printer is being used from another computer, a screen is displayed informing you of this condition.

### ▶▶▶ Note

- This item has the same function as **Update** in the **Canon IJ Network Tool** screen.

#### Network Information

Displays the **Network Information** screen to confirm the network settings of the printer and the computer.

➔ [Network Information Screen](#)

#### Display Warning Automatically

Enables or disables automatic display of the instruction screen.

When this menu is selected, the instruction screen is displayed if one or more ports are unavailable for printing.

### 3. Settings menu

#### Configuration...

Displays the **Configuration** screen to configure settings of the selected printer.

➔ [Configuration Screen](#)

### ▶▶▶ Note

- This item has the same function as **Configuration...** in the **Canon IJ Network Tool** screen.

#### Associate Port...

Displays the **Associate Port** screen and you can associate a port with the printer.

➔ [Associate Port Screen](#)

This menu is available when **No Driver** is displayed for the selected printer. Associating a port with the printer enables you to use it.

#### Maintenance...

Displays the **Maintenance** screen to revert the network settings of the printer to factory default and to mount the card slot as the network drive.

➔ [Maintenance Screen](#)

### 4. Help menu

#### Instructions

Displays this guide.

#### About

Displays the version of IJ Network Tool.

## Configuration Screen

You can change the configuration of the printer selected on the **Canon IJ Network Tool** screen.

Click the tab to select the sheet to change the settings.

The following screen is the example to change the setting on the **Wireless LAN** sheet.

### ▶▶▶ Note

- This screen is not available depending on the printer you are using.

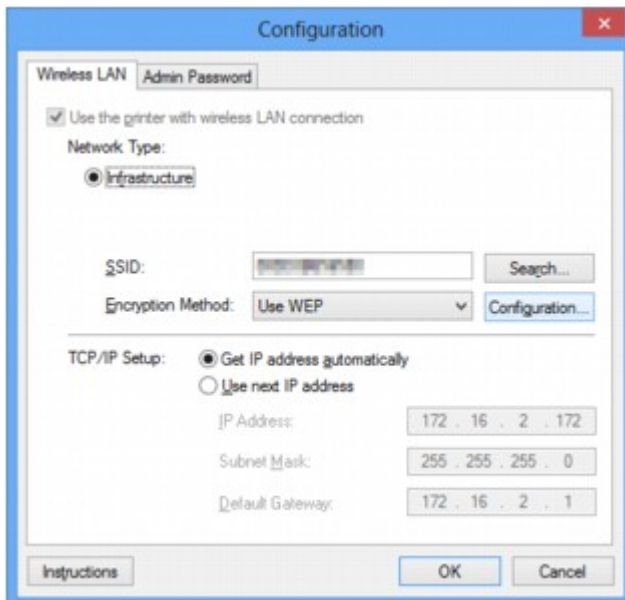

For details on each sheet, see the following.

➡ [Wireless LAN Sheet](#)

➡ [Wired LAN Sheet](#)

➡ [Admin Password Sheet](#)



# Wireless LAN Sheet

## ▶▶▶ Note

- This screen is not available depending on the printer you are using.

Allows you to set the printer with wireless LAN connection.

To display the **Wireless LAN** sheet, click the **Wireless LAN** tab on the **Configuration** screen.

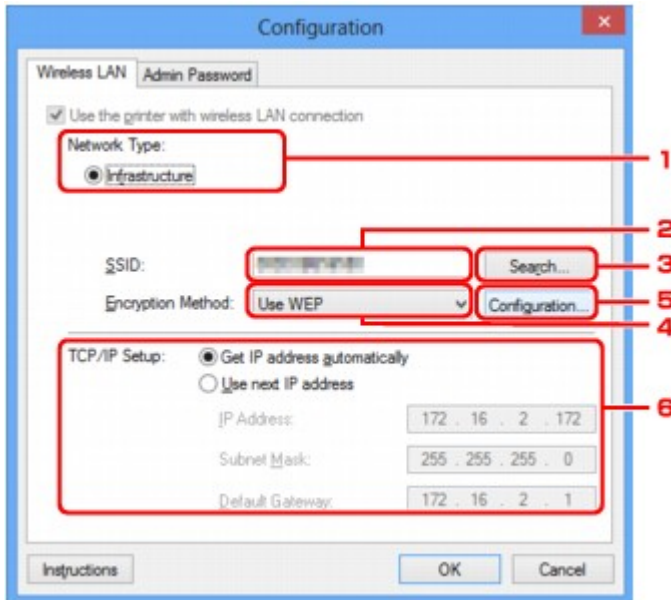

### 1. Network Type:

#### Infrastructure

Connects the printer to the wireless LAN with an access point.

### 2. SSID:

The SSID of the wireless LAN is displayed.

As the initial settings, the unique value is displayed.

## ▶▶▶ Note

- Enter the same SSID that the access point is configured to use. The SSID is case-sensitive.

### 3. Search...

The **Search** screen is displayed to select an access point to connect to.

➔ [Search Screen](#)

## ▶▶▶ Note

- When IJ Network Tool runs over a LAN, the button is grayed out and cannot be selected. Connect the printer and the computer with a USB cable temporarily to change the settings.

### 4. Encryption Method:

Select the encryption method used over the wireless LAN.

**Do not use**

Select to disable encryption.

**Use WEP**

Transmission is encrypted using a WEP key you specified.

If a WEP key has not been set, the **WEP Details** screen is displayed automatically. To change WEP settings set before, click **Configuration...** to display the screen.

➡ [Changing the WEP Detailed Settings](#)

**Use WPA/Use WPA2**

Transmission is encrypted using a WPA or WPA2 key you specified.

The security has been strengthened more than WEP.

If a WPA or WPA2 key has not been set, the **Authentication Type Confirmation** screen is displayed automatically. To change WPA or WPA2 settings set before, click **Configuration...** to display the **WPA Details** screen or **WPA2 Details** screen.

➡ [Changing the WPA or WPA2 Detailed Settings](#)

**5. Configuration...**

The detailed settings screen is displayed. The WEP, the WPA, or the WPA2 key selected in **Encryption Method:** can be confirmed and changed.

**For details on WEP setting:**

➡ [Changing the WEP Detailed Settings](#)

**For details on WPA or WPA2 setting:**

➡ [Changing the WPA or WPA2 Detailed Settings](#)

**6. TCP/IP Setup:**

Sets the IP address of the printer to be used over the LAN. Set a value appropriate for your network environment.

**Get IP address automatically**

Select this option to use an IP address automatically assigned by a DHCP server. DHCP server functionality must be enabled on your wireless LAN router or access point.

**Use next IP address**

If no DHCP server functionality is available in your setup where you use the printer or you want to use a particular IP address, select this option to use a fixed IP address.

# Search Screen

## ▶▶▶ Note

- This screen is not available depending on the printer you are using.

The access points detected are listed.

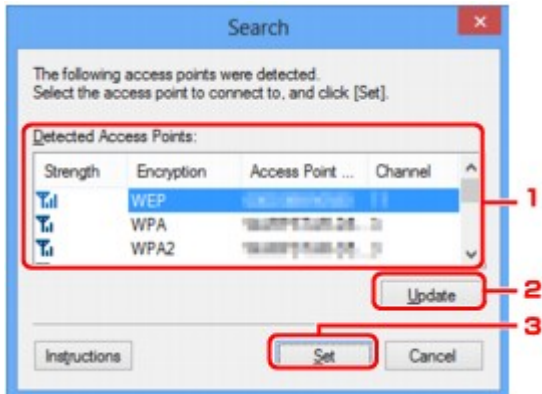

### 1. Detected Access Points:

The signal strength from the access point, encryption type, name of access point, and the radio channel can be confirmed.

## ▶▶▶ Important

- If you connect to a network that is not protected with security measures, there is a risk of disclosing data such as your personal information to a third party.

## ▶▶▶ Note

- Signal strength is displayed as follows.

Full : Good

Fair : Fair

Poor : Poor

- Type of encryption is displayed as follows.

Blank: No encryption

**WEP:** WEP is set

**WPA:** WPA is set

**WPA2:** WPA2 is set

### 2. Update

Click to update the list of access points when your target access point is not detected.

If the target access point is set to the stealth mode, click **Cancel** to return to the previous screen and enter the access point's SSID in **SSID:** on the **Wireless LAN** sheet.

➔ [Wireless LAN Sheet](#)

▶▶▶ **Note**

- When detecting your target access point, make sure that the access point is turned on.

### 3. **Set**

Click to set the access point's SSID in **SSID:** on the **Wireless LAN** sheet.

▶▶▶ **Note**

- The **WEP Details** screen, the **WPA Details** screen, or the **WPA2 Details** screen appears if the selected access point is encrypted. In this case, configure the details to use the same encryption settings set to the access point.
- Access points that cannot be used by this machine (including those configured to use different encryption methods) are displayed grayed out and cannot be configured.

# WEP Details Screen

## ▶▶▶ Note

- This screen is not available depending on the printer you are using.

Specify the printer WEP settings.

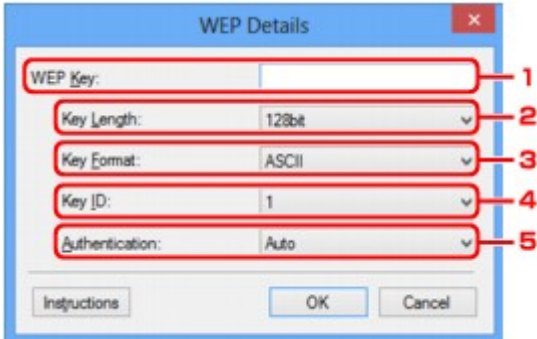

## ▶▶▶ Note

- When changing the password (WEP key) of the printer, the same change must be made to the password (WEP key) of the access point.

### 1. WEP Key:

Enter the same key as the one set to the access point.

The number of characters and character type that can be entered differ depending on the key length and key format.

|            |                   | Key Length   |               |
|------------|-------------------|--------------|---------------|
|            |                   | 64bit        | 128bit        |
| Key Format | ASCII             | 5 characters | 13 characters |
|            | Hexadecimal (Hex) | 10 digits    | 26 digits     |

### 2. Key Length:

Select either **64bit** or **128bit**.

### 3. Key Format:

Select either **ASCII** or **Hex**.

### 4. Key ID:

Select the Key ID (index) set to the access point.

### 5. Authentication:

Select the authentication method to authenticate the printer's access to the access point.

Select **Auto** or **Open System** or **Shared Key**.

# WPA Details Screen

## ▶▶▶ Note

- This screen is not available depending on the printer you are using.

Specify the printer WPA settings.

The value displayed on the screen differs depending on the present settings.

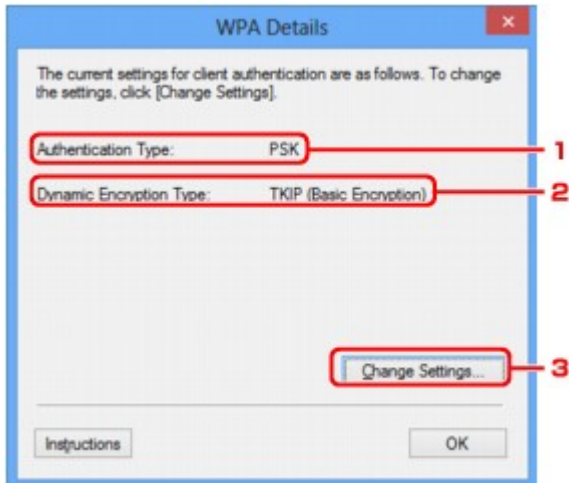

### 1. Authentication Type:

Displays the type of authentication used for client authentication. This machine supports the PSK authentication method.

### 2. Dynamic Encryption Type:

Displays the dynamic encryption method.

### 3. Change Settings...

Displays the **Authentication Type Confirmation** screen.

➡ [Authentication Type Confirmation Screen](#)

# WPA2 Details Screen

## ▶▶▶ Note

- This screen is not available depending on the printer you are using.

Specify the printer WPA2 settings.

The value displayed on the screen differs depending on the present settings.

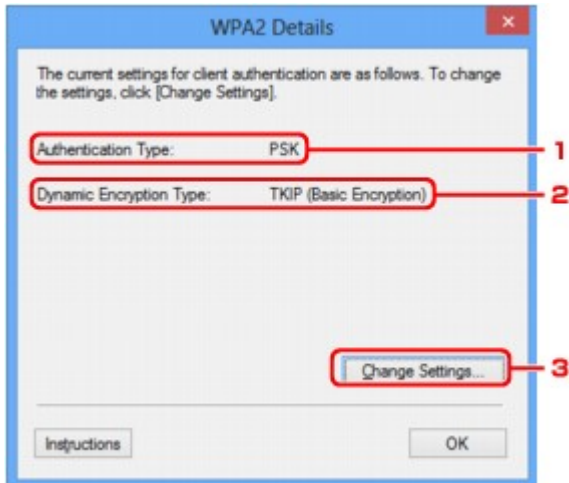

### 1. Authentication Type:

Displays the type of authentication used for client authentication. This machine supports the PSK authentication method.

### 2. Dynamic Encryption Type:

Displays the dynamic encryption method.

### 3. Change Settings...

Displays the **Authentication Type Confirmation** screen.

➡ [Authentication Type Confirmation Screen](#)

# Authentication Type Confirmation Screen

## ►►► Note

- This screen is not available depending on the printer you are using.

Type of authentication used for client authentication is displayed.

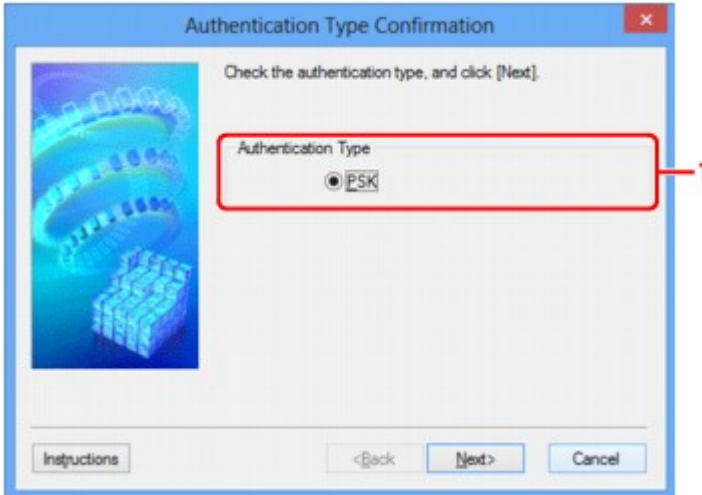

### 1. Authentication Type

Type of authentication used for client authentication is displayed.

#### PSK

This machine supports the **PSK** authentication method.

This authentication type **PSK** uses a passphrase.



# PSK: Passphrase and Dynamic Encryption Setup Screen

## ▶▶▶ Note

- This screen is not available depending on the printer you are using.

Enter the passphrase and select the dynamic encryption method.

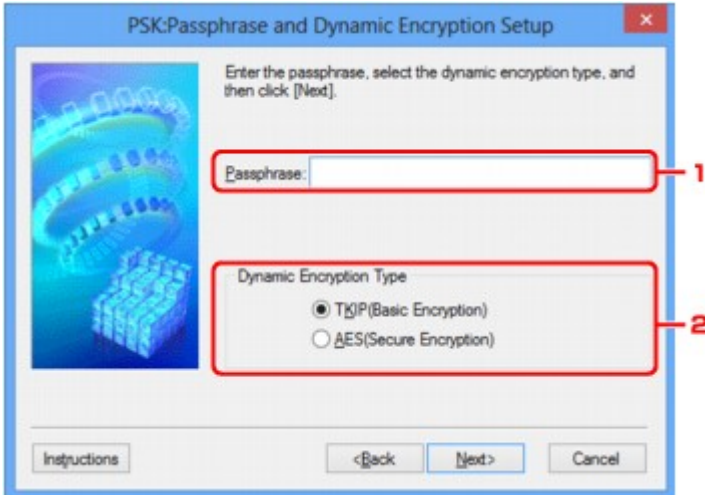

### 1. Passphrase:

Enter the passphrase set to the access point. The passphrase should be a string of 8 to 63 alphanumeric characters or a 64-digit hexadecimal value.

If you do not know the access point passphrase, refer to the instruction manual provided with the access point or contact its manufacturer.

### 2. Dynamic Encryption Type

Select the dynamic encryption method from either **TKIP (Basic Encryption)**, or **AES (Secure Encryption)** according to the setting of the access point.

## Setup Information Confirmation Screen

### ▶▶▶ Note

- This screen is not available depending on the printer you are using.

Displays the settings used for client authentication.

Confirm the settings and click **Finish**.

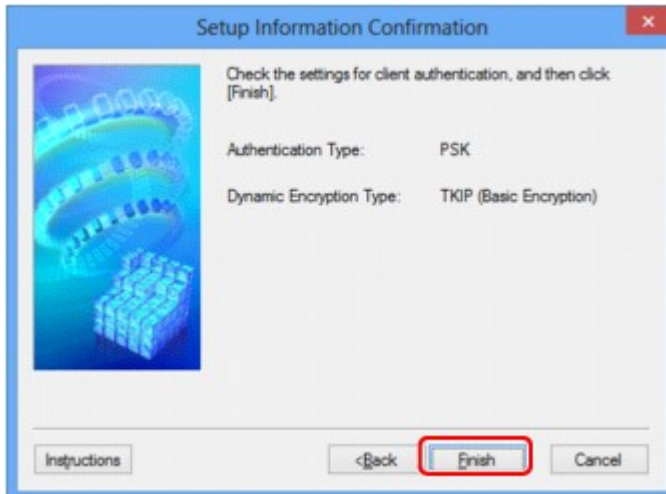

# Wired LAN Sheet

## ▶▶▶ Note

- This screen is not available depending on the printer you are using.

Allows you to set the printer with wired LAN connection.

To display the **Wired LAN** sheet, click the **Wired LAN** tab on the **Configuration** screen.

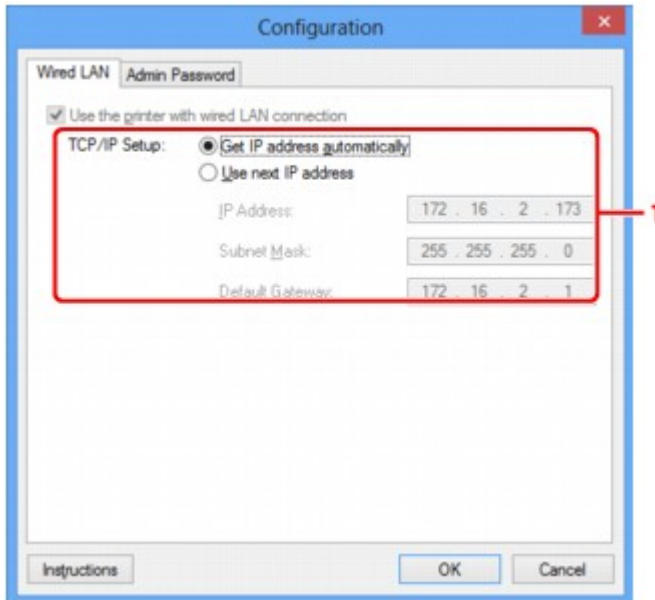

### 1. TCP/IP Setup:

Sets the IP address of the printer to be used over the LAN. Set a value appropriate for your network environment.

#### **Get IP address automatically**

Select this option to use an IP address automatically assigned by a DHCP server. DHCP server functionality must be enabled on your router.

#### **Use next IP address**

If no DHCP server functionality is available in your setup where you use the printer or you want to use a particular IP address, select this option to use a fixed IP address.

# Admin Password Sheet

Set a password for the printer to allow specific people to perform setup and configurations operation.

To display the **Admin Password** sheet, click the **Admin Password** tab on the **Configuration** screen.

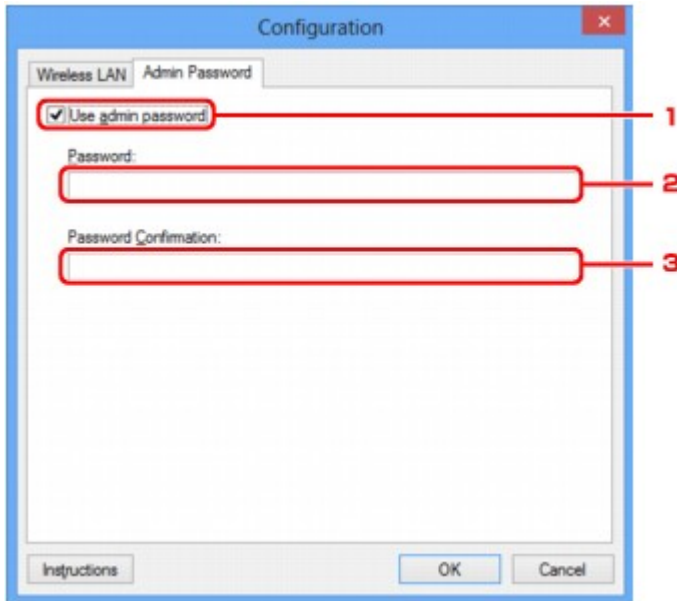

## 1. Use admin password

Set a password for the administrator with privileges to set up and change detailed options. To use this feature, select this check box and enter a password.

## 2. Password:

Enter the password to set.

## 3. Password Confirmation:

Enter the password again for confirmation.

# Network Information Screen

Display the network information that is set for the printers and the computers.

To display the **Network Information** screen, select **Network Information** from the **View** menu.

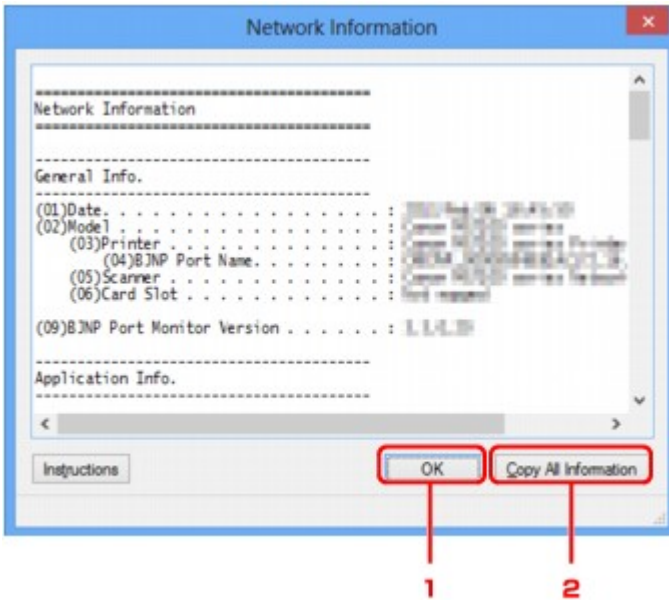

## 1. **OK**

Returns to the **Canon IJ Network Tool** screen.

## 2. **Copy All Information**

All network information displayed is copy to the clipboard.

# Access Control Sheet

## ▶▶▶ Note

- This screen is not available depending on the printer you are using.

You can register the MAC addresses or the IP addresses of computers or network devices to allow access.

To display the **Access Control** sheet, click the **Access Control** tab on the **Configuration** screen.

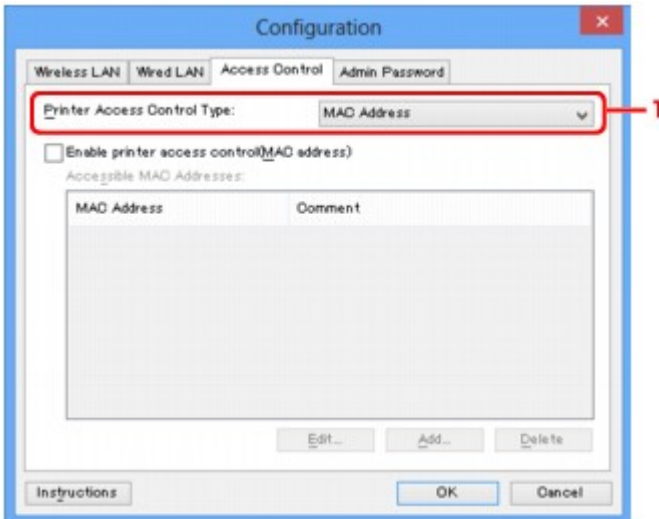

### 1. Printer Access Control Type:

Select the type of access control with which to limit access of computers or network devices to the printer over a network.

The setting items may differ depending on the choice of access control methods.

➔ [When Selecting MAC address](#)

➔ [When Selecting IP address](#)

### When Selecting MAC address

The accessible computers or network devices are specified by their MAC addresses. Computers or network devices whose MAC addresses appear on the list are allowed access.

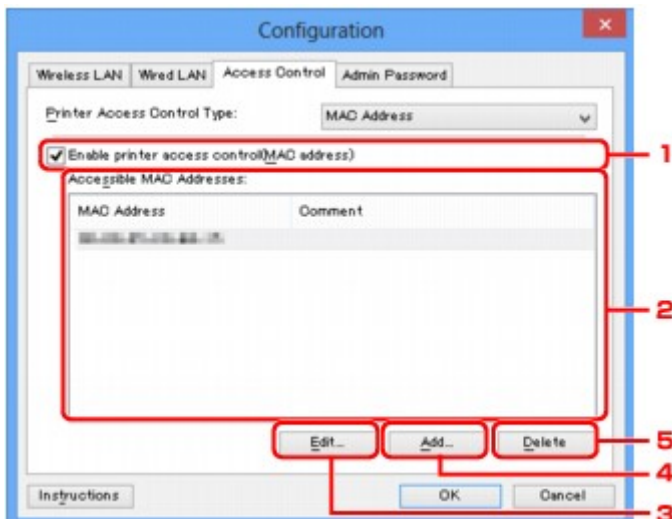

## 1. Enable printer access control(MAC address)

Select to enable access control to the printer by MAC address.

### »» Note

- The two types of access control (i.e., by MAC address and by IP address) can be enabled at the same time.

An access control type is enabled as long as the **Enable printer access control** check box is selected, regardless of the type currently displayed by selecting in **Printer Access Control Type**:

- When both access control types are enabled at the same time, a computer or a network device whose address is registered to either list will be allowed access to the printer.

## 2. Accessible MAC Addresses:

Shows the registered MAC addresses and any comments.

## 3. Edit...

The **Edit Accessible MAC Address** screen is displayed to edit the settings selected in **Accessible MAC Addresses**:

➔ [Edit Accessible MAC Address Screen/Add Accessible MAC Address Screen](#)

## 4. Add...

The **Add Accessible MAC Address** screen is displayed to register the MAC address of a computer or a network device from which to access the printer over the network.

### »» Important

- Add the MAC address of all computers or network devices within the network from which to access the printer. The printer cannot be accessed from a computer or a network device that is not on the list.

## 5. Delete

Deletes the selected MAC address from the list.

## When Selecting IP address

The accessible computers or network devices are specified by their IP addresses. Computers or network devices whose IP addresses appear on the list are allowed access.

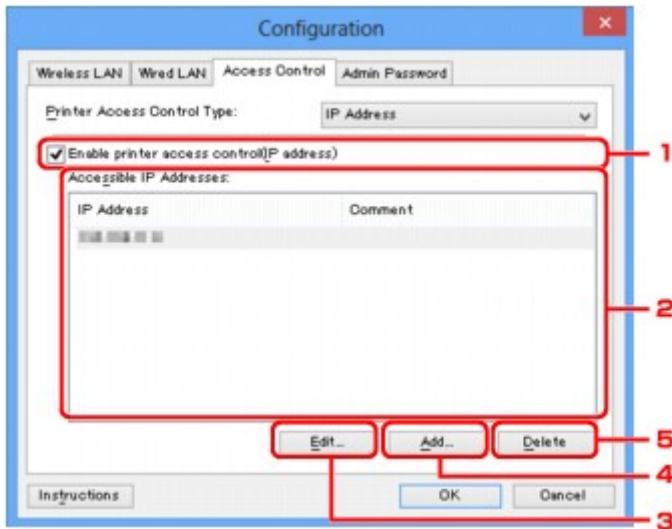

### 1. Enable printer access control(IP address)

Select to enable access control to the printer by IP address.

#### »»» Note

- The two types of access control (i.e., by MAC address and by IP address) can be enabled at the same time.
- An access control type is enabled as long as the **Enable printer access control** check box is selected, regardless of the type currently displayed by selecting in **Printer Access Control Type**.
- When both access control types are enabled at the same time, a computer or a network device whose address is registered to either list will be allowed access to the printer.

### 2. Accessible IP Addresses:

Shows the registered IP addresses and any comments.

### 3. Edit...

The **Edit Accessible IP Address** screen is displayed to edit the settings selected in **Accessible IP Addresses**.

➔ [Edit Accessible IP Address Screen/Add Accessible IP Address Screen](#)

### 4. Add...

The **Add Accessible IP Address** screen is displayed to register the IP address of a computer or a network device from which to access the printer over the network.

#### »»» Important

- Add the IP address of all computers or network devices within the network from which to access the printer. The printer cannot be accessed from a computer or a network device that is not on the list.
- Up to 16 IP addresses can be registered. IP addresses specified by Range Specification are counted as one address. Use Range Specification when you intend to register 17 or more IP addresses.



## 5. Delete

Deletes the selected IP address from the list.

# Edit Accessible MAC Address Screen/Add Accessible MAC Address Screen

## ▶▶▶ Note

- This screen is not available depending on the printer you are using.

The example screenshots in this section refer to the **Add Accessible MAC Address** Screen.



### 1. **MAC Address:**

Enter the MAC address of a computer or a network device to allow access.

### 2. **Comment:**

Optionally enter any information to identify the device, such as the name of the computer.

## ▶▶▶ Important

- Comments will be displayed only on the computer used to enter them.

# Edit Accessible IP Address Screen/Add Accessible IP Address Screen

## »» Note

- This screen is not available depending on the printer you are using.

The example screenshots in this section refer to the **Add Accessible IP Address** Screen.



### 1. Specification Method:

Select either **Single Address Specification** or **Range Specification** to add the IP address(es).

#### Single Address Specification

Specify each IP address separately.

#### Range Specification

Specify a range of successive IP addresses.

### 2. IP Address:

Enter the IP address of a computer or a network device to allow access when you selected **Single Address Specification** in **Specification Method**:

An IP address is expressed as four values ranging from 0 to 255.

#### Start IP Address:

Enter the first IP address in the range of addresses of the computers or network devices to allow access when you selected **Range Specification** in **Specification Method**:

An IP address is expressed as four values ranging from 0 to 255.

#### End IP Address:

Enter the last IP address in the range of addresses of the computers or network devices to allow access when you selected **Range Specification** in **Specification Method**:

An IP address is expressed as four values ranging from 0 to 255.

## »» Note

- The **Start IP Address**: must be a smaller value than the **End IP Address**:

### 3. Comment:

Optionally enter any information to identify the device, such as the name of the computer.

## »» Important

- Comments will be displayed only on the computer used to enter them.

## Other Screens of IJ Network Tool

- ➔ [Canon IJ Network Tool Screen](#)
- ➔ [Status Screen](#)
- ➔ [Connection Performance Measurement Screen](#)
- ➔ [Maintenance Screen](#)
- ➔ [Network Setup of the Card Slot Screen](#)
- ➔ [Associate Port Screen](#)
- ➔ [Network Information Screen](#)

# Canon IJ Network Tool Screen

This section describes the items and menus displayed on the **Canon IJ Network Tool** screen.

➔ [Items on the Canon IJ Network Tool Screen](#)

➔ [Canon IJ Network Tool Menus](#)

## Items on the Canon IJ Network Tool Screen

The following item is displayed on the **Canon IJ Network Tool** screen.

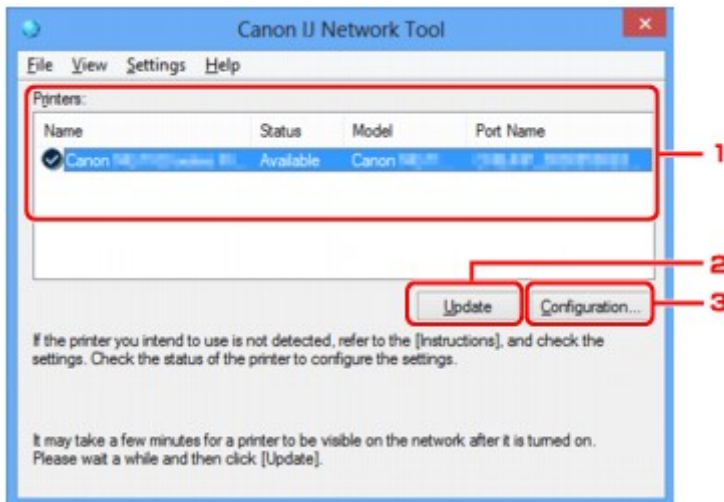

### 1. Printers:

The printer name, status, printer model name, and port name are displayed.

A check mark next to the printer in the **Name** list indicates it is set as the default printer.

Configuration changes are applied to the selected printer.

### 2. Update

Performs printer detection again. Click this button if the target printer is not displayed.

#### ▶▶▶ Important

- To change the printer's network settings using IJ Network Tool, it must be connected via a LAN.
- If **No Driver** is displayed for the name, associate the port with the printer.  
➔ [When the Printer Driver Is Not Associated with a Port](#)
- If **Not Found** is displayed for the status, check the followings:
  - The access point is turned on.
  - When using wired LAN, the LAN cable is connected properly.
- If the printer on a network is not detected, make sure that the printer is turned on, then click **Update**. It may take several minutes to detect printers. If the printer is not yet detected, connect the machine and the computer with a USB cable, then click **Update**.
- If the printer is being used from another computer, a screen is displayed informing you of this condition.

## ▶▶▶ Note

- This item has the same function as **Refresh** in the **View** menu.

### 3. Configuration...

Click to configure settings of the selected printer.

➔ [Configuration Screen](#)

## ▶▶▶ Note

- You cannot configure a printer that has the status **Not Found**.
- This item has the same function as **Configuration...** in the **Settings** menu.

## Canon IJ Network Tool Menus

The following menu is displayed from the **Canon IJ Network Tool** screen.

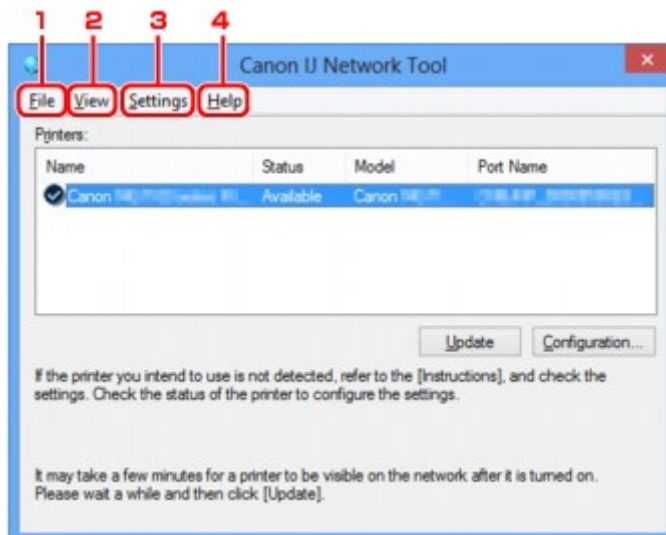

#### 1. File menu

##### Exit

Exits IJ Network Tool.

#### 2. View menu

##### Status

Displays the **Status** screen to confirm the printer connection status and wireless communication status.

➔ [Status Screen](#)

##### Refresh

Updates and displays the contents of **Printers:** on the **Canon IJ Network Tool** screen to the latest information.

## ▶▶▶ Important

- To change the printer's network settings using IJ Network Tool, it must be connected via a LAN.
- If **No Driver** is displayed for the name, associate the port with the printer.

➔ [When the Printer Driver Is Not Associated with a Port](#)

- If **Not Found** is displayed for the status, check the followings:
  - The access point is turned on.
  - When using wired LAN, the LAN cable is connected properly.
- If the printer on a network is not detected, make sure that the printer is turned on, then select **Refresh**. It may take several minutes to detect printers. If the printer is not yet detected, connect the machine and the computer with a USB cable, then select **Refresh**.
- If the printer is being used from another computer, a screen is displayed informing you of this condition.

### ▶▶▶ Note

- This item has the same function as **Update** in the **Canon IJ Network Tool** screen.

#### Network Information

Displays the **Network Information** screen to confirm the network settings of the printer and the computer.

➔ [Network Information Screen](#)

#### Display Warning Automatically

Enables or disables automatic display of the instruction screen.

When this menu is selected, the instruction screen is displayed if one or more ports are unavailable for printing.

### 3. Settings menu

#### Configuration...

Displays the **Configuration** screen to configure settings of the selected printer.

➔ [Configuration Screen](#)

### ▶▶▶ Note

- This item has the same function as **Configuration...** in the **Canon IJ Network Tool** screen.

#### Associate Port...

Displays the **Associate Port** screen and you can associate a port with the printer.

➔ [Associate Port Screen](#)

This menu is available when **No Driver** is displayed for the selected printer. Associating a port with the printer enables you to use it.

#### Maintenance...

Displays the **Maintenance** screen to revert the network settings of the printer to factory default and to mount the card slot as the network drive.

➔ [Maintenance Screen](#)

### 4. Help menu

#### Instructions

Displays this guide.

#### About

Displays the version of IJ Network Tool.

# Status Screen

You can check the printer status and connection performance.

To display the **Status** screen, select **Status** from the **View** menu.

## »» Note

- This screen is not available depending on the printer you are using.
- When using wired LAN, **Signal Strength:**, **Link Quality:** and **Advanced Measurement...** are not available.

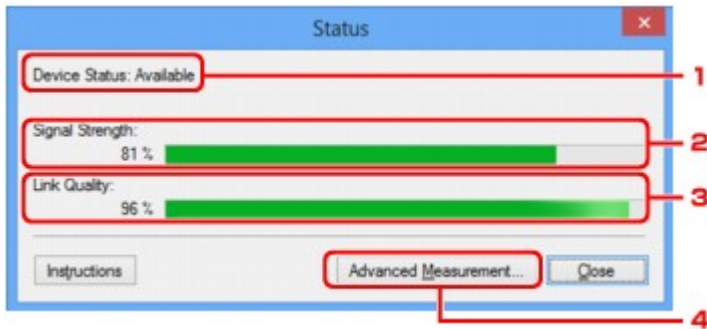

### 1. Device Status:

The device status is displayed as **Available** or **Unavailable**.

### 2. Signal Strength:

Indicates the strength of the signal received by the printer, ranging from 0% to 100%.

### 3. Link Quality:

Indicates the signal quality excluding the noise while communicating, ranging from 0% to 100%.

### 4. Advanced Measurement...

To examine the connection performance between the printer and the access point or between the printer and the computer.

When you click, the **Connection Performance Measurement** is displayed.

➡ [Connection Performance Measurement Screen](#)



# Connection Performance Measurement Screen

## ▶▶▶ Note

- This screen is not available depending on the printer you are using.

Displays to execute the connection performance measurement.

➔ [Connection Performance Measurement Screen \(Initial Screen\)](#)

➔ [Connection Performance Measurement Screen \(Completion Screen\)](#)

## Connection Performance Measurement Screen (Initial Screen)

Click **Next>** to start measurement.

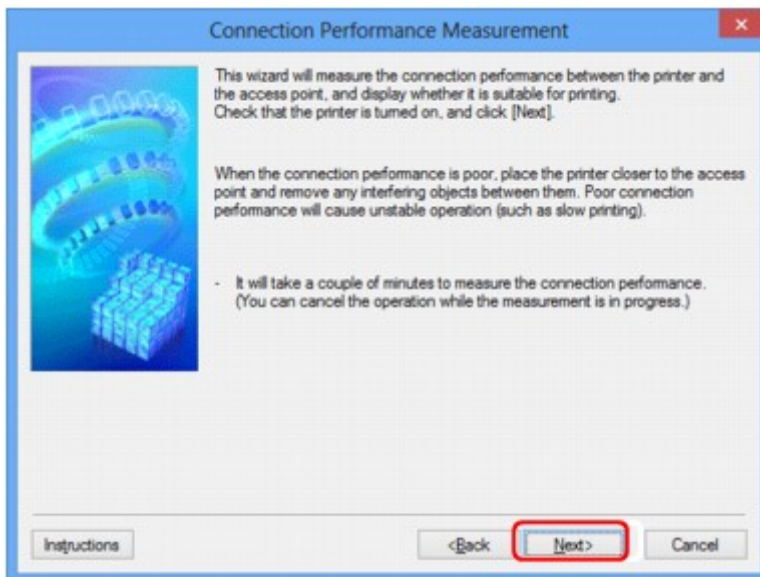

## Connection Performance Measurement Screen (Completion Screen)

Displays when the measurement is finished.

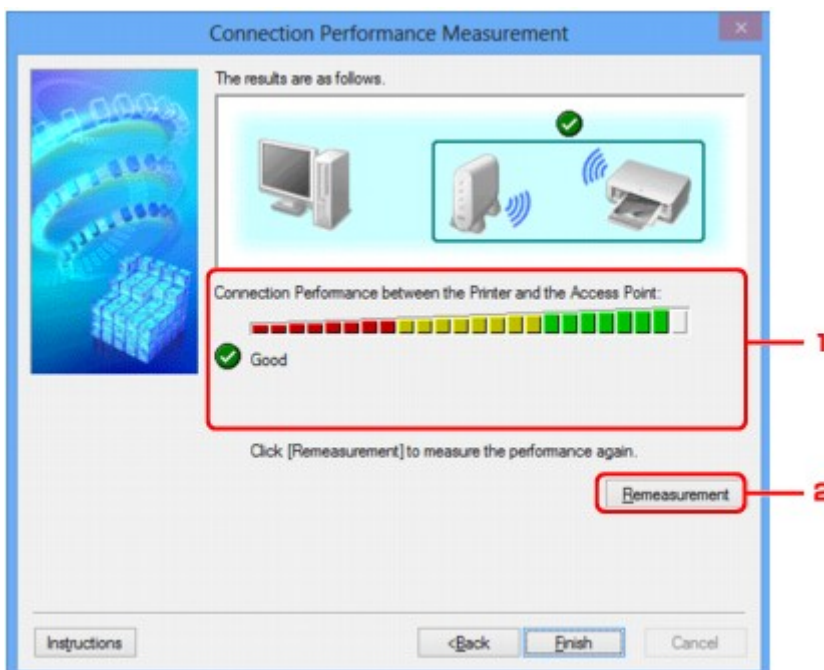

## 1. Connection Performance between the Printer and the Access Point:

A mark indicates the result of the connection performance measurement between the printer and the access point.



: Good connection performance



: Unstable connection performance



: Cannot connect



: Measurement is canceled, or cannot measure

## 2. Remeasurement

Measures the connection performance again.

### ▶▶▶ Note

- If any messages appear on **Overall Network Performance**:, move the machine and access point as instructed to improve the performance.

# Maintenance Screen

Displays to perform **Setting Initialization** and **Network Setup of the Card Slot**.

To display the **Maintenance** screen, select **Maintenance...** from the **Settings** menu.

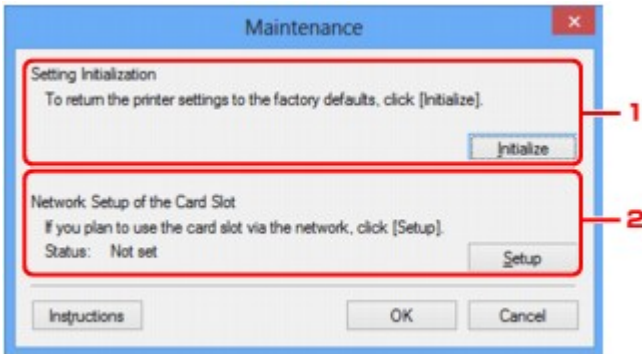

## 1. Setting Initialization

Reverts all the network settings of the printer to factory default. Click **Initialize** to display the **Initialize Settings** screen and click **Yes** to initialize the network settings of the printer. Do not turn off the printer during initialization. Click **OK** when initialization is complete.

Performing initialization when connected over wireless LAN will break the connection, so perform setup with the Setup CD-ROM or perform setup according to the instructions on our website.

## 2. Network Setup of the Card Slot

### ►►► Note

- This item is not available depending on the printer you are using.

**Status** displays whether the card slot is mapped as a network drive.

When you click, the **Network Setup of the Card Slot** is displayed.

➔ [Network Setup of the Card Slot Screen](#)

## Network Setup of the Card Slot Screen

### ▶▶▶ Note

- This screen is not available depending on the printer you are using.

Displays settings of the card slot and allows you to map a card slot on the network as a network drive on the computer.

Displays when you click **Setup** on the **Maintenance** screen.

➔ [Network Setup of the Card Slot Screen \(Setup Screen\)](#)

➔ [Network Setup of the Card Slot Screen \(Setup Failed Screen\)](#)

### ▶▶▶ Note

- You can change the network settings of the printer using IJ Network Tool with USB connection after initializing the LAN settings. To change the network settings using IJ Network Tool, activate the LAN settings in advance.

## Network Setup of the Card Slot Screen (Setup Screen)

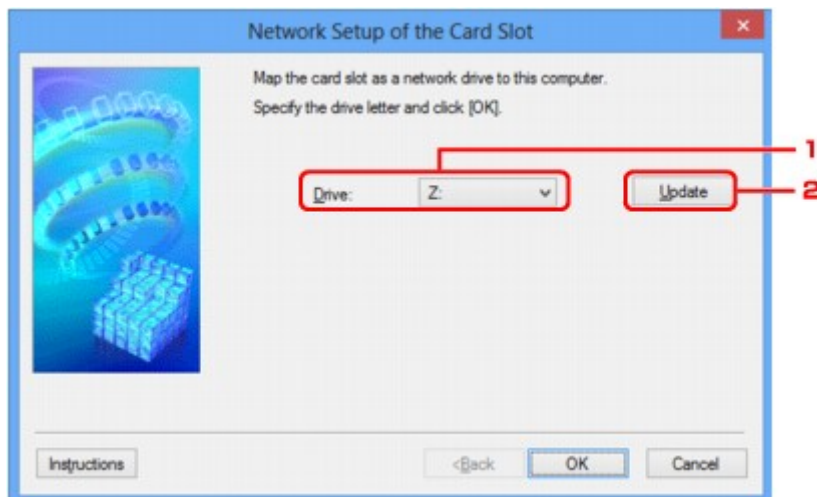

### 1. Drive:

Select the drive letter to assign to the network drive.

### 2. Update

Reloads the drive letters that are unassigned in **Computer (My Computer in Windows XP)** and displays them in the **Drive:** list.

## Network Setup of the Card Slot Screen (Setup Failed Screen)

Display when the network setup of the card slot is failed.

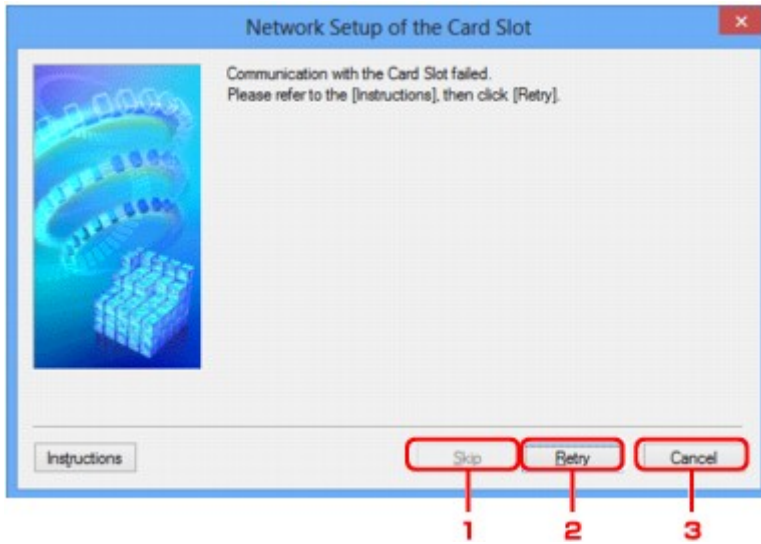

### 1. **Skip**

Completes the setup without mapping a network drive to the card slot.

### 2. **Retry**

Returns to **Network Setup of the Card Slot** screen and re-executes the network drive mapping.

### 3. **Cancel**

Cancels the card slot setup. When IJ Network Tool is running over LAN, the **Cancel** button is displayed grayed out and cannot be clicked.

# Associate Port Screen

Allows you to associate a created port with a printer driver.

Select the printer for which you want to change the association, then click **OK**.

## ▶▶▶ Note

- You cannot print with the printer unless the printer driver is associated with the port.

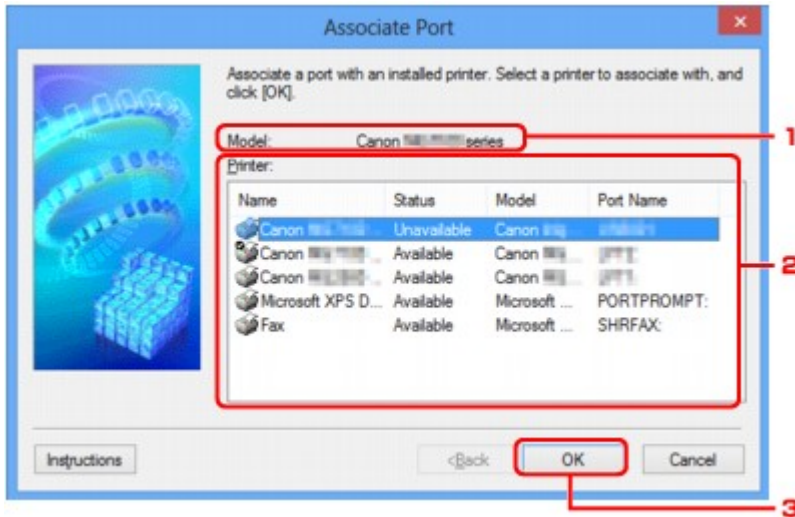

### 1. Model:

Displays the name of device specified as a destination port.

It is blank if the name of device is not detected.

### 2. Printer:

Displays the printer driver installed in the computer.

Select the printer for which you want to change the association.

### 3. OK

Performs association.

# Network Information Screen

Display the network information that is set for the printers and the computers.

To display the **Network Information** screen, select **Network Information** from the **View** menu.

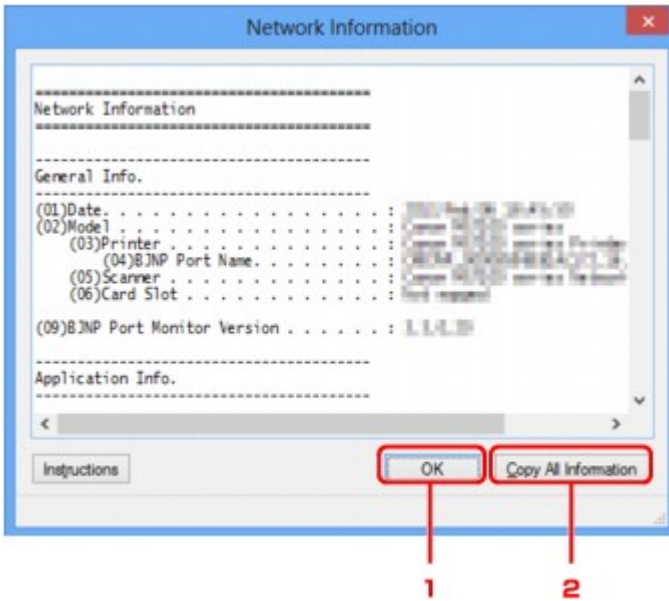

## 1. **OK**

Returns to the **Canon IJ Network Tool** screen.

## 2. **Copy All Information**

All network information displayed is copy to the clipboard.

## Appendix for Network Communication

- ➔ [Using the Card Slot over a Network](#)
- ➔ [When the Printer Driver Is Not Associated with a Port](#)
- ➔ [About Technical Terms](#)
- ➔ [Restrictions](#)
- ➔ [About Firewall](#)



# Using the Card Slot over a Network

## ►►► Note

- This screen is not available depending on the printer you are using.

➔ [Mounting the Card Slot as the Network Drive](#)

➔ [Restrictions on Card Slot Use over a Network](#)

## Mounting the Card Slot as the Network Drive

The card slot must be mounted to use it over a network.

To mount the card slot as the network drive, follow the procedure below.

1. Insert a memory card into the card slot of the machine.
2. [Start up IJ Network Tool.](#)
3. Select the machine in **Printers:**.
4. Select **Maintenance...** on the **Settings** menu.
5. Click **Setup**.

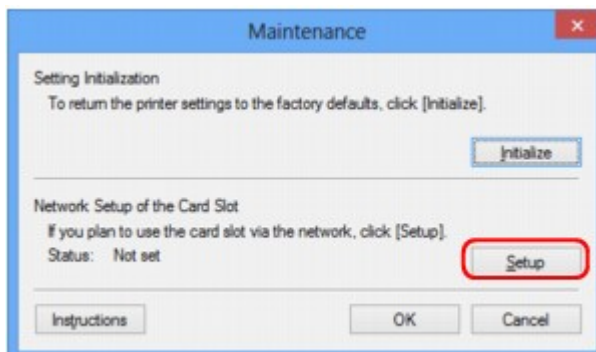

6. Specify the drive letter, then click **OK**.

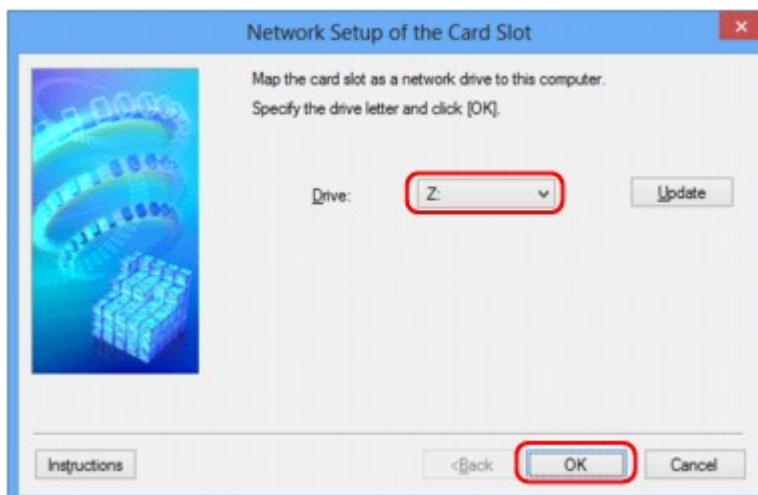

## 7. Make sure that the card slot is mounted.

When the card slot is mounted, the following icon appears on **Computer** (or **My Computer**).

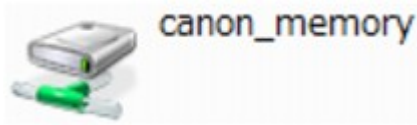

## Restrictions on Card Slot Use over a Network

- The card slot can be shared by multiple computers, if the machine is connected to a network. Multiple computers can read files from a memory card in the card slot at the same time. However, while one computer is writing a file into a memory card, other computers cannot access the same file.
- If your computer joins a domain, the card slot may not be mounted as the network drive.
- If you use the memory card stored the large size files or many files, a large amount of card access may be generated. In this case, the operation in the memory card may be impossible or slow. Operate after the **Access** lamp of the machine is lit.

- When you access the network drive for the card slot over the network, file names consisting of eight or less lowercase letters (not including its extension) may be shown in uppercase.

For example, a file name such as "abcdefg.doc" will be "ABCDEFGG.DOC", while a name such as "AbcdeFG.doc" will appear the same.

The file is not actually renamed, but merely appears to be changed.

- When you enable a memory card in the card slot of the machine to be writable only from a USB-connected computer, you cannot access the network drive of the card slot. On the other hand, when you enable it to be writable only from a LAN-connected computer, the card slot is not detected via USB. Make sure that the card slot setting is selected properly according to your connection method.

To read files from a memory card via USB and over a network, disable the function to write files to a memory card from a computer. You cannot write files to a memory card in either way with this setting.

- When you enable a memory card in the card slot of the machine to be writable only from a LAN-connected computer, you can write files to a memory card from a computer connected to a network. Note that it may increase the risk that the data on the memory card is infected by computer viruses or accessed illegally.

It is recommended to use the access control function of the machine or connect to the Internet via a router. For information on using a router, contact your Internet service provider or a network device manufacturer.

- If you write files to a memory card over a network when IJ Network Scanner Selector EX is not running, the Date Modified of the files may not be proper. Make sure to start up IJ Network Scanner Selector EX before you write files to a memory card over the network. For details, refer to "IJ Network Scanner Selector EX Menu and Setting Screen" from the HOME of your product's *Online Manual*.

## When the Printer Driver Is Not Associated with a Port

If **No Driver** is displayed for the printer's name on the **Canon IJ Network Tool** screen, the printer driver is not associated with a created port.

To associate a port with a printer driver, follow the procedure below.

1. [Start up IJ Network Tool.](#)
2. Select the printer displayed as **No Driver** on **Name**.
3. Select **Associate Port...** on the **Settings** menu.

The **Associate Port** screen is displayed.

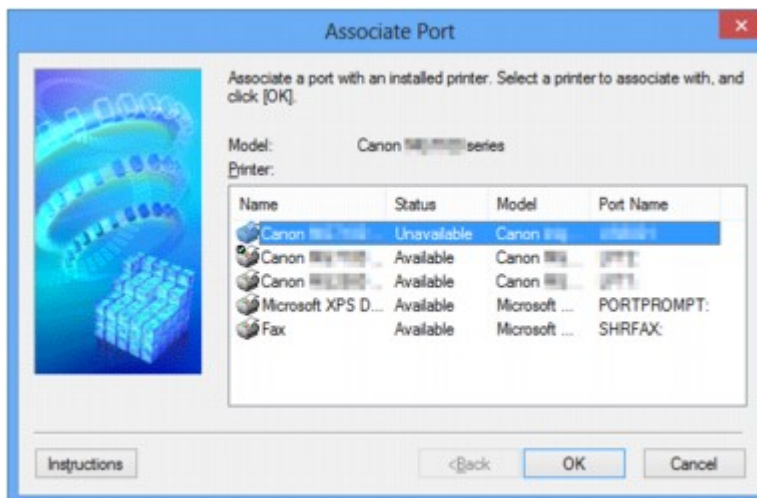

4. Select a printer to associate with a port.

The list of the printers that the printer driver is installed is displayed at **Printer:** on the **Associate Port** screen. Select a printer to associate with a created port.

5. Click **OK**.

# About Technical Terms

In this section, technical terms used in the manual are explained.

➡ [A](#)

➡ [B](#)

➡ [C](#)

➡ [D](#)

➡ [E](#)

➡ [I](#)

➡ [K](#)

➡ [L](#)

➡ [M](#)

➡ [O](#)

➡ [P](#)

➡ [R](#)

➡ [S](#)

➡ [T](#)

➡ [U](#)

➡ [W](#)

## A

- **Access Point**

A wireless transceiver or base station that receives information from wireless clients/the machine and rebroadcasts it. Required in an infrastructure network.

- **Ad-hoc**

Client computer and machine setting where wireless communication occurs on a peer-to-peer basis, i.e., all clients in with the same SSID/network name communicate directly with each other. No access point is required. This machine does not support ad-hoc communication.

- **Admin Password**

Administration password in IJ Network Tool to restrict access to network users. It must be entered to access the printer and change printer settings.

When the printer's network settings are factory default, the admin password does not have to be entered.

- **AES**

An encryption method. It is optional for WPA. Strong cryptographic algorithm adopted within U.S. government organizations for information processing.

- **Authentication Method**

The method that an access point uses to authenticate a printer through a wireless LAN. The methods are agreeable each other.

When using WEP as an encryption method, the authentication method is able to fix to **Open System** or **Shared Key**.

For WPA/WPA2, authentication method is PSK.

- **Auto**

The printer automatically changes its authentication method to match the access point.

- **Open System**

In this authentication method, the communication partner is authenticated without using WEP key even if **Use WEP** is selected.

- **Shared Key**

In this authentication method, the communication partner is authenticated using the WEP key that was set for encryption.

## **B**

- **Bonjour**

A service built into Mac OS X operating system to detect the connectable devices on a network automatically.

## **C**

- **Channel**

Frequency channel for wireless communication. In the infrastructure mode, the channel is automatically adjusted to match that set to the access point. This machine supports channels 1 to 13. Note that the number of channels that can be used for your wireless LAN varies depending on the region or country.

## **D**

- **Default Gateway**

A relay device to connect to another network such as a router or a computer.

- **DHCP server functionality**

The router or the access point assigns an IP address automatically whenever the printer or the personal computer on a network starts up.

- **DNS server**

A server that converts device names into IP addresses. When specifying IP addresses manually, specify the addresses of both a primary and a secondary server.

## **F**

- **Firewall**

It is a system that prevents an unlawful computer access in the network. To prevent, you can use the firewall function of a broadband router, the security software installed in the computer, or operation system for computer.

## I

- **IEEE 802.11b**

International standard for wireless LAN using the 2.4 GHz frequency range with a throughput of up to 11 Mbps.

- **IEEE 802.11g**

International standard for wireless LAN using the 2.4 GHz frequency range with a throughput of up to 54 Mbps. Compatible with 802.11b.

- **IEEE 802.11n**

International standard for wireless LAN using the 2.4 GHz and 5 GHz frequency ranges. Even when using two or more antennas simultaneously or obtaining a bigger transfer rate than before by using multiple communication channels at the same time, the transmission speed may be influenced by the connected apparatus.

At the maximum transfer rate of 600 Mbps, it is possible to communicate with multiple computer terminals within a dozen or so metre radius.

Compatible with 802.11b and 802.11g.

- **Infrastructure**

Client computer and machine setup where all wireless communications pass through an access point.

- **IP Address**

A unique number with four parts separated by dots. Every network device that is connected to the Internet has an IP address. Example: 192.168.0.1

An IP address is usually assigned by an access point or a DHCP server of the router automatically.

- **IPv4/IPv6**

They are internetwork-layer protocol used on the internet. IPv4 uses 32-bit addresses and IPv6 uses 128-bit addresses.

## K

- **Key Format**

Select either **ASCII** or **Hex** as the WEP key format. The character that can be used for the WEP key differs depending on the selected key formats.

- ASCII

Specify with a 5 or 13-character string that can include alphanumeric and underscore "\_" characters. It is case-sensitive.

- Hex

Specify a 10-digit or 26-digit string that can contain hexadecimal (0 to 9, A to F, and a to f).

- **Key Length**

Length of the WEP key. Select either 64 bits or 128 bits. Longer key length allows you to set a more complex WEP key.

## L

- **Link Quality**

The status of connection between the access point and the printer excluding noise (interference) is indicated with a value from 0 to 100%.

- **LPR**

A platform-independent printing protocol used in TCP/IP networks. It is not supported bidirectional communication.

## M

- **MAC Address**

Also known as the physical address. A unique and permanent hardware identifier that is assigned to network devices by its manufacturer. MAC addresses are 48 bits long and are written as a hexadecimal number separated by colons, i.e., 11:22:33:44:55:66.

## O

- **Operation Status**

Indicates the status on whether the printer can be used.

## P

- **Proxy server**

A server that links a LAN-connected computer to the Internet. When using a proxy server, specify the address and the port number of the proxy server.

- **PSK**

An encryption method employed by WPA/WPA2.

## R

- **Router**

A relay device to connect to another network.

## S

- **Signal Strength**

The strength of the signal received by the printer from the access point is indicated with a value from 0 to 100%.

- **SSID**

Unique label for wireless LAN. It is often represented such as a network name or an access point name.

SSID distinguishes one wireless LAN from another to prevent interference.

The printer and all clients on a wireless LAN must use the same SSID in order to communicate with each other. The SSID can be up to 32 characters long, and is made up of alphanumeric characters. The SSID may also be referred to by its network name.

- **Stealth**

In the stealth mode, an access point hides itself by not broadcasting its SSID. The client must specify the SSID set to the access point to detect it.

- **Subnet Mask**

IP address has two components, the network address and the host address. Subnet Mask used to calculate the Subnet Mask address from the IP address. A Subnet Mask is usually assigned by an access point or a DHCP server of the router automatically.

Example:

IP Address: 192.168.127.123

Subnet Mask: 255.255.255.0

Subnet Mask Address: 192.168.127.0

## T

- **TCP/IP**

Suite of communications protocols used to connect hosts on the Internet or the LAN. This protocol allows different terminals to communicate with each other.

- **TKIP**

An encryption protocol employed by WPA/WPA2.

## U

- **USB**

Serial interface designed to enable you to "hot-swap" devices, i.e., by plugging and unplugging them without turning off the power.

## W

- **WCN (Windows Connect Now)**

Users running Windows Vista or later can obtain the setting information directly via wireless network (WCN-NET).

- **WEP/WEP Key**

An encryption method employed by IEEE 802.11. Shared security key used to encrypt and decrypt data sent over wireless networks. This printer supports key length of 64 bits or 128 bits, key format of ASCII code or Hexadecimal, and key number of 1 to 4.

- **Wi-Fi**

International association that certifies interoperability of wireless LAN products based on the IEEE 802.11 specification.



This machine is a Wi-Fi authorized product.

- **Wireless LAN**

A network that, instead of being connected by physical wires, is connected by a wireless technology, such as Wi-Fi.

- **WPA**

Security framework announced by the Wi-Fi Alliance in October 2002. The security has been strengthened more than WEP.

- Authentication

WPA defines the following authentication methods: PSK that can be used without an authentication server, plus WPA-802.1x that do require an authentication server.

This machine supports WPA-PSK.

- Passphrase

This encrypted key is used to perform WPA-PSK authentication.

The passphrase should be a string of 8 to 63 alphanumeric characters or a 64-digit hexadecimal value.

- **WPA2**

Security framework released by the Wi-Fi Alliance in September 2004 as a later version of WPA. Provides a stronger encryption mechanism through Advanced Encryption Standard (AES).

- Authentication

WPA2 defines the following authentication methods: PSK that can be used without an authentication server, plus WPA2-802.1x that do require an authentication server.

This machine supports WPA2-PSK.

- Passphrase

This encrypted key is used to perform WPA2-PSK authentication.

The passphrase should be a string of 8 to 63 alphanumeric characters or a 64-digit hexadecimal value.

- **WPS (Wi-Fi Protected Setup)**

WPS is a standard for easy and secure establishment of a wireless network.

There are 2 primary methods used in the Wi-Fi Protected Setup:

PIN entry: a mandatory method of setup for all WPS certified devices

Push button configuration (PBC): an actual push button on the hardware or through a simulated push button in the software.

## **Restrictions**

If you use a printer over the wireless LAN, the printer may recognize nearby wireless systems, you should set a network key (WEP, WPA, or WPA2) to the access point to encrypt wireless transmission. Wireless communication with a product that does not comply with the Wi-Fi standard cannot be guaranteed.

Connecting with too many computers may affect the printer performance, such as printing speed.

# About Firewall

A firewall is a function of the security software installed in the computer or operation system for computer, and is a system that is designed to prevent unauthorized access to a network.

## Precautions When a Firewall Function is Enabled

- A firewall function may limit communications between a printer and a computer. This may disable printer setup and communications.
- During the printer setup, you may be prompted to enable or disable communications, depending on the firewall function of the security software or operation system. If so, choose to enable communications.
- When using IJ Network Tool, you may be prompted to enable or disable communications, depending on the firewall function of the security software. If so, choose to enable communications.
- If you cannot set up the printer, temporarily disable the firewall function of the security software or operation system.

### ►► Important

- If you disabled the firewall function, disconnect your network from the Internet.

- Some applications (like the network configuration software) override firewall settings. Check the application's settings beforehand.
- If the printer you use is set to **Get IP address automatically**, the IP address changes every time the printer connects to the network. This may disable printer setup and communications, depending on the firewall settings. In this case, either change the firewall settings or assign a fixed IP address to the printer. An IP address can be set using IJ Network Tool.

➡ [Changing the Settings in the Wireless LAN Sheet](#)

➡ [Changing the Settings in the Wired LAN Sheet](#)

When assigning a fixed IP address to the printer, you will need to specify an IP address with which the computer can communicate.

### ►► Note

- For the operation system firewall settings or the security software firewall settings, refer to the instruction manual of the computer or software, or contact its manufacturer.

## Tips for Ensuring Optimal Printing Quality

- [Useful Information about Ink](#)
- [Key Points to Successful Printing](#)
- [Be Sure to Make Paper Settings after Loading Paper](#)
- [Canceling a Print Job](#)
- [Key to Enjoying Consistent Printing Quality](#)
- [Precautions for Safe Transport of the Machine](#)

## **Useful Information about Ink**

### **How is ink used for various purposes other than printing?**

Ink may be used for purposes other than printing. Ink is not only used for printing, but also for cleaning the print head to maintain the optimal printing quality.

The machine has the function to automatically clean the ink jet nozzles to prevent clogging. In the cleaning procedure, ink is pumped out from the nozzles. Used ink for nozzle cleaning is limited to a small amount.

### **Does black-and-white printing use color ink?**

Black-and-white printing may use ink other than black ink depending on the type of printing paper or the settings of the printer driver. So, color ink is consumed even when printing in black-and-white.

## Key Points to Successful Printing

### Check the machine status before printing!

- Is the print head OK?

If a print head nozzle is clogged, print will be faint and papers will be wasted. Print the nozzle check pattern to check the print head.

➡ [Maintenance Procedure](#)

- Is the inside of the machine smeared with ink?

After printing large quantities of paper or performing borderless printing, the area where papers go through may get smeared with ink. Clean the inside of your machine with Bottom Plate Cleaning.

➡ [Cleaning the Inside of the Machine \(Bottom Plate Cleaning\)](#)

### Check how to load the paper correctly!

- Is the paper loaded in the correct orientation?

To load paper in the front tray, load paper WITH THE PRINTING SIDE FACING DOWN.

➡ [Loading Paper](#)

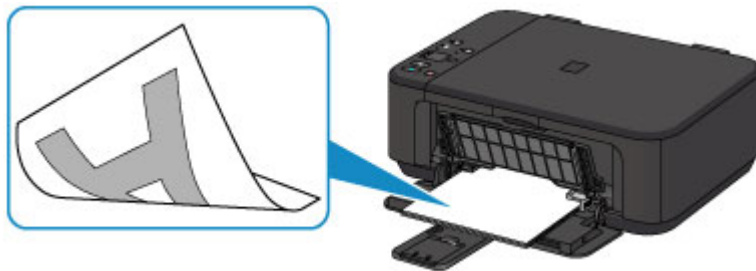

- Is the paper curled?

The curled paper causes paper jam. Flatten the curled paper, then reload it.

➡ "Load the paper after correcting its curl." in Paper Is Smudged/Printed Surface Is Scratched.

## Be Sure to Make Paper Settings after Loading Paper

If the media type setting is not the one for the loaded paper, printing results may not be satisfactory. After loading paper, be sure to select the appropriate media type setting for the loaded paper.

➡ Print Results Not Satisfactory

There are various types of paper: paper with special coating on the surface for printing photos with optimal quality and paper suitable for documents.

Each media type has specific preset settings, such as how ink is used and sprayed, distance from nozzles, etc., so that you can print on that type with optimal image quality.

This allows you to print with the settings best suited for the loaded media type just by selecting that media type.

## Canceling a Print Job

### Never press the ON button!

If you press the **ON** button while printing is in progress, the print data sent from the computer queues in the machine and you may not be able to continue to print.

Press the **Stop** button to cancel printing.



## Key to Enjoying Consistent Printing Quality

The key to printing with the optimal printing quality is to prevent the print head from drying or clogging. Always observe the following rules for optimal printing quality.

### **Never disconnect the power plug until the power is turned off!**

If you press the **ON** button to turn off the power, the machine caps the print head (nozzles) automatically to prevent from drying. If you disconnect the power plug from the wall outlet before the power is turned off (while the **ON** lamp is lit or flashing), the print head will not be capped properly and this will cause drying or clogging.

When disconnecting the power plug, make sure that the **ON** lamp is not lit.

➔ [Notice for Unplugging the Power Cord](#)

### **Print periodically!**

Just as the tip of a felt pen becomes dry and unusable if it has not been used for a long time, even if it is capped, the print head too, may become dried or clogged if the machine has not been used for a long time.

We recommend you to use the machine at least once a month.

### **▶▶▶ Note**

- 
- Depending on the type of paper, ink may blur if you trace the printed area with a highlight pen or paint-stick, or bleed if water or sweat comes in contact with the printed area.
-

## Precautions for Safe Transport of the Machine

When relocating the machine, make sure of the following.

### ▶▶▶ Important

#### When sending the machine for repair

- Pack the machine in a sturdy box so that it is placed with its bottom facing down, using sufficient protective material to ensure safe transport.
- With the FINE cartridge left installed in the machine, press the **ON** button to turn off the power. This allows the machine to automatically cap the print head, thus preventing it from drying.
- After packing, do not tilt the box containing the machine or turn it on its side or upside down. Doing so may cause the ink to leak during transport and cause damage to the machine.
- When a shipping agent is handling transport of the machine, have its box marked "THIS SIDE UP" to keep the machine with its bottom facing down. Mark also with "FRAGILE" or "HANDLE WITH CARE".

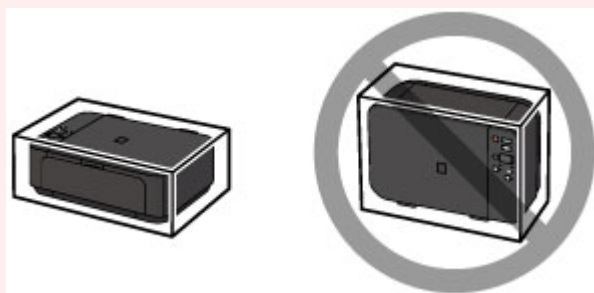

1. Turn the machine off.
2. Confirm that the **ON** lamp is off and unplug the machine.

➡ [Notice for Unplugging the Power Cord](#)

### ▶▶▶ Important

- Do not unplug the machine while the **ON** lamp is lit or flashing, as it may cause malfunction or damage to the machine, making the machine unable to print.

3. Retract the paper output support, then close the paper output tray. Retract the paper support with the output tray extension closed.
4. Close the front cover.
5. Disconnect the printer cable from the computer and from the machine, then disconnect the power plug from the machine.
6. Use adhesive tape to secure all the covers on the machine to keep them from opening during transportation. Then pack the machine in the plastic bag.
7. Attach the protective material to the machine when packing the machine in the box.

## Legal Limitations on Use of Your Product and Use of Images

It may be unlawful to make copies of, scan, print, or use reproductions of the following documents.

The list provided is non-exhaustive. When in doubt, check with a legal representative in your jurisdiction.

- Paper money
- Money orders
- Certificates of deposit
- Postage stamps (canceled or uncanceled)
- Identifying badges or insignias
- Selective service or draft papers
- Checks or drafts issued by governmental agencies
- Motor vehicle licenses and certificates of title
- Traveler's checks
- Food stamps
- Passports
- Immigration papers
- Internal revenue stamps (canceled or uncanceled)
- Bonds or other certificates of indebtedness
- Stock certificates
- Copyrighted works/works of art without permission of copyright owner

# Specifications

## General Specifications

|                                  |   |
|----------------------------------|---|
| <b>Printing resolution (dpi)</b> | 4800* (horizontal) x 1200 (vertical)<br>* Ink droplets can be placed with a pitch of 1/4800 inch at minimum.  |
| <b>Interface</b>                 | <b>USB Port:</b><br>Hi-Speed USB *1<br><b>LAN Port:</b><br>Wireless LAN: IEEE802.11n/IEEE802.11g/IEEE802.11b *2<br>*1 A computer that complies with Hi-Speed USB standard is required. Since the Hi-Speed USB interface is fully upwardly compatible with USB 1.1, it can be used at USB 1.1.<br>*2 Setup possible through WPS (Wi-Fi Protected Setup), WCN (Windows Connect Now) or Cableless setup. |
| <b>Print width</b>               | 8 inches/203.2 mm<br>(for Borderless Printing: 8.5 inches/216 mm)   |
| <b>Operating environment</b>     | <b>Temperature:</b> 41 to 95 °F (5 to 35 °C)<br><b>Humidity:</b> 10 to 90 % RH (no condensation)  |
| <b>Storage environment</b>       | <b>Temperature:</b> 32 to 104 °F (0 to 40 °C)<br><b>Humidity:</b> 5 to 95 % RH (no condensation)  |
| <b>Power supply</b>              | AC 100-240 V, 50/60 Hz  |
| <b>Power consumption</b>         | <b>Printing (Copy):</b> Approx. 16 W *1<br><b>Standby (minimum):</b> Approx. 1.7 W *1*2<br><b>OFF:</b> Approx. 0.3 W<br>*1 Wireless LAN is active.<br>*2 The wait time for standby cannot be changed.   |
| <b>External dimensions</b>       | Approx. 17.7 (W) x 12 (D) x 6 (H) inches<br>Approx. 449 (W) x 304 (D) x 152 (H) mm<br>* With the Front Cover retracted.   |
| <b>Weight</b>                    | Approx. 11.9 lb (Approx. 5.4 kg)<br>* With the FINE Cartridges installed.   |
| <b>Canon FINE Cartridge</b>      | Total 1792 nozzles (BK 640 nozzles, C/M/Y each 384 nozzles)   |

## Copy Specifications

|                              |               |
|------------------------------|---------------|
| <b>Multiple copy</b>         | max. 21 pages |
| <b>Reduction/Enlargement</b> | Fit-to-page   |

## Scan Specifications

|                                 |   |
|---------------------------------|---|
| <b>Scanner driver</b>           | <b>Windows:</b> TWAIN 1.9 Specification, WIA<br><b>Mac OS:</b> ICA  |
| <b>Maximum scanning size</b>    | A4/Letter, 8.5" x 11.7"/216 x 297 mm  |
| <b>Scanning resolution</b>      | <b>Optical resolution (horizontal x vertical) max:</b> 1200 x 2400 dpi *1<br><b>Interpolated resolution max:</b> 19200 x 19200 dpi *2<br>*1 Optical Resolution represents the maximum sampling rate based on ISO 14473.<br>*2 Increasing the scanning resolution will limit the maximum possible scanning area. |
| <b>Gradation (Input/Output)</b> | <b>Gray:</b> 16 bit/8 bit<br><b>Color:</b> 48 bit/24 bit (RGB each 16 bit/8 bit)  |

## Network Specifications

|                               |  |
|-------------------------------|--|
| <b>Communication protocol</b> | TCP/IP   |
| <b>Wireless LAN</b>           | <p><b>Supported Standards:</b> IEEE802.11n/IEEE802.11g/IEEE802.11b</p> <p><b>Frequency bandwidth:</b> 2.4 GHz</p> <p><b>Channel:</b> 1-11 or 1-13</p> <p>* Frequency bandwidth and available channels differ depending on country or region.</p> <p><b>Transfer speed (Standard value):</b></p> <p>IEEE802.11n: max. 150 Mbps</p> <p>IEEE802.11g: max. 54 Mbps</p> <p>IEEE802.11b: max. 11 Mbps</p> <p>* These values are a theoretical maximum transmission speed between the printer and an equivalent network device, and do not indicate the actual transmission speed obtained.</p> <p><b>Communication distance:</b> Indoors 164 feet/50 m</p> <p>* Effective range varies depending on the installation environment and location.</p> <p><b>Security:</b></p> <p>WEP (64/128 bits)</p> <p>WPA-PSK (TKIP/AES)</p> <p>WPA2-PSK (TKIP/AES)</p> <p><b>Setup:</b></p> <p>WPS (Push button configuration/PIN code method)</p> <p>WCN (WCN-NET)</p> <p>Cableless setup</p> <p><b>Other Features:</b> Administration password</p> |

## Minimum System Requirements

Conform to the operating system's requirements when higher than those given here.

### Windows

|                         |  |
|-------------------------|--|
| <b>Operating System</b> | Windows 8<br>Windows 7, Windows 7 SP1<br>Windows Vista SP1, Windows Vista SP2<br>Windows XP SP3 32-bit only                |
| <b>Browser</b>          | Internet Explorer 8 or later   |
| <b>Hard Disk Space</b>  | 3 GB<br>Note: For bundled software installation.<br>The necessary amount of hard disk space may be changed without notice. |
| <b>Display</b>          | XGA 1024 x 768   |

### Mac OS

|                         |  |
|-------------------------|--|
| <b>Operating System</b> | Mac OS X v10.6.8 or later  |
| <b>Browser</b>          | Safari 5 or later  |
| <b>Hard Disk Space</b>  | 1.5 GB<br>Note: For bundled software installation.<br>The necessary amount of hard disk space may be changed without notice. |
| <b>Display</b>          | XGA 1024 x 768   |

## Other Supported OS

Some functions may not be available with each OS. Refer to the manual or the Canon web site for details on operation with iOS, Android, and Windows RT.

## Mobile Printing Capability

### Apple AirPrint

### Google Cloud Print

- An internet connection is required to view the *Online Manual*.
- Windows: Operation can only be guaranteed on a computer with Windows 8, Windows 7, Windows Vista or Windows XP pre-installed.
- Windows: A CD-ROM Drive or internet connection is required during software installation.
- Windows: Internet Explorer 8, 9 or 10 is required to install Easy-WebPrint EX. Easy-WebPrint EX for Internet Explorer 10 can be downloaded from the Canon web site.
- Windows: Some functions may not be available with Windows Media Center.
- Windows: .NET Framework 4 or 4.5 must be installed to use the Windows software.
- Windows: XPS Essentials Pack is required to print on Windows XP.
- Mac OS: Hard Disk must be formatted as Mac OS Extended (Journaled) or Mac OS Extended.
- Mac OS: For Mac OS, an internet connection is required during software installation.
- Windows: The TWAIN driver (ScanGear) is based on the TWAIN 1.9 Specification and requires the Data Source Manager bundled with the operating system.

Specifications are subject to change without notice.