



MultiPASS™ MP730
MultiPASS™ MP700

User's Guide



Copyright

Copyright © 2003 by Canon Inc. All rights reserved. No part of this publication may be reproduced, transmitted, transcribed, stored in a retrieval system, or translated into any language or computer language in any form or by any means, electronic, mechanical, magnetic, optical, chemical, manual, or otherwise, without the prior written permission of Canon Inc.

Trademarks

Canon and BJ are registered trademarks. BCI, MultiPASS, UHQ, and ScanGear are trademarks of Canon Inc.

All other product and brand names are registered trademarks, trademarks or service marks of their respective owners.



As an ENERGY STAR® Partner, Canon Inc. has determined that this product meets the ENERGY STAR® guidelines for energy efficiency.



Super G3 is a phrase used to describe the new generation of fax machines that use ITU-T V.34 standard 33.6 Kbps* modems. Super G3 High Speed Fax machines allow transmission time of approximately 3 seconds* per page which results in reduced telephone line charges.

* Approximately 3 seconds per page fax transmission time based on ITU-T No. 1 Chart (Standard Mode) at 33.6 Kbps modem speed. The Public Switched Telephone Network (PSTN) currently supports 28.8 Kbps modem speeds or lower, depending on telephone line conditions.

► How to use the documentation provided

START HERE

 **Set-Up Sheet**

Be sure to read this sheet first!

This sheet includes instructions for setting up your machine and getting it ready for use. Follow all steps in this sheet before using your machine.

 **Quick Reference Guide**

After following instructions in the Set-Up Sheet, we recommend you read this guide to familiarize yourself with the basic operation of all functions of your machine.

 **User's Guide (This guide)**

This guide, included as a PDF file in the MultiPASS MP730/700 Setup CD-ROM, includes instructions on functions that can be performed directly from your machine as well as detailed information on memory cards. Refer to this guide for in-depth instructions not included in the Quick Reference Guide, or if you want to learn more about advanced features.

 **Software Guide**





This guide, included as a PDF file in the MultiPASS MP730/700 Setup CD-ROM, includes comprehensive instructions on using the software. Refer to this guide for full instructions on printing, scanning, and  faxing from your computer.

NOTE

- In addition to the above documentation, you can also refer to the online help in the software for online information about a window or dialog box, and for step by step instructions on performing software tasks. To access the online help, select or click [Help] in the software.

► Type conventions

Please read the list below of symbols, terms, and abbreviations used in this guide.

 WARNING	Indicates a warning concerning operations that may lead to death or injury to persons if not performed correctly. In order to use the machine safely, always pay attention to these warnings.
 CAUTION	Indicates a caution concerning operations that may lead to injury to persons or damage to property if not performed correctly. In order to use the machine safely, always pay attention to these cautions.
 IMPORTANT	Indicates operational warnings and restrictions. Be certain to read these items to operate the machine correctly, and to avoid damage to the machine.
 NOTE	Indicates notes for operation or additional explanations. Reading these is highly recommended.
 Fax Model	Indicates information exclusively for the MultiPASS MP730 model.
(→ p. n-nn)	Indicates a page number where additional information can be found.
→ <i>Set-Up Sheet</i>	Refer to the Set-Up Sheet for more details.
→ <i>Quick Reference Guide</i>	Refer to the Quick Reference Guide for more details.
→ <i>Software Guide</i>	Refer to the Software Guide (included in the CD-ROM) for more details.
machine	General term used to represent the MultiPASS MP730 or MultiPASS MP700.
default	A setting that remains in effect unless you change it.
document	The original sheet(s) of paper you copy or scan with the machine.
menu	A list of settings from which you select an item to set up or change. A menu has a title which appears in the LCD.
[key name]	Text enclosed in these brackets indicate a key name or item on the computer you have to click, double-click, or point to.
<message>	Text enclosed in these brackets indicate an LCD message.
click, double-click	Term used to select or choose a command or option on your computer, generally with a mouse.
<i>Fax model only:</i>	
fax or document	The original sheet(s) of paper you send or receive with the machine.
transaction number	A four-digit number assigned automatically to any document you send or receive.
TX/RX NO.	Denotes <i>Transaction number</i> .
TX	Denotes <i>Sending</i> .
RX	Denotes <i>Receiving</i> .

► Contents

1: Introduction

What your machine can do	1-1
Unpacking your machine	1-2
Main components of the machine	1-3
Operation panel of the machine	1-4

2: Document handling

Document requirements	2-1
Loading documents	2-2
Using the platen glass	2-2
Fax Model Using the ADF	2-2

3: Print media handling

Recommended print media and requirements	3-1
General print media guidelines	3-4
Setting the paper thickness lever	3-5
Setting the print media size and type	3-6
Loading print media	3-7
Loading paper	3-7
Loading envelopes	3-7
Loading banner paper	3-9

4: Photo printing from a memory card

Compatible memory cards	4-1
Recommended print media	4-1
Inserting/removing a memory card	4-2
Inserting a memory card	4-2
Removing a memory card	4-3
Printing methods	4-4
Printing an index	4-5
Printing all frames	4-6
Printing a single frame	4-8
Printing a range of frames	4-10
DPOF (Digital Print Order Format) printing	4-12
Setting vivid photo printing	4-14
Setting date printing	4-14
Reading data from or writing data to a memory card	4-15
Enabling/disabling overwriting memory card data	4-15

5: Copying

Documents you can copy	5-1
Making copies	5-1
Improving copied images	5-1
Setting color or black & white copying	5-1

Adjusting the image quality (resolution)	5-2
Adjusting the exposure (density)	5-2
Reducing or enlarging a copy	5-3
Using preset copy ratios	5-3
Using custom copy ratios	5-3
Copying an image to fit the page	5-3
Advanced copy features	5-4
Copying two pages on a single page	5-4
Borderless copying	5-5
Repeating an image on a page	5-6
Creating a mirror image	5-8
Shrinking an image to fit the page	5-9

6: **Fax Model** Registering information in your machine

Guidelines for entering numbers, letters, and symbols	6-1
Registering required sender information	6-2
Entering the sender information	6-3
Setting the telephone line type	6-4
Setting daylight saving	6-5

7: **Fax Model** Speed dialing

Speed dialing methods	7-1
Registering one-touch speed dialing	7-2
Changing or deleting an entry	7-3
Registering coded speed dialing	7-4
Changing or deleting an entry	7-5
Registering group dialing	7-6
Changing or deleting an entry	7-7
Using speed dialing	7-8
Printing speed dialing lists	7-9

8: **Fax Model** Sending faxes

Documents you can fax	8-1
Sending methods	8-1
Memory sending	8-1
Manual sending	8-2
Improving faxed images	8-3
Setting color or black & white transmission ..	8-3
Adjusting the image quality (fax resolution)	8-3
Adjusting the scan exposure	8-4
Dialing methods	8-4
Redialing a busy number	8-5
Manual redialing	8-5
Automatic redialing	8-5
Customizing automatic redialing settings	8-5

Sending the same document to several recipients (sequential broadcasting)	8-7
Documents stored in memory	8-8
Printing a list of documents in memory	8-8
Printing or deleting a document in memory..	8-8
Checking a document's details	8-9
Special dialing.....	8-10
Dialing through a switchboard.....	8-10
Switching temporarily to tone dialing	8-10

9: **Fax Model** Receiving faxes

Setting the receive mode	9-1
Receiving both faxes and voice calls	
automatically: FAX/TEL AUTO SW.....	9-2
Customizing FAX/TEL AUTO SW	9-2
Receiving faxes automatically:	
FAX ONLY MODE.....	9-3
Receiving with a DRPD (Distinctive Ring Pattern Detection) service: DRPD	9-4
Setting the ring pattern.....	9-4
Receiving faxes manually: MANUAL MODE	9-5
Receiving when an answering machine is connected: ANS.MACHINE MODE	9-6
Adjusting the answering machine	9-6
Canceling receiving	9-6

10: **Fax Model** Reports and lists

Summary of reports and lists	10-1
ACTIVITY REPORT	10-2
Printing the ACTIVITY REPORT	10-2
Adjusting the ACTIVITY REPORT setting.....	10-2
Adjusting the TX REPORT setting	10-3
Adjusting the RX REPORT setting	10-4
Printing the USER'S DATA LIST	10-5

11: Maintenance

Replacing ink tanks	11-1
When to replace an ink tank	11-1
Guidelines.....	11-1
Replacing an ink tank	11-2
Maintaining the printhead.....	11-3
Flowchart of printhead maintenance.....	11-3
Printing the nozzle check pattern.....	11-4
Cleaning the printhead.....	11-4
Aligning the printhead	11-5
Cleaning your machine	11-7
Cleaning the exterior.....	11-7
Cleaning the interior.....	11-7
Cleaning the scanning area	11-7
Cleaning inside the machine	11-7
Fax Model Cleaning the ADF area.....	11-8
Cleaning the roller	11-9

12: Troubleshooting

Problems installing and removing software ..	12-1
Problems turning on the computer	12-2
Problems printing from your computer	12-2
Copying problems	12-5
Problems scanning	12-6
Fax Model Problems receiving faxes	12-9
Fax Model Problems sending faxes.....	12-11
Fax Model Telephone problems.....	12-12
Problems using a memory card.....	12-12
If nothing displays in the LCD (if there is no power).....	12-14
Fax Model If the power disconnects unexpectedly	12-15
Removing jammed paper	12-15
Removing jams in the paper output tray ..	12-15
Removing jams from the machine's interior	12-15
If there are repeated paper jams.....	12-16
Fax Model Removing jammed documents	12-16
If the nozzle check pattern does not print properly.....	12-18
Interpreting the messages.....	12-18
LCD messages.....	12-19
If you cannot solve the problem	12-23

13: Machine settings

Fax Model Printing a list to check the current settings.....	13-1
Accessing the machine settings	13-1
Settings.....	13-2
Menu: SPECIAL COPY	13-2
Menu: MAINTENANCE	13-2
Menu: USER DATA.....	13-3
Fax Model Menu: RECEIVE MODE.....	13-6
Fax Model Menu: MEMORY REFERENCE	13-6
Fax Model Menu: REPORTS/LISTS	13-6
Menu: PHOTO PRINT MODE.....	13-7

Appendix: Specifications

General specifications	A-1
Ink specifications.....	A-3
Print specifications	A-4
Photo print specifications	A-4
Copy specifications	A-4
Fax Model Fax specifications	A-5
Telephone specifications.....	A-6

Index.....	I-1
------------	-----

► Safety information

Read this safety information thoroughly before using your machine, and keep it handy in case you need to refer to it later.

▲ WARNING

- **This product emits low level magnetic flux. If you use a cardiac pacemaker and feel abnormalities, please move away from this product and consult your doctor.**

▲ CAUTION

- **Do not disassemble or modify. There are high-temperature and high-voltage components inside the machine which may result in fire or electrical shock.**
- **Follow all warnings and instructions marked on the machine.**

Location

▲ WARNING

- **Do not place the machine near alcohol, paint thinner, or other flammable substances. If flammable substances come into contact with electrical parts inside the machine, it may result in fire or electrical shock.**



▲ CAUTION

- **Do not place the machine on top of a carpet or rug which has long pile. The threads may get inside the machine and cause a fire.**
- **Place the machine on a flat, stable, vibration-free surface that is strong enough to support its weight. (For the weight of the machine, see the Appendix.)**

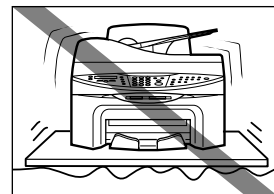

- **Do not place objects around the power plug so that you are able to readily disconnect the power plug from the wall socket at any time. Otherwise you will be unable to disconnect the power plug in case of an emergency.**
- Make sure the area is free from dust.
- Make sure the location is not affected by extreme temperature changes, and always stays between 59° and 81.5°F (15° and 27.5°C).
- Make sure the relative humidity of the area is between 20% and 80%.
- Keep the machine away from direct sunlight.
- Do not use or store the machine outdoors.
- Do not install the machine near devices that contain magnets or generate magnetic fields, such as speakers.

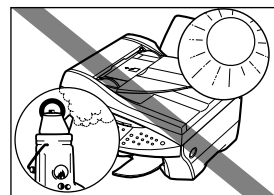

Power Supply

⚠ WARNING

- Do not damage or modify the power cord and power plug. Also do not place heavy objects on the power cord, pull on it, or extensively bend it. These actions may cause electrical damage and result in fire or electrical shock.

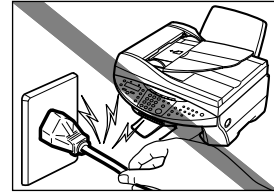

- Do not insert or unplug the power plug with wet hands, as this may result in electrical shock.

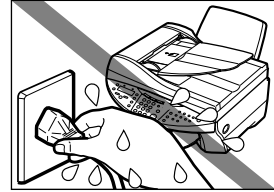

- Do not overload the wall outlet with too many electrical appliances, as this may result in fire or electrical shock.
- Plug the machine into a standard 120 V AC, 60 Hz, three-prong outlet. Operate the machine only from the type of power source indicated on the machine's label or a fire, electrical shock or malfunction may occur. If you are not sure of the type of power available, consult your local power company.
- Do not allow the power cord to be near objects that emit heat. The outer cover of the power cord may melt resulting in fire or electrical shock.
- Make sure the power cord is fully extended and has no knots in it when electricity is running through it. Knots etc. in the cord may result in fire or electrical shock.
- Fully insert the power plug securely into the electrical outlet. If the prongs of the power plug come into contact with metallic objects etc., it may result in fire or electrical shock.

⚠ CAUTION

- During electrical storms, turn off the power and disconnect the power cord from the power outlet. (Please note that any documents stored in the machine's memory will be deleted when you turn off the power.)

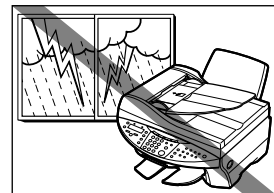

- Do not use an extension cord as this may result in fire or electrical shock.
- Turn off the power and disconnect the power cord if the machine will not be used for a long period such as during holidays.

ⓘ IMPORTANT

- If dust accumulates around the plug of the power cord when it is connected to a power outlet, unplug the machine and wipe the plug with a clean, dry cloth.
- **Fax Mode** Do not plug the machine into the same circuit as appliances such as an air conditioner, television, or copier. These devices generate electrical noise which may interfere with your machine's operation.
- Whenever you turn off the power and unplug the machine, wait at least five seconds before you plug it in again.
- Use only the power cord that came with the machine.
- Turn off the power and unplug the machine in the following conditions:
 - When the power cord or plug is damaged or frayed.
 - If liquid has spilled into the machine.
 - If the machine has been exposed to rain or water.
 - If the machine does not operate normally when you have followed the instructions in the guides included with your machine. Adjust only those controls that are covered by the instructions in the guides since improper adjustment of other controls may result in damage and will often require extensive work by a qualified technician to restore the product to normal operation.
 - If the machine has been dropped or damaged.
 - If the machine exhibits a distinct change in performance, indicating a need for servicing.

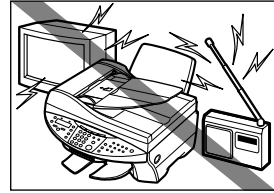

Handling

⚠ WARNING

- Do not drop paper clips, staples, or other metal objects inside the machine. Also do not spill water, liquid, or flammable substances inside the machine. If these items come into contact with high-voltage parts inside the machine, it may result in fire or electrical shock. If these items are dropped or spilled in the machine, turn off the power and unplug the power cord immediately with dry hands. Then contact the Canon Customer Care Center.
- Do not use any highly flammable sprays near the machine. If gas from a spray comes into contact with the electrical components inside the machine, it will result in fire.
- There are high-voltage components inside the machine. If you are looking inside the machine to remove paper jams etc., do not allow metallic objects such as jewelry to come into contact with the inside of the machine. Contact may result in burns or electrical shock.

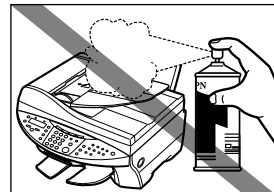
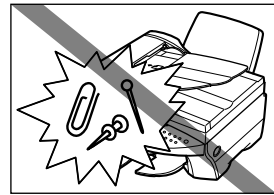

⚠ CAUTION

- Close the document cover and scanning unit gently to avoid catching your hand. Failing to do so may result in personal injury.

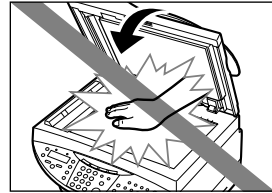

- Do not press down hard on the document cover or **Fax Model** ADF when using the platen glass to scan thick books. This may damage the platen glass and/or result in personal injury.

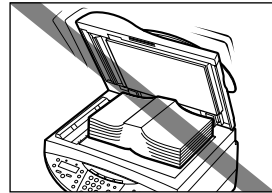

- Do not place the following objects on top of the machine. If such objects come into contact with internal electrical components, the machine may short-circuit resulting in fire or electrical shock.
 - Metallic objects such as jewelry and watches
 - Containers of water or other liquids such as glasses, vases, or pot plantsIf water etc. does spill inside the machine, turn off the power immediately, disconnect the power cord and contact the Canon Customer Care Center.
- Do not touch the high-voltage electrical parts as this may result in electrical shock.
- Do not place heavy objects on top of the machine as these may topple over and result in injury.
- Do not insert your hands into the machine while it is printing as parts inside the machine are moving and this may result in injury.
- After printing, do not touch the electrical contacts of the printhead. They will be hot and may result in burns or electrical shock.
- Do not subject the machine to strong physical shock or vibration.
- Turn off the power and unplug the machine before moving it.
- Do not lift the machine by any of its attachments. Lift it by the recessed areas on the sides of the machine.
- A distinct change in performance may indicate a need for servicing.

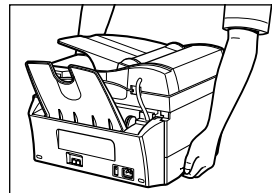

Maintenance

⚠ WARNING

- Do not service the machine yourself except as specifically described in this guide. If further servicing is required, contact the Canon Customer Care Center.
- Keep the machine clean. Dust accumulation may prevent the machine from operating properly.

► Legal limitation on usage of your product and the use of images

Using your product to scan, print or otherwise reproduce certain documents, and the use of such images as scanned, printed or otherwise reproduced by your product, may be prohibited by law and may result in criminal and/or civil liability. A non-exhaustive list of these documents is set forth below. This list is intended to be a guide only. If you are uncertain about the legality of using your product to scan, print or otherwise reproduce any particular document, and/or of the use of the images scanned, printed or otherwise reproduced, you should consult in advance with your legal advisor for guidance.

- Paper money
- Money orders
- Certificates of deposit
- Postage stamps (canceled or uncanceled)
- Identifying badges or insignias
- Selective service or draft papers
- Checks or drafts issued by governmental agencies
- Motor vehicle licenses and certificates of title
- Traveler's checks
- Food stamps
- Passports
- Immigration papers
- Internal revenue stamps (canceled or uncanceled)
- Bonds or other certificates of indebtedness
- Stock certificates
- Copyrighted works/works of art without permission of copyright owner

► Users in the U.S.A.

Pre-installation requirements for Canon facsimile equipment

A. Location

Supply a suitable table, cabinet, or desk. See the Appendix for the machine's dimensions and weight.

B. Order information

1. Only a single line, touch-tone or rotary telephone set is to be used.
2. Order an RJ11-C modular jack (USOC code), which should be installed by the telephone company. If the RJ11-C jack is not present, installation cannot occur.
3. Order a normal business line from your telephone company's business representative. The line should be a regular voice grade line or the equivalent. Use one line per machine.
DDD (DIRECT DISTANCE DIAL) LINE
-or-
IDDD (INTERNATIONAL DIRECT DISTANCE DIAL) LINE IF YOU COMMUNICATE OVERSEAS

NOTE

- Canon recommends an individual line following industry standards, e.g., the 2500 (Touch Tone) or 500 (Rotary/Pulse Dial) telephones. A dedicated extension off a PBX unit without "Call Waiting" can be used with the MultiPASS MP730. Key telephone systems are not recommended because they send non-standard signals to individual telephones for ringing and special codes, which may cause a fax error.

C. Power requirements

This equipment should be connected to a standard 120-volt AC, three-wire grounded outlet only. Do not connect this machine to an outlet or power line shared with other appliances that cause "electrical noise." Air conditioners, electric typewriters, copiers, and machines of this sort generate electrical noise which often interferes with communications equipment and the sending and receiving of documents.

Connection of the equipment

This equipment complies with Part 68 of the FCC rules and the requirements adopted by the ACTA. On the rear panel of this equipment is a label that contains, among other information, a product identifier in the format US:AAAEQ##TXXXX. If requested, this number must be provided to the telephone company.

The REN is used to determine the number of devices that may be connected to a telephone line. Excessive RENs on a telephone line may result in the devices not ringing in response to an incoming call. In most but not all areas, the sum of RENs should not exceed five (5.0). To be certain of the number of devices that may be connected to a line, as determined by the total RENs, contact the local telephone company. The REN for this product is part of the product identifier that has the format US:AAAEQ##TXXXX. The digits represented by ## are the REN without a decimal point (e.g., 03 is a REN of 0.3).

This equipment may not be used on coin service provided by the telephone company. Connection to party lines is subjected to state tariffs.

In case of equipment malfunction

Should any malfunction occur which cannot be corrected by the procedures described in this guide, disconnect the equipment from the telephone line or turn off the power and unplug the power cord. The telephone line should not be reconnected or the power cord plugged in until the problem is completely resolved. Users should contact Canon Authorized Service Facilities for servicing of equipment. Information regarding Authorized Service Facility locations can be obtained by calling the Canon Customer Care Center. (1-800-423-2366)

Rights of the telephone company

Should the equipment cause harm to the telephone network, the telephone company may temporarily disconnect service. The telephone company also retains the right to make changes in facilities and services which may affect the operation of this equipment. When such changes are necessary, the telephone company is required to give adequate prior notice to the user.

FCC Notice

MultiPASS MP730: Facsimile Transceiver, Model H12269

MultiPASS MP700: H12270

This device complies with Part 15 of the FCC Rules.

Operation is subject to the following two conditions:

- (1) This device may not cause harmful interference, and
- (2) this device must accept an interference received, including interference that may cause undesired operation.

NOTE

- This equipment has been tested and found to comply with the limits for a class B digital device, pursuant to Part 15 of the FCC Rules. These limits are designed to provide reasonable protection against harmful interference in a residential installation. This equipment generates, uses and can radiate radio frequency energy and, if not installed and used in accordance with the instructions, may cause harmful interference to radio communications. However, there is no guarantee that interference will not occur in a particular installation. If this equipment does cause harmful interference to radio or television reception, which can be determined by turning the equipment off and on, the user is encouraged to try to correct the interference by one or more of the following measures:

- Reorient or relocate the receiving antenna.
- Increase the separation between the equipment and receiver.
- Connect the equipment into an outlet on a circuit different from that to which the receiver is connected.
- Consult the dealer or an experienced radio/TV technician for help.

Use of shielded cable is required to comply with class B limits in Subpart B of Part 15 of the FCC Rules.

Do not make any changes or modifications to the equipment unless otherwise specified in this guide. If such changes or modifications should be made, you could be required to stop operation of the equipment.

Canon U.S.A. Inc.
One Canon Plaza, Lake Success, NY 11042, U.S.A.
TEL No. (516) 328-5600

The Telephone Consumer Protection Act of 1991 makes it unlawful for any person to use a computer or other electronic device to send any message via a telephone fax machine unless such message clearly contains in a margin at the top or bottom of each transmitted page or on the first page of the transmission, the date and time it is sent and an identification of the business or other entity, or other individual sending the message and the telephone number of the sending machine or such business, other entity, or individual.

To automatically enter this information into your machine, follow the instructions on p. 7-1 or p. 8-1 of this guide.

► Users in Canada

Pre-installation requirements for Canon facsimile equipment

A. Location

Supply a suitable table, cabinet, or desk. See the Appendix for the machine's dimensions and weight.

B. Order information

1. Provide only a single-line to touch-tone or rotary telephone set terminated with a standard 4-pin modular phone plug. (Touch-tone is recommended if available in your area.)
2. Order an RJ11-C modular jack (USOC code), which should be installed by the telephone company. If the RJ11-C jack is not present, installation cannot occur.
3. Order a normal business line from your telephone company's business representative. The line should be a regular voice grade line or equivalent. Use one line per machine.
DDD (DIRECT DISTANCE DIAL) LINE
-or-
IDDD (INTERNATIONAL DIRECT DISTANCE DIAL) LINE IF YOU COMMUNICATE OVERSEAS

NOTE

- Canon recommends an individual line following industry standards [e.g., the 2500 (touch tone) or 500 (rotary/pulse dial) telephones]. A dedicated extension off a PBX unit without "Camp On" signals is also permissible with your MultiPASS MP730. Key telephone systems are not recommended because they send non-standard signals to individual telephones for ringing and special codes, which may cause a fax error.

C. Power requirements

The power outlet should be a three-prong grounded receptacle (Single or Duplex). It should be independent from copiers, heaters, air conditioners or any electric equipment that is thermostatically controlled. The rated value is 120 volts and 15 amperes. The RJ11-C modular jack should be relatively close to the power outlet to facilitate installation.

NOTICE

This equipment meets the applicable Industry Canada Terminal Equipment Technical Specifications. This is confirmed by the registration number. The abbreviation, IC, before the registration number signifies that registration was performed based on a Declaration of Conformity indicating that Industry Canada technical specifications were met. It does not imply that Industry Canada approved the equipment.

Cet appareil est conforme aux Spécifications techniques des équipements terminaux de l'Industrie du Canada. Ceci est confirmé par le numéro d'enregistrement. L'abréviation IC précédant le numéro d'enregistrement signifie que l'enregistrement a été effectué sur la base de la Déclaration de conformité indiquant que le produit est conforme aux spécifications techniques du Canada. Ceci n'implique pas que le produit ait été approuvé par l'industrie du Canada.

Before installing this equipment, users should ensure that it is permissible to be connected to the facilities of the local telecommunications company. The equipment must also be installed using an acceptable method of connection. The customer should be aware that compliance with the above conditions may not prevent degradation of service in some situations. Repairs to certified equipment should be coordinated by a representative designated by the supplier. Any repairs or alterations made by the user to this equipment, or equipment malfunctions, may give the telecommunications company cause to request the user to disconnect the equipment.

Users should ensure for their own protection that the electrical ground connections of the power utility, telephone lines and internal metallic water pipe system, if present, are connected together. This precaution may be particularly important in rural areas.

CAUTION

- **Users should not attempt to make such connections themselves, but should contact the appropriate electric inspection authority, or electrician, as appropriate.**

IMPORTANT

- **This Class B digital apparatus meets all requirements of the Canadian Interference-Causing Equipment Regulations.**
- **Cet appareil numérique de la classe B respecte toutes les exigences du Règlement sur le matériel brouilleur du Canada.**

The Ringer Equivalence Number (REN) for this terminal equipment is 0.3. The REN assigned to each terminal equipment provides an indication of the maximum number of terminals allowed to be connected to a telephone interface. The termination on an interface may consist of any combination of devices subject only to the requirement that the sum of the Ringer Equivalence Numbers of all the devices does not exceed five.

Le Nombre d'équivalence Ringer (REN) de cet appareil terminal est 0.3. Le REN attribué à chaque équipement terminal fournit une indication sur le nombre maximum de terminaux pouvant être connectés sur une interface téléphonique. La terminaison sur une interface peut consister en n'importe quelle combinaison d'appareils, à la condition seulement que la somme des Nombres d'équivalence Ringer de tous les appareils ne soit pas supérieure à 5.

CANON CANADA INC.
1-800-OK-CANON
24 HOURS A DAY, SEVEN DAYS A WEEK
<http://www.canon.ca>

Introduction

► What your machine can do

Thank you for purchasing the Canon MultiPASS MP730 (indicated by the mark **Fax Model**) or the MultiPASS MP700. Your machine incorporates the following functions in one simple-to-operate device:

- Printer** Print crisp, clear color or black & white documents from your computer.
- Photo printer** Print photo-quality images from a memory card inserted directly into your machine.
- Copier** Make color or black & white copies from your machine. Also, apply advanced copy features to your copies.
- Scanner** Scan high-resolution images to your computer and process them easily using the software provided.
- Fax Model** Fax** Fax directly from your machine, or use your computer to send faxes.

You may choose to use your machine as a stand-alone device for photo printing, copying, and **Fax Model** faxing. Alternatively, connect your machine to a computer and you will have a fully integrated printer/photo printer/copier/scanner/**Fax Model** fax. The software provided with your machine will allow you to perform a variety of tasks from your computer effortlessly and efficiently.

► Unpacking your machine

When you unpack your machine, check that you have the following components:



• **Fax Model** MP730

Machine

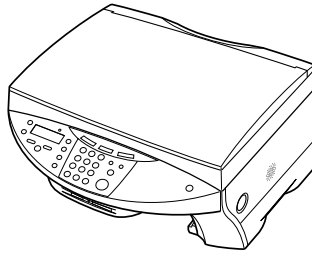

• MP700

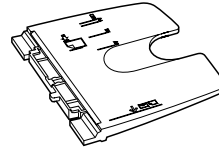

• **Multi-purpose tray**

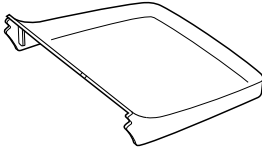

• **Tray cover**

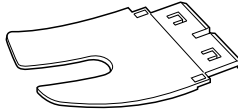

• **Paper output tray**

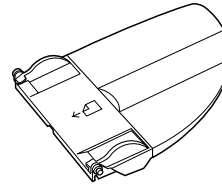

• **Fax Model** **Document tray**

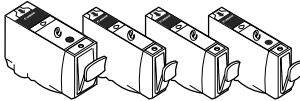

• **Ink tanks**
(Black, cyan, magenta, yellow)

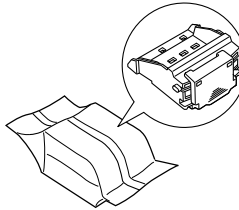

• **Printhead**

- **Power cord**
- **Documentation**
(Set-Up Sheet,
Quick Reference Guide)
- **MultiPASS MP730/700
Setup CD-ROM**
- **Fax Model** **Telephone line cord**
- **Fax Model** **Destination labels**

NOTE

- A USB cable is not included. You must purchase a USB cable (less than 16³/₈ ft./5 m) to connect your machine to a computer.

► Main components of the machine

Fax model shown here.

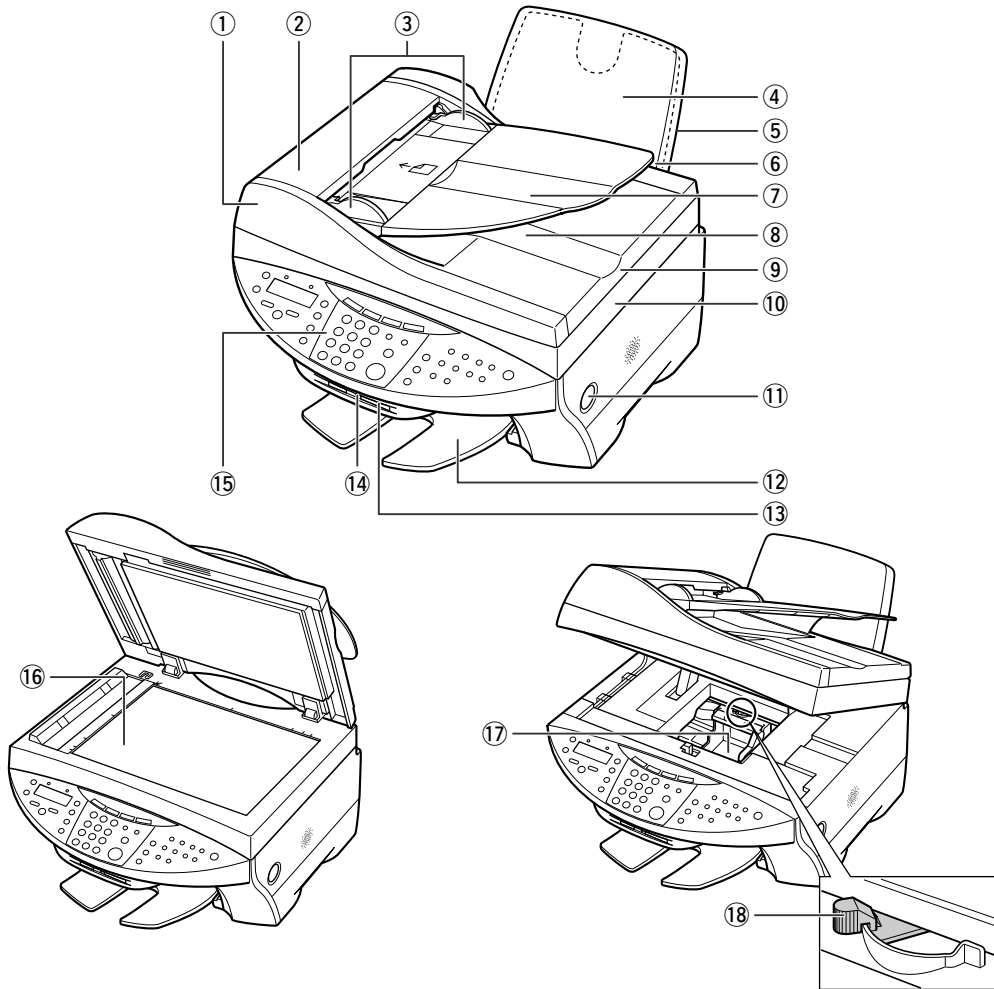

- ① **Fax Model** ADF (Automatic Document Feeder)
- ② **Fax Model** Feeder cover
- ③ **Fax Model** Document guides
- ④ Multi-purpose tray
- ⑤ Tray cover
- ⑥ Automatic sheet feeder
- ⑦ **Fax Model** Document tray
- ⑧ **Fax Model** Document output slot
- ⑨ Document cover
- ⑩ Scanning unit (Printer cover)
- ⑪ [Open] button
- ⑫ Paper output tray
- ⑬ Card slot
- ⑭ Indicator light
- ⑮ Operation panel
- ⑯ Platen glass
- ⑰ Printhead holder
- ⑱ Paper thickness lever

Operation panel of the machine

Fax model shown here.

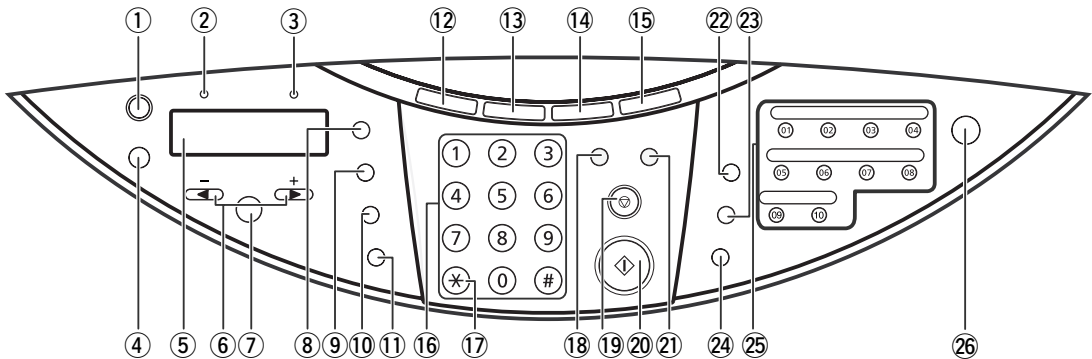

- ① **[Resume] key**
Resumes an operation after an error is corrected. **Fax Model** Also ejects a document remaining in the ADF.
- ② **Fax Model In Use/Memory light**
Blinks or lights during operation. Lights also when there are documents in the machine's memory.
- ③ **Alarm light**
Blinks when an error occurs or when the machine needs attention.
- ④ **[Menu] key**
Accesses the settings to customize operation of your machine.
- ⑤ **LCD**
Displays messages and selections, and prompts during operation.
- ⑥ **[◀]([−]) and [▶]([+]) keys**
Scroll through selections, select the number of copies, and the photograph file number.
Fax Model [◀] also clears an entry and [▶] enters a space between characters.
- ⑦ **[Set] key**
Selects or confirms settings.
- ⑧ **[Enlarge/Reduce] key**
Sets the copy enlargement or reduction ratio.
- ⑨ **[Paper Select] key**
Selects the paper size and paper type for copying and **Fax Model** received faxes.
- ⑩ **[Exposure] key**
Selects the copy exposure and **Fax Model** fax exposure.
- ⑪ **[Image Quality] key**
Selects the copy resolution and **Fax Model** fax resolution.
- ⑫ **[Copy] key**
Switches the machine to copy mode.
- ⑬ **Fax Model [Fax] key**
Switches the machine to fax mode.

- ⑭ **[Scan] key**
Scans a document to your computer according to the action selected.
- ⑮ **[Photo Print] key**
Switches the machine to photo card print mode.
- ⑯ **Numeric keys**
Enter numerical values as well as **Fax Model** fax/telephone numbers and characters.
- ⑰ ****Fax Model** [Tone] key**
Switches temporarily to tone dialing.
- ⑱ **[Color] key**
Sets the machine for color copying and **Fax Model** color sending.
- ⑲ **[Stop/Reset] key**
Cancels operations and returns the machine to standby mode.
- ⑳ **[Start] key**
Starts operations.
- ㉑ **[B&W] key**
Sets the machine for black & white copying and **Fax Model** black & white sending.
- ㉒ ****Fax Model** [Redial/Pause] key**
Redials the last number dialed with the numeric keys. Also enters pauses between or after numbers when dialing or registering numbers.
- ㉓ ****Fax Model** [Coded Dial] key**
Press this key and a two-digit code to dial a pre-registered fax/telephone number or group.
- ㉔ ****Fax Model** [Hook] key**
Engages or disengages the telephone line.
- ㉕ ****Fax Model** One-touch speed dialing keys**
Dial a pre-registered fax/telephone number or group.
- ㉖ **[ON/OFF (1 sec.)] key**
Turns the machine on and off (keep pressed for a brief interval). **Before turning on the machine, make sure the document cover is closed.**

IMPORTANT

- **To prevent the printhead from drying up, the machine automatically caps it when the power is turned off with the [ON/OFF (1 sec.)] key. If you need to disconnect the machine from the main power source (e.g. disconnect the power cord), be sure to turn off the machine first by pressing [ON/OFF (1 sec.)] before disconnecting it.**
- **If you are not using the machine for a long period of time, we recommend that you print (in black and color) or clean the printhead approximately once a month to maintain the printhead in good working condition. The printhead contains high-precision nozzles that will become blocked if the printhead is not used for a long period of time.**

NOTE

- The power cannot be turned off when the machine is operating or **Fax Model** when the In Use/Memory light is on or blinking.
- Your machine performs printhead cleaning every time you turn on the machine. This ensures optimum print quality, but also consumes a small amount of ink during the cleaning process. For this reason, it is recommended that you always leave your machine turned on, and only turn it off when instructed to do so in this guide, or when not using the machine for a long period of time (one month or more). This will avoid unnecessary ink consumption.

Document handling

► Document requirements

The documents you load on the platen glass or **Fax Model** ADF for copying, scanning, or **Fax Model** sending must meet these requirements:

	Platen glass	Fax Model ADF
Document type	<ul style="list-style-type: none"> • Special types of paper • Photographs • Book • Fax Model Documents that are not suitable for the ADF. 	Multipage documents of the same size, thickness, and weight.
Size (W × L)	Max. 8 ½ × 14 in. (216 × 356 mm) Fax Model Max. 8 ½ × 11 ¾ in. (216 × 297 mm)	Max. 8 ½ × 39 in. (216 mm × 1 m) Min. 4 ⅛ × 5 ⅞ in. (105 × 148 mm)
Quantity	<ul style="list-style-type: none"> • 1 sheet • 10 photographs for multi-scan 	<ul style="list-style-type: none"> • Max. 35 letter- or A4-size sheets (20 lb. or 75 g/m² paper) • Max. 30 legal-size sheets (20 lb. or 75 g/m² paper) • 1 sheet for sizes other than these.
Thickness	Max. ¾ in. (20 mm)	0.002 to 0.005 in. (0.06 to 0.13 mm)
Weight	—	13 to 24 lb. (50 to 90 g/m ²)

Problem documents

- Make sure any glue, ink, or correction fluid on the document is completely dry before loading.
- Remove all fasteners (staples, paper clips, etc.) before loading.
- **Fax Model** To prevent jams in the ADF, do not use any of the following:
 - Wrinkled or creased paper
 - Curled or rolled paper
 - Torn paper
 - Hole-punched paper
 - Carbon paper or carbon-backed paper
 - Coated paper
 - Onion skin or thin paper

► Loading documents

You can load your document on the platen glass or **Fax Model** ADF. Where you load it depends on the type of document and the machine you are using (→ p. 2-1).

Using the platen glass

 **NOTE**

- **Fax Model** Load legal-size documents in the ADF.

Follow this procedure to load your document on the platen glass:

- 1 Lift the document cover.**
- 2 Place your document face down on the platen glass. Align the upper left corner of your document with the alignment mark on the upper left corner of the platen glass.**

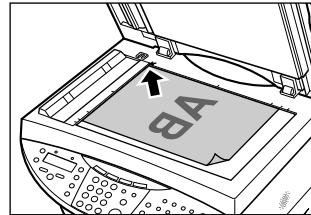

- 3 Gently lower the document cover.**

Fax Model Using the ADF

 **NOTE**

- For clearer scans, use the platen glass.

Follow this procedure to load your document in the ADF:

- 1 Check first that there is no document on the platen glass.**
- 2 Insert the top of your document, face up, into the ADF until you hear a beep ①. Then adjust the document guides to the width of the document ②.**

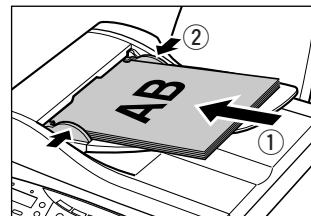

Print media handling

► Recommended print media and requirements

The following print media is recommended for use with your machine. Please be sure to follow the guidelines and meet the requirements when loading print media in the multi-purpose tray.

● Plain Paper

You can use normal photocopy paper, Canon Bubble Jet paper (LC-301), or Canon Super White paper (SW-101).

Size: • Standard paper:

Letter ($8\frac{1}{2} \times 11$ in./215.9 × 279.4 mm) A4 ($8\frac{1}{4} \times 11\frac{3}{4}$ in./210 × 297 mm)
 Legal ($8\frac{1}{2} \times 14$ in./215.9 × 355.6 mm)

• Non standard paper:

Min: $3\frac{1}{2} \times 4\frac{3}{4}$ in. (90 × 120 mm)

Max: $8\frac{1}{2} \times 23$ in. (215.9 × 584.2 mm)

Weight: 17–28 lb. (64–105 g/m²)

Quantity: Approx. 150 sheets or maximum stack height of $\frac{1}{2}$ in. (13 mm)

Paper thickness lever position: Left

Printer driver setting ([Media Type]): [Plain Paper]

Use for: All functions

- The machine supports the above paper sizes in portrait orientation.

● Envelopes

Size: U.S. Commercial No. 10 ($9\frac{1}{2} \times 4\frac{1}{8}$ in./241 × 105 mm)

European DL ($8\frac{5}{8} \times 4\frac{3}{8}$ in./220 × 110 mm)

Quantity: 10 envelopes

Paper thickness lever position: Right

Printer driver setting ([Media Type]): [Envelope]

Use for: Printing from your computer

- You cannot load envelopes of other sizes than those listed above.
- Do not use envelopes with double flaps or pressure seals as these do not feed properly.
- Do not use envelopes made with embossed or treated surfaces as print quality will deteriorate.
- Remove each envelope as soon as it is printed.
- For details on loading envelopes, see p. 3-7.

● High Resolution Paper HR-101N

This type of paper provides better color reproduction than plain paper. It is suitable for printing business documents that feature graphics, and for photographs.

Size: Letter, A4

Quantity: Approx. 80 sheets or maximum stack height of $\frac{1}{2}$ in. (13 mm)

Paper thickness lever position: Left

Printer driver setting ([Media Type]): [High Resolution Paper]

Use for: Printing from your computer/copying

- Load the paper with the whiter side facing up.
- Do not allow more than 50 sheets to stack up in the paper output tray. If the output paper is curled, it may prevent the next sheet being ejected. In this case, or if the ink takes a long time to dry, remove each sheet as soon as it is printed.

● Glossy Photo Paper GP-301/GP-301N

This media is thicker than High Resolution Paper and has a glossy printing surface to produce printouts close to photograph quality. This paper is suitable for borderless printing.

Size: Letter, A4

Quantity: 10 sheets

Paper thickness lever position: Left

Printer driver setting ([Media Type]): [Glossy Photo Paper]

Drying time: 2 minutes

Use for: Printing from your computer/copying

- Load the paper with the whiter side facing up.
- Do not use the loading support sheet provided with the package.
- Remove each sheet as soon as it is printed.
- Do not touch the printed surface until the ink is fixed.

● Matte Photo Paper MP-101

This is a matte water-resistant paper and provides superior color reproduction. It is suitable for a variety of printing purposes such as paper crafts, calendars and matte photographs.

Size: Letter, A4

Quantity: 10 sheets

Paper thickness lever position: Left

Printer driver setting ([Media Type]): [Matte Photo Paper]

Use for: All functions

- Load the paper with the glossier side facing up.
- Remove each sheet as soon as it is printed.
- Do not touch the printed surface until the ink is fixed.

● Photo Paper Plus Glossy PP-101

This is a thick paper with a glossy water-resistant coating and provides superior color reproduction. It is ideal for printing high-quality photographs.

Size: Letter, A4, 4 × 6 in. (101.6 × 152.4 mm), 5 × 7 in. (127.0 × 177.8 mm)

Quantity: 10 sheets, 20 sheets (4 × 6 in./101.6 × 152.4 mm size)

Paper thickness lever position: Left

Printer driver setting ([Media Type]): [Photo Paper Plus Glossy]

Use for: All functions

- Load the paper with the glossier side facing up.
- Remove each sheet as soon as it is printed.

● Photo Paper Pro PR-101

This is thick paper with a treated surface that enhances gloss and provides superior color reproduction. It is ideal for printing high-quality photographs. Also, by using borderless printing, you can print without any white borders.

Size: Letter, A4, 4 × 6 in. (101.6 × 152.4 mm), 5 × 7 in. (127.0 × 177.8 mm)

Quantity: 10 sheets, 20 sheets (4 × 6 in./101.6 × 152.4 mm size)

Paper thickness lever position: Left

Printer driver setting ([Media Type]): [Photo Paper Pro]

Drying time: 30 minutes

Use for: All functions

- Load the paper with the glossier side facing up, one sheet at a time to stop them from sticking together.

● Photo Paper Pro PC-101S

This card-size paper for printing photographs is made of the same material as Photo Paper Pro (PR-101). By printing the image beyond the perforations, you can then trim the borders to produce a photograph without any white borders.

Size: 4 × 6 in. (101.6 × 152.4 mm)

Quantity: 20 sheets

Paper thickness lever position: Left

Printer driver setting ([Media Type]): [Photo Paper Pro]

Drying time: 30 minutes

Use for: All functions

- Load the paper with the glossy side facing up.

● Transparencies CF-102

This film is ideal for printing presentation material for use with overhead projectors.

Size: Letter, A4

Quantity: 30 sheets

Paper thickness lever position: Left

Printer driver setting ([Media Type]): [Transparency]

Drying time: 15 minutes

Use for: Printing from your computer/copying

- Load one sheet of plain paper as the last sheet in the stack.
- Although you can print on either side of CF-102 transparencies, best results can be obtained by printing on the side toward which it curls when held by the edge.
- Do not touch the printed surface or stack the transparencies until the ink is fixed. If you are storing the transparencies for a long period of time, cover the printed sides with plain paper before storing.
- Remove each transparency as soon as it is printed.

● T-Shirt Transfers TR-201

This paper is used to produce iron-on transfers.

Size: Letter, A4

Quantity: 1 sheet

Paper thickness lever position: Right

Printer driver setting ([Media Type]): [T-Shirt Transfer]

Use for: Printing from your computer/copying

- Load the paper with the side that does not have green lines facing up.
- Use mirror printing to print or copy the image onto the T-shirt transfer.
- If the T-shirt transfer is curled, flatten it by curling it in the opposite direction.
- Remove each T-shirt transfer as soon as it is printed.
- The T-shirt transfer should be used as soon as it is printed. Refer to the supplied instructions for details on how to use this print media.

General print media guidelines

• Print media you cannot use:

- Folded print media
 - Curled print media
 - Creased print media
 - Moist print media
 - Very thin print media (less than 17 lb. or 64 g/m²)
 - Very thick print media (more than 28 lb. or 105 g/m²)
 - Print media with holes (e.g. punched holed)
 - Envelopes with double flaps
 - Envelopes with pressure seals
 - Envelopes made with embossed or treated surfaces
 - Hold the print media as closely as possible to its edges and try not to touch the printing surface. Printing quality will deteriorate if the printing surface is damaged or becomes dirty.
 - Do not touch the printing surface until the ink has dried.
 - Some print media may curl and the printing surface may smudge if you have used a large amount of ink for printing. If this occurs, move the paper thickness lever to the right (→ p. 3-5). Paper that tends to curl is not recommended for printing photographs or graphics. Use for printing mainly text.
 - Do not use print media that is in bad condition (→ above). If the print media is curled, uncurl it before printing.
 - Place the print media you have not used back into its packet and store out of direct sunlight in a place where temperature and humidity is low.
- ### • Photo Paper Pro guidelines:
- Do not touch the printed surface until the ink is fixed (approx. 30 minutes). Colors in dark images may appear indistinct at first, but will become clearer after about 30 minutes.
 - Images may smudge if you place them in an album before the ink is completely dry. It is recommended that you allow the ink to dry for 24 hours.
 - Do not attempt to dry the ink with a hairdryer or by exposing printed sheets to direct sunlight.

- Do not store or display printouts in hot, damp, or humid conditions. Never expose them to heat or direct sunlight.
- Store printouts in photo albums, photo frames, or presentation binders to protect them from direct exposure to air or sunlight.
- Do not mount printouts in an adhesive-type album as you may not be able to remove them.
- Be aware that some types of clear plastic folders and albums may cause the edges of the paper to turn yellow.

► Setting the paper thickness lever

The paper thickness lever adjusts the gap between the printhead and the print media to suit the print media's thickness. Before printing, be sure to set the paper thickness lever.

Follow this procedure to set the paper thickness lever:

1 Press [Open] ① and lift up the scanning unit ②.

- The printhead holder automatically moves to the center of the machine.

▲ CAUTION

- Do not try to manually move or stop the printhead holder.
- Do not touch any metal parts.

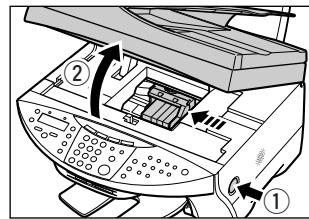

2 Move the paper thickness lever to the appropriate setting.

- For details on which position to set for the print media you are using, see pp. 3-1 to 3-4.

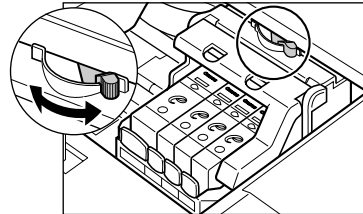

3 Close the scanning unit until it locks into place.

► Setting the print media size and type

For copying and **Fax Model** receiving faxes, you need to set the size and type of print media loaded in the multi-purpose tray.

NOTE

- For documents printed from your computer, specify the print media size and type on your computer (→ *Software Guide*).
- For photo printing, specify the print media size as described in Chapter 4.

Follow this procedure to set the print media size and type:

1 Press [Copy] or **Fax Model [Fax].**

2 Press [Paper Select].

Ex:

SIZE :	<	LTR	>
TYPE :		PLAIN	

3 Use [◀**] or [**▶**] to select the print media size.**

- Select:
 - <LTR> for letter-size print media.
 - <LGL> for legal-size print media.
 - <4" × 6"> for card-size print media.
 - <5" × 7"> for card-size print media.
 - <A4> for A4-size print media.
- **Fax Model** For received faxes, select <LTR>, <LGL>, or <A4>.

4 Press [Set].

Ex:

SIZE :		LTR	
TYPE :	<	PLAIN	>

5 Use [◀**] or [**▶**] to select the print media type.**

- Select:
 - <PLAIN> for plain paper.
 - <GLOSSY> for glossy photo paper.
 - <H.RES.> for high resolution paper.
 - <TRANS.> for transparencies.
 - <PHOTO> for photo paper pro, photo paper plus glossy, or matte photo paper.

6 Press [Set].

► Loading print media

Loading paper

Follow this procedure to load paper in the multi-purpose tray:

- 1 Remove the tray cover.**
- 2 Place a stack of paper (print side up) in the multi-purpose tray ①. Pinch the paper guide ② and adjust to the width of the stack ③.**

ⓘ IMPORTANT

- Make sure the stack does not exceed the paper limit mark ④ or tab ⑤. Otherwise a paper jam may occur.

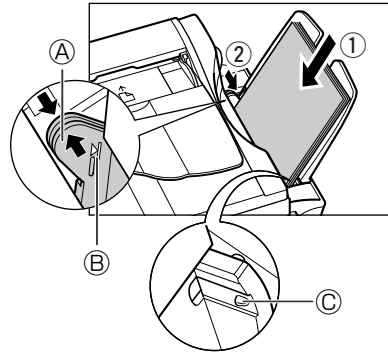

- 3 Replace the tray cover over the multi-purpose tray.**

Loading envelopes

Follow this procedure to load envelopes in the multi-purpose tray:

- 1 Make sure the paper thickness lever is set to the right.**
 - For details, see p. 3-5.
- 2 Remove the tray cover.**
- 3 Prepare the envelopes for loading:**
Press down firmly on the edges of the envelopes to make the folds crisp. Also, press firmly on the area that corresponds to the edges of the back flap.

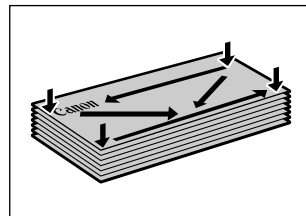

Remove any curling by holding the edges diagonally and bending them gently.

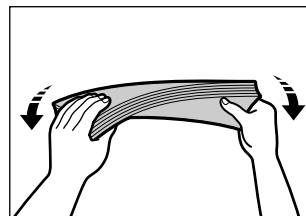

If the edges of the envelope are inflated or are curling up, place the envelope on a desk and with a pen press down on it moving from the center toward the edges of the envelope.

- Ensure that no curl or puff exceeds $\frac{1}{8}$ in. (3 mm).

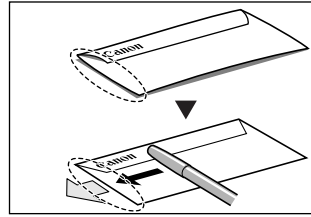

Cross-sections of the envelope edge



Incorrect

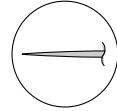

Correct

- 4 Place the stack of envelopes (print side up) in the multi-purpose tray ①. Pinch the paper guide ② and adjust to the width of the stack ③.**

- Feed the left side of the envelope (return address portion) into the multi-purpose tray first.

ⓘ IMPORTANT

- **Make sure the stack does not exceed the paper limit mark ④ or tab. Otherwise a paper jam may occur.**

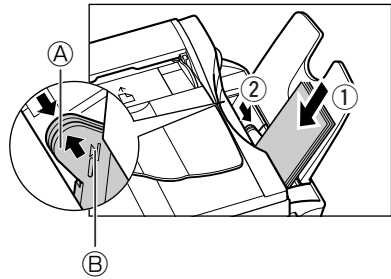

- 5 Replace the tray cover over the multi-purpose tray.**

Loading banner paper

 **NOTE**

- Always leave an extra sheet at the end of the banner—just in case the type runs over.
- Printing on banner paper may require considerable amounts of ink, so use new ink tanks if necessary.
- For best print results on banner paper, use light design patterns.

Follow this procedure to load banner paper in the multi-purpose tray:

1 Make sure the paper thickness lever is set to the right.

- For details, see p. 3-5.

2 Remove the tray cover and multi-purpose tray, and place the machine near the edge of a table so that the paper can flow over the edge as it exits the machine.

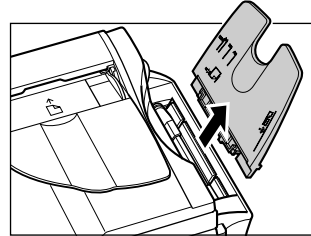

3 Cut the banner paper to the required length and place it behind the machine on a flat surface. Then insert the first sheet and press gently down on the sheet ①. Pinch and adjust the paper guide to the width of the paper ②.

- Press down gently on the sheet until paper feeding starts.
- Make sure the sheets behind the machine are aligned with the first sheet.

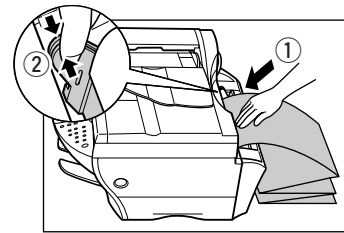

4 Set your computer to print on banner paper.

- Allow the paper to flow over the edge of the table as it exits the machine.

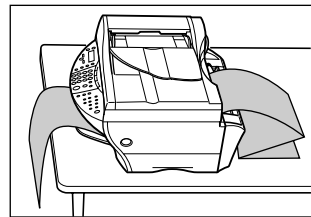

Photo printing from a memory card

This feature allows you to insert a memory card directly into your machine and print photographs from it. You can also read data from and write data to a memory card from your computer.

► Compatible memory cards

The following cards are compatible with the machine:

- Compact flash type I
- Compact flash type II (Except Microdrive memory cards)
- Memory stick
- Smart media
- Multimedia card
- SD memory card

⚠ CAUTION

- **You cannot use Microdrive memory cards.**
- **You cannot use Smart media that has less than 2 MB of memory.**

📌 NOTE

- The above cards are acceptable for this machine. However, due to varying specifications, Canon cannot guarantee that all card brands will be fully compatible.
- The file format is compatible with the JPEG (DCF/Exif 2.2 or lower/JFIF) format.
- Some digital cameras are not compatible with 64 MB and 128 MB memory cards. Photographs on memory cards that are not compatible with the camera may be unreadable or the image data may be damaged.
- Format the memory card with a digital camera. The memory card may not be able to be used with the machine if formatted by a computer.
- For information on memory cards compatible with your digital camera, contact your digital camera manufacturer.
- If you have copied photographs from a memory card to your computer and then edited them, be sure to print them from your computer. Copying edited photographs back onto a memory card and then printing them from your machine will not produce good results.

► Recommended print media

Although you can use plain paper, Photo Paper Pro paper is recommended for high-quality images (→ p. 3-3).

► Inserting/removing a memory card

Inserting a memory card

Follow this procedure to insert a memory card into the machine:

🔔 IMPORTANT

- The machine only recognizes one memory card at a time. Do not insert memory cards into both slots or the same slot at the same time as the machine will not recognize them.
- When switching between memory cards of the same type or inserting a memory card into a different card slot, press [ON/OFF (1 sec.)] to turn off the power before removing the card. Once removed, press [ON/OFF (1 sec.)] again to turn on the power before inserting the other memory card.
- In Windows 2000, if you turn off the machine, the [Unsafe Removal of Device] screen will be displayed. In this case, click [OK]. This will not affect your machine or computer's operation.
- If you insert memory cards into both slots, the compact flash card will be recognized.

1 Make sure the machine is on.

- If not, press [ON/OFF (1 sec.)].

2 Insert a memory card into the appropriate slot.

- The indicator light (A) will blink when the memory card is being accessed.
- Insert the Multimedia card into the same slot as the SD memory card.

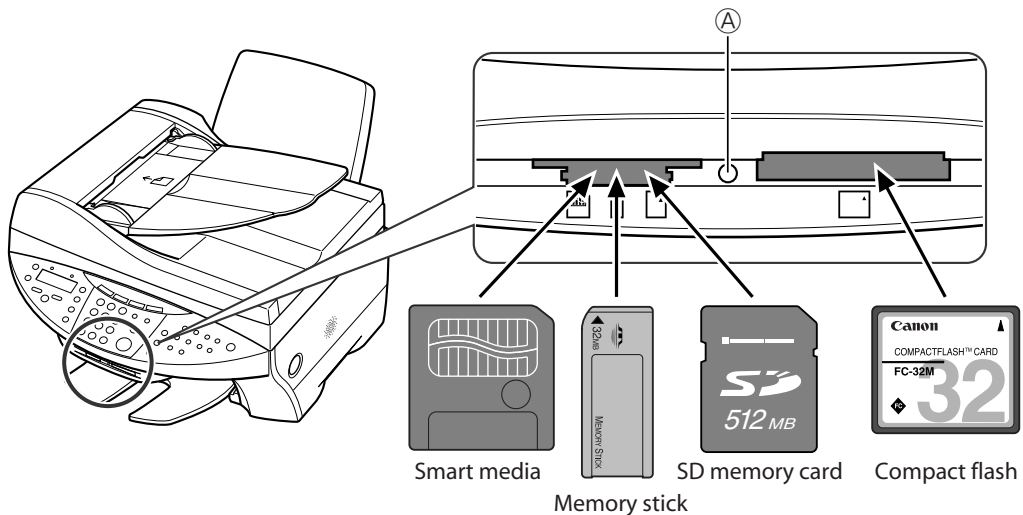

📝 NOTE

- If the memory card cannot be read, check that:
 - the memory card is inserted all the way into the card slot.
 - the memory card was not removed while being read.
 - you are using a compatible memory card.
 - your memory card contains photographs.

Removing a memory card

Follow this procedure to remove a memory card from the machine:

⚠ CAUTION

- Do not remove the memory card or turn off the machine when the indicator light is blinking as this may damage the data in the memory card.

📢 IMPORTANT

- If an error occurs during printing (e.g. paper runs out), do not remove the memory card as this may damage the data in the memory card.

- 1** Check that the indicator light is not blinking ①, then press [ON/OFF (1 sec.)] to turn the machine off ②.

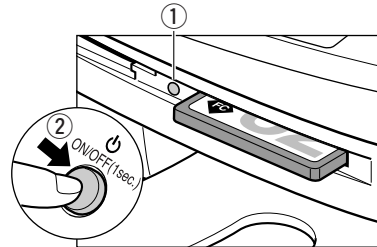

- 2** Remove the memory card.

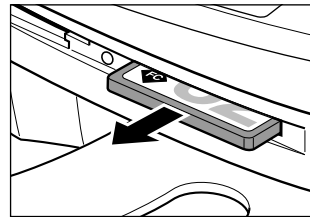

► Printing methods

There are different methods for printing photographs from a memory card. Follow this general procedure to print photographs:

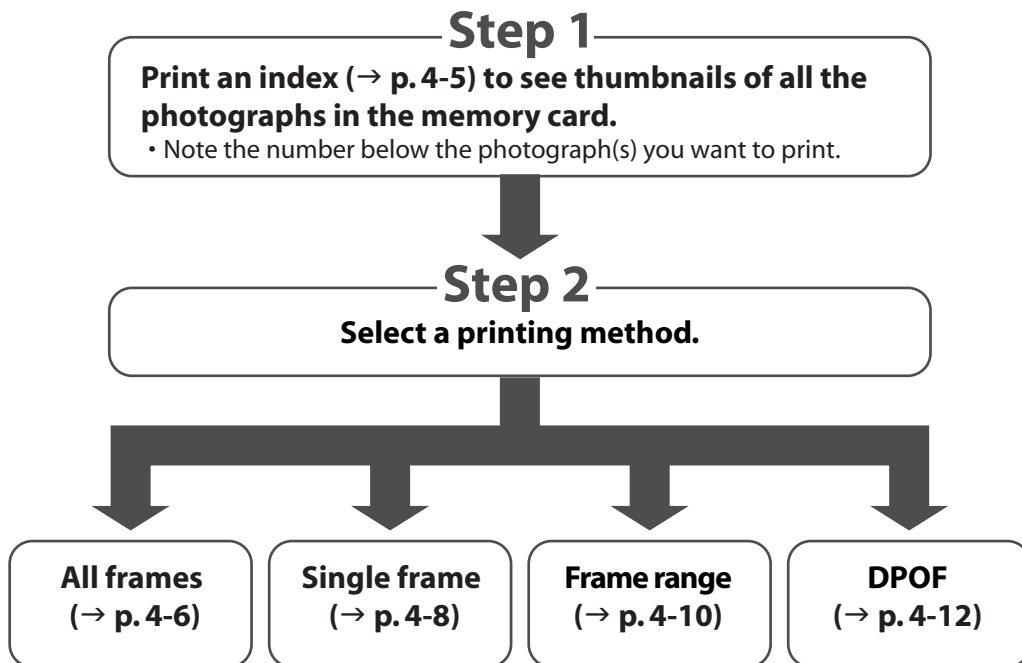

NOTE

- You may not be able to print photographs if their file sizes are too large.
- You can set vivid photo printing to make your photographs appear more vibrant. For details, see p. 4-14.
- For each printing method except DPOF, you can set date printing from the machine. For details, see p. 4-14.

Printing an index

This printing method prints thumbnails of the photographs in a memory card. An index is useful to see small versions of all photographs in a memory card without having to print each photograph individually.

When you print an index, a number (A) is assigned to each thumbnail. You will need these numbers to select the photographs you want to print in a larger format.

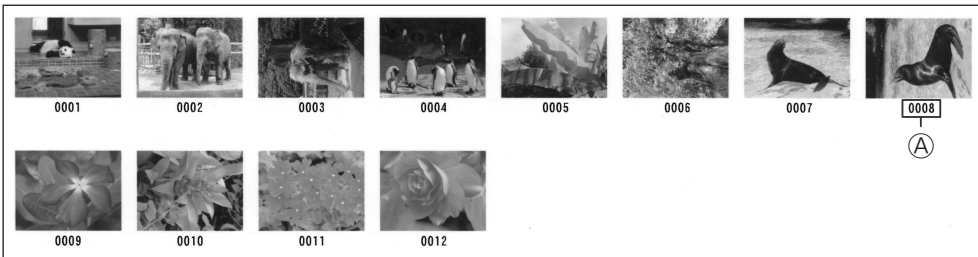

If “?” appears in the index, see p. 12-13.

Follow this procedure to print an index:

- 1 Load the correct print media in the multi-purpose tray.**
 - For details on print media and how to load it, see pp. 3-1, 3-7.
- 2 Insert the memory card as described on p. 4-2.**
- 3 Press [Photo Print].**
- 4 Press [Menu].**
- 5 Press [Set].**

Ex:

PHOTO PRINT MODE INDEX

- 6 Use [◀] or [▶] to select <INDEX>.**
- 7 Press [Set].**

Ex:

SELECT PAPER SIZE LTR

- 8 Use [◀] or [▶] to select the print media size.**
 - Select:
 - <LTR> for letter-size print media.
 - <4" × 6"> for card-size print media.
 - <5" × 7"> for card-size print media.
 - <A4> for A4-size print media.

- 9 Press [Set].**

Ex:

SELECT PAPER TYPE PHOTO PAPER PRO

10 Use [◀] or [▶] to select the print media type.

- Select from the following:
 - <PHOTO PAPER PRO>
 - <PLAIN PAPER>
- If you selected <4" × 6"> or <5" × 7"> in step 8, you can only select <PHOTO PAPER PRO>.

11 Press [Set].

Ex:

[INDEX]
PHOTO LTR

12 Press [Start].

- To cancel printing, press [Stop/Reset].

NOTE

- You can only print one index at a time.
- The number assigned to each thumbnail on the index is different from the ID numbers assigned by the digital camera.

Printing all frames

This printing method prints individually all photographs stored in a memory card.



Follow this procedure to print individually all photographs in a memory card:

1 Load the correct print media in the multi-purpose tray.

- For details on print media and how to load it, see pp. 3-1, 3-7.

2 Insert the memory card as described on p. 4-2.

3 Press [Photo Print].

4 Press [Menu].

5 Press [Set].

Ex:

PHOTO PRINT MODE
INDEX

6 Use [◀] or [▶] to select <ALL FRAMES>.

7 Press [Set].

Ex:

SELECT PAPER SIZE
LTR

8 Use [◀] or [▶] to select the print media size.

- Select:
 - <LTR> for letter-size print media.
 - <4" × 6"> for card-size print media.
 - <5" × 7"> for card-size print media.
 - <A4> for A4-size print media.

9 Press [Set].

Ex:

SELECT PAPER TYPE PHOTO PAPER PRO

10 Use [◀] or [▶] to select the print media type.

- Select from the following:
 - <PHOTO PAPER PRO>
 - <PLAIN PAPER>
- If you selected <4" × 6"> or <5" × 7"> in step 8, you can only select <PHOTO PAPER PRO>.

● If you selected <PLAIN PAPER> in step 10:**11 Go to step 13.****● If you selected <PHOTO PAPER PRO> in step 10:****11 Press [Set].**

Ex:

BORDERLESS PRINT OFF

12 Use [◀] or [▶] to select borderless printing.

- Select:
 - <OFF> to print the photographs with borders.
 - <ON> to print the photographs without borders.

13 Press [Set].

Ex:

【 ALL FRAMES 】 PHOTO LTR <input type="checkbox"/>
--

14 Press [Start].** NOTE**

- Printing is enlarged or reduced automatically according the print media size. Depending on the print media type and whether borderless printing is selected, the photographs may be cropped.
- A margin may still appear even if you select borderless printing on letter-size print media.
- You can select the width cropped from the borders of the original image (→ <EXTENSION AMOUNT>, p. 13-5).

Printing a single frame

This printing method prints a specified single photograph from a memory card. In order to select the photograph you want to print, you will need to print the index and note the number assigned to the photograph. To print an index, see p. 4-5.



Without a border



With a border

Follow this procedure to print a single photograph from a memory card:

1 Load the correct print media in the multi-purpose tray.

- For details on print media and how to load it, see pp. 3-1, 3-7.

2 Insert the memory card as described on p. 4-2.

3 Press [Photo Print].

4 Press [Menu].

5 Press [Set].

Ex:

PHOTO PRINT MODE INDEX

6 Use [◀] or [▶] to select <SINGLE FRAME>.

7 Press [Set].

FILE NO: 0001

8 Use the numeric keys to enter the frame number.

- You can also use [◀] or [▶] to select the frame number.
- To find the frame number, you will need to print the index beforehand (→ p. 4-5).

9 Press [Set].

NUMBER OF PRINTS 1COPIES

10 Use the numeric keys to enter the number of copies of the photograph you want.

- You can also use [◀] or [▶] to select the quantity.

11 Press [Set].

Ex:

SELECT PAPER SIZE LTR

12 Use [◀] or [▶] to select the print media size.

- Select:
 - <LTR> for letter-size print media.
 - <4" × 6"> for card-size print media.
 - <5" × 7"> for card-size print media.
 - <A4> for A4-size print media.

13 Press [Set].

Ex:

SELECT PAPER TYPE PHOTO PAPER PRO

14 Use [◀] or [▶] to select the print media type.

- Select from the following:
 - <PHOTO PAPER PRO>
 - <PLAIN PAPER>
- If you selected <4" × 6"> or <5" × 7"> in step 12, you can only select <PHOTO PAPER PRO>.

● If you selected <PLAIN PAPER> in step 14:**15 Go to step 17.****● If you selected <PHOTO PAPER PRO> in step 14:****15 Press [Set].**

Ex:

BORDERLESS PRINT OFF

16 Use [◀] or [▶] to select borderless printing.

- Select:
 - <OFF> to print the photograph with a border.
 - <ON> to print the photograph without a border.

17 Press [Set].

- Use [◀] or [▶] to view your settings in the LCD.

Ex:

【SINGLE FRAME】 PHOTO LTR 11 ▶

 or

【SINGLE FRAME】 ◀ NO.0002 01

18 Press [Start].** NOTE**

- Printing is enlarged or reduced automatically according the print media size. Depending on the print media type and whether borderless printing is selected, the photograph may be cropped.
- A margin may still appear even if you select borderless printing on letter-size print media.
- You can select the width cropped from the borders of the original image (→ <EXTENSION AMOUNT>, p. 13-5).

Printing a range of frames

This printing method prints a range of photographs in sequence from a memory card. In order to select the photographs you want to print, you will need to print the index and note the numbers assigned to them. To print an index, see p. 4-5.

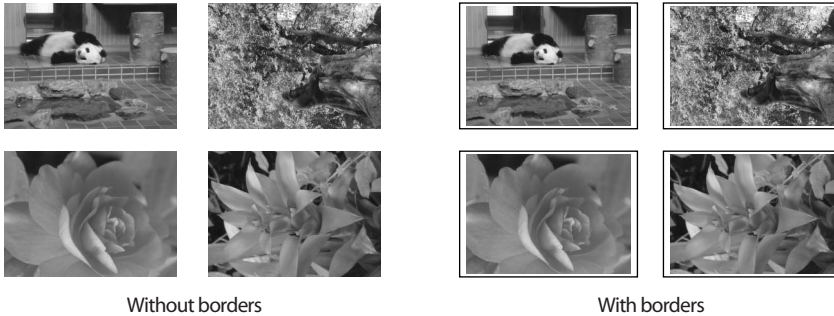

Follow this procedure to print selected photographs from a memory card:

1 Load the correct print media in the multi-purpose tray.

- For details on print media and how to load it, see pp. 3-1, 3-7.

2 Insert the memory card as described on p. 4-2.

3 Press [Photo Print].

4 Press [Menu].

5 Press [Set].

Ex: PHOTO PRINT MODE
INDEX

6 Use [◀] or [▶] to select <FRAME RANGE>.

7 Press [Set].

FIRST FILE: 0001

8 Use the numeric keys to enter the first frame number you want print.

- You can also use [◀] or [▶] to select the frame number.
- To find the frame number, you will need to print the index beforehand (→ p. 4-5).

9 Press [Set].

Ex: LAST FILE: 0006

10 Use the numeric keys to enter the last frame number you want print.

- You can also use [◀] or [▶] to select the frame number.
- To find the frame number, you will need to print the index beforehand (→ p. 4-5).

11 Press [Set].

Ex: SELECT PAPER SIZE
LTR

12 Use [◀] or [▶] to select the print media size.

- Select:
 - <LTR> for letter-size print media.
 - <4" × 6"> for card-size print media.
 - <5" × 7"> for card-size print media.
 - <A4> for A4-size print media.

13 Press [Set].

Ex:

SELECT PAPER TYPE PHOTO PAPER PRO

14 Use [◀] or [▶] to select the print media type.

- Select from the following:
 - <PHOTO PAPER PRO>
 - <PLAIN PAPER>
- If you selected <4" × 6"> or <5" × 7"> in step 12, you can only select <PHOTO PAPER PRO>.

● If you selected <PLAIN PAPER> in step 14:**15 Go to step 17.****● If you selected <PHOTO PAPER PRO> in step 14:****15 Press [Set].**

Ex:

BORDERLESS PRINT OFF

16 Use [◀] or [▶] to select borderless printing.

- Select:
 - <OFF> to print the photographs with borders.
 - <ON> to print the photographs without borders.

17 Press [Set].

- Use [◀] or [▶] to view your settings in the LCD.

Ex:

【 FRAME RANGE 】 PHOTO LTR ▣ ▶

 or

【 FRAME RANGE 】 ◀ NO. 0001-0006

18 Press [Start].**📎 NOTE**

- Printing is enlarged or reduced automatically according the print media size. Depending on the print media type and whether borderless printing is selected, the photograph may be cropped.
- A margin may still appear even if you select borderless printing on letter-size print media.
- You can select the width cropped from the borders of the original image (→ <EXTENSION AMOUNT>, p. 13-5).

DPOF (Digital Print Order Format) printing

This printing method prints photographs according to the Digital Print Order Format (DPOF) settings specified on your digital camera.

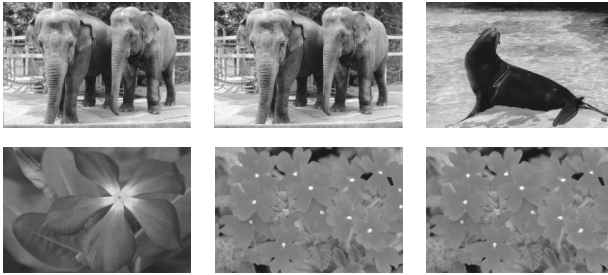

The machine supports the following DPOF functions:

- Specified frames printed
- Print style (individual photographs, index)
- Date printing on individual photographs. Date or frame number printing on index
- Number of copies to be printed

All other DPOF functions (shooting information, trimming, etc.) are not supported.

Follow this procedure for DPOF printing:

1 Load the correct print media in the multi-purpose tray.

- For details on print media and how to load it, see pp. 3-1, 3-7.

2 Insert the memory card as described on p. 4-2.

3 Press [Photo Print].

When you insert a memory card registered with DPOF settings, the LCD will automatically display DPOF.

Ex:

[DPOF] PHOTO LTR

- You can press [Start] at this point to print immediately the photographs according to the DPOF settings. However, if you want to set the print media size and type as well as borderless printing, follow the instructions below.

4 Press [Menu].

5 Press [Set] twice.

Ex:

SELECT PAPER SIZE LTR

6 Use [◀] or [▶] to select the print media size.

- Select:
 - <LTR> for letter-size print media.
 - <4" × 6"> for card-size print media.
 - <5" × 7"> for card-size print media.
 - <A4> for A4-size print media.

7 Press [Set].

Ex:

SELECT PAPER TYPE PHOTO PAPER PRO

8 Use [◀] or [▶] to select the print media type.

- Select from the following:
 - <PHOTO PAPER PRO>
 - <PLAIN PAPER>
- If you selected <4" × 6"> or <5" × 7"> in step 6, you can only select <PHOTO PAPER PRO>.

● If you selected <PLAIN PAPER> in step 8:**9 Go to step 11.****● If you selected <PHOTO PAPER PRO> in step 8:****9 Press [Set].**

Ex:

BORDERLESS PRINT OFF

10 Use [◀] or [▶] to select borderless printing.

- Select:
 - <OFF> to print the photographs with borders.
 - <ON> to print the photographs without borders.

11 Press [Set].

Ex:

【 DPOF 】 PLAIN LTR

12 Press [Start].** NOTE**

- Printing is enlarged or reduced automatically according the print media size. Depending on the print media type and whether borderless printing is selected, the photographs may be cropped.
- A margin may still appear even if you select borderless printing on letter-size print media.
- You can select the width cropped from the borders of the original image (→ <EXTENSION AMOUNT>, p. 13-5).

► Setting vivid photo printing

Enabling this setting will make photographs appear more vibrant, especially blues and greens. It is also effective for photographs that were not taken with the correct exposure. Enable or disable this setting before printing photographs from a memory card.

NOTE

- Printing will take longer when this setting is enabled.
- This setting is only effective when using photo paper pro. It cannot be used with plain paper.

Follow this procedure to enable/disable this setting:

- 1 Press [Photo Print].**
- 2 Press [Menu].**
- 3 Use [◀] or [▶] to select <VIVID PHOTO PRINT>.**
- 4 Press [Set].**

Ex:

VIVID PHOTO PRINT
OFF

- 5 Use [◀] or [▶] to select <ON> to enable vivid photo printing or <OFF> to disable it.**
- 6 Press [Set].**
 - When vivid photo printing is enabled, the LCD will display <VIVID>.

► Setting date printing

Enabling this setting will print the date, recorded by the digital camera, below each thumbnail on an index (A) or on the bottom right of the photograph (B).

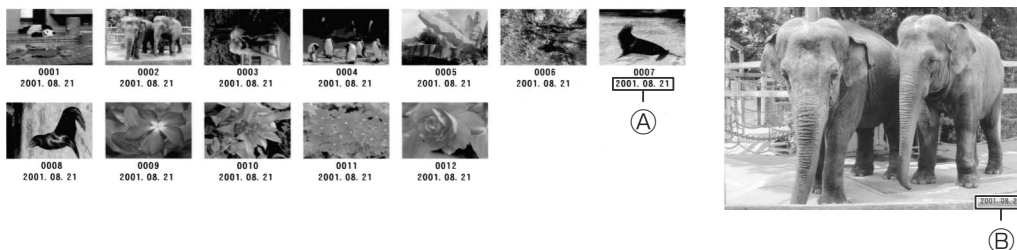

Enable or disable this setting before printing photographs from a memory card.

NOTE

- Printing will take longer when this setting is enabled.
- **Fax Model** The date format can be changed with the <DATE SETUP> setting (→ p. 13-3).
- You cannot set date printing with DPOF printing.

Follow this procedure to enable/disable this setting:

- 1 Press [Photo Print].**
- 2 Press [Menu].**
- 3 Use [◀] or [▶] to select <PRINT PHOTO DATE>.**

4 Press [Set].

Ex:

PRINT PHOTO DATE OFF

5 Use [◀] or [▶] to select <ON> to enable date printing or <OFF> to disable it.

6 Press [Set].

- When date printing is enabled, the LCD will display <0>.

▶ Reading data from or writing data to a memory card

When your machine is connected to a computer, the memory card drive (Removable Disk) will appear on your computer's [My Computer].

By inserting a memory card in the machine, you can view photographs on the memory card by opening the [Removable Disk] on your computer. You can then copy the photographs to your computer's hard disk (similar to copying other files on the hard disk), or by changing the setting, can copy hard disk files onto the memory card.

📌 IMPORTANT

- **Do not put your computer in standby or sleep mode when a memory card is inserted in a card slot. Also, do not remove or switch memory cards when your computer is in standby or sleep mode.**
- **Insert only one memory card at a time into the machine.**
- **When switching between memory cards of the same type or inserting a memory card into a different card slot, press [ON/OFF (1 sec.)] to turn off the power before removing the card. Once removed, press [ON/OFF (1 sec.)] again to turn on the power before inserting the other memory card.**
- In Windows 2000, if you turn off the machine, the [Unsafe Removal of Device] screen will be displayed. In this case, click [OK]. This will not affect your machine or computer's operation.
- If you insert memory cards into both slots, the compact flash card will be recognized.

Enabling/disabling overwriting memory card data

You can enable or disable overwriting memory card data. This setting is initially set to disable overwriting.

Follow this procedure to change the setting:

1 Make sure there is no memory card inserted in the machine.

2 Press [Menu].

3 Use [◀] or [▶] to select <USER DATA>.

4 Press [Set].

USER DATA 1. TEL REGISTRATION

5 Use [◀] or [▶] to select <SYSTEM SETTINGS>.

6 Press [Set].

7 Use [◀] or [▶] to select <CARD PROTECT>.

8 Press [Set].



9 Use [◀] or [▶] to select <ON> to disable overwriting or <OFF> to enable overwriting.

10 Press [Set].

11 Press [Stop/Reset] to return to standby mode.

12 Press [Copy], [Fax], or [Scan] to select a mode other than photo print mode.

- To avoid damage to data being accessed on a memory card, you cannot overwrite data in photo print mode.

13 Insert a memory card into the appropriate slot.

🚫 IMPORTANT

- If you change the above setting while a memory card is inserted in a card slot, turn the machine off then on again. The new setting will not be activated until you do so.

Copying

► Documents you can copy

For information on the types of documents you can copy, their requirements, and details on loading them, see Chapter 2.

► Making copies

Follow this procedure to make color or black & white copies:

- 1 Load the document on the platen glass or Fax Model ADF.**
 - For details on how to load documents, see p. 2-2.
- 2 Press [Copy].**
- 3 Use the numeric keys to enter the number of copies.**
- 4 Adjust any necessary settings for your document.**
 - Press [Color] for color copying, or [B&W] for black & white copying (→ below).
 - Press [Paper Select] to select the print media size and type (→ p. 3-6).
 - Press [Image Quality] to select the scanning resolution (→ p. 5-2).
 - Press [Exposure] to select the scanning exposure (→ p. 5-2).
 - Press [Enlarge/Reduce] to select the copy ratio (→ p. 5-3).
- 5 Press [Start].**
 - To cancel copying, press [Stop/Reset].

► Improving copied images

Setting color or black & white copying

Refer to *Making copies* (→ above) and in step 4, set color or black & white copying as follows:

For color copying: Press [Color] to turn on its light.

For black & white copying: Press [B&W] to turn on its light.

Adjusting the image quality (resolution)

Refer to *Making copies* on p. 5-1 and in step 4, adjust the image quality as follows:

1 Press [Image Quality].

2 Use [◀] or [▶] to select the image quality.

- In black & white mode, select:
 - <B&W TEXT> for text-only documents.
 - <B&W PHOTO> for photographs.
 - <B&W DRAFT> for high-speed copying at a lower resolution.*
- In color mode, select:
 - <COLOR NORMAL> for color text-only documents.**
 - <COLOR FINE> for color photographs.
 - <COLOR FAST> for high-speed color copying at a lower resolution.*

3 Press [Set].

NOTE

- When using <COLOR FAST>, if the color output is different from that expected, select <COLOR NORMAL> or <COLOR FINE> and try copying again.

Adjusting the exposure (density)

Exposure (density) is the degree of difference between light and dark. A high exposure setting will make blacks darker and whites brighter, whereas a low exposure setting will make the differences between black and white less marked.

Refer to *Making copies* on p. 5-1 and in step 4, adjust the exposure as follows:

1 Press [Exposure].

2 Use [◀] or [▶] to select the exposure.

3 Press [Set].

* This setting is only available when <PLAIN> is selected as the print media type (→ p. 3-6).

** This setting is not available when <GLOSSY> or <PHOTO> is selected as the print media type (→ p. 3-6).

► Reducing or enlarging a copy

You can reduce or enlarge copies in three different ways: using preset copy ratios, using custom copy ratios, or automatically reducing or enlarging an image to fit on the print media size selected.

NOTE

- For legal-size documents, the lowermost section of the document may not be copied.

Using preset copy ratios

Refer to *Making copies* on p. 5-1 and in step 4, adjust the copy ratio as follows:

1 Press [Enlarge/Reduce].



PRESET RATIO
- 100% +

2 Use [◀] or [▶] to select the copy ratio.

- Select from the following:
 - <25% MIN.>
 - <78% LGL → LTR>
 - <95% A4 → LTR>
 - <100%>
 - <212% 4" × 6" → LTR>
 - <400% MAX.>

3 Press [Set].

Using custom copy ratios

Refer to *Making copies* on p. 5-1 and in step 4, adjust the copy ratio as follows:

1 Press [Enlarge/Reduce] twice.

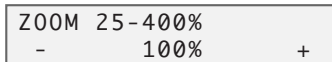

ZOOM 25-400%
- 100% +

2 Use the numeric keys to enter a copy ratio between 25% and 400%.

3 Press [Set].

Copying an image to fit the page

If the document to be copied is on paper larger or smaller than the specified print media size (→ p. 3-6), you can automatically reduce or enlarge the image to fit the selected print media size.

NOTE

- You can only use the platen glass with this feature.

Refer to *Making copies* on p. 5-1 and in step 4, follow this procedure:

1 Press [Enlarge/Reduce] three times.



FIT-TO-PAGE

2 Press [Set].

► Advanced copy features

Copying two pages on a single page

This feature allows you to reduce two pages to fit onto one page.

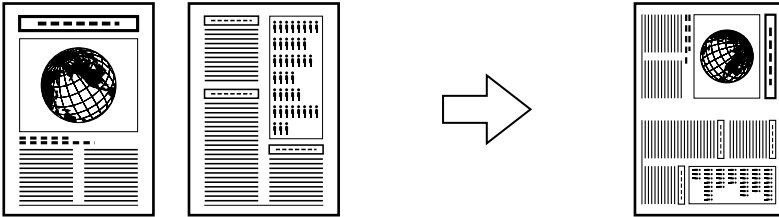

NOTE

- Before using this feature, print or delete any documents in memory you no longer need. This will maximize the amount of memory available for this feature. Also, setting the image quality setting to <B&W TEXT> or <COLOR NORMAL> will use less memory (→ p. 5-1).
- You can only use this feature when the print media size setting is set to <LTR> or <A4>. For details on setting the print media size, see p. 3-6.

Follow this procedure to reduce and copy two originals onto one page:

- 1 Load the document on the platen glass or Fax Model ADF.**
- 2 Press [Copy].**
- 3 Use the numeric keys to enter the number of copies.**
- 4 Adjust any necessary settings for your document (→ step 4, p. 5-1).**
- 5 Press [Menu].**
- 6 Press [Set] twice.**

```
62%  LTR  TEXT  01
2 on 1
```

- If a print media size setting other than <LTR> or <A4> is selected, the LCD will display the following message:

```
Ex: SIZE : < LTR >
TYPE : PLAIN
```

Use [◀] or [▶] to select <LTR> or <A4>, then press [Set].

Use [◀] or [▶] to select the print media type, then press [Set].

- 7 Press [Start].**
If you are using the platen glass, you will be prompted when the page has been scanned. Load the next page and follow the instructions in the LCD.

Borderless copying

This feature allows you to copy colored images that fill the entire page without borders.

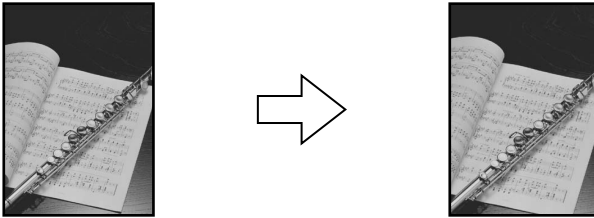

NOTE

- You can only use the platen glass with this feature.
- Use specialty papers with this feature (→ p. 3-1).
- You can only use this feature when the print media size setting is set to <LTR>, <4" × 6">, <5" × 7">, or <A4>. For details on setting the print media size, see p. 3-6. Note that with letter-size paper, a margin may still appear.
- You can only use this feature when the print media type setting is set to <GLOSSY>, <H.RES.>, or <PHOTO>. For details on setting the print media type, see p. 3-6.
- You can only copy in color with this feature.
- Since the image is slightly enlarged to fill the entire page when copied, the image will be slightly cropped at the edges.
- When borderless copying is selected, the LCD will display <100%+>.

Follow this procedure to make a borderless copy:

- 1 Load the document on the platen glass.**
- 2 Press [Copy].**
- 3 Use the numeric keys to enter the number of copies.**
- 4 Adjust any necessary settings for your document (→ step 4, p. 5-1).**
 - The image quality setting is fixed to <COLOR FINE>. You cannot change this setting.
 - You cannot use the [COLOR] or [B&W] key. Copying is fixed to color copying.
- 5 Press [Menu].**
- 6 Press [Set].**

```
SPECIAL COPY
1.2 on 1
```

- 7 Use [◀] or [▶] to select <BORDERLESS COPY>.**
- 8 Press [Set].**

- If a print media size setting other than <LTR>, <4" × 6">, <5" × 7">, or <A4> is selected, or if <PLAIN> or <TRANS.> is selected as the print media type, the LCD will display the following message:

Ex:

```
SIZE : < LTR >
TYPE : PLAIN
```

Use [◀] or [▶] to select either <LTR>, <4" × 6">, <5" × 7">, or <A4>, then press [Set].

Use [◀] or [▶] to select <PHOTO>, <GLOSSY>, or <H.RES.> as the print media type, then press [Set].

9 Press [Start].

NOTE

- You can select the width cropped from the borders of the original image (→ <EXTENSION AMOUNT>, p. 13-5).

Repeating an image on a page

This feature allows you to copy an image several times onto a single page.

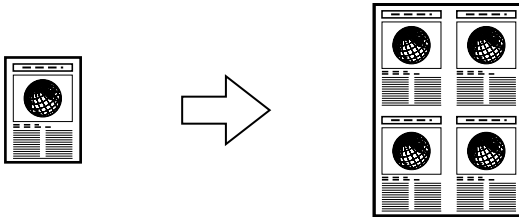

You can set the machine to automatically select the number of times it repeats the image (→ p. 5-7), or you can specify the number (→ below).

Preparing your image to repeat it manually

To successfully repeat an image manually (with the <MANUAL> setting), do the following:

- 1 Set the print media size you will be copying on to (→ p. 3-6).**
- 2 Decide the number of times you want to copy the image. You can have a maximum of four vertical repeats and four horizontal repeats.**
- 3 Your document must be no larger than one of the divisions of the print media. For example, if you want to make four repeats of your image, the document must be no larger than one quarter of the print media size you are copying on to.**

Examples

- 2 × 2 repeats

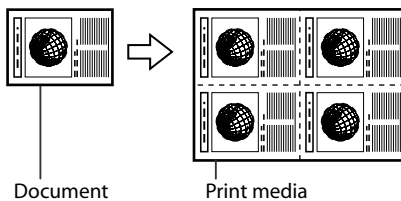

- 3 × 3 repeats

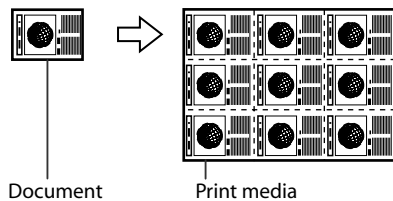

NOTE

- The scanned area of a document also depends on the enlargement/reduction ratio.

You are now ready to start copying.

Copying your image

Follow this procedure to automatically or manually repeat an image on a page:

- 1 Load the document on the platen glass or Fax Model ADF.**
 - Fax Model If you will be selecting the <AUTO> setting to automatically select the number of repeats, load your document on the platen glass. You cannot use the ADF.
- 2 Press [Copy].**
- 3 Use the numeric keys to enter the number of copies.**
- 4 Adjust any necessary settings for your document (→ step 4, p. 5-1).**
- 5 Press [Menu].**
- 6 Press [Set].**

```
SPECIAL COPY
1.2 on 1
```

- 7 Use [◀] or [▶] to select <IMAGE REPEAT>.**

- 8 Press [Set].**

```
IMAGE REPEAT
AUTO
```

- 9 Use [◀] or [▶] to select <AUTO> or <MANUAL>.**

● If you selected <AUTO> in step 9:

- 10 Press [Set].**

Ex:

```
100% LTR TEXT 01
REPEAT AUTO
```

- 11 Press [Start].**

● If you selected <MANUAL> in step 9:

- 10 Press [Set].**

```
VERTICAL < 2 >
HORIZONTAL 2
```

- 11 Use [◀] or [▶] to select the number of vertical repeat (up to 4).**

- 12 Press [Set].**

Ex:

```
VERTICAL 3
HORIZONTAL < 2 >
```

- 13 Use [◀] or [▶] to select the number of horizontal repeat (up to 4).**

- 14 Press [Set].**

Ex:

```
100% LTR TEXT 01
REPEAT 3X3
```

- 15 Press [Start].**

Creating a mirror image

This feature allows you to make a mirror copy of a document. Use this feature when copying onto T-shirt transfers so that the image appears the right way when ironed onto fabric.

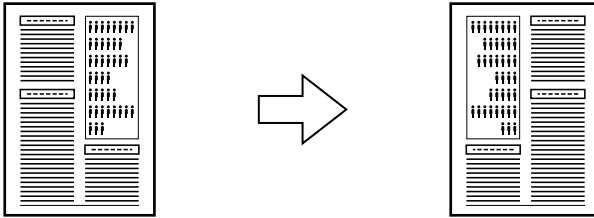

Follow this procedure to make a mirror copy:

- 1 Load the document on the platen glass or Fax Model ADF.**
- 2 Press [Copy].**
- 3 Use the numeric keys to enter the number of copies.**
- 4 Adjust any necessary settings for your document (→ step 4, p. 5-1).**
- 5 Press [Menu].**
- 6 Press [Set].**

SPECIAL COPY
1.2 on 1

- 7 Use [◀] or [▶] to select <MIRROR IMAGE>.**
- 8 Press [Set].**

Ex: 100% LTR TEXT 01
MIRROR

- 9 Press [Start].**

Shrinking an image to fit the page

If the original image fills the entire page, this feature will slightly reduce the image so that it fits on the output print media.

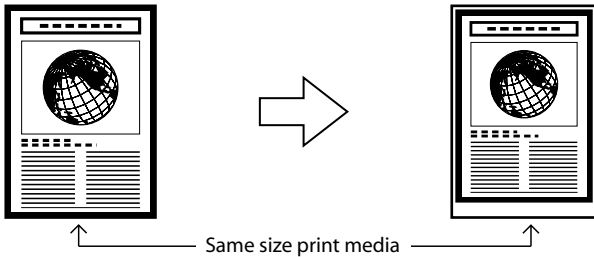

NOTE

- Your original document and the print media loaded in the multi-purpose tray must be the same size. For details on setting the print media size, see p. 3-6.

Follow this procedure to copy an entire image onto a page:

- 1 Load the document on the platen glass or  ADF.**
- 2 Press [Copy].**
- 3 Use the numeric keys to enter the number of copies.**
- 4 Adjust any necessary settings for your document (→ step 4, p. 5-1).**
- 5 Press [Menu].**
- 6 Press [Set].**

```
SPECIAL COPY
1.2 on 1
```

- 7 Use [◀] or [▶] to select <ENTIRE IMAGE>.**
- 8 Press [Set].**

Ex:

```
90% LTR TEXT 01
ENTIRE IMAGE
```

- 9 Press [Start].**

NOTE

- For some documents, the lowermost section of the document may not be copied.

Registering information in your machine

► Guidelines for entering numbers, letters, and symbols

Follow this procedure when you come to a step that requires you to enter a name or number:

1 Press [✳] to switch to letter mode (:A) or number mode (:1).

- You can see what mode you are in by the character indicated on the top right corner of the LCD.



2 Use the numeric keys to enter the character. Press the key repeatedly until the character you want appears.

Key	Letters	Number
[1]		1
[2]	ABCabc	2
[3]	DEFdef	3
[4]	GHIghi	4
[5]	JKLjkl	5
[6]	MNOmno	6
[7]	PQRSpqrs	7
[8]	TUVtuv	8
[9]	WXYZwxyz	9
[0]		0
[#]	-.*#!";:^\`_=/ '?\$@%&+()[]{}<>	

To enter two characters that are under the same key: Press the numeric key, press [▶], then press the same numeric key again. For example, to enter <DD> you would press [3], [▶], [3].

To enter a space: Press [▶].

To delete a character: Press [◀].

To delete an entire entry: Press and hold [◀].

▶ Registering required sender information

In the United States, FCC rules governing the use of facsimile equipment state that your fax/telephone number, personal name or company name, and date and time of transmission must be printed on every facsimile transmission.

Your machine has been designed to print this information at the top of every fax you send.

You must therefore register this information in your machine before using it.

Below is an example of how your sender information will print on a fax sent from your machine:

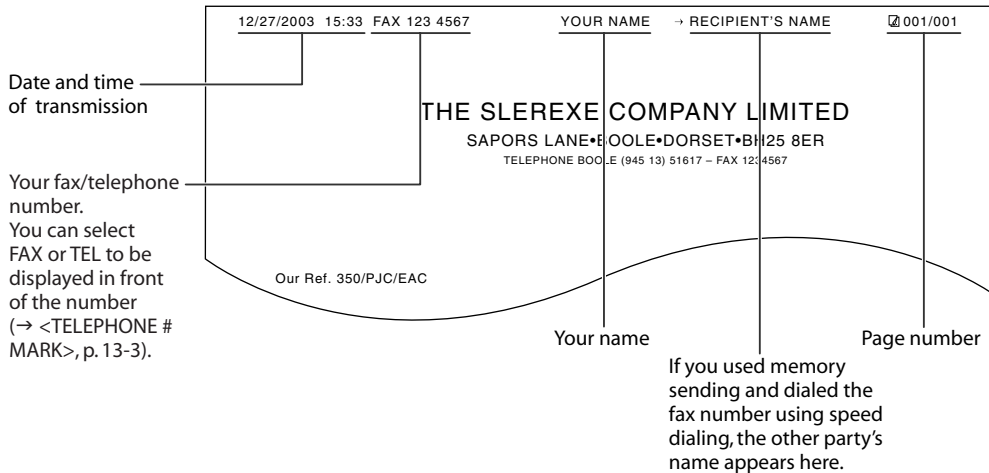

NOTE

- You can set the sender information to print inside or outside the image area (→ <TTI POSITION>, p. 13-3).
- For color sending, the recipient's name is not printed.

Entering the sender information

IMPORTANT

- If your machine is connected to a computer and you start the computer or disconnect and connect the USB cable, the date and time will be read from your computer.

Follow this procedure to enter the sender information:

- 1 Press [Menu].
- 2 Use [◀] or [▶] to select <USER DATA>.
- 3 Press [Set].

```
USER DATA
1.TEL REGISTRATION
```

- 4 Use [◀] or [▶] to select <FAX SETTINGS>.
- 5 Press [Set] three times.

```
DATE & TIME
12/27/2003 15:10
```

- 6 Use the numeric keys to enter the date (month/day/year) and time (in 24-hour format).
 - Enter only the last two digits of the year.

- 7 Press [Set].

```
USER SETTINGS
2.DATE SETUP
```

- 8 Use [◀] or [▶] to select <UNIT TELEPHONE #>.
- 9 Press [Set].

```
UNIT TELEPHONE #
TEL=
```

- 10 Use the numeric keys to enter your fax/telephone number (max. 20 digits, including spaces).
 - To enter a plus sign (+) before the number, press [#].
 - For details on how to enter or delete numbers, see p. 6-1.

- 11 Press [Set] twice.

```
UNIT NAME : A
_
```

- 12 Use the numeric keys to enter your name (max. 24 characters, including spaces).
 - For details on how to enter or delete characters, see p. 6-1.

- 13 Press [Set].

- 14 Press [Stop/Reset].

NOTE

- You can print the USER'S DATA LIST to check the sender information you have registered (→ p. 10-5).

► Setting the telephone line type

Before using your machine, make sure you have set the correct telephone line type for your telephone line. If you are unsure of your telephone line type, contact your telephone company. For ISDN or ADSL connections, contact the telephone company or service provider to confirm your line type.

NOTE

- You can print the USER'S DATA LIST to check the current setting (→ p. 10-5).

Follow this procedure to set the telephone line type:

- 1 Press [Menu].**
- 2 Use [◀] or [▶] to select <USER DATA>.**
- 3 Press [Set].**

```
USER DATA
1.TEL REGISTRATION
```

- 4 Use [◀] or [▶] to select <FAX SETTINGS>.**
- 5 Press [Set] twice.**

```
USER SETTINGS
1.DATE & TIME
```

- 6 Use [◀] or [▶] to select <TEL LINE TYPE>.**
- 7 Press [Set].**

Ex:

```
TEL LINE TYPE
TOUCH TONE
```

- 8 Use [◀] or [▶] to select the telephone line type.**
 - Select:
 - <TOUCH TONE> for tone dialing.
 - <ROTARY PULSE> for pulse dialing.
- 9 Press [Set].**
- 10 Press [Stop/Reset].**

► Setting daylight saving

You can set your machine to automatically change the time for daylight saving by registering the day and time that daylight saving begins and ends.

Follow this procedure to enable/disable the daylight saving.

- 1 Press [Fax].**
- 2 Press [Menu].**
- 3 Use [◀] or [▶] to select <USER DATA>.**
- 4 Press [Set].**

USER DATA
1.TEL REGISTRATION

- 5 Use [◀] or [▶] to select <SYSTEM SETTINGS>.**
- 6 Press [Set].**

SYSTEM SETTINGS
1.AUDIBLE TONES

- 7 Use [◀] or [▶] to select <DAYLGH T SAV TIME>.**
- 8 Press [Set].**

Ex: DAYLGH T SAV TIME
ON

- 9 Use [◀] or [▶] to select <ON> to enable daylight saving or <OFF> to disable it.**

● If you selected <OFF> in step 9:

- 10 Press [Set].**

● If you selected <ON> in step 9:

- 10 Press [Set] three times.**

Ex: MONTH
APRIL

- 11 Use [◀] or [▶] to select the month when daylight saving starts.**

- 12 Press [Set] twice.**

Ex: WEEK
FIRST WEEK

- 13 Use [◀] or [▶] to select the week when daylight saving starts.**

• Select from the following:

- <FIRST WEEK>
- <SECOND WEEK>
- <THIRD WEEK>
- <FOURTH WEEK>
- <LAST WEEK> (fourth or fifth week depending on the month)

14 Press [Set] twice.

Ex:

DAY	SUNDAY
-----	--------

15 Use [◀] or [▶] to select the day when daylight saving starts.

16 Press [Set] twice.

Ex:

TIME	02:00
------	-------

17 Use the numeric keys to enter the time (in 24-hour format) when daylight saving compensation is made.

- Precede single digits with a zero.

18 Press [Set] three times.

Ex:

MONTH	OCTOBER
-------	---------

19 Use [◀] or [▶] to select the month when daylight saving ends.

20 Press [Set] twice.

Ex:

WEEK	FIRST WEEK
------	------------

21 Use [◀] or [▶] to select the week when daylight saving ends.

- Select from the following:
 - <FIRST WEEK>
 - <SECOND WEEK>
 - <THIRD WEEK>
 - <FOURTH WEEK>
 - <LAST WEEK> (fourth or fifth week depending on the month)

22 Press [Set] twice.

Ex:

DAY	SUNDAY
-----	--------

23 Use [◀] or [▶] to select the day when daylight saving ends.

24 Press [Set] twice.

Ex:

TIME	02:00
------	-------

25 Use the numeric keys to enter the time (in 24-hour format) when daylight saving compensation is made.

- Precede single digits with a zero.

26 Press [Set].

Speed dialing

► Speed dialing methods

Speed dialing allows you to dial fax/telephone numbers by simply pressing one or a few keys.

The following speed dialing methods are available:

- **One-touch speed dialing**

Register a fax/telephone number for one-touch speed dialing (→ p. 7-2), then to dial the number, simply press the one-touch speed dialing key assigned to that number.

- **Coded speed dialing**

Register a fax/telephone number for coded speed dialing (→ p. 7-4), then to dial the number, simply press [Coded Dial] and enter the two-digit code assigned to that number.

- **Group dialing**

Register a group of fax numbers for group dialing (→ p. 7-6), then to send a document to all numbers in that group, simply press the one-touch speed dialing key, or press [Coded Dial] and enter the two-digit code assigned to that group.

► Registering one-touch speed dialing

Before you can use one-touch speed dialing (→ p. 7-8), you need to register the recipients' numbers. Follow this procedure:

- 1 Press [Menu].**
- 2 Use [◀] or [▶] to select <USER DATA>.**
- 3 Press [Set] three times.**

```
1-TOUCH SPD DIAL
01=
```

- 4 Use [◀] or [▶] to select a one-touch speed dialing key (01 to 10).**
 - You can also select a key by pressing the one-touch speed dialing key.

- 5 Press [Set] twice.**

```
TELEPHONE NUMBER
TEL= _
```

- 6 Use the numeric keys to enter the fax/telephone number you want to register (max. 120 digits, including spaces and pauses).**
 - For details on how to enter or delete numbers, see p. 6-1.

- 7 Press [Set] twice.**

```
NAME : A
_
```

- 8 Use the numeric keys to enter a name for the one-touch speed dialing key (max. 16 characters, including spaces).**
 - For details on how to enter or delete characters, see p. 6-1.

- 9 Press [Set].**

- 10 To continue registering one-touch speed dialing keys, repeat the procedure from step 4.**

-or-

Press [Stop/Reset] to return to standby mode.

NOTE

- Use the destination labels provided with your machine to label the one-touch speed dialing keys with the recipients' names.
- For a list of the recipients you have registered, print the one-touch speed dialing list (→ p. 7-9).

Changing or deleting an entry

Follow the procedure for registering one-touch speed dialing (→ p. 7-2), and do the following:

To change a registered number: In step 6, use [◀] to delete the registered number, then use the numeric keys to enter the new number.

To change a registered name: In step 8, use [◀] to delete the registered name, then use the numeric keys to enter the new name.

To delete an entire entry: In step 6, press and hold [◀] to clear the registered number, press [Set], then [Stop/Reset]. The name will automatically be deleted when you delete the number.

► Registering coded speed dialing

Before you can use coded speed dialing (→ p. 7-8), you need to register the recipients' numbers. Follow this procedure:

- 1 Press [Menu].
- 2 Use [◀] or [▶] to select <USER DATA>.
- 3 Press [Set] twice.

```
TEL REGISTRATION
1.1-TOUCH SPD DIAL
```

- 4 Use [◀] or [▶] to select <CODED SPEED DIAL>.
- 5 Press [Set].

```
CODED SPEED DIAL
*00=
```

- 6 Use [◀] or [▶] to select a coded speed dialing code (00 to 99).
 - You can also select a code by pressing [Coded Dial] and then using the numeric keys to enter a two-digit code.

- 7 Press [Set] twice.

```
TELEPHONE NUMBER
TEL= _
```

- 8 Use the numeric keys to enter the fax/telephone number you want to register (max. 120 digits, including spaces and pauses).
 - For details on how to enter or delete numbers, see p. 6-1.

- 9 Press [Set] twice.

```
NAME : A
_
```

- 10 Use the numeric keys to enter a name for the coded speed dialing code (max. 16 characters, including spaces).
 - For details on how to enter or delete characters, see p. 6-1.

- 11 Press [Set].

- 12 To continue registering coded speed dialing codes, repeat the procedure from step 6.
-or-
Press [Stop/Reset] to return to standby mode.

NOTE

- For a list of the recipients you have registered, print the coded speed dialing list (→ p. 7-9).

Changing or deleting an entry

Follow the procedure for registering coded speed dialing (→ p. 7-4), and do the following:

To change a registered number: In step 8, use [◀] to delete the registered number, then use the numeric keys to enter the new number.

To change a registered name: In step 10, use [◀] to delete the registered name, then use the numeric keys to enter the new name.

To delete an entire entry: In step 8, press and hold [◀] to clear the registered number, press [Set], then [Stop/Reset]. The name will automatically be deleted when you delete the number.

► Registering group dialing

Before you can use group dialing (→ p. 7-8), you need to register the recipients' numbers. Follow this procedure:

NOTE

- You can only group numbers that have already been registered for one-touch or coded speed dialing (→ pp. 7-2, 7-4).

- 1 Press [Menu].
- 2 Use [◀] or [▶] to select <USER DATA>.
- 3 Press [Set] twice.

```
TEL REGISTRATION
1.1-TOUCH SPD DIAL
```

- 4 Use [◀] or [▶] to select <GROUP DIAL>.
- 5 Press [Set].

```
GROUP DIAL
01=
```

- 6 Select a one-touch speed dialing key or coded speed dialing code under which you want to register the group.
 - To register a group under a one-touch speed dialing key:
Use [◀] or [▶] to select an empty key (01 to 10).
 - To register a group under a coded speed dialing code:
Press [Coded Dial], then use the numeric keys to enter an empty two-digit code (00 to 99).
- 7 Press [Set] twice.

```
TEL=
```

- 8 Enter the one-touch and/or coded speed dialing numbers you want to register in the group.
 - To enter a one-touch speed dialing entry: Press the one-touch speed dialing key(s).
 - To enter a coded speed dialing entry: Press [Coded Dial], then use the numeric keys to enter the code(s).
 - You can only enter numbers that have already been registered for one-touch or coded speed dialing (i.e. you cannot enter numbers with the numeric keys).
 - To review the numbers you have entered, use [◀] or [▶].
- 9 Press [Set] twice.

```
NAME : A
_
```

10 Use the numeric keys to enter a name for the group (max. 16 characters, including spaces).

- For details on how to enter or delete characters, see p. 6-1.
- The name you enter here will appear in speed dialing lists.

11 Press [Set].

12 To continue registering other groups, repeat the procedure from step 6.

-or-

Press [Stop/Reset] to return to standby mode.

 **NOTE**

- For a list of the entries you have made, print the group dialing list (→ p. 7-9).

Changing or deleting an entry

Follow the procedure for registering groups (→ p. 7-6), and do the following:

To delete a number from the group: In step 8, use [◀] or [▶] to display the number you want to delete, then press and hold [◀].

To add a number to the group: In step 8, simply enter the number as explained.

To delete an entire group: In step 8, press and hold [◀] until all numbers are deleted, press [Set], then [Stop/Reset]. The name for the group will automatically be deleted when you delete the numbers.

► Using speed dialing

Using speed dialing is easy. Simply do the following when you want to dial a number or group registered for speed dialing:

● One-touch speed dialing:

- 1 Press the one-touch speed dialing key assigned to the number you want to dial (01 to 10).



● Coded speed dialing:

- 1 Press [Coded Dial].

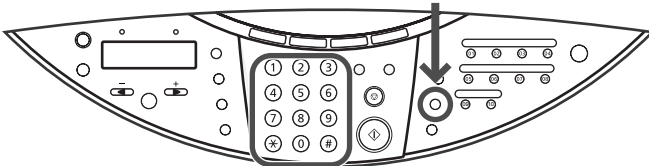

- 2 Use the numeric keys to enter the two-digit code assigned to the number you want to dial (00 to 99).

- **For a group registered for one-touch speed dialing:** Press the one-touch speed dialing key assigned to the group you want to dial (see *One-touch speed dialing* above).
- **For a group registered for coded speed dialing:** Press [Coded Dial], then use the numeric keys to enter the two-digit code assigned to the group you want to dial (see *Coded speed dialing* above).

If you use speed dialing to send a fax, press [Start] after dialing, or wait a few seconds for the machine to automatically begin scanning your document for sending. If you do not want the machine to begin scanning automatically, disable the <TIME OUT> setting (→ p. 13-4).

► Printing speed dialing lists

You can print lists of the recipients registered for speed dialing. You may want to keep these lists near your machine to refer to them when dialing.

Follow this procedure to print speed dialing lists:

- 1 Press [Fax].
- 2 Press [Menu].
- 3 Use [◀] or [▶] to select <REPORTS/LISTS>.
- 4 Press [Set].

```
REPORTS/LISTS
1.ACTIVITY REPORT
```

- 5 Use [◀] or [▶] to select <SPEED DIAL LIST>.
- 6 Press [Set].

```
SPEED DIAL LIST
1.1-TOUCH LIST
```

- 7 Use [◀] or [▶] to select the list you want to print.

- Select from the following:

- <1-TOUCH LIST>
- <CODED DIAL LIST>
- <GROUP DIAL LIST>

- 8 Press [Set].

If you selected <1-TOUCH LIST> or <CODED DIAL LIST> above, select in what order you want the destinations to be printed. Press [*] to print the list with the destination names in alphabetical order, or press [#] to print the list in code or key order.

Sending faxes

► Documents you can fax

For information on the types of documents you can fax, their requirements, and details on loading them, see Chapter 2.

► Sending methods

There are two methods of sending faxes from your machine:

- Memory sending (→ below)
- Manual sending (→ p. 8-2)

Memory sending

You should normally use memory sending to send documents fast and efficiently.

Follow this procedure for memory sending:

- 1 Load the document on the platen glass or ADF.**
 - For details on how to load documents, see p. 2-2.
- 2 Press [Fax].**
- 3 Adjust any necessary settings for your document.**
 - Press [Color] for color sending, or [B&W] for black & white sending (→ p. 8-3).
 - Press [Image Quality] to select the fax resolution (→ p. 8-3).
 - Press [Exposure] to select the scan exposure (→ p. 8-4).
- 4 Dial the recipient's number.**
 - For details on the different dialing methods, see p. 8-4.
- 5 Press [Start].**

If you are using the platen glass, you will be prompted when the page has been scanned. Load the next page (for a multipage document) and press [Start]. To start sending, press [Set].

To cancel memory sending: Press [Stop/Reset] and follow any instructions in the LCD.

Manual sending

Use manual sending when you want to talk to the recipient before sending a document, or if the recipient does not have a fax machine that can receive automatically.

 **NOTE**

- With manual sending, you cannot use the platen glass to send documents.
- You will need to connect a telephone to your machine if you want to talk to the recipient before sending a document.

Follow this procedure for manual sending:

- 1 Connect a telephone to your machine if you want to talk to the recipient before sending a document (→ *Set-Up Sheet*).**
- 2 Load the document in the ADF.**
 - For details on how to load documents in the ADF, see p. 2-2.
- 3 Press [Fax].**
- 4 Adjust any necessary settings for your document.**
 - Press [Color] for color sending, or [B&W] for black & white sending (→ p. 8-3).
 - Press [Image Quality] to select the fax resolution (→ p. 8-3).
 - Press [Exposure] to select the scan exposure (→ p. 8-4).
- 5 Press [Hook] or lift the handset.**
- 6 Dial the recipient's number.**
 - For details on the different dialing methods, see p. 8-4.
- 7 Talk through the handset to the recipient.**
 - If you hear a high-pitched signal instead of the recipient's voice, go to step 9.
- 8 Ask the recipient to set his fax machine to receive faxes.**
- 9 When you hear a high-pitched signal, press [Start] and then hang up the handset.**

To cancel manual sending: Press [Stop/Reset].

► Improving faxed images

There are several settings that allow you to improve the quality of faxed documents.

Setting color or black & white transmission

Follow the procedure for sending a document (→ p. 8-1) and set color or black & white sending as follows when required to do so:

For color sending: Press [Color] to turn on its light.

For black & white sending: Press [B&W] to turn on its light.

The setting automatically reverts to black & white after a document is sent or canceled.

NOTE

- If you attempt to send a color document to a fax machine that does not support color faxing, you will get an error message. Try sending again in black & white. Alternatively, if you are sending from the ADF, you can enable the <COLOR DIRECT TX> setting (→ p. 13-4) that will send a color document in black & white if the recipient's fax machine does not support color faxing.

Adjusting the image quality (fax resolution)

You can adjust the image quality (fax resolution) of the document you send. The higher the image quality, the better the output quality at the other end, but the slower the transmission speed. Adjust the image quality according to the type of document you are sending.

Follow the procedure for sending a document (→ p. 8-1) and adjust the image quality as follows when required to do so:

- 1 Press [Image Quality].**
- 2 Use [◀] or [▶] to select the resolution.**
 - In black & white mode, select:
 - <B&W STANDARD> for text-only documents.
 - <B&W FINE> for fine-print documents.
 - <B&W PHOTO> for photographs.
 - In color mode select:
 - <COLOR STANDARD> for normal color documents.
 - <COLOR FINE> for fine color documents.
- 3 Press [Set].**

Adjusting the scan exposure

Exposure is the degree of difference between light and dark. A high exposure setting will make blacks darker and whites brighter, whereas a low exposure setting will make the differences between black and white less marked.

Follow the procedure for sending a document (→ p. 8-1) and adjust the exposure as follows when required to do so:

- 1 Press [Exposure].**
- 2 Use [◀] or [▶] to select the exposure.**
- 3 Press [Set].**

▶ Dialing methods

There are several methods of dialing the number of the recipient:

- **Regular dialing**

Simply dial the number using the numeric keys.

- **One-touch speed dialing**

Register a number for one-touch speed dialing so that you only have to press one key to dial that number. For details on registering and using one-touch speed dialing, see Chapter 7.

- **Coded speed dialing**

Register a number for coded speed dialing so that you only have to press [Coded Dial] and then enter the two-digit code assigned to that number. For details on registering and using coded speed dialing, see Chapter 7.

- **Group dialing**

Register numbers for group dialing so that you can send a document to a predefined group of fax numbers using speed dialing. For details on registering and using group dialing, see Chapter 7.

- **PC dialing**

Dial a fax number from your computer using the software. For details, see the *Software Guide*.

► Redialing a busy number

There are two methods of redialing: *Manual redialing* and *Automatic redialing*.

Manual redialing

Press [Redial/Pause] to redial the last number entered with the numeric keys.

To cancel manual redialing: Press [Stop/Reset].

Automatic redialing

When using memory sending to send a document and the recipient's line is busy, your machine will redial the number after an interval.

Your machine allows you to customize automatic redialing settings to suit your needs (see below).

To cancel automatic redialing: Wait until the machine starts redialing, then press [Stop/Reset]. Follow the instructions in the LCD.

NOTE

- You can also delete the document from memory. For details, see p. 8-8.

Customizing automatic redialing settings

You can customize the following settings:

- Whether or not your machine redials automatically
- The number of times the machine redials
- The time interval between redialings

Follow this procedure to customize automatic redialing settings:

- 1 Press [Menu].**
- 2 Use [◀] or [▶] to select <USER DATA>.**
- 3 Press [Set].**

```
USER DATA
1.TEL REGISTRATION
```

- 4 Use [◀] or [▶] to select <FAX SETTINGS>.**
- 5 Press [Set].**

```
FAX SETTINGS
1.USER SETTINGS
```

- 6 Use [◀] or [▶] to select <TX SETTINGS>.**
- 7 Press [Set].**

```
TX SETTINGS
1.ECM TX
```

8 Use [**◀**] or [**▶**] to select <AUTO REDIAL>.

9 Press [Set].

AUTO REDIAL
ON

10 Use [**◀**] or [**▶**] to select <ON> to enable automatic redialing or <OFF> to disable it.

● If you selected <OFF> in step 10:

11 Press [Set].

12 Press [Stop/Reset].

● If you selected <ON> in step 10:

11 Press [Set] twice.

REDIAL TIMES
2TIMES

12 Use the numeric keys to enter the number of times you want the machine to redial.

13 Press [Set] twice.

REDIAL INTERVAL
2MIN.

14 Use the numeric keys to enter the time interval between redialings.

15 Press [Set].

16 Press [Stop/Reset].

► Sending the same document to several recipients (sequential broadcasting)

Your machine allows you to send the same document to a maximum of 111 recipients in one operation. You can dial the recipients' numbers using any of the following dialing methods:

- One-touch speed dialing: up to 10 destinations
- Coded speed dialing: up to 100 destinations
- Regular dialing (using the numeric keys) or redialing: one destination

You can enter the destinations in any order, but be sure to press [Set] after your entry with the numeric keys.

NOTE

- If you frequently send documents to the same group of recipients, you can group these numbers for group dialing. This will allow you to send documents to all recipients in the group at the press of one or a few keys (→ p. 7-6).

Follow this procedure to send the same document to several recipients:

- 1 Load the document on the platen glass or ADF.**
 - For details on how to load documents, see p. 2-2.
- 2 Press [Fax].**
- 3 Adjust any necessary settings for your document.**
 - Press [Color] for color sending, or [B&W] for black & white sending (→ p. 8-3).
 - Press [Image Quality] to select the fax resolution (→ p. 8-3).
 - Press [Exposure] to select the scan exposure (→ p. 8-4).
- 4 Enter the fax numbers you want to send to.**
 - **One-touch speed dialing:** Press the one-touch speed dialing key(s).
 - **Coded speed dialing:** Press [Coded Dial], then use the numeric keys to enter the two-digit code(s).
 - **Regular dialing:** Use the numeric keys to enter the fax number, then press [Set].
 - You must enter the second fax number within five seconds of entering the first fax number. All subsequent fax numbers must each be entered within 10 seconds. If you wait longer than these times, the machine will automatically begin scanning the document for sending. If you prefer the machine not to do this, disable the <TIME OUT> setting (→ p. 13-4).
 - To review the numbers you have entered, use [◀] or [▶].
- 5 Press [Start].**

If you are using the platen glass, you will be prompted when the page has been scanned. Load the next page (for a multipage document) and press [Start]. To start sending, press [Set].

To cancel sending: Press [Stop/Reset] and follow the instructions in the LCD. When you press [Stop/Reset], sending to all recipients will be canceled. You cannot cancel sending to only one recipient.

► Documents stored in memory

NOTE

- If there are no documents stored in memory, the machine will revert to standby mode when you select <MEMORY REFERENCE>.

Printing a list of documents in memory

The machine can print a list of documents stored in memory (DOC. MEMORY LIST) showing the transaction number (TX/RX NO), transaction mode, recipient name, number of pages, date, and set time of each document. This will help you select a document in memory you wish to delete or print.

Follow this procedure to print a list of documents in memory:

- 1 Press [Fax].**
- 2 Press [Menu].**
- 3 Use [◀] or [▶] to select <MEMORY REFERENCE>.**
- 4 Press [Set] twice.**

NOTE

- You can also print this list from the <DOC. MEMORY LIST> setting in the <REPORTS/LISTS> menu (→ p. 13-6).

Printing or deleting a document in memory

Follow this procedure to print or delete a document in memory:

- 1 Press [Fax].**
- 2 Press [Menu].**
- 3 Use [◀] or [▶] to select <MEMORY REFERENCE>.**
- 4 Press [Set].**

```
MEMORY REFERENCE
1.DOC. MEMORY LIST
```

- 5 Use [◀] or [▶] to select <PRINT DOCUMENT> or <DELETE DOCUMENT>.**
- 6 Press [Set].**

```
PRINT DOCUMENT
TX/RX NO.      0001
```

- 7 Use [◀] or [▶] to select the transaction number (TX/RX NO.) of the document you want to print or delete.**
 - If you are unsure of the transaction number, print the DOC. MEMORY LIST (→ *Printing a list of documents in memory*, above).
 - To interpret the LCD message, see *Checking a document's details* on p. 8-9.
- 8 Press [Set].**

- 9**
- If printing a document, press [*****] to print the first page only, or [**#**] to print all pages of the document.
 - If deleting a document, press [*****].
- 10** To continue printing or deleting other documents in memory, repeat the procedure from step 7.
- or-
- Press [**Stop/Reset**] to return to standby mode.

Checking a document's details

When you have to select a document in memory to be printed or deleted, you can check its details in the LCD as follows:

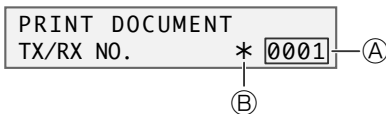

Ⓐ Transaction number (TX/RX NO.)

- A transaction number between 0001 and 4999 is a document to be sent.
- A transaction number between 5001 and 9999 is a received document.

Ⓑ Marks before the transaction number

- No mark indicates a black & white document.
- <*> indicates a color document.
- <#> indicates a black & white document being sent or printed.
- <&> indicates a color document being sent or printed.

Displaying details of the transaction

Use [*****] or [**#**] to display the details (e.g. destination).

NOTE

- If you are unsure of the transaction number, print the DOC. MEMORY LIST (→ *Printing a list of documents in memory*, p. 8-8).

► Special dialing

Dialing through a switchboard

A PBX (Private Branch Exchange) is an on-site telephone switchboard. If your machine is connected through a PBX or other telephone switching system, you have to dial the outside line access number first, and then the number of the party you are calling.

Switching temporarily to tone dialing

Many information services for banks, airline reservations, hotel reservations, etc. require tone dialing for their services. If your machine is connected to a rotary pulse line, follow this procedure to set the machine temporarily for tone dialing:

- 1 Press [Fax].**
- 2 Press [Hook] or lift the handset if you have connected a telephone to your machine.**
- 3 Use the numeric keys to dial the number of the information service.**
- 4 When the recorded message of the information service answers, press [Tone] ([*]) to switch to tone dialing.**
 - If you pressed [Hook] in step 2, you can pick up the handset if you need to talk to the other party.
- 5 Use the numeric keys to enter the numbers requested by the information service.**
- 6 When you have finished, press [Hook] or hang up the handset.**

Receiving faxes

► Setting the receive mode

Follow this procedure to set the receive mode:

- 1 Press [Fax].
- 2 Press [Menu].
- 3 Press [Set].

```
RECEIVE MODE
FAX/TEL AUTO SW
```

4 Use [◀] or [▶] to select the receive mode:

- Select:
 - <FAX/TEL AUTO SW> to automatically switch between fax and voice calls. Faxes will be received automatically, and the machine will ring for voice calls. * A phone connected to your machine will not ring.
 - <FAX ONLY MODE> to automatically receive faxes only. Voice calls will be disconnected.
 - <DRPD> if you have subscribed to a DRP (Distinctive Ring Pattern) service offered by some companies.
 - <MANUAL MODE> for the machine to ring for fax and voice calls. Fax calls must be answered manually.
 - <ANS.MACHINE MODE> to receive faxes automatically and route voice calls to an answering machine connected to your machine.

5 Press [Set].

- The receive mode will be displayed on the bottom left of the LCD.

```
12/27/2003 SAT 15:30
FaxTel STANDARD
```

► Receiving both faxes and voice calls automatically: FAX/TEL AUTO SW

- **Choose this mode if:**

- you only have one telephone line for both fax and telephone use.
- you want to receive faxes automatically as well as voice calls.

- **You will need to:**

- set <FAX/TEL AUTO SW> (→ p. 9-1).
- connect a telephone to your machine (→ *Set-Up Sheet*).

- **When you receive a fax call:** The machine will receive the fax automatically.

- **When you receive a voice call:** The machine will ring. Pick up the handset to answer the call.

* A phone connected to your machine will not ring.

Customizing FAX/TEL AUTO SW

You can customize this mode to control precisely how your machine handles incoming calls. You can adjust the time the machine takes to check whether a call is a fax or voice call, the length of time the machine rings when it is a voice call, and the action the machine must take if no one answers a voice call.

Follow this procedure to customize <FAX/TEL AUTO SW>:

- 1 Press [Menu].**
- 2 Use [◀] or [▶] to select <USER DATA>.**
- 3 Press [Set].**

```
USER DATA
1.TEL REGISTRATION
```

- 4 Use [◀] or [▶] to select <FAX SETTINGS>.**
- 5 Press [Set].**

```
FAX SETTINGS
1.USER SETTINGS
```

- 6 Use [◀] or [▶] to select <RX SETTINGS>.**
- 7 Press [Set].**

```
RX SETTINGS
1.ECM RX
```

- 8 Use [◀] or [▶] to select <FAX/TEL AUTO SW>.**
- 9 Press [Set] twice.**

```
RING START TIME
8SEC
```

- 10 Use [◀] or [▶] to select the time the machine takes to check whether a call is a fax or voice call.**

11 Press [Set] twice.

F/T RING TIME 15SEC

12 Use [◀] or [▶] to select the length of time the machine rings when the call is a voice call.

13 Press [Set] twice.

DEFAULT ACTION RECEIVE

14 Use [◀] or [▶] to select whether the machine switches to receive mode or disconnects the call if no one answers a voice call after the specified time in step 12.

- Select:
 - <RECEIVE> to switch to receive mode.
 - <DISCONNECT> to disconnect the call.

15 Press [Set].

16 Press [Stop/Reset].

► Receiving faxes automatically: FAX ONLY MODE

● **Choose this mode if:**

- you have a dedicated telephone line for fax use only.
- you only want to receive faxes automatically with your machine.

● **You will need to:**

- connect your machine to a dedicated telephone line (→ *Set-Up Sheet*).
- set <FAX ONLY MODE> (→ p. 9-1).

● **When you receive a fax call:** The machine will receive the fax automatically.

● **When you receive a voice call:** You will not be able to answer the call.

 **NOTE**

- The machine does not ring when it receives a fax call. If you want it to ring, connect a telephone to your machine and enable the <INCOMING RING> setting (→ p. 13-5). You can also select the number of rings before the machine answers (→ <RING COUNT>, p. 13-5).

► Receiving with a DRPD (Distinctive Ring Pattern Detection) service: DRPD

- **Choose this mode if:**

- you only have one telephone line for both fax and telephone use.
- you want to receive faxes automatically as well as voice calls.
- you have subscribed to a DRPD (Distinctive Ring Pattern Detection) service with your telephone company. This service assigns two or more telephone numbers with distinctive ring patterns to a single telephone line, allowing you to have both a fax number(s) and a telephone number(s) using only one telephone line. Your machine will automatically monitor incoming calls and based on the ring pattern, will let you know if the call is a fax or voice call. Contact your telephone company for more information on this service.

- **You will need to:**

- set <DRPD> (→ p. 9-1).
- connect a telephone to your machine (→ *Set-up Sheet*).

- **When you receive a fax call:** The machine will ring according to the ring pattern you have chosen and receive the fax automatically.

- **When you receive a voice call:** The machine will ring according to the ring pattern you have chosen. Pick up the handset to answer the call.

Setting the ring pattern

Your telephone company will assign a distinctive ring pattern to each number when you order the DRPD service. Follow this procedure to set the fax ring pattern that matches the pattern assigned by the telephone company:

1 Make sure you have set <DRPD> (→ p. 9-1).

2 Press [Menu].

3 Use [◀] or [▶] to select <USER DATA>.

4 Press [Set].

```
USER DATA
1.TEL REGISTRATION
```

5 Use [◀] or [▶] to select <FAX SETTINGS>.

6 Press [Set].

```
FAX SETTINGS
1.USER SETTINGS
```

7 Use [◀] or [▶] to select <RX SETTINGS>.

8 Press [Set].

```
RX SETTINGS
1.ECM RX
```

9 Use [◀] or [▶] to select <DRPD:SELECT FAX>.

10 Press [Set].

DRPD:SELECT FAX
DOUBLE RING

11 Use [◀] or [▶] to select the ring pattern that your telephone company assigned to your fax number.

- Select from the following:
 - <DOUBLE RING>
 - <SHORT-SHORT-LONG>
 - <SHORT-LONG-SHORT>
 - <OTHER RING TYPE>
 - <NORMAL RING>

12 Press [Set].

13 Press [Stop/Reset].

► Receiving faxes manually: MANUAL MODE

● Choose this mode if:

- you only have one telephone line for both fax and telephone use.
- you receive mainly voice calls and sometimes faxes.

● You will need to:

- set <MANUAL MODE> (→ p. 9-1).
- connect a telephone to your machine (→ *Set-Up Sheet*).

- **When you receive a fax call:** The machine will ring. Pick up the handset and if you hear a beep, press [Start] on the machine to receive the fax. If you are far from your machine, dial 25 (the remote receiving ID) on your telephone and hang up.

- **When you receive a voice call:** The machine will ring. Pick up the handset to answer the call.

NOTE

- You can customize remote receiving by enabling/disabling it, or by changing the remote receiving ID (→ <REMOTE RX>, p. 13-5).
- If you have an answering machine connected to your machine that can carry out remote-control operations (controlling your answering machine from a remote telephone), the security code for this function may be the same as the remote receiving ID. If so, make sure you change the machine's remote receiving ID to make it distinct from the answering machine's security code (→ <REMOTE RX ID>, p. 13-5).

► Receiving when an answering machine is connected: ANS.MACHINE MODE

- **Choose this mode if:**

- you only have one telephone line for both fax and telephone use.
- you want to receive faxes automatically and receive voice messages on your answering machine.

- **You will need to:**

- set <ANS.MACHINE MODE> (→ p. 9-1).
- connect an answering machine to your machine (→ *Set-Up Sheet*).

- **When you receive a fax call:** The machine will receive the fax automatically.

- **When you receive a voice call:** The answering machine will record any voice messages.

Adjusting the answering machine

Adjust your answering machine as follows:

- Set the answering machine to answer on the first or second ring.
- The entire message should be no longer than 15 seconds.
- In the message, tell your callers how to send a fax.

► Canceling receiving

Press [Stop/Reset] and follow any instructions in the LCD.

Reports and lists

► Summary of reports and lists

The table below shows the reports and lists that can be printed from your machine. Refer to the pages indicated for more details.

Report or List	Description	Details
USER'S DATA LIST	Lists the current settings of your machine and the registered sender information.	p. 10-5
ACTIVITY REPORT	Shows recent facsimile transactions performed by your machine. You can enable or disable automatic printing of this report after every 20 transactions. You can also manually set the machine to print it.	p. 10-2
TX (Transmission) REPORT	Prints after transmission of a document. You can enable or disable this feature, or set the machine to print a report only when an error occurs. You can also set the machine to print the first page of the document under the transmission report to remind you of the contents of the document.	p. 10-3
RX (Reception) REPORT	Prints after reception of a document. You can enable or disable this feature, or set the machine to print a report only when an error occurs.	p. 10-4
MULTI TX/RX (Transaction) REPORT	Prints after sequential broadcasting of a document.	
DOC. MEMORY LIST	Lists the documents currently stored in the machine's memory.	p. 8-8
MEMORY CLEAR REPORT	Prints automatically when power is restored to the machine after a power failure. Lists the documents deleted from memory.	p. 12-15
1-TOUCH SPD DIAL LIST	Lists the numbers and names registered for one-touch speed dialing.	p. 7-9
CODED SPEED DIAL LIST	Lists the numbers and names registered for coded speed dialing.	p. 7-9
GROUP DIAL LIST	Lists groups registered for group dialing.	p. 7-9

▶ ACTIVITY REPORT

Printing the ACTIVITY REPORT

The machine is factory-set to print an ACTIVITY REPORT after every 20 transactions. If you want to print an ACTIVITY REPORT before it is automatically printed, follow this procedure:

- 1 Press [Fax].
- 2 Press [Menu].
- 3 Use [◀] or [▶] to select <REPORTS/LISTS>.
- 4 Press [Set] twice.

Adjusting the ACTIVITY REPORT setting

If you do not want the machine to automatically print an ACTIVITY REPORT after every 20 transactions, disable the <ACTIVITY REPORT> setting.

Follow this procedure to adjust this setting:

- 1 Press [Menu].
- 2 Use [◀] or [▶] to select <USER DATA>.
- 3 Press [Set].

```
USER DATA
1.TEL REGISTRATION
```

- 4 Use [◀] or [▶] to select <FAX SETTINGS>.
- 5 Press [Set].

```
FAX SETTINGS
1.USER SETTINGS
```

- 6 Use [◀] or [▶] to select <REPORT SETTINGS>.
- 7 Press [Set].

```
REPORT SETTINGS
1.TX REPORT
```

- 8 Use [◀] or [▶] to select <ACTIVITY REPORT>.
- 9 Press [Set].

```
ACTIVITY REPORT
AUTO PRINT ON
```

- 10 Use [◀] or [▶] to select the setting you want.
 - Select:
 - <AUTO PRINT ON> to turn on automatic printing of the ACTIVITY REPORT.
 - <AUTO PRINT OFF> to turn off automatic printing of the ACTIVITY REPORT.
- 11 Press [Set].
- 12 Press [Stop/Reset].

► Adjusting the TX REPORT setting

Your machine can print a TX (transmission) report after sending a document. You can set it to print every time it sends a document, or only when an error occurs. Alternatively, you can disable printing of a report.

Follow this procedure to adjust this setting:

- 1 Press [Menu].
- 2 Use [◀] or [▶] to select <USER DATA>.
- 3 Press [Set].

```
USER DATA
1.TEL REGISTRATION
```

- 4 Use [◀] or [▶] to select <FAX SETTINGS>.
- 5 Press [Set].

```
FAX SETTINGS
1.USER SETTINGS
```

- 6 Use [◀] or [▶] to select <REPORT SETTINGS>.
- 7 Press [Set] twice.

```
TX REPORT
PRINT ERROR ONLY
```

- 8 Use [◀] or [▶] to select the setting you want.
 - Select:
 - <PRINT ERROR ONLY> to print a report only when a transmission error occurs.
 - <OUTPUT YES> to print a report every time you send a document.
 - <OUTPUT NO> to disable printing of a report.

● If you selected <OUTPUT NO> in step 8:

- 9 Press [Set].
- 10 Press [Stop/Reset].

● If you selected <PRINT ERROR ONLY> or <OUTPUT YES> in step 8:

- 9 Press [Set].

```
PRINT WITH IMAGE
ON
```

- 10 Use [◀] or [▶] to select if you want the first page of your fax to be printed under the report (valid for black & white faxes only).
 - Select:
 - <ON> to print the first page of the fax under the report.
 - <OFF> not to print the first page of the fax under the report.

- 11 Press [Set].
- 12 Press [Stop/Reset].

► Adjusting the RX REPORT setting

Your machine can print an RX (reception) report after receiving a document. You can set it to print every time it receives a document, or only when an error occurs. Alternatively, you can disable printing of a report.

Follow this procedure to adjust this setting:

- 1 Press [Menu].
- 2 Use [◀] or [▶] to select <USER DATA>.
- 3 Press [Set].

```
USER DATA
1.TEL REGISTRATION
```

- 4 Use [◀] or [▶] to select <FAX SETTINGS>.
- 5 Press [Set].

```
FAX SETTINGS
1.USER SETTINGS
```

- 6 Use [◀] or [▶] to select <REPORT SETTINGS>.
- 7 Press [Set].

```
REPORT SETTINGS
1.TX REPORT
```

- 8 Use [◀] or [▶] to select <RX REPORT>.
- 9 Press [Set].

```
RX REPORT
OUTPUT NO
```

- 10 Use [◀] or [▶] to select the setting you want.
 - Select:
 - <OUTPUT NO> to disable printing of a report.
 - <PRINT ERROR ONLY> to print a report only when a reception error occurs.
 - <OUTPUT YES> to print a report every time you receive a document.
- 11 Press [Set].
- 12 Press [Stop/Reset].

► Printing the USER'S DATA LIST

The USER'S DATA LIST allows you to check the current settings of your machine as well as the registered sender information (→ p. 6-2).

Follow this procedure to print the USER'S DATA LIST:

- 1 Press [Fax].**
- 2 Press [Menu].**
- 3 Use [◀] or [▶] to select <REPORTS/LISTS>.**
- 4 Press [Set].**

```
REPORTS/LISTS
1.ACTIVITY REPORT
```

- 5 Use [◀] or [▶] to select <USER DATA LIST>.**
- 6 Press [Set].**

► Replacing ink tanks

When to replace an ink tank

If one of the following messages appears in the LCD, replace the necessary ink tank(s) as described on p. 11-2:

<C INK EMPTY>Cyan ink tank empty
 <M INK EMPTY>Magenta ink tank empty
 <Y INK EMPTY>Yellow ink tank empty
 <Bk INK EMPTY>Black ink tank empty

If more than one ink tank is empty, several letters may appear (e.g. <C Y INK EMPTY>).

If no message appears but print quality is below standard, refer to the flow chart to determine the problem (→ p. 11-3).

Guidelines

▲ CAUTION

- **Keep the printhead and ink tanks out of the reach of children. If a child inadvertently ingests ink, consult a physician immediately.**
- **Damage caused by using refilled ink tanks is not covered by Canon's warranty. To ensure optimum printing results and to avoid printing problems, Canon recommends using original Canon ink tank only.**
- Ink tanks compatible with the machine are as follows:
 - Black ink tank: BCI-3eBK – Cyan ink tank: BCI-3eC
 - Magenta ink tank: BCI-3eM – Yellow ink tank: BCI-3eY
- Replaced ink tanks should be new. If you install partially used ink tanks, the nozzles may block and the ink tank replacement warning may not be accurate.
- For best ink quality, use ink tanks within one year of purchase. After placing ink tanks in the machine, use the ink tanks within six months.
- Do not open the ink tank packaging until ready to install.
- Do not touch printed paper with wet hands or spill liquids on it as the ink may run.
- Replace ink tanks quickly and do not leave them out in the open. Doing so may cause the ink tank not to function properly when reinstalled in the machine.

Replacing an ink tank

This section describes how to replace an ink tank. Before replacing an ink tank, be sure to read the section *When to replace an ink tank* (→ p. 11-1).

⚠ CAUTION

- Do not replace ink tanks while the machine is printing or performing another operation.

Follow this procedure to replace an ink tank:

- 1 Make sure the power is turned on.
- 2 Press [Open] ① and lift up the scanning unit ②.

- The printhead holder automatically moves to the center of the machine.

⚠ CAUTION

- Do not try to manually move or stop the printhead holder.
- Do not touch any metal parts.

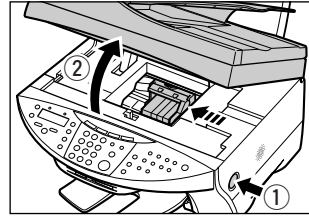

- 3 Press on the tab to release the empty ink tank ①, then remove it from its slot ②.

⚠ CAUTION

- Do not remove the printhead from the machine.
- If several ink tanks need replacing, remove and replace each one individually.

📢 IMPORTANT

- Discard the empty ink tank immediately according to local laws and regulations for disposal of consumables.
- Handle ink tanks carefully to avoid staining clothing or the surrounding area.

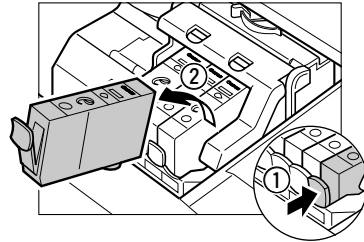

- 4 On the new ink tank, pull the orange tape in the direction of the arrow and remove the plastic wrapper so you can see the air hole ①. Turn the ink tank over so that the protective cap ② is facing up. Then hold the ink tank as shown and remove the protective cap ②.

- To avoid spilling ink, never press on the long sides of the ink tank ③.
- Once you remove the cap ②, do not touch the ink port ④.

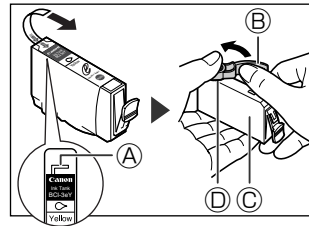

- 5 Insert the ink tank into the empty slot on the printhead. Press down gently on the ink tank until an audible click is heard.

- Make sure the ink tank is the correct color for the slot.

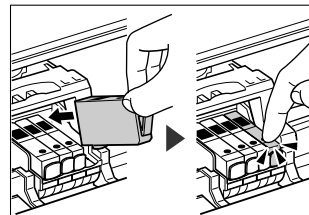

- 6 Close the scanning unit until it locks into place.

► Maintaining the printhead

NOTE

- Before doing the following, open the scanning unit, press "PUSH" on the ink tanks and check that they are securely inserted. Check how much ink is left and if there is none, replace the ink tank (→ p. 11-1).

Flowchart of printhead maintenance

If print quality deteriorates, follow this procedure:

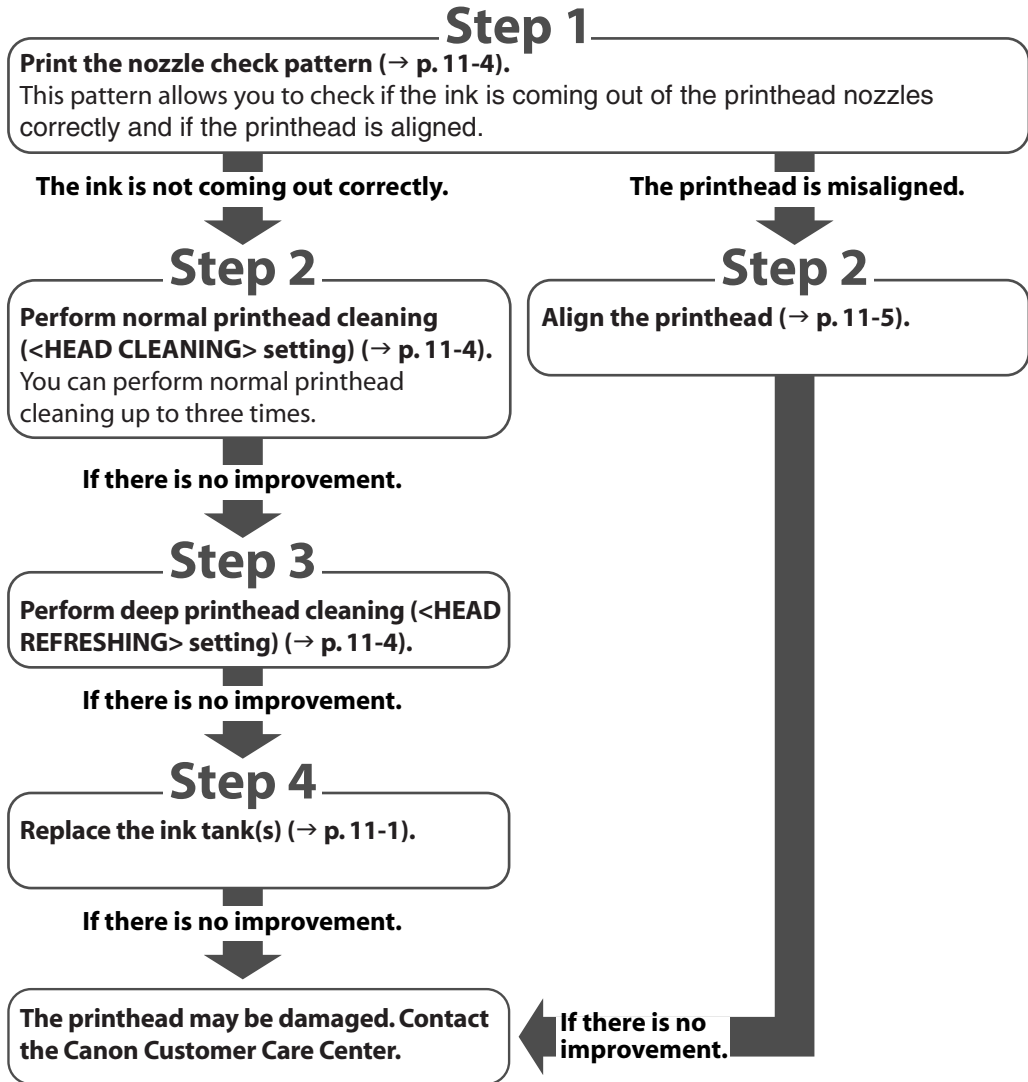

Printing the nozzle check pattern

The nozzle check pattern shows if each printhead nozzle is operating properly.

NOTE

- You can also print the nozzle check pattern from your computer (→ *Software Guide*).

Follow this procedure to print the nozzle check pattern from the machine:

- 1 Load letter-size plain paper in the multi-purpose tray.**
- 2 Press [Menu].**
- 3 Use [◀] or [▶] to select <MAINTENANCE>.**
- 4 Press [Set] twice.**

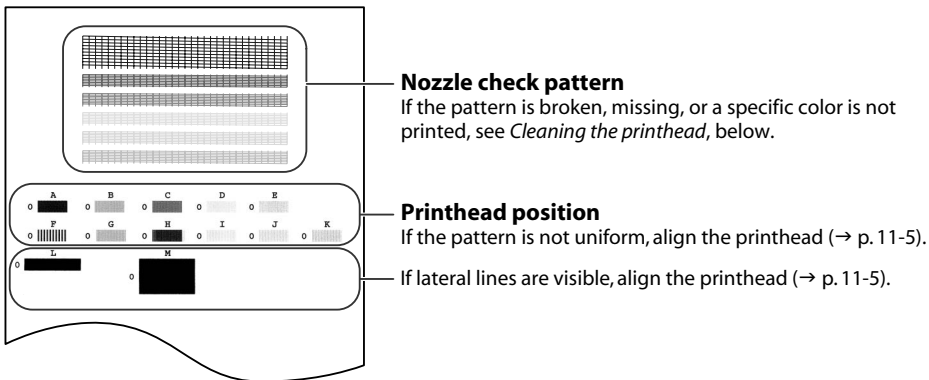

Cleaning the printhead

If the printed nozzle check pattern is broken, missing, or a specific color is not printed, clean the printhead.

NOTE

- Cleaning the printhead consumes a small amount of ink. Cleaning too often reduces the amount of ink in the ink tanks.
- You can also clean the printhead from your computer (→ *Software Guide*).

Follow this procedure to clean the printhead from the machine:

- 1 Press [Menu].**
- 2 Use [◀] or [▶] to select <MAINTENANCE>.**
- 3 Press [Set].**

```
MAINTENANCE
1.NOZZLE CHECK
```

- 4 Use [◀] or [▶] to select the cleaning setting you want.**
 - Select:
 - <HEAD CLEANING> for normal printhead cleaning.
 - <HEAD REFRESHING> for deep printhead cleaning.
 - For details on which to select, see p. 11-3.

- 5 Press [Set].**

Aligning the printhead

To align the printhead after you have just installed it, follow the procedure in the Set-Up Sheet. If you have printed the nozzle check pattern (→ p. 11-4) and determined that the printhead needs aligning, align it from the operation panel (→ below) or from the software (→ *Software Guide*).

Follow this procedure to align the printhead from the operation panel:

- 1 Load letter-size plain paper in the multi-purpose tray.**
- 2 Press [Menu].**
- 3 Use [◀] or [▶] to select <MAINTENANCE>.**
- 4 Press [Set].**



- 5 Use [◀] or [▶] to select <ALIGN PRINT HEAD>.**
- 6 Press [Set].**

• The machine prints a horizontal pattern.



- 7 In column A on the printout, note which box has the most solid image. Note the value next to this box and use [◀] or [▶] to enter it.**



- 8 Press [Set].**
- 9 Repeat steps 7 and 8 for columns B to K. When all values have been entered, the LCD displays the following:**



- 10 Press [✳].**

- 11** When the horizontal pattern has been adjusted, the machine will print a vertical pattern.
- 12** In column L on the printout, note which box has the most solid image. Note the value next to this box and use [◀] or [▶] to enter it.

CHANGE V VALUE
L 0

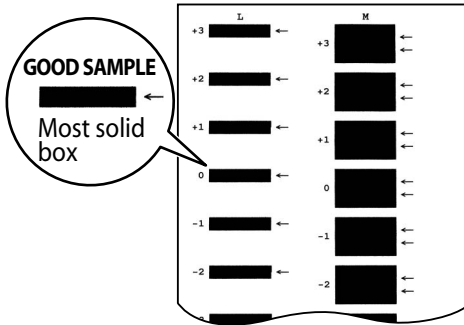

- 13** Press [Set].
- 14** Repeat steps 12 and 13 for column M.

► Cleaning your machine

This section describes the necessary cleaning procedures for your machine.

▲ CAUTION

- Be sure to turn off the power and disconnect the power cord before cleaning the machine.
- **Fax Model** Print any documents stored in memory before disconnecting the power cord, since documents in memory are erased when the power is disconnected (→ p. 8-8).
- Do not use tissue paper, paper towels, or similar materials for cleaning; they can stick to the components or generate static charges. Use a soft cloth to avoid scratching the components.
- Never use volatile liquids such as thinners, benzene, acetone, or any other chemical cleaner to clean the interior of the machine; these can damage the machine's components.

Cleaning the exterior

Wipe the machine's exterior with a clean, soft, lint-free cloth moistened with water or diluted dishwashing liquid.

Cleaning the interior

Cleaning the scanning area

Wipe the platen glass (A), white area (B), and **Fax Model** transparent sheet (C) with a clean, soft, lint-free cloth moistened with water. Then wipe with a clean, soft, dry, lint-free cloth making sure there are no residues left, especially on the platen glass.

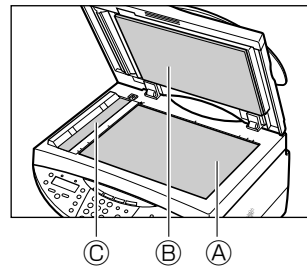

Cleaning inside the machine

To prevent ink spots and paper dust from accumulating inside the machine and affecting print quality, clean the machine's print area periodically.

Follow this procedure to clean inside the machine:

- 1 Turn off the power and disconnect the power cord from the wall outlet.
- 2 Press [Open] (1) and lift up the scanning unit (2).

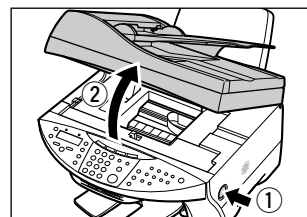

▲ CAUTION

- Do not touch the round shaft (A), transparent film (B), film cable (C), ink absorber (sponge part) (D), or any metal parts.

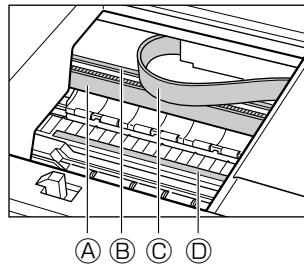

- 3 Use a dry cloth to wipe away any stray drops of ink, scraps of paper, and dust, especially from the black panel (E).

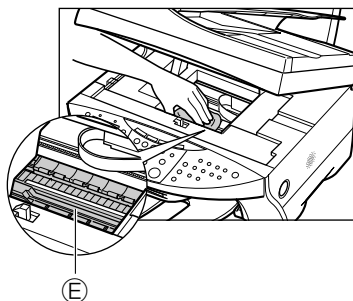

- 4 Close the scanning unit until it locks into place.
- 5 Reconnect the power cord and turn on the power.

Fax Model **Cleaning the ADF area**

Follow this procedure to clean the ADF area:

- 1 Turn off the power and disconnect the power cord from the wall outlet.
- 2 Open the feeder cover.

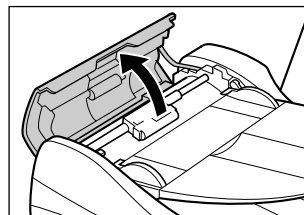

- 3 Use a clean, soft, dry, lint-free cloth to wipe up paper dust from the shaded area.

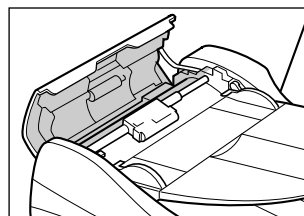

- 4** When you are finished, close the feeder cover until it clicks.
- 5** Reconnect the power cord and turn on the power.

Cleaning the roller

Clean the roller when envelopes do not feed correctly.

Follow this procedure to perform roller cleaning:

- 1** Remove any print media from the multi-purpose tray.
- 2** Press [Menu].
- 3** Use [◀] or [▶] to select <MAINTENANCE>.
- 4** Press [Set].



MAINTENANCE
1. NOZZLE CHECK

- 5** Use [◀] or [▶] to select <ROLLER CLEANING>.
- 6** Press [Set].
- 7** When cleaning has finished, repeat this procedure twice more. Then load letter-size plain paper and repeat this procedure a further three times from step 2.

Troubleshooting

▶ Problems installing and removing software

See below if you were unable to install or remove the software.

[MP Drivers/MP Toolbox]

● Cannot install the software.

1. Have you followed the instructions in the Set-Up Sheet to install the software?

If you have not followed the installation procedure correctly, try reinstalling the software. If there was an error during installation and installation was not completed, restart your computer and try reinstalling the software.

2. Are any other applications open?

If you have other applications open, quit all of these and try reinstalling the software.

3. Have you installed an earlier version of the software (version 4.4 or earlier)? (Is Canon MultiPASS registered as the startup item in the Start menu program?)

Remove the old version of the software following the instructions in the Software Guide of that version and try reinstalling the new version.

[MP Toolbox only]

● Installation or removal of the MP Toolbox cannot be completed.

1. To prepare for forced re-installation, on the Windows desktop, double-click [My Computer]. Open the CD-ROM icon, then double-click [\MP\English\Toolbox\Setup\FrcInst.exe].

2. Return to a folder a level above, then double-click [\MP\English\Toolbox\Setup.exe] to re-install (→ *Software Guide*).

[MP Drivers only]

● Removal of the MP drivers takes too long (Windows XP).

Removal of the software will take longer if an application such as a virus checker is running. Quit any applications (including virus checkers) before removing the software.

● Removal of the software was completed, but [Canon] remains.

When removing the software, if you remove the MP drivers before removing the MP Toolbox, [Canon] will remain displayed in [(All) Programs]. To remove [Canon], in the Start menu, open [Taskbar and Start Menu Properties] and remove it from here.

● The message <Version conflict> appears on your computer (Windows 98).

If the message <Version conflict> or <Windows 98 file language or ...> appears during installation, click [Yes] or [No]. Whichever you click, installation thereafter will continue trouble-free.

This message will appear if you have Photoshop installed on your computer.

- **Cannot use the software after upgrading to Windows XP.**

If the software was installed in Windows 98/Me/2000 and you upgraded to Windows XP without removing the software, the machine may not be able to be recognized. Remove the software and then reinstall it (→ *Software Guide*).

- **In [Device Manager], green mark “?” is displayed (Windows Me).**

Under [Device Manager], green mark “?” is displayed on [USB Composite Device] in [USB (Universal Serial Bus) Controller] in Windows Me. However, this is not a problem so continue to use it as is.

▶ Problems turning on the computer

See below if you cannot start your computer.

- **Computer will not start.**

- Did you turn on your computer with a memory card inserted in the machine?**

If a memory card is inserted in the machine and the machine is connected to the computer, your computer may not start depending on its settings.

In the computer's BIOS settings, if you set up the order so that the hard disk that starts Windows starts before the USB device, your computer will start even with a memory card inserted in the machine. For details on BIOS settings, refer to your computer's documentation.

▶ Problems printing from your computer

See below if you have tried unsuccessfully to print from your computer, or if you cannot print images scanned to your computer.

The  mark indicates problems that also occur when printing copies or receiving faxes on your machine.

- **Cannot print at all.**

-  **1. Is there anything displayed in the LCD?**

If nothing is displayed, see p. 12-14.

-  **2. Is the Alarm light blinking?**

If it is blinking, see p. 12-18.

- 3. Is the background of the BJ Status Monitor picture yellow or red?**

Follow the instructions in the BJ Status Monitor (→ *Software Guide*).

- If <Service error 5100> appears.**

Remove the paper jam or whatever is preventing the printhead holder from moving (→ p. 12-15).

If the message remains, press [ON/OFF (1 sec.)] to turn the machine off, then press again to turn it on.

-  **4. Are the ink tanks installed correctly?**

Press [Open] and lift up the scanning unit (printer cover). Press “PUSH” on the ink tanks and check that they are securely inserted. Also, check that the ink tanks are inserted in the correct slots (→ p. 11-2).

-  **5. Print the nozzle check pattern (→ *Maintaining the printhead*, p. 11-3).**

- 6. Are you trying to print in DOS?**

You can only print in Windows and not in DOS.

7. Is there an application error or General Protection Fault error displayed on the computer? Is the application you are using to print with compatible with the operating system?

Refer to the application's documentation. If the application is not compatible, generally you will be unable to print.

Has the application been allocated enough memory?

If other applications are open, close them to increase the available memory.

Refer to the application's documentation to check the amount of memory the application requires.

If a problem occurs when printing a specific document.

Try printing again after opening and editing the document.

8. Does the hard disk have enough available space?

If not, delete files you do not need to increase the available disk space.

9. Restart the computer.

10. There may be a problem with the printer driver.

Remove the printer driver and try reinstalling (→ *Software Guide*).

● **Cannot print to a shared printer.**

1. Is the server (the computer to which the machine is connected) turned on?

Turn the server on.

2. Is the server set up for printer sharing?

Set up the server for printer sharing (→ *Software Guide*).

3. Is the server set up to allow your system access to the shared printer?

Set up the server to allow your system access to the shared printer.

● **Printing stops in the middle.**

 **1. Has the machine been printing continuously over a long period?**

If so, the printhead will overheat. To protect the printhead, printing will stop temporarily and resume after a period of time. Interrupt printing when appropriate, turn off the machine and wait 15 minutes.

▲ CAUTION

• **The area around the printhead may become extremely hot. Do not under any circumstances touch it.**

 **2. Are you printing large files such as photographs or illustrations?**

If you are printing large files, it will take time to process the data and printing will appear to have stopped. Wait until data is processed.

* If you are printing a document with a large printing area or are printing more than two pages, printing may stop to allow the ink time to dry.

● **Paper does not feed properly.**

 **1. Is the paper the correct weight?**

Use 17–28 lb. (64–105 g/m²) paper.

 **2. Does the paper stack exceed the paper limit mark (▶) or tab, or exceed the capacity of the multi-purpose tray?**

If so, reduce the amount of paper.

 **3. Has the paper been loaded correctly?**

Check that the paper has been loaded correctly and that the paper guide is properly adjusted (→ *Set-Up Sheet*).

 **4. Is the paper creased or curled?**

You cannot use paper that is creased. Uncurl curled paper.

 **5. Clean the roller (→ p. 11-9).**

 **6. Is there some foreign matter in the multi-purpose tray?**

Check and remove any foreign matter.

● Paper curls.

🔧 1. Remove the printed page after 30 to 60 seconds.

The paper may curl if you use thin paper and print images that use a large quantity of ink such as photographs or pictures.

Leave the printed page in the paper output tray for 30 to 60 seconds and remove when the ink has dried.

2. Is intensity set too high?

The paper may curl or rub if intensity is set too high in the printer driver. In the [Properties] dialog box, on the Main tab, click [Manual] in Color Adjustment, then click [Set]. In the [Manual Color Adjustment] dialog box, reduce the intensity with the Intensity slider.

🔧 3. Are you using thin paper?

The paper may curl if you use thin paper and print images that use a large quantity of ink such as photographs or pictures with intense colors. Use thicker paper such as high resolution paper or glossy photo paper (→ p. 3-2).

🔧 4. Was the paper already curled before loading?

Uncurl the paper and reload.

● Meaningless characters and symbols are printing.

If this problem only occurs when printing a specific document.

Open and edit the document and try printing again. If this does not work, there may be a problem with the application. Contact the application's manufacturer.

● White streaks appear on the printout.

🔧 1. Print the nozzle check pattern (→ *Maintaining the printhead*, p. 11-3).

2. Are you printing on coated paper?

In the [Properties] dialog box, on the Main tab, click [High] in Print Quality.

● Printout is rubbed or stained.

🔧 1. Is the paper thickness lever set correctly?

When you print documents that contain large quantities of ink such as documents with a lot of detail, the paper may curl and rub. Move the paper thickness lever to the right (→ p. 3-5).

🔧 2. Does the paper stack exceed the paper limit mark (▶) or tab, or exceed the capacity of the multi-purpose tray?

If so, reduce the amount of paper.

3. Are you printing outside the printable area?

Change the margin settings in the application to keep the document within the recommended printable area.

4. Is intensity set too high?

The paper may curl or rub if intensity is set too high in the printer driver.

In the [Properties] dialog box, on the Main tab, click [Manual] in Color Adjustment, then click [Set]. In the [Manual Color Adjustment] dialog box, reduce the intensity with the Intensity slider.

🔧 5. Are you using recommended print media?

For recommended print media, see p. 3-1.

🔧 6. Clean the machine's interior.

If the machine's interior is dirty with ink or there is a build-up of paper dust, your printout may contain ink stains. Clean the machine (→ p. 11-7).

🔧 7. Are you printing on the wrong side of the paper?

Some papers have a right side for printing. Turn the paper over and try printing again. There are also types of paper such as Photo Paper Pro that can only be printed on one side.

● **The ink empty message is displayed differently on the printer status monitor than how it is displayed on the machine's LCD.**

While you are printing from your computer, if the ink empty message is displayed on the printer status monitor and on the machine's LCD, press [Resume] on the machine and cancel the job. On the printer status monitor, the message changes to [Ink low] and you can continue printing for a short period of time.

However, the ink empty message on the machine's LCD does not change so replace the appropriate ink tank.

▶ Copying problems

See below if you are having problems copying.

For printing-related problems, see the items marked with  in *Problems printing from your computer*, p. 12-2.

● **Cannot make a copy (the document or paper will not feed into the machine).**

1. **Is there anything displayed in the LCD?**

If nothing is displayed, see p. 12-14.

2. **Is the Alarm light blinking?**

If it is blinking, see p. 12-18.

3. **Is the document loaded correctly?**

Check that the document is loaded correctly on the platen glass or  ADF (→ p. 2-2).

4. **See *Paper does not feed properly* on p. 12-3.**

5. **Are the ink tanks installed correctly?**

Press [Open] and lift up the scanning unit (Printer cover). Press "PUSH" on the tanks and check that they are securely inserted.

6. **Print the nozzle check pattern (→ *Maintaining the printhead*, p. 11-3).**

● **Paper comes out but there is nothing copied on it.**

1. **Is the document loaded correctly?**

If placing the document on the platen glass, the side to be copied should be face down.  If placing the document in the ADF, the side to be copied should be face up (→ p. 2-2).

2. **Has ink run out?**

If nothing prints or one of the colors does not print, check if the ink tanks are empty. Replace the ink tank(s) if necessary. Also, make sure the orange tape has been completely removed from the ink tanks.

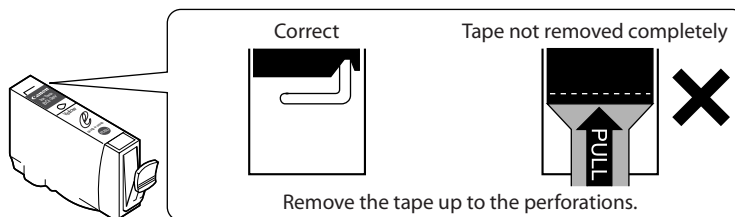

3. **Print the nozzle check pattern (→ *Maintaining the printhead*, p. 11-3).**

● Copy quality is poor (or documents are printed with streaks).

1. Are you copying a document or photograph printed from your machine?

Image quality may be poor when you copy a document or photograph printed from your machine. Try printing the photograph from the memory card, or the document from your computer.

2. Clean the scanning area (→ p. 11-7) and the **Fax Model** ADF area (→ p. 11-8).

3. Clean the printhead (→ p. 11-4).

4. Does the LCD show the correct type of print media loaded?

If not, set the print media type (→ p. 3-6).

5. Is the image quality displayed in the LCD suitable for the document?

If not, set an image quality suitable for the document (→ p. 5-2).

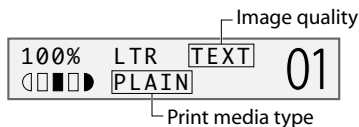

► Problems scanning

See below if you have problems scanning a document to your computer from the machine.

● Cannot scan a document.

1. Is there anything displayed in the LCD?

If nothing is displayed, see p. 12-14.

2. Is the Alarm light blinking?

If it is blinking, see p. 12-18.

3. Is the document loaded correctly?

Check that the document is loaded correctly on the platen glass or **Fax Model** ADF (→ p. 2-2).

4. Restart the computer.

5. If using a USB hub or repeater, try connecting the USB cable directly to the computer.

If you can scan documents successfully after connecting the USB cable directly to the computer, the USB hub or repeater may be broken. Replace if necessary.

6. Are you using a USB 2.0-compatible USB hub?

If you are connecting a USB 2.0-equipped computer and the printer using a USB 2.0-compatible USB hub, you may not be able to scan. In this case, connect the USB cable directly to the computer.

If you want to connect the printer and computer via a USB 2.0-compatible hub, follow the steps below to modify the INI file. It is recommended that before opening the file in step 1 below, you make a backup copy of the file in another folder before making any changes to it.

1. Open the following file in Notepad or another text editor application.

Windows 98/Me:

windows\system\CNCMP50.ini

Windows 2000:

winnt\system32\CNCMP50.ini

Windows XP:

windows\system32\CNCMP50.ini

2. Below the last line, add the following two lines, then save the file. Take care not to modify any other parts.

```
[Scan]
```

```
ReadSize=16
```

7. **Fax Model** Is the [Select source] setting in the MP Toolbox, ScanGear MP, or WIA driver set correctly?

Choose between loading the document on the platen glass or ADF.

8. After installing the software, did you install a TWAIN-compatible application?

If this is the case, the TWAIN system file is replaced with something inappropriate and you will be unable to scan images. If this happens, remove the software (→ *Software Guide*) and reinstall (→ *Set-Up Sheet*).

9. Is the machine recognized in the [Scanners and Cameras] window of [Control Panel] ?

Follow this procedure to check if the machine icon is present in [Scanners and Cameras] of the [Control Panel]:

1. On the Windows desktop, click [Start], point to [Settings], then click [Control Panel]. (Windows XP: On the desktop, click [Start], then [Control Panel].)
2. Double click [Scanners and Cameras]. (Windows XP: In the [Control Panel] window, click [Printers and Other Hardware], then [Scanners and Cameras].)
3. In the [Scanners and Cameras] window, if [Canon MP730] or [Canon MP700] (Windows XP: [WIA Canon MP730] or [WIA Canon MP700]) is present, the machine is recognized. If not, remove the software (→ *Software Guide*) and reinstall (→ *Set-Up Sheet*).

● **You tried to create a multipage PDF, but were not able to scan several documents.**

Click a button on the MP Toolbox and in the settings dialog box, select [Use the scanner driver to make advanced settings]. When ScanGear MP opens, if you scan with the [Automatically quit ScanGear MP after scanning] setting selected in [Preferences] of Advanced Mode, only the documents placed at one time on the platen glass will be scanned. If you want to scan additional documents, clear the [Automatically quit ScanGear MP after scanning] setting before scanning.

● **Computer has hung up or frozen.**

1. Quit other open applications and try again.

Memory may be insufficient. Quit other open applications and try again.

2. Does the hard disk have enough available space?

Check that the hard disk has enough available space, in particular when scanning large documents at a high resolution. For example, a letter-size document scanned at 600 dpi, full color requires a minimum of 300 MB of space.

* If you do not have enough available space, scan the document at a lower resolution.

3. If an error occurs when scanning an image in Photoshop.

Change the allocated memory. On the Edit menu, point to [References], then click [Memory & Image Cache]. Change the Physical Memory Usage to 10% or 20%.

4. Remove the software (→ *Software Guide*) and reinstall (→ *Set-Up Sheet*).

● **You installed the applications on the MultiPASS MP730/700 Setup CD-ROM but they were not registered in the MP Toolbox.**

If you install the applications with the MP Toolbox open, the applications will not be registered in the MP Toolbox. Click [Defaults] to register them (→ *Software Guide*).

● **When you click a key on the MP Toolbox, another application opens.**

When you click a key on the MP Toolbox, you may want another application to open.

Click a key on the MP Toolbox and select the application you want to open for that key. Repeat for the other keys (→ *Software Guide*).

● **You opened the [Preferences] dialog box from the [Scanners and Cameras] icon and changed the settings, but the settings were not activated (Windows 2000).**

In Windows 2000, if you open [Scanners and Cameras] in [Control Panel] and change the settings in [Events], the settings will not be activated unless you restart your computer. Once you have changed your settings, restart your computer.

● **Fax Model You canceled a scan before completion and the document became jammed in the ADF.**

Press [Resume] to eject the document from the ADF (→ *Software Guide*).

● **The image you have scanned looks dirty (or documents are printed with streaks).**

1. **If the image looks grainy, increase the scan resolution (→ *Software Guide*).**
2. **Display the image at 100%.**
Some applications do not display an image well at small sizes. Try displaying the image at 100% magnification.
3. **There is more when you scan printed material.**
In ScanGear MP, click [Descreen] (→ *Software Guide*).
4. **Set the monitor display colors to 16-bit or higher.**
In [Display Properties], set the display colors to 16-bit color, 24-bit color or higher.
5. **Clean the platen glass and document cover (→ p. 11-7).**

● **White margins appear around the scanned image.**

Specify the scan area.

In ScanGear MP, click [Multi-Scan] to automatically specify the scan area.

If there are white margins around documents such as photographs, or if you want to trim a document (i.e. you want to scan only one part of a document), specify the area of the scan manually (→ *Software Guide*). To display ScanGear MP when scanning, click a button on the MP Toolbox and select [Use the scanner driver to make advanced settings]. Clear this setting if you do not want ScanGear MP to display (→ *Software Guide*).

● **White lines appear on the left side of the image.**

Place the document approximately $\frac{1}{8}$ inch (3 mm) from the edge of the platen glass.

● **Cannot scan correctly with multi-scan.**

1. **Does the position of the photographs and the way they are positioned fulfill the following requirements?**
 - There should be a gap of at least $\frac{3}{8}$ inch (1 cm) between the edge of the platen glass and photographs.
 - There should be a gap of at least $\frac{3}{8}$ inch (1 cm) between the edges of the photographs.
 - There should be no more than ten photographs.
 - The photographs should be straight (any tilting should be kept within 10 degrees).
2. **Some applications do not accept multiple scans of more than two images.**
Check the application's documentation or contact the application's manufacturer.
3. **Clean the platen glass and document cover (→ p. 11-7).**
4. **When scanning from the platen glass, thick or curled photographs may not be scanned properly.**
Press lightly on the document cover when scanning.
5. **Is the document smaller than $\frac{9}{64}$ inch² (1 cm²)?**
You cannot use multi-scan for documents smaller than $\frac{3}{8}$ inch \times $\frac{3}{8}$ inch (1 cm \times 1 cm). Scan each document separately.
6. **Is the ratio of the long and short sides of the document greater than 1:4?**
You cannot use multi-scan if the long side of the document is 4 or more times longer than the short side. Scan each document separately.

● **Scanned image is displayed at a large (small) size on the computer screen.**

1. **Enlarge or reduce the image display in the application.**
However, if you open the image in Paint or Imaging, it may display at a large size and you will not be able to reduce it.
2. **Change the resolution and scan again.**
The image will be large if resolution is high. It will be small if resolution is low (→ *Software Guide*).

See below if you are having problems receiving faxes.

● **Cannot receive a fax, cannot print a fax.**

1. Is there anything displayed in the LCD?

If nothing is displayed, see p. 12-14.

2. Is the Alarm light blinking?

If it is blinking, see p. 12-18.

3. Is the machine making a noise and is the In Use/Memory light blinking?

A telephone (or other peripheral device such as an answering machine or computer modem) is connected to the ☐ jack. Reconnect to the ☒ jack (→ *Set-Up Sheet*).

4. Nothing is printed on the printout.

Print the nozzle check pattern (→ p. 11-4).

If the nozzle check pattern does not print properly, see p. 11-3.

If the nozzle check pattern does print properly, see the items marked with 📄 in *Problems printing from your computer*, p. 12-2.

NOTE

• Once printed, received faxes are automatically deleted from the machine's memory. Accordingly make sure the printhead is cleaned periodically (→ p. 11-4) to avoid clogging and potential loss of data.

5. In manual receive mode, did you pick up the handset to receive a fax and before replacing the handset, did you press [Start] or dial the remote receiving ID number?

If you replace the handset without doing either of these things, the call will disconnect.

6. Which receive mode is displayed on the bottom left of the LCD? Have you followed the procedure for that receive mode correctly?

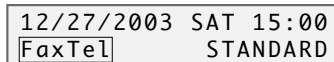

└ Receive mode

<FAX/TEL AUTO SW>: Fax calls are received automatically and the telephone rings for voice calls. There are no procedures to follow for receiving faxes. Ringing indicates a voice call so pick up the handset. *A phone connected to your machine will not ring.

<FAX ONLY MODE>: The machine automatically receives faxes without ringing. You cannot manually answer calls.

<DRPD>: Set this mode if you have subscribed to a DRP (Distinctive Ring Pattern) service offered by some companies. The machine will then ring differently depending on whether a call is a fax or voice call.

<MANUAL MODE>: The machine rings for both voice and fax calls. If you hear the machine ring, pick up the handset and either press [Start] or dial the remote receiving ID to receive a fax.

<ANS.MACHINE MODE>: Fax calls are received automatically and voice calls are received by the answering machine connected to the machine. There are no procedures to follow for receiving faxes. The answering machine should be left connected.

7. Are there documents in the machine's memory?

The memory may be full. Either print or delete documents (→ p. 8-8) to free up memory. Then ask the sender to resend the fax.

8. Was there an error during reception?

Check the LCD for an error message (→ p. 12-19).

Print the ACTIVITY REPORT and check for an error (→ p. 10-2).

9. Is there a telephone line connected?

Check that the telephone line is correctly connected (→ *Set-Up Sheet*).

● Cannot receive faxes automatically.

1. Is <FaxTel>, <FaxOnly>, <DRPD>, or <AnsMode> receive mode displayed on the bottom left of the LCD?

If <Manual> is displayed, you cannot receive faxes unless you pick up the handset and either press [Start] or dial the remote receiving ID.

If you want to receive faxes automatically which means not having to do anything when you are sent a fax, set the receive mode to <FAX/TEL AUTO SW>, <FAX ONLY MODE>, <DRPD>, or <ANS.MACHINE MODE> (→ p. 9-1).

If set to <ANS.MACHINE MODE>, connect an answering machine to the machine (→ *Set-Up Sheet*) and check that a message plays when the answering machine answers.

● Machine does not switch automatically between voice and fax reception.

1. Is <FaxTel>, <DRPD>, or <AnsMode> receive mode displayed on the bottom left of the LCD?

There will be no automatic switching between voice and fax calls unless the receive mode is set to <FAX/TEL AUTO SW>, <DRPD>, or <ANS.MACHINE MODE>. If set to <ANS.MACHINE MODE>, connect an answering machine to the machine (→ *Set-Up Sheet*) and check that a message plays when the answering machine answers.

2. Is the sender's fax machine unable to send a CNG signal (the signal which indicates that the call is a fax call)?

Some fax machines are not able to send CNG signals. If so, receive the fax manually (→ p. 9-3).

● Quality of received fax is poor.

1. Are you using recommended print media?

For recommended print media, see p. 3-1.

2. Print the nozzle check pattern (→ *Maintaining the printhead*, p. 11-3).

Print the nozzle check pattern (→ p. 11-4).

If the nozzle check pattern does not print properly, see p. 11-3.

3. Is <ECM RX> set to <OFF>?

Set <ECM RX> to <ON> (→ p. 13-4).

4. The printed fax is poor quality.

See the items marked with  in *Problems printing from your computer*, p. 12-2.

5. Check whether the sender's fax machine is dirty.

The image quality of the fax is mainly determined by the sender's fax machine. Contact the sender and check whether the document cover and platen glass of his fax machine are dirty.

● Cannot receive a fax in ECM mode.

If you receive a fax in ECM mode, "ECM" will show on the ACTIVITY REPORT. If "ECM" is not shown, the fax was not received in ECM mode.

1. Is <ECM RX> set to <OFF>?

Set <ECM RX> to <ON> (→ p. 13-4).

2. Is the sender's fax machine ECM-compatible?

If the sender's fax machine is not ECM-compatible, the fax will be received in standard mode without error correction.

● Repeated errors occur when you receive a fax.

If there is an error, a message will be displayed in the LCD. The ACTIVITY REPORT and RX REPORT will show "NG" and an error code.

1. Reduce the reception start speed (→ <RX START SPEED>, p. 13-5).

If there is a bad line or connection, reducing the reception start speed may correct the error.

2. Check whether the sender's fax machine is operating normally.

Contact the sender and check whether his fax machine is operating normally.

Fax Model Problems sending faxes

See the items marked with **M** (machine) if you are having problems sending a fax from the machine.

See the items marked with **C** (computer) if you are having problems sending a fax from your computer.

● Cannot send a fax.

M C 1. Is the machine making a noise and is the In Use/Memory light blinking?

The telephone line is connected to the  jack. Reconnect to the  jack (→ *Set-Up Sheet*).

M C 2. Did you set the correct line type?

You can still receive faxes even if the telephone line type is not set correctly. If you can receive but cannot send, check the telephone line type setting (→ p. 6-4).

M C 3. Is there anything displayed in the LCD?

If nothing is displayed, see p. 12-14.

M C 4. Is the Alarm light blinking?

If it is blinking, see p. 12-18.

M C 5. Is the telephone line cord connected properly?

Check that the telephone line cord is connected properly (→ *Set-Up Sheet*).

M C 6. Press [Hook] or pick up the handset of the telephone connected to the machine. Can you hear a tone?

If not, there is a problem with the telephone line. Contact your telephone company.

M 7. Is the document loaded correctly?

Check that the document is loaded correctly on the platen glass or ADF (→ p. 2-2).

M 8. Is one-touch or coded speed dialing registered with fax numbers?

If you are using one-touch or coded speed dialing, check that the fax number is correctly registered (→ Chapter 7).

M C 9. Is the number dialed correct?

Check the number and try dialing again.

M C 10. Is the In Use/Memory light blinking? Is the fax recipient shown in the LCD?

Another document is being sent from memory. Wait until the document has finished sending.

M 11. Was there an error during transmission?

Print the ACTIVITY REPORT and check for an error (→ p. 10-2).

M C 12. Is the recipient's fax machine G3-compatible?

Check that the recipient's fax machine is G3-compatible. If not, you will be unable to send faxes.

● Fax sent is dirty (or documents are printed with streaks).

M 1. Is the document loaded correctly?

Check that the document is loaded correctly on the platen glass or ADF (→ p. 2-2).

M 2. Try making a copy.

If you can make a clean copy, it is probably that the recipient's fax machine is the source of the problem. Contact the recipient to confirm.

If you are unable to make a clean copy, clean the machine (→ p. 11-7).

● Cannot send a fax in ECM mode.

If you send a fax in ECM mode, "ECM" will show on the ACTIVITY REPORT. If "ECM" is not shown, the fax was not sent in ECM mode.

M C 1. Is <ECM TX> set to <OFF>?

Set <ECM TX> to <ON> (→ p. 13-4).

2. Is the recipient's fax machine ECM-compatible?

If the recipient's fax machine is not ECM-compatible, the fax will be sent in standard mode without error correction.

● Repeated errors occur when you send a fax.

1. Reduce the transmission start speed (→ <TX START SPEED>, p. 13-4).

If there is a bad line or connection, reducing the transmission start speed may correct the error.

Fax Model **Telephone problems**

See below if you have problems using the telephone.

● Cannot dial.

1. Is there anything displayed in the LCD?

If nothing is displayed, see p. 12-14.

2. Is the Alarm light blinking?

If it is blinking, see p. 12-18.

3. Is the telephone line cord correctly connected?

Check that the telephone line cord is correctly connected (→ *Set-Up Sheet*).

4. Did you set the correct telephone line type?

Make sure the machine is set for the correct telephone line type (→ p. 6-4).

● Telephone disconnects during a call.

This will happen if the power cord is not connected securely to the machine and wall outlet.

Check that the power cord is securely inserted into the machine and wall outlet, and that the power is on (→ *Set-Up Sheet*).

If the machine is connected to a table tap, OA tap or extension cord, make sure they are connected correctly and, if there is a power switch, that it is on.

Problems using a memory card

See below if the memory card is not recognized when inserted into the machine's slot, or if the image data is not being read.

● Memory card is not recognized.

1. Is the memory card securely inserted into the machine's slot?

2. Is the memory card inserted into the correct slot?

For details on which slot to insert the memory card, see p. 4-2.

3. The memory card is not recognized although it is inserted securely into the machine's slot.

Remove and reinsert the memory card as explained on p. 4-2.

4. Are there any images on the memory card?

Check if there is any image data on the memory card using your digital camera or computer.

5. Is the image data valid?

If standby mode is displayed in photo print mode, there are valid images on the memory card. If a message is displayed, see p. 12-19.

6. Try again with another memory card.

1. If you can print without any problems using a different memory card, the first memory card may be damaged. In this case, reformatting the memory card with a digital camera may fix the problem. However, please note that when you reformat the memory card with a digital camera, all the data will be deleted. If you can read the image data on the computer, copy the image data to your computer before reformatting the memory card.

2. If you still have problems with another memory card, it is having difficulty operating with the machine. Try again with a recommended memory card (→ p. 4-1).

- **"?" is printed in the index.**

Yellow "?": The photograph data is large. Printing of this photograph may take a long time when printing in single frame, frame range, or all frame mode.

Red "?": The photograph data is damaged and cannot be printed on your machine.

- **Cannot write to the memory card (write protect error displayed in Windows).**

1. **Is the machine in photo print mode and the <CARD PROTECT> setting set to <ON>?**

Switch to a different mode and set the <CARD PROTECT> setting to <OFF> (→ p. 4-15). Then turn the machine off and on again.

2. **If a delayed write failed error is displayed in Windows 2000. Is the machine in photo print mode and the <CARD PROTECT> setting set to <ON>?**

Switch to a different mode and set the <CARD PROTECT> setting to <OFF> (→ p. 4-15). Then turn the machine off and on again.

If you want to enable card protection, set the <CARD PROTECT> setting to <ON> (→ p. 4-15). Then turn the machine off and on again.

⚠ CAUTION

• **In Windows 2000, if you set the <CARD PROTECT> setting to <ON>, turn the machine off then on again. If you copy data from the hard disk to the memory card and a delayed write failed error occurs, the original file may be lost.**

3. **Have you connected in Windows XP?**

The date and time of access is written in the Windows XP preview, and if <CARD PROTECT> is set to <ON> or photo print mode is selected, a write protect error may be displayed. Turn the machine off then on again.

- **Removable disk does not appear in Windows Explorer.**

This behavior can occur if you map a network drive to the next available drive letter after the local volumes and CD-ROM drives have been assigned drive letters. Do the following if you experience this problem:

1. Assign the network drive to any other drive letters.
2. Restart your computer.

- **The [Unplug/Eject] icon does not appear (Windows 2000).**

In Windows 2000, the [Unplug/Eject] icon does not appear even when you select [Show Unplug/Eject icon in the taskbar] in the [Unsafe Removal of Device] dialog box that is displayed when you turn off the machine or disconnect the USB cable.

You do not need to use the [Unplug/Eject] icon when you turn off the machine or disconnect the USB cable.

- **The machine does not appear in [Hardware devices] in the [Add/Remove Hardware] dialog box (Windows 2000).**

In Windows 2000, the machine does not appear in [Hardware devices] in the [Select Device to Unplug] dialog box in [Add/Remove Hardware] of [Control Panel].

In Windows 2000, the [Unsafe Removal of Device] dialog box will appear when you turn off the machine or disconnect the USB cable, and the message [To safely unplug or eject any of the following devices, first use the Hardware wizard in the Control Panel to stop the device] will appear. There is however no need to unplug a device with [Add/Remove Hardware] when you turn off the machine or disconnect the USB cable.

● **In Windows Explorer, you cannot display [Thumbnails] (Windows 2000).**

In Windows 2000, if you display the contents of a memory card in Windows Explorer, and change the display to [Thumbnails] on the [View] menu, the images may not display and the computer may freeze. This is a problem that occurs with USB card readers in general, and not just with this machine.

If you want to change the display to [Thumbnails] in Windows Explorer, set the <CARD PROTECT> setting to <OFF> (→ p. 4-15). Then turn the machine off and on again.

● **The memory card is recognized as a drive other than [Removable Disk].**

Did you start your computer with a memory card inserted in a card slot?

Depending on your computer, this may occur if you start your computer with a memory card inserted in the machine.

Remove the memory card and restart your computer.

▶ **If nothing displays in the LCD (if there is no power)**

When you connect the power cord to the machine and wall outlet, and press [ON/OFF (1 sec.)], the machine powers up and a message is displayed in the LCD.

While the Alarm light blinks, the machine is initializing and you will not be able to use it. Wait until the Alarm light stops blinking.

If nothing is displayed in the LCD, make the checks in the following order until something is displayed.

1. Is the power cord correctly connected?

Securely connect the power cord to the machine and wall outlet.

2. Have you pressed [ON/OFF (1 sec.)]?

The machine will power up and the LCD will show a message when you connect the power cord and press [ON/OFF (1 sec.)].

3. Check that the wall outlet is working normally.

Connect another electrical appliance to the wall outlet and check whether the wall outlet is working properly.

4. Connect the power cord directly to the wall outlet.

Disconnect the power cord from any table taps, OA taps or extension cords and connect directly to the wall outlet. If the machine powers up when the power cord is connected directly, the table taps, OA taps or extension cords are probably defective and should be replaced.

If they have a power switch, turn it on.

5. Check that the power cord is not defective.

Either replace the power cord with another, or using a tester, check whether the cord is defective.

► **Fax Model** If the power disconnects unexpectedly

User data and speed dialing settings are stored using the internal battery if there is a power failure or if you accidentally disconnect the power cord. However, all documents stored in memory will be deleted.

If the power disconnects, the following will apply:

- You will not be able to send or receive faxes, or make copies.
- If a telephone is connected to the machine, you may be able to receive and/or make voice calls (depending on your telephone).

When power is restored, the MEMORY CLEAR REPORT will be printed automatically listing the documents deleted from memory. Note however that this report will not be printed if the print media size is set to a setting other than <LTR>, <LGL>, or <A4>, or if black ink or paper has run out.

► **Removing jammed paper**

If <CLEAR PAPER JAM> is displayed in the LCD, follow this procedure to clear the paper jam.

Fax Model If a paper jam occurs when receiving a fax, that fax will be stored in memory and printed automatically when you clear the jam and press [Resume].

Removing jams in the paper output tray

Follow this procedure to remove jams from the paper output tray:

- 1 Gently pull any jammed paper out of the paper output tray.**
 - If you cannot see any jammed paper in the paper output tray, remove it from the machine's interior (→ below).
- 2 Press [Resume].**
 - If you are printing from a Windows application, follow the instructions displayed on your computer.

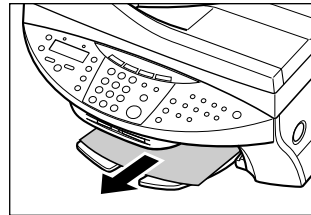

Removing jams from the machine's interior

Follow this procedure to remove jams from the machine's interior:

- 1 Press [Open] ① and lift up the scanning unit ②.**

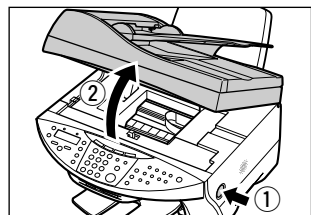

2 Gently gather the jammed paper to the center of the opening and then remove it.

▲ CAUTION

• **Be careful not to touch the components inside the machine.**

- If the jammed paper tears while you are pulling and you cannot remove the torn pieces, turn the machine off then on with the [ON/OFF (1 sec.)] key. The jammed pieces will automatically be ejected.

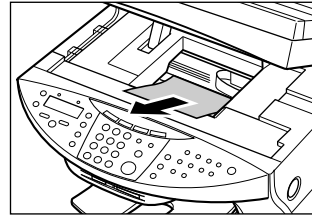

3 Close the scanning unit until it locks into place.

4 Press [Resume].

- If you are printing from a Windows application, follow the instructions displayed on your computer.

If there are repeated paper jams

Paying attention to the following points, reload the paper.

1. Fan out the sheets of paper well so that they do not stick together.
2. Align the edges of the paper.
3. Adjust the paper guide correctly.
4. Make sure the paper stack does not exceed the paper limit mark (▶) or tab.
5. Make sure the paper loaded does not exceed the capacity of the multi-purpose tray (→ p. 2-1).
6. Do not force paper into the multi-purpose tray.
7. Only use the same type of paper.
8. Use recommended print media (→ p. 3-1).

▶ **Fax Model** Removing jammed documents

If documents jam in the ADF or do not feed properly, <DOC. TOO LONG> is displayed in the LCD. You do not need to turn off the power when clearing document jams.

1 Press [Stop/Reset].

2 If a multipage document is loaded, remove from the ADF all pages except for the jammed page.

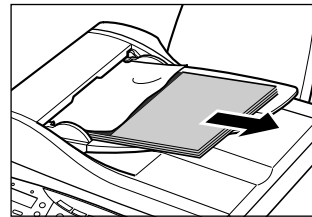

3 Open the feeder cover.

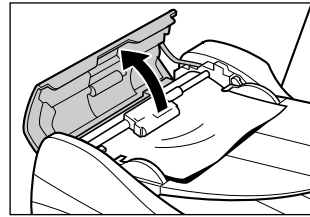

4 Raise the paper release lever **A** and slide the page under the roller towards the feeder cover.

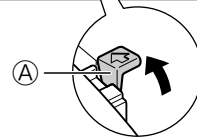
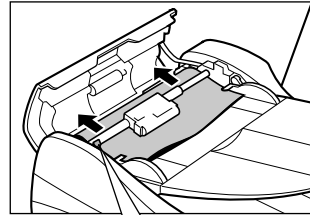

5 Pull out the jammed page from the ADF.

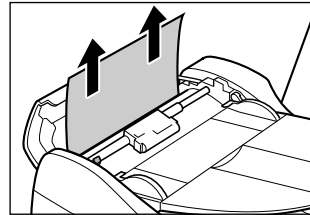

6 Lower the paper release lever **A**, then close the feeder cover.

- If [Stop/Reset] is pressed during scanning and the document remains in the ADF, wait for the machine to return to standby mode, then press [Resume]. Documents left in the ADF will be ejected automatically.

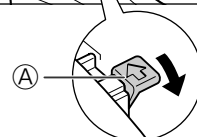
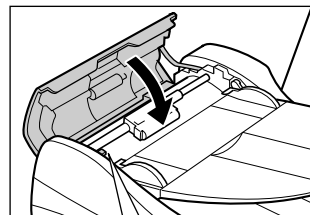

▶ If the nozzle check pattern does not print properly

Refer to *Maintaining the printhead*, p. 11-3.

▶ Interpreting the messages

When the Alarm light blinks

Check the message in the LCD. If there is a message, follow the instructions and correct the error. Then to resume operation, press [Resume]. The Alarm light will turn off.

If the error remains, turn off the machine and disconnect the power cord. Wait 15 seconds, then reconnect the power cord and turn on the power.

If you cannot clear a paper jam

Turn off the machine and disconnect the power cord. Wait five seconds, reconnect the power cord and turn on the power. If the problem has been resolved, the Alarm light will turn off.

If the Alarm light still lights even after you have turned the power on again

Contact the Canon Customer Care Center.

Error codes are printed in the ACTIVITY REPORT.

LCD messages

Message (Error code)	Cause	Action	Details
Fax Model AUTO REDIAL	The machine is waiting to redial the other party's number because the line was busy or the recipient did not answer when you tried to send a document.	Wait for the machine to automatically redial the number. If you want to cancel automatic redialing, wait until the machine starts dialing the number, press [Stop/Reset], then follow the instructions in the LCD.	p. 8-5
Bk INK EMPTY	The black ink tank in the printhead is empty.	Replace the ink tank.	p. 11-2
Fax Model BUSY/NO SIGNAL (#018)	The telephone number you dialed is busy.	Try sending the document at a later time.	
	The fax number dialed was incorrect.	Check the fax number and dial again.	
	The other party's fax machine is not working.	Contact the other party and have them check their fax machine.	
	The other party is not using a G3 machine.	Contact the other party and ask them to send or receive the document using a G3 machine.	
	The touch tone/rotary pulse setting on your machine is incorrect.	Set your machine to the setting that matches your telephone line.	p. 6-4
	The receiving fax machine did not answer within 55 seconds (after all automatic redialing attempts).	Contact the other party and have them check their fax machine. You can try to send the document using manual sending. For an overseas call, add pauses to the registered number.	p. 8-2
C INK EMPTY	The cyan ink tank in the printhead is empty.	Replace the ink tank.	p. 11-2
CANNOT USE THIS CARD TURN OFF AND ON	You have inserted a Microdrive memory card or a damaged card into the card slot.	Remove the memory card from the slot, then turn the power off and on again. You cannot use Microdrive memory cards with this machine.	p. 4-1
CARD READER BUSY	You tried to start photo printing when the memory card slot was in use by the computer.	Wait until the memory card slot is no longer being used by the computer.	
CARTRIDGE JAMMED	The printhead holder cannot move. This is normally due to a paper jam.	Clear the paper jam or whatever is obstructing the printhead holder and then press [Resume]. Do not attempt to move the printhead holder manually.	p. 12-15
Fax Model CHANGE PAPERSIZE:FAX	The print media size setting is set to a size other than <LTR>, <LGL>, or <A4>.	Set the print media size setting to <LTR>, <LGL>, or <A4> and load paper of the same size. The received fax will then be printed automatically.	p. 3-6

Message (Error code)	Cause	Action	Details
Fax Model CHECK DOCUMENT	The feeder cover may not be closed properly.	Close the feeder cover properly.	p. 12-16
	The document is not loaded properly in the ADF, or there may be a document jam.	Remove the document from the ADF and reload it. Clear the document jam if necessary.	p. 2-2 p. 12-16
CHECK PAPER SIZE	The print media size in the multi-purpose tray and that specified in the print media size setting are different.	Load the correct print media size or change the print media size setting. Then press [Resume].	p. 3-7
CHECK PRINTER (PRESS RESUME KEY)	There may be an obstruction that is not allowing the printhead holder mechanism to move.	Check for any obstruction (paper clip, small object, etc.). Check also for a paper jam and clear the jam if necessary. Then press [Resume] and start again. If the message does not clear after pressing [Resume], contact the Canon Customer Care Center.	p. 12-15
	The waste ink tank (which holds the ink used for printhead cleaning) may be full.	Contact the Canon Customer Care Center to have the waste ink tank replaced immediately.	
CLEAR PAPER JAM (PRESS START KEY)	There is a paper jam.	Clear the paper jam and reload paper in the multi-purpose tray. Then press [Start] or [Resume].	p. 12-15
COVER OPEN	You opened the scanning unit during an operation.	Close the scanning unit.	
DATA IN MEMORY CANNOT TURN OFF	You are unable to turn the machine off with the [ON/OFF (1 sec.)] key because there are documents in memory.	Print or delete any documents stored in memory, then turn off the machine.	p. 8-8
Fax Model DOC. TOO LONG (#003)	The document is longer than 3 $\frac{3}{8}$ ft. (1 meter).	Reduce the length of the document to within 3 $\frac{3}{8}$ ft. (1 meter), and then re-send it.	
	There is a document jam in the ADF.	Clear the document jam and reload the document in the ADF.	p. 12-16
Fax Model ECM RX	The machine is receiving a fax using Error Correction Mode (ECM).	ECM receptions may take longer than normal receptions. Turn off ECM if you need to receive quickly, or if you know your local lines are in good condition.	p. 13-4
Fax Model ECM TX	The machine is sending a fax using Error Correction Mode (ECM).	ECM transmissions may take longer than normal transmissions. Turn off ECM if you need to transmit quickly, or if you know your local lines are in good condition.	p. 13-4
FILE NOT READABLE	There are photographs that have been edited on a computer or digital camera.	Check which photographs were not printed and try reprinting them from your computer.	

Message (Error code)	Cause	Action	Details
INSERT PHOTO CARD	There is no memory card in the memory card slot.	If you want to use the photo print function, insert a memory card into the appropriate slot.	p. 4-2
INVALID KEY/SETTING	An invalid key was pressed or an invalid setting was selected.	Check the key or setting you want to enter.	
LOAD PAPER (PRESS START KEY)	The multi-purpose tray is empty.	Load paper in the multi-purpose tray. Make sure the stack is below the paper limit mark (▶) and tab. Then press [Start] or [Resume].	p. 3-7
M INK EMPTY	The magenta ink tank in the printhead is empty.	Replace the ink tank.	p. 11-2
MACHINE IN USE CANNOT TURN OFF	You are unable to turn the machine off with the [ON/OFF (1sec.)] key because the machine is performing an operation.	Wait until the machine has finished, then turn off the machine.	
MEMORY FULL (#037)	The machine's memory is full because you tried to send or copy too many pages at once, or a very long or detailed document.	Divide the document and send or copy each part separately. To free up space in the machine's memory, print or delete any documents in memory you no longer need.	p. 8-8
	In photo print mode, the photograph data is too large to print from your machine.	Print the photograph from your computer.	
	Fax Model The machine's memory is full because it has received too many documents, or a very long or detailed document.	Print any documents stored in memory. Then start again.	p. 8-8
	Fax Model In photo print mode, you tried to print photographs when the machine's memory was full.	Print or delete any documents in memory, or wait for the machine to send any documents stored in memory. Then try printing photographs again.	p. 8-8
Fax Model MEMORY USED nn %	Shows the percentage of memory currently in use.	If you need more space, wait for the machine to send any faxes. Also, print or delete any documents in memory you no longer need.	p. 8-8
NO FILES ON CARD	There are no available files in the memory card.	Make sure you have recorded photographs in the appropriate format on the memory card.	
Fax Model NO RX PAPER (#012)	The other party's fax machine is out of paper or its memory is full.	Contact the other party and have them load paper in their fax machine or free up space in their fax machine's memory.	
Fax Model NO TEL # (#022)	The one-touch speed dialing key or coded speed dialing code you entered has not been registered.	Register the one-touch speed dialing key or coded speed dialing code.	Chapter 7

Message (Error code)	Cause	Action	Details
Fax Model NOT AVAILABLE	In manual sending, you entered a speed dialing number that is assigned to a group.	Use regular dialing, or enter a one-touch speed dialing key or coded speed dialing code that only has one fax/telephone number registered.	Chapter 7
PROBLEM READING CARD REINSERT MEMORY CARD	The data on the memory card may be inaccessible.	Check the data on the memory card in your digital camera.	
PROBLEM READING CARD TURN OFF AND ON	There is a problem with the card slot.	Try switching to another mode or turning the machine off and on. If the message remains, contact the Canon Customer Care Center.	
PUT IN CARTRIDGE	There is no printhead installed in the machine.	Install the printhead.	Set-Up Sheet
Fax Model REC'D IN MEMORY	The machine received the fax in memory because paper or ink ran out, or a paper jam occurred.	Load paper in the multi-purpose tray, replace the ink tank(s), or clear the paper jam.	p. 3-7 p. 11-2 p. 12-15
Fax Model TRY AGAIN IN B&W (#085)	You tried sending a color document to a machine that does not support color faxing.	Try sending again in black & white. Alternatively, enable the <COLOR DIRECT TX> setting.	p. 13-4
Fax Model TX nnnn SCANNING P. nnn MEMORY FULL PLEASE WAIT	The machine is sending a document and its memory is full.	The machine continues to send the document as memory becomes available.	
Fax Model TX/RX CANCELLED	You pressed [Stop/Reset] to cancel the transmission.	If required, try sending or receiving again.	
Fax Model TX/RX NO. nnnn	When the machine sends or receives a fax, it assigns it a unique identification number (nnnn).	Write the number down if you will need it later.	
WAIT COOLING	During printing, the printhead may have become too hot.	Allow the machine to cool down. The machine will resume printing when it has cooled down.	
WASTED INK NEAR FULL	The waste ink tank is nearly full.	If <CHECK PRINTER> appears, contact the Canon Customer Care Center.	
WRONG CARTRIDGE	The printhead is not installed correctly.	Try to reinstall the printhead. If the message remains in the LCD, the printhead may be defective. Contact the Canon Customer Care Center.	
Y INK EMPTY	The yellow ink tank in the printhead is empty.	Replace the ink tank.	p. 11-2

► If you cannot solve the problem

If you have a problem with your machine that you cannot solve with the information provided in this chapter, contact the Canon Customer Care Center.

⚠ CAUTION

- **If the machine makes strange noises, emits smoke or strange smells, unplug it immediately and contact the Canon Customer Care Center. Do not attempt to disassemble or repair the machine yourself.**

🚫 IMPORTANT

- **Attempting to repair the machine yourself may void the limited warranty.**

If you contact the Canon Customer Care Center, make sure you have the following information ready:

- Product name: MultiPASS MP730 or MultiPASS MP700
- Serial number (located on the label located at the back of the machine)
- Details of the problem
- Steps taken to try to resolve the problem and the results

Machine settings

▶ **Fax Model** ▶ Printing a list to check the current settings

Before changing any settings, you can print the USER'S DATA LIST to check the current settings of your machine. For details, see p. 10-5.

▶ Accessing the machine settings

Follow this procedure to change a setting:

- 1 Refer to the lists on the following pages to find the setting you want to change.
- 2 If there is a reference for the setting ①, refer to that page for details. If not, at the top of the list, note under which function key ② and menu ③ the setting is located.
- 3 Press [Copy], [Scan], [Photo Print], or **Fax Model** [Fax] depending under which function key ② the setting is located.
- 4 Press [Menu].
- 5 Use [◀] or [▶] to select the menu ③ under which the setting is located.
- 6 Press [Set].
 - You have now accessed the settings in the list.
- 7 Use [◀] or [▶] to select the setting you want.
- 8 Press [Set].
- 9 Follow these guidelines to scroll through and register settings:
 - Use [◀] or [▶] to scroll through settings.
 - To register a setting or access sub-settings, press [Set].
 - To return to a previous level, press [Menu].
- 10 When you have finished, press [Stop/Reset].

Example:

Name	Description	Setting	Ref.
1. 2 on 1	Copies two pages on one page (letter- or A4-size only).	—	—
2. BORDERLESS COPY	Copies without any borders (letter, 4" × 6", 5" × 7", or A4-size only).	—	p. 5-4
3. IMAGE REPEAT	Prints multiple copies of an image on a single sheet.	—	p. 5-6
AUTO	Automatically selects the number of repetitions.	—	—
MANUAL	Manually selects the number of repetitions.	—	—
VERTICAL	Selects the number of vertical repetitions.	1/2/3/4	—
HORIZONTAL	Selects the number of horizontal repetitions.	1/2/3/4	—
4. MIRROR IMAGE	Prints a mirror image of the original.	—	p. 5-8
5. ENTIRE IMAGE	Prints the original image to fit the selected print media size.	—	p. 5-9

▶ Settings

NOTE

- Default settings are shown in **bold** type.

Menu: SPECIAL COPY Function key: [Copy]

Name	Description	Setting	Details
1. 2 on 1	Copies two pages on one page (letter- or A4-size only).	—	p. 5-4
2. BORDERLESS COPY	Copies without any borders (letter-, 4" × 6"-, 5" × 7"-, or A4-size only).	—	p. 5-5
3. IMAGE REPEAT	Prints multiple copies of an image on a single sheet.	—	p. 5-6
AUTO	Automatically selects the number of repetitions.	—	
MANUAL	Manually selects the number of repetitions.		
VERTICAL	Selects the number of vertical repetitions.	1/2/3/4	
HORIZONTAL	Selects the number of horizontal repetitions.	1/2/3/4	
4. MIRROR IMAGE	Prints a mirror image of the original.	—	p. 5-8
5. ENTIRE IMAGE	Prints the original image to fit the selected print media size.	—	p. 5-9

Menu: MAINTENANCE Function keys: [Copy], [Scan], [Photo Print], Fax Model [Fax]

Name	Description	Setting	Details
1. NOZZLE CHECK	Prints the nozzle check pattern.	—	p. 11-4
2. HEAD CLEANING	Performs normal printhead cleaning.	—	p. 11-4
3. HEAD REFRESHING	Performs deep printhead cleaning.	—	p. 11-4
4. ALIGN PRINT HEAD	Aligns the printhead.	—	p. 11-5
HORIZ. PATTERN	Prints the horizontal pattern.	—	
CHANGE H VALUE	Selects the horizontal value for columns A to K on the printout.	A,B,C,D,E:-3to+7 F,G,H,I,J,K:-5to+5	
PRINT VERT. PATTERN?	Selects whether the vertical pattern is printed.	YES=(*) NO=(#)	
VERTICAL PATTERN	Prints the vertical pattern.		
CHANGE V VALUE	Selects the vertical value for columns L and M on the printout.	L, M: -3 to +3	
5. ROLLER CLEANING	Cleans the roller.	—	p. 11-9

Menu: USER DATA Function keys: [Copy], [Scan], [Photo Print], Fax Model [Fax]

Name	Description	Setting	Details
<small>Fax Model</small> 1. TEL REGISTRATION	—	—	
1. 1-TOUCH SPD DIAL	Registers one-touch speed dialing.	—	p. 7-2
2. CODED SPEED DIAL	Registers coded speed dialing.	—	p. 7-4
3. GROUP DIAL	Registers group dialing.	—	p. 7-6
<small>Fax Model</small> 2. FAX SETTINGS	—	—	
1. USER SETTINGS	—	—	
1. DATE & TIME	Sets the current date and time.	—	p. 6-3
2. DATE SETUP	Selects the date format displayed in the LCD and printed on faxes you send.	MM/DD/YYYY DD/MM YYYY YYYY MM/DD	
3. UNIT TELEPHONE #	Enters the fax/telephone number printed on faxes you send.	—	p. 6-3
4. UNIT NAME	Enters the name printed on faxes you send.	—	p. 6-3
5. TX TERMINAL ID	—	—	
1. TTI POSITION	Selects the position of the sender information (outside or inside the image area) when sending black & white faxes. (Automatically set inside the image area for color faxes.)	OUTSIDE IMAGE INSIDE IMAGE	
2. TELEPHONE # MARK	Selects the mark to appear before the fax/telephone number printed on faxes you send.	FAX TEL	
6. OFFHOOK ALARM	Enables/disables the alarm that alerts you if the handset is not hung up properly.	ON OFF	
7. VOLUME CONTROL	—	—	
1. CALLING VOLUME	When the machine is set to ring, selects the ring volume.	1/2/3	
2. LINE MONITOR VOL	Selects the dialing and on-hook volume.	0 (off)/1/2/3	
8. RX CALL LEVEL	Selects the ring type for incoming calls.	HIGH STANDARD	
9. TEL LINE TYPE	Selects the telephone line type setting for your machine.	TOUCH TONE ROTARY PULSE	p. 6-4
2. REPORT SETTINGS	—	—	
1. TX REPORT	Enables/disables automatic printing of a transmission report after sending.	PRINT ERROR ONLY OUTPUT YES OUTPUT NO	p. 10-3
PRINT WITH IMAGE	If you select <PRINT ERROR ONLY> or <OUTPUT YES>, selects whether the first page of the fax is printed under the report (black & white faxes only).	ON OFF	
2. RX REPORT	Enables/disables automatic printing of a reception report after receiving.	OUTPUT NO PRINT ERROR ONLY OUTPUT YES	p. 10-4

Name	Description	Setting	Details
3. ACTIVITY REPORT	Enables/disables automatic printing of an ACTIVITY REPORT after every 20 transactions.	AUTO PRINT ON AUTO PRINT OFF	p. 10-2
3. TX SETTINGS	—	—	
1. ECM TX*	Enables/disables Error Correction Mode (ECM) during sending.	ON OFF	
2. MID PAUSE SET	Selects the pause length when you press [Redial/Pause].	2 SEC (1 to 15)	
3. AUTO REDIAL	Enables/disables automatic redialing.	ON OFF	p. 8-5
1. REDIAL TIMES	If you select <ON>, selects the number of redialings.	2 TIMES (1 to 10)	
2. REDIAL INTERVAL	If you select <ON>, selects the length of time between redialings.	2 MIN. (2 to 99)	
4. TIME OUT	Enables/disables automatic scanning without having to press [Start] after using speed dialing or redialing to send a document.	ON OFF	
5. TX START SPEED	Selects the speed at which the machine starts transmitting.	33600bps 14400bps 9600bps 7200bps 4800bps 2400bps	
6. COLOR DIRECT TX	Enables/disables sending of color documents to fax machines that do not have color faxing capability.	OFF ON	
4. RX SETTINGS	—	—	
1. ECM RX*	Enables/disables Error Correction Mode (ECM) during reception.	ON OFF	
2. FAX/TEL AUTO SW	If you select <FAX/TEL AUTO SW> as the receive mode, customizes its settings.	—	p. 9-2
1. RING START TIME	Selects the time the machine takes to check whether a call is a fax or voice call.	8 SEC (0 to 30)	
2. F/T RING TIME	Selects the ring length for voice calls.	15 SEC (10 to 45)	
3. DEFAULT ACTION	Selects whether the machine switches to receive mode after the ring time has elapsed, or whether it disconnects the call.	RECEIVE DISCONNECT	
3. DRPD:SELECT FAX	If you select <DRPD> as the receive mode, select the ring pattern for the machine.	DOUBLE RING SHORT-SHORT-LONG SHORT-LONG-SHORT OTHER RING TYPE NORMAL RING	p. 9-4

* ECM stands for Error Correction Mode. Resends image data that was lost due to phone line interference so thereby making sent and received images seamless.

Name	Description	Setting	Details
4. INCOMING RING	If you select <FAX/TEL AUTO SW>, <DRPD>, or <FAX ONLY MODE> as the receive mode, enables/disables ringing for fax calls. (A telephone must be connected to your machine for ringing to occur.)	OFF ON	
RING COUNT	If you select <ON>, selects the number of rings for fax calls.	2 TIMES (1 to 99)	
5. MAN/AUTO SWITCH	If you select <MANUAL MODE> as the receive mode, selects if the machine switches to fax receive mode after ringing for a specified length of time.	OFF ON	
F/T RING TIME	If you select <ON>, selects the length of time the machine rings before switching to fax receive mode.	15 SEC (5 to 99)	
6. REMOTE RX	Enables/disables remote receiving.	ON OFF	
REMOTE RX ID	If you select <ON>, selects the remote receiving ID.	25 (00 to 99)	
7. RX REDUCTION	Enables/disables automatic reduction of faxes to fit the paper loaded.	ON OFF	
REDUCE DIMENSION	Selects the direction of the reduction.	VERTICAL ONLY HORIZ & VERTICAL	
8. RX START SPEED	Selects the speed at which the RX machine starts receiving.	3360bps 14400bps 9600bps 7200bps 4800bps 2400bps	
3. PRINTER SETTINGS	—	—	
1. QUIET MODE	Enables/disables quiet printing mode.	OFF ON	
2. EXTENSION AMOUNT	For borderless printing or copying, selects the width cropped from the borders of the original image.	SMALL LARGE	
4. SYSTEM SETTINGS	—		
1. Fax Model AUDIBLE TONES			
1. KEYPAD VOLUME	Selects the beep volume when pressing keys on the operation panel.	0 (off)/1/2/3	
2. ALARM VOLUME	Selects the alarm volume.	0 (off)/1/2/3	
2. CARD PROTECT	Enables/disables overwriting memory card data in all modes except photo print mode.	ON OFF	p. 4-15
3. DISPLAY LANGUAGE	Selects the language for LCD messages and reports.	ENGLISH FRENCH SPANISH PORTUGUESE	
4. Fax Model DAYLIGHT SAV TIME	Enables/disables daylight saving. If you select <ON>, you can select additional sub-settings.	ON OFF	p. 6-5

Fax Model **Menu: RECEIVE MODE** **Function key: [Fax]**

Name	Description	Setting	Details
FAX/TEL AUTO SW	Selects <FAX/TEL AUTO SW> receive mode.	—	p. 9-2
FAX ONLY MODE	Selects <FAX ONLY MODE> receive mode.	—	p. 9-3
DRPD	Selects <DRPD> receive mode.	—	p. 9-4
MANUAL MODE	Selects <MANUAL MODE> receive mode.	—	p. 9-5
ANS.MACHINE MODE	Selects <ANS.MACHINE MODE> receive mode.	—	p. 9-6

Fax Model **Menu: MEMORY REFERENCE** **Function key: [Fax]**

These settings can only be accessed when there is a document in memory.

Name	Description	Setting	Details
1. DOC. MEMORY LIST	Prints the DOC. MEMORY LIST.	—	p. 8-8
2. PRINT DOCUMENT	Prints a document in memory.	—	p. 8-8
3. DELETE DOCUMENT	Deletes a document in memory.	—	p. 8-8

Fax Model **Menu: REPORTS/LISTS** **Function key: [Fax]**

Name	Description	Setting	Details
1. ACTIVITY REPORT	Prints an ACTIVITY REPORT.	—	p. 10-2
2. SPEED DIAL LIST	—	—	
1. 1-TOUCH LIST	Prints the 1-TOUCH SPD DIAL LIST.	—	p. 7-9
SORTED OUTPUT	Selects the order of the destinations in the list. <YES=(*)>: Prints the list in alphabetical order. <NO=(#)>: Prints the list in key order.	YES=(*) NO=(#)	
2. CODED DIAL LIST	Prints the CODED SPEED DIAL LIST.	—	p. 7-9
SORTED OUTPUT	Selects the order of the destinations in the list. <YES=(*)>: Prints the list in alphabetical order. <NO=(#)>: Prints the list in key order.	YES=(*) NO=(#)	
3. GROUP DIAL LIST	Prints the GROUP DIAL LIST.	—	p. 7-9
3. USER DATA LIST	Prints the USER DATA LIST.	—	p. 10-5
4. DOC. MEMORY LIST	Prints the DOC. MEMORY LIST.	—	p. 8-8

Menu: PHOTO PRINT MODE Function key: [Photo Print]

Name	Description	Setting	Details
1. PHOTO PRINT MODE		—	
INDEX	—		p. 4-5
SELECT PAPER SIZE	Selects the print media size for the index.	LTR 4" × 6" 5" × 7" A4	
SELECT PAPER TYPE	Selects the print media type for the index.	PHOTO PAPER PRO PLAIN PAPER	
ALL FRAMES	—	—	p. 4-6
SELECT PAPER SIZE	Selects the print media size for the photographs.	LTR 4" × 6" 5" × 7" A4	
SELECT PAPER TYPE	Selects the print media type for the photographs.	PHOTO PAPER PRO PLAIN PAPER	
BORDERLESS PRINT	If you select <PHOTO PAPER PRO>, enables/disables borderless printing for the photographs.	OFF ON	
SINGLE FRAME	—	—	p. 4-8
FILE NO:	Selects the file number.	0001 to 9999	
NUMBER OF PRINTS	Selects the number of copies.	1 to 99 COPIES	
SELECT PAPER SIZE	Selects the print media size for the photograph.	LTR 4" × 6" 5" × 7" A4	
SELECT PAPER TYPE	Selects the print media type for the photograph.	PHOTO PAPER PRO PLAIN PAPER	
BORDERLESS PRINT	If you select <PHOTO PAPER PRO>, enables/disables borderless printing for the photograph.	OFF ON	
FRAME RANGE	—	—	p. 4-10
FIRST FILE:	Selects the first photograph number.	0001 to 9999	
LAST FILE:	Selects the last photograph number.	0001 to 9999	
SELECT PAPER SIZE	Selects the print media size for the photographs.	LTR 4" × 6" 5" × 7" A4	
SELECT PAPER TYPE	Selects the print media type for the photograph.	PHOTO PAPER PRO PLAIN PAPER	
BORDERLESS PRINT	If you select <PHOTO PAPER PRO>, enables/disables borderless printing for the photographs.	OFF ON	

Name	Description	Setting	Details
DPOF	—	—	p. 4-12
SELECT PAPER SIZE	Selects the print media size for the photographs.	LTR 4" × 6" 5" × 7" A4	
SELECT PAPER TYPE	Selects the print media type for the photographs.	PHOTOPAPERPRO PLAIN PAPER	
BORDERLESS PRINT	If you select <PHOTO PAPER PRO>, enables/disables borderless printing for the photographs.	OFF ON	
2. VIVID PHOTO PRINT	Enables/disables to make colors, especially blues and greens, appear more vibrant.	OFF ON	p. 4-14
3. PRINT PHOTO DATE	Enables/disables date printing.	OFF ON	p. 4-14

► General specifications

Power source	120 V/60 Hz
Power consumption	<ul style="list-style-type: none"> • Maximum: Approx. 39.1 W Fax Model Approx. 51.5 W • Standby: Approx. 8.0 W Fax Model Approx. 10.4 W
Weight (Components attached)	24 lb./10.9 kg
Dimensions	Fax Model 28.2 lb./12.8 kg

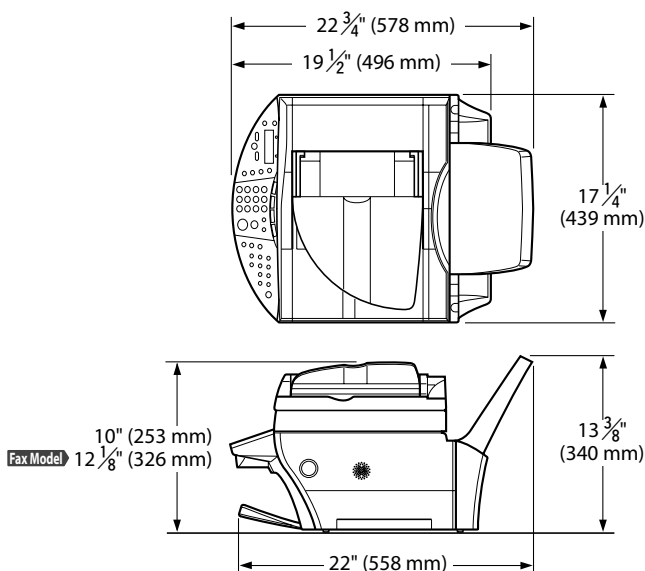

Environmental conditions	<ul style="list-style-type: none"> • Temperature: 59°–81.5°F (15°–27.5°C) • Humidity: 20%–80%
Liquid Crystal Display (LCD)	20 × 2
Display languages	English/French/Spanish/Portuguese
Applicable standards	<ul style="list-style-type: none"> • Electrical safety: UL 1950, C-UL • Radiation: FCC Part 15 Class B, IC, Class B • Fax Model PTT: FCC part 68, IC CS-03 • Other: Energy Star Compliant, FCC sec.255
Fax Model ADF capacity	→ p. 2-1
Multi-purpose tray capacity	→ p. 3-1

Printable areas

Note on printing area illustrations:

Printing area: Canon recommends that you print within this area.

Printable area: The area where it is possible to print. However, printing in this area can adversely affect print quality or paper feed precision.

• Paper printable areas:

Letter size: $8 \times 10 \frac{3}{4}$ in. (203.2 \times 271.4 mm)

Legal size: $8 \times 13 \frac{3}{4}$ in. (203.2 \times 347.6 mm)

4" \times 6" size: $3 \frac{3}{4} \times 5 \frac{3}{4}$ in. (94.8 \times 144.4 mm)

5" \times 7" size: $4 \frac{3}{4} \times 6 \frac{3}{4}$ in. (120.2 \times 169.8 mm)

A4 size: $8 \times 11 \frac{3}{8}$ in. (203.2 \times 289 mm)

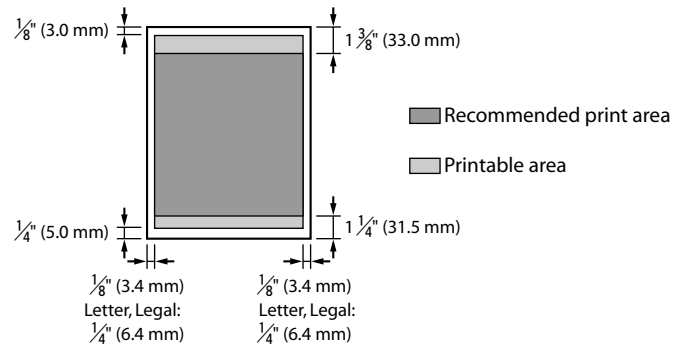

NOTE

- Borderless printing allows you to make prints with no margins. However, it may cause the top and bottom paper edges to decrease in print quality or become soiled.

• Envelope printable areas:

US COM #10: $8 \frac{3}{8} \times 3 \frac{7}{8}$ in. (211.8 \times 98 mm)

European DL: $7 \frac{1}{2} \times 4 \frac{1}{8}$ in. (190.5 \times 103.2 mm)

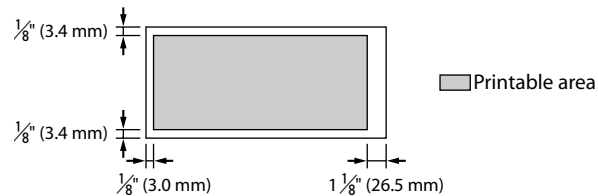

• **Banner paper printable areas:**

Letter size: $8 \times 65 \frac{3}{4}$ in. (203.2 \times 1668.4 mm)

A4 size: $8 \times 69 \frac{7}{8}$ in. (203.2 \times 1774 mm)

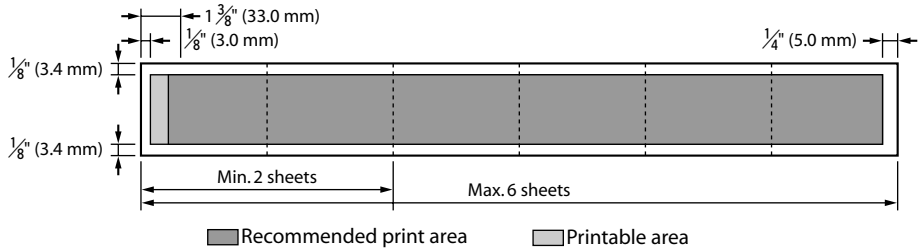

Scanned area

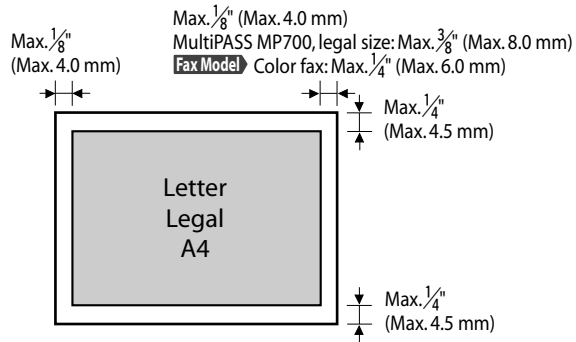

NOTE

- For entire image copying, the entire area of the document is scanned.

► Ink specifications

Ink tank colors/capacity

- Black (BCI-3eBK): approx. 740*, approx. 1500**
- Cyan (BCI-3eC): approx. 570**
- Magenta (BCI-3eM): approx. 440**
- Yellow (BCI-3eY): approx. 380**

* 1500 characters per page, normal text, at standard and plain paper mode with XP printer driver.

** Based on printing the ISO JIS-SCID No. 5 pattern at standard and plain paper mode with XP printer driver.

► Print specifications

Printing method	Bubble jet on-demand
Paper handling	Automatic feed
Print media size and weight	→ p. 3-1
Recommended print media	→ p. 3-1
Print speed	<ul style="list-style-type: none">• Black printing: Fast: 22 pages/minute Standard: 13.0 pages/minute• Color printing: Fast: 14 pages/minute Standard: 9.0 pages/minute (Based on Canon standard pattern)
Print width	<ul style="list-style-type: none">• Max. 8 in. (203.2 mm)• Borderless printing: 8½ in. (216.0 mm)
Printing resolution	Max. 4800 (horizontal) × 1200 (vertical) dpi

► Photo print specifications

Interface	Card slot
Memory card	<ul style="list-style-type: none">• Compact flash (Except Microdrive)—Type I, II• Smart media• Memory stick• SD memory card• Multimedia card
Print media	<ul style="list-style-type: none">• Plain paper• Photo Paper Pro PR-101/PC-101S• Photo Paper Plus Glossy PP-101• Matte Photo Paper MP-101
Layout	<ul style="list-style-type: none">• Photo Paper Pro: Letter/A4: With/without borders, index (max. 70 frames) Card: With borders, index (max. 15 frames)• Plain paper: Letter/A4: With/without borders, index (max. 70 frames)
Features	<ul style="list-style-type: none">• Date printing• Vivid photo printing• DPOF function-compatible (Index printing, specified quantity, specified frames, date printing, image number printing)

► Copy specifications

Copy speed	<ul style="list-style-type: none">• Black & white: <B&W DRAFT> Approx. 22 pages/minute (letter size)• Color: <COLOR FAST> Approx. 14 pages/minute (letter size) (Based on BJ printer specific speed test pattern.)
No. of copies	Maximum 99 copies
Density adjustment	9 levels
Zoom	25%–400%

Fax Model Fax specifications

Applicable line	Public Switched Telephone Network (PSTN)
Compatibility	G3
Data compressing system	MH, MR, MMR, JBIG, JPEG
Modem type	Fax modem
Modem speed	33600/14400/9600/7200/4800/2400 bps Automatic fallback
Transmission speed	<ul style="list-style-type: none">• Black & white: Approx. 3 seconds/page at 33.6 Kbps, ECM-MMR, transmitting from memory (Based on ITU-T No.1 Chart, standard mode.)• Color: Approx. 1 minute/page at 33.6 Kbps, ECM-JPEG, transmitting from memory (Based on Canon COLOR FAX TEST SHEET.)
Scanning image processing	<ul style="list-style-type: none">• UHQ™ (Ultra High Quality) image enhancement• Halftones: 64 levels of gray• Density adjustment: 3 levels
Memory	Transmission/reception: 250 pages (Based on ITU-T No.1 Chart, standard mode.)
Fax scanning speed	Approx. 5.3 seconds/page (Based on ITU-T No.1 Chart, standard mode.)
Fax resolution	<ul style="list-style-type: none">• <B&W STANDARD>: 203 pels/in. × 98 lines/in. (8 pels/mm × 3.85 lines/mm)• <B&W FINE>, <B&W PHOTO>: 203 pels/in. × 196 lines/in. (8 pels/mm × 7.70 lines/mm)• <COLOR STANDARD>, <COLOR FINE>: 200 × 200 dpi
Dialing	<ul style="list-style-type: none">• Automatic dialing<ul style="list-style-type: none">One-touch speed dialing (10 destinations)Coded speed dialing (100 destinations)Group dialing (Max. 109 destinations)• Regular dialing (with numeric keys)• Automatic redialing• Manual redialing (with [Redial/Pause] key)
Networking	<ul style="list-style-type: none">• Sequential broadcast (Max. 111 destinations)• Automatic reception• Automatic fax/tel switchover• DRPD (Distinctive Ring Pattern Detection)• Remote reception by telephone (Default ID: 25)• Non-ring reception• ECM deactivation• ACTIVITY REPORT (after every 20 transactions)• Non-delivery report• TTI (Transmit Terminal Identification)

▶ Telephone specifications

Connection

Telephone/answering machine (CNG detecting signal)/data modem

Specifications subject to change without notice.

Index

- ◀ (-) key 1-4
- ▶ (+) key 1-4
- 1-TOUCH SPD DIAL LIST 7-9, 10-1
- 2 on 1 copying 5-4
- ACTIVITY REPORT 10-1, 10-2
- ADF 1-3
 - cleaning 11-8, 11-9
 - loading documents in 2-2
 - requirements for loading in 2-1
- Alarm light 1-4
- Aligning printhead 11-5, 11-6
- All frames printing 4-6, 4-7
- ANS. MACHINE MODE receive mode 9-6
- Answering machine, receiving with 9-6
- AUTO REDIAL message 12-19
- Automatic
 - Document Feeder. *See* ADF
 - redialing 8-5
- B&W key 1-5
- Banner Paper BP-101
 - loading 3-9
- Bk INK EMPTY message 12-19
- Black & white
 - copying 5-1
 - sending 8-3
- Borderless copying 5-5, 5-6
- BUSY/NO SIGNAL message 12-19
- C INK EMPTY message 12-19
- Canceling
 - manual sending 8-2
 - memory sending 8-1
 - receiving 9-6
- CANNOT USE THIS CARD message 12-19
- CARD READER BUSY message 12-19
- Card slot 1-3
- CARTRIDGE JAMMED message 12-19
- CD-ROM 1-2
- CHANGE PAPERSIZE FAX:message 12-19
- Characters, entering 6-1
- CHECK DOCUMENT message 12-20
- CHECK PAPER SIZE message 12-20
- CHECK PRINTER message 12-20
- Cleaning
 - ADF 11-8, 11-9
 - exterior 11-7
 - inside machine 11-7, 11-8
 - interior 11-7 to 11-9
 - printhead 11-4
 - roller 11-9
 - scanning area 11-7
- CLEAR PAPER JAM message 12-20
- Coded Dial key 1-5
- CODED SPEED DIAL LIST 7-9, 10-1
- Coded speed dialing
 - changing entry 7-5
 - deleting entry 7-5
 - list 7-9
 - registering 7-4
 - using 7-8
- Color
 - copying 5-1
 - key 1-5
 - sending 8-3
- Components 1-2 to 1-5
- Computer
 - problems printing from 12-2 to 12-5
 - problems turning on 12-2
- Copy key 1-4
- Copying 5-1
 - adjusting exposure 5-2
 - adjusting image quality 5-2
 - advanced features 5-4 to 5-9
 - borderless 5-5
 - document requirements 2-1
 - enlarge 5-3
 - in black & white 5-1
 - in color 5-1
 - mirror 5-8
 - problems 12-12
 - reduce 5-3, 5-9
 - repeating image 5-6, 5-7
 - two pages on one 5-4
- COVER OPEN message 12-20
- DATA IN MEMORY/CANNOT TURN OFF message 12-20
- Date
 - entering 6-3
 - printing 4-14
- Daylight saving, setting 6-5 to 6-6
- Density. *See* Contrast

Destination labels 1-2
 Dialing
 methods 8-4
 through switchboard 8-10
 DOC. MEMORY LIST 8-8, 10-1
 DOC. TOO LONG message 12-20
 Document
 cover 1-3
 guides 1-3
 loading 2-2
 output slot 1-3
 problems 2-1
 removing jams 12-16, 12-17
 requirements 2-1
 tray 1-2, 1-3
 Documentation 1-2
 DPOF printing 4-12, 4-13
 DRPD receive mode 9-4
 ECM RX message 12-20
 ECM TX message 12-20
 Enlarge copying 5-3
 Enlarge/Reduce key 1-4
 Envelopes 3-1
 loading 3-7, 3-8
 Exposure
 adjusting for copying 5-2
 adjusting for sending 8-4
 key 1-4
 Fax
 key 1-4
 Resolution. *See* Image quality
 FAX ONLY MODE receive mode 9-3
 FAX/TEL AUTO SW receive mode 9-2
 Features 1-1, 1-2
 Feeder cover 1-3
 FILE NOT READABLE 12-20
 Frame range printing 4-10 to 4-11
 Glossy Photo Paper GP-301/GP-301N 3-2
 GROUP DIAL LIST 7-9, 10-1
 Group dialing
 changing entry 7-7
 deleting entry 7-7
 list 7-9
 registering 7-6, 7-7
 using 7-8
 High
 Resolution Paper HR-101N 3-2
 Hook key 1-5
 Image quality
 adjusting for copying 5-2
 adjusting for sending 8-3
 Image Quality key 1-4
 In Use/Memory light 1-4
 Index printing 4-5
 Indicator light 1-3
 Ink tank 1-2
 guidelines 11-1
 replacing 11-2
 when to replace 11-1
 INSERT PHOTO CARD message 12-21
 INVALID KEY/SETTING message 12-21
 Jams
 removing document 12-16, 12-17
 removing paper 12-15, 12-16
 LCD 1-4
 if nothing displays 12-14
 messages 12-19 to 12-22
 Letters, entering 6-1
 Lists 10-1
 LOAD PAPER (PRESS START KEY) message 12-21
 M INK EMPTY message 12-21
 Machine 1-2
 MACHINE IN USE/CANNOT TURN OFF message 12-21
 MAINTENANCE menu 13-2
 Manual
 receiving 9-2
 redialing 8-5
 sending 8-2
 MANUAL receive mode 9-1
 Matte Photo Paper MP-101 3-2
 Memory
 deleting document in 8-8, 8-9
 printing document in 8-8, 8-9
 printing list of documents in 8-8
 sending 8-1
 Memory card
 compatible 4-1
 inserting 4-2
 problems using 12-12, 12-13
 removing 4-2
 MEMORY CLEAR REPORT 10-1
 MEMORY FULL message 12-21
 MEMORY REFERENCE menu 13-6
 MEMORY USED nn % message 12-21
 Menu key 1-4
 Menus 13-2 to 13-8. *See also individual menu names*
 Messages 12-19 to 12-22. *See also individual menu names*
 LCD 12-19 to 12-22
 Mirror copying 5-8
 MULTI TX/RX REPORT 10-1
 Multi-purpose tray 1-2, 1-3
 NO FILES ON CARD message 12-21
 NO RX PAPER message 12-21

- NO TEL # message 12-21
- NOT AVAILABLE message 12-22
- Nozzle check pattern, printing 11-4
- Numbers, entering 6-1
- Numeric keys 1-5
- ON/OFF (1 sec.) key 1-5
- One-touch speed dialing
 - changing entry 7-3
 - deleting entry 7-3
 - keys 1-5
 - list 7-9
 - registering 7-2
 - using 7-8
- Open button 1-3
- Operation panel 1-3 to 1-5
- Paper
 - loading 3-7
 - removing jams 12-15, 12-16
 - Select key 1-4
- Paper output tray 1-2, 1-3
 - removing jams in 12-15
- Paper thickness lever 1-3
 - setting 3-5
- Photo
 - Paper Plus Glossy PP-101 3-2
 - Paper Pro PC-101S 3-3
 - Paper Pro PR-101 3-3
- Photo Print key 1-5
- PHOTO PRINT MODE menu 13-7
- Photo printing
 - all frames 4-6, 4-7
 - date printing 4-14
 - DPOF 4-12, 4-13
 - frame range 4-10, 4-11
 - index 4-5, 4-6
 - methods 4-4
 - problems 12-12, 12-13
 - single frame 4-8, 4-9
 - vivid 4-14
- Plain paper 3-1
- Platen glass 1-3
 - loading documents on 2-2
 - requirements for loading on 2-1
- Power
 - cord 1-2
 - problems 12-14
- Print media
 - for photo printing 4-1
 - guidelines 3-4
 - loading 3-7 to 3-9
 - recommended 3-1 to 3-4
 - setting size 3-6
 - setting type 3-6
- Printer cover 1-3
- Printhead 1-2
 - aligning 11-5, 11-6
 - cleaning 11-4, 11-7
 - holder 1-3
 - maintaining 11-3
- Printing
 - problems 12-2 to 12-5
- PROBLEM READING CARD message 12-22
- Problems
 - cannot solve 12-23
 - copying 12-12
 - documents 2-1
 - installing software 12-1
 - power 12-14
 - printing from computer 12-2 to 12-5
 - receiving faxes 12-9, 12-10
 - removing software 12-1
 - scanning 12-6, 12-9
 - sending 12-11, 12-12
 - telephone 12-12
 - turning on computer 12-2
 - using memory card 12-12, 12-13
- PUT IN CARTRIDGE message 12-22
- REC'D IN MEMORY message 12-22
- RECEIVE MODE menu 13-6
- Receive mode, setting 9-1
- Receiving
 - canceling 9-6
 - DRPD 9-4
 - faxes and voice calls automatically 9-2, 9-3
 - faxes only 9-3
 - manually 9-5
 - with answering machine connected 9-6
- Receiving to machine problems 12-12
- Redial/Pause key 1-5
- Redialing 8-5, 8-6
- Reduce copying 5-3, 5-9
- Repeat copying 5-6, 5-7
- Replacing ink tanks 11-2
- Reports 10-1
- REPORTS/LISTS menu 13-6
- Resolution. *See* Image quality
- Resume key 1-4
- Roller, cleaning 11-9
- RX REPORT 10-1, 10-4
- Scan
 - exposure. *See* Exposure 8-4
 - key 1-5
- Scanning
 - document requirements 2-1

- problems 12-6, 12-9
- Scanning unit 1-3
- Sender information 6-2
- Sending
 - adjusting exposure 8-4
 - adjusting image quality 8-3
 - document requirements 2-1
 - in black & white 8-3
 - in color 8-3
 - manual 8-2
 - memory 8-1
 - methods 8-1, 8-2
 - multiple recipients 8-7
 - sequential broadcasting 8-7
- Sending from computer problems 12-11, 12-12
- Sending from machine problems 12-11, 12-12
- Sequential broadcasting 8-7
- Set key 1-4
- Settings 13-2 to 13-8
 - accessing 13-1
- Single frame printing 4-8 to 4-9
- Software
 - problems installing 12-1
 - problems removing 12-1
- SPECIAL COPY menu 13-2
- Speed dialing
 - lists 7-9
 - methods 7-1
 - registering 7-2, 7-3
 - using 7-8
- Start key 1-5
- Stop/Reset key 1-5
- Switchboard, dialing through 8-10
- Symbols, entering 6-1
- Telephone line
 - cord 1-2
 - type 6-4
- Telephone problems 12-12
- Time entering 6-3
- Tone
 - dialing, switching temporarily to 8-10
- Tone key 1-5
- Transparencies CF-102 3-3
- Tray cover 1-2, 1-3
- TRY AGAIN IN B&W message 12-22
- T-Shirt Transfers TR-201 3-4
- TX nnnn/SCANNING P.nnn/MEMORY FULL/PLEASE
WAIT message 12-22
- TX REPORT 10-1
- TX/RX CANCELLED message 12-22
- TX/RX NO.nnnn message 12-22
- USER DATA menu 13-3 to 13-5
- USER'S DATA LIST 10-1, 10-5
- VIVID PHOTO PRINT menu 13-8
- Vivid photo printing 4-14
- WAIT COOLING message 12-22
- WASTED INK NEAR FULL message 12-22
- WRONG CARTRIDGE message 12-22
- Y INK EMPTY message 12-22